

Anatomy of Seiko #0 shutter used on Zenzanon lenses

By M.Vettore (V.1.3)

Seiko shutter #0 could be analyzed in two views: functional and physical. In the functional view it consists of two subsystems:

- A subsystem controls all happens before shooting phase.
- A subsystem controls all happens in the shooting phase.

The two subsystems are strongly coupled by the disk marked **A** on the picture PIC 1 and weakly coupled by the disks marked **M** and **N** on picture PIC 11.

In the physical view Seiko shutter #0 is like a sandwich, 2 slices with filler.

- The bottom slice is the rear side of the shutter, faced to the lens back.
The rear side contains the mechanical interface between the camera body and the shutter, indeed through the lens. This side controls the cocking and shooting actions and the DOF preview command although the command lever is on the other side of the lens.
- The upper slice is the front side of the shutter faced to the lens front; it is associated with the lens controls, like aperture (diaphragm) ring and A/T lever.
- The filler is the shutter body; it consists of two sections, one with the shutter and diaphragm blades, and the other with the mechanisms to control the first.

Rear side

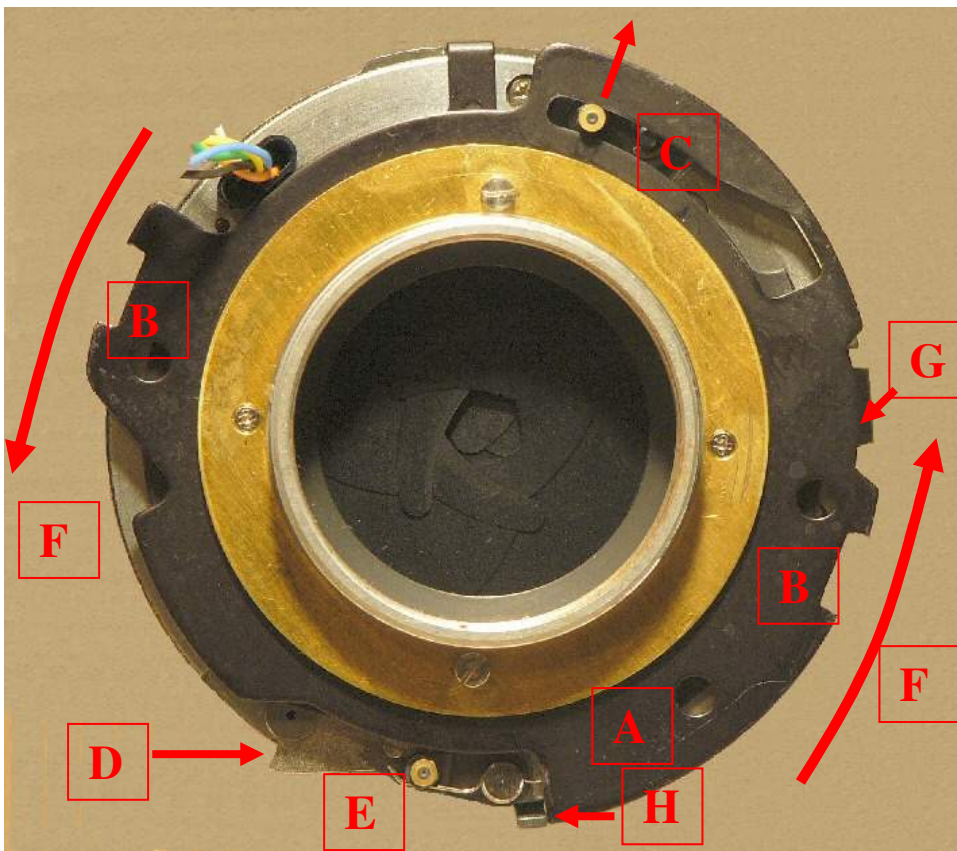

PIC 1: Rear view of Seiko #0 shutter (old style) uncocked

A	Slotted disk
B	Slots for the lever arms driven by the pins in the back of lens
C	Shutter drive roller, this roller is spring loaded, the arrow shows the direction the spring heads
D	DOF preview lever, the arrow shows the pushing direction to close the diaphragm
E	Diaphragm drive roller
F	Cocking direction of the lever arms
G	Lever drives shutter mechanism
H	Lever drives shutter trigger

Table 1

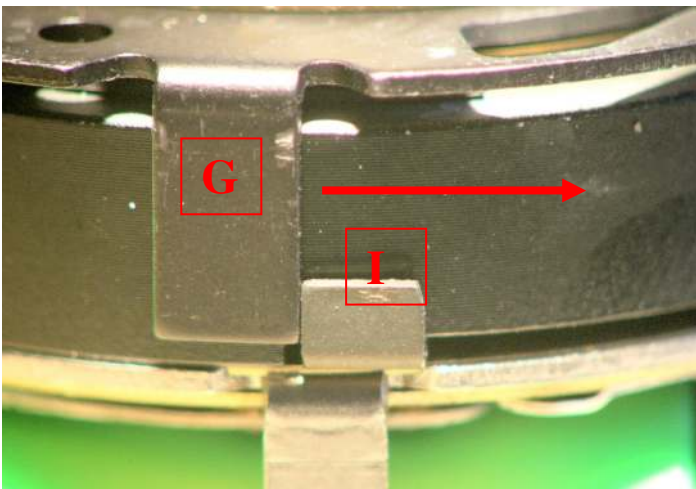

PIC 2: Side view, the lever **G** and the lever **I** load the shutter mechanism. Shutter is uncocked. The arrows shows the direction of lever **G** and **I** when shutter cocks.

The lever, after the cocking phase, remains at the end of its span because an escapement inside the shutter

In the next photo the lever **G** has been retracted but lever **I** remains loaded.

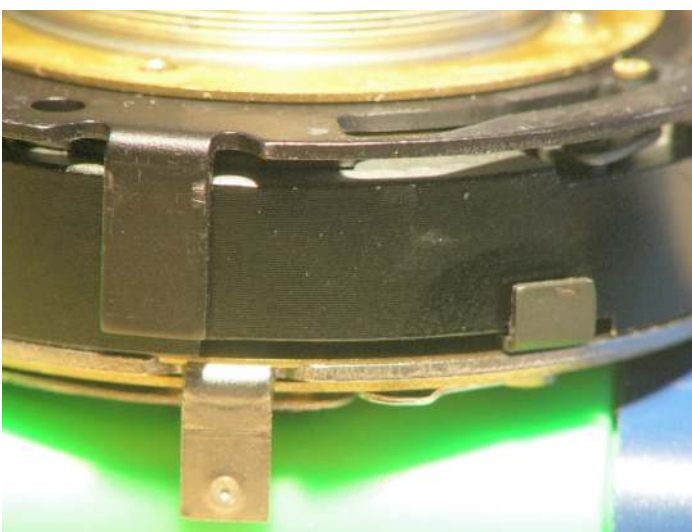

PIC 3: The shutter is ready to fire.

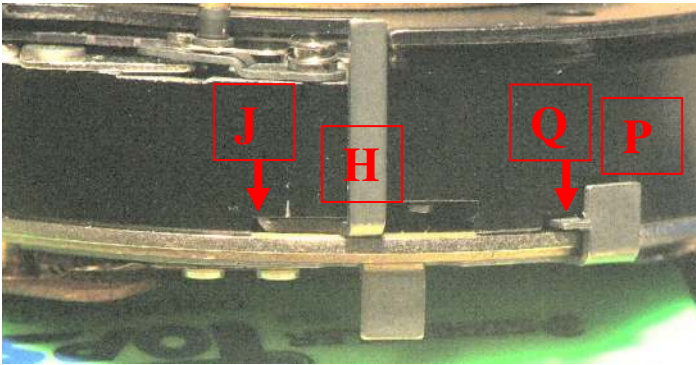

PIC 4: Side view. The lever **H**, this lever driven by the cam cut on the disk **A** is the shutter trigger. Lever **H** must hit lever **J** to fire the shutter. **Q** is the A/T selector latch; **P** is the A/T selector extending lever.

Sequence of operations

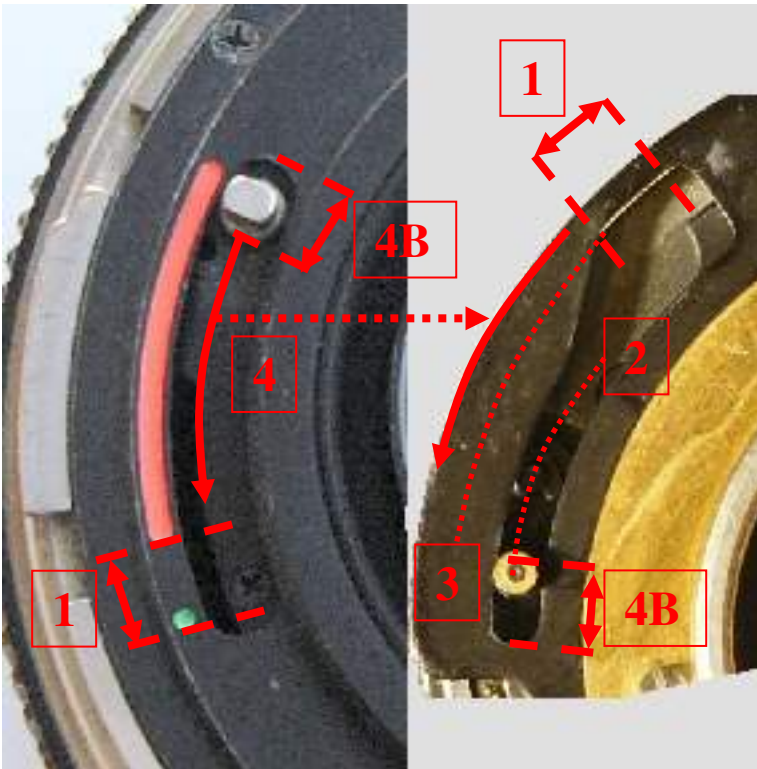

PIC 5: Lens pins drive shutter roller (uncocked).

1	Shutter cocking engagement area
2	When shutter roller lies on this orbit the shutter is full close
3	When shutter roller lies on this orbit the shutter is full open
4	Rotating the pin counterclockwise/clockwise also rotates the disk
4B	A little gap exists into pin movement, the pins don't rest at the very beginning of their slots

Table 2

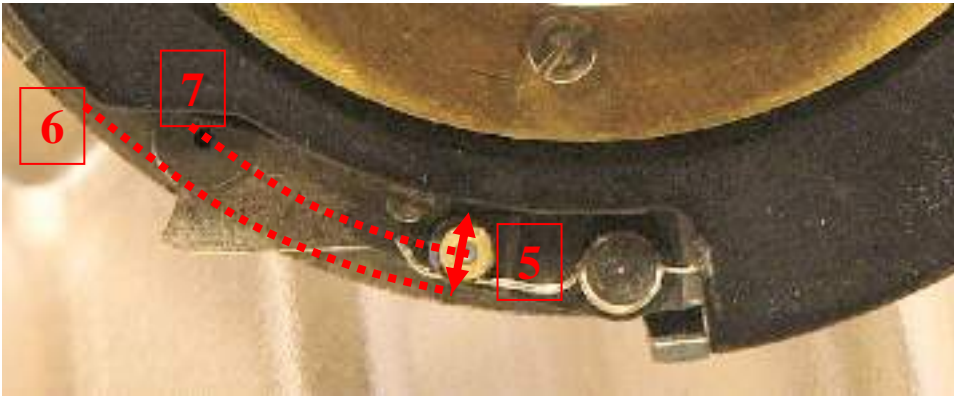

PIC 6: Diaphragm pin (lens uncocked)

5	Diaphragm roller spans from the higher to the lower F setting
6	Diaphragm roller orbit at lower F setting (full open)
7	Diaphragm roller orbit at choused F setting

Table 3

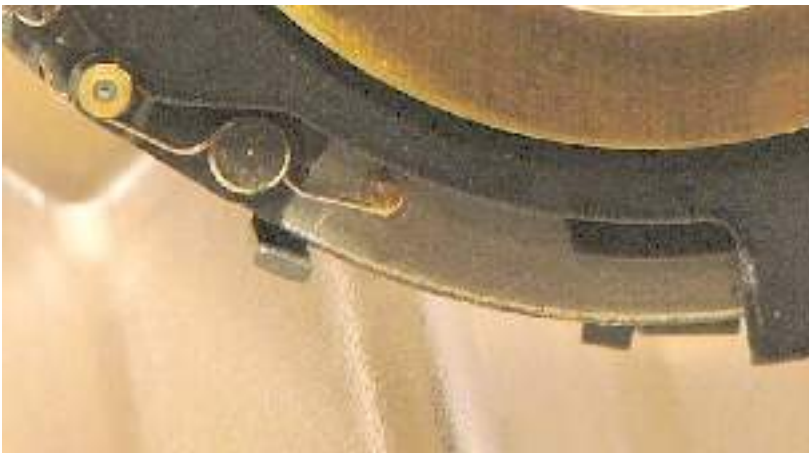

PIC 7: Diaphragm roller (lens cocked)

Cocking

1. To cock the shutter the lens pins are rotated counterclockwise (#4 on PIC 5), the pins move two arms inside the lens (see PIC 12 on [this page](#)) the arms are engaged through the slots **B** (PIC 1) on the disk **A** (PIC 1) and rotate the disk.
2. The disk rotating pushes the lever **G** (PIC 2) against lever **I** (PIC 2) loading shutter springs, somewhere in the cocking shutter engagement area; an escapement inside the shutter lock the lever **I** (PIC 2), see PIC 3.
3. During the disk rotation the shutter roller is released from orbit **2** (PIC 5) to orbit **3** (PIC 5) or from full shutter close to full shutter open.
4. At the same time the diaphragm roller is moved from the preset position determined by the aperture ring (orbit **7** on PIC 6) to full open position (orbit **6** in PIC 6) of course it is still possible to momentary move the diaphragm aperture back to preset position using the DOF preview lever (**D** on PIC 1).

Shooting

1. When camera shoots the lens pins are rotated clockwise till the end of their slots overcoming the gap **4B** (PIC 5) this causes the rotation of the slotted disk.
2. Shutter roller returns back to uncocked position full closing the shutter, diaphragm roller also returns back to uncocked position opening the diaphragm at the preset position.
3. The overcoming of the gap **4B** (PIC 5) kicks the **H** lever (PIC 1) till the trigger **J** (PIC 4) this will open the shutter till the magnet keeps it open. (or for the default time 1/500 of second when the camera doesn't control the lens). The disk **A** will rotate back a while to reach the uncocked position just around the gap **4B** (PIC 5).

Behind disk **A** there is another disk, the function of this disk is to control the diaphragm aperture, the curve cut on the disk moves the roller **L** inside out, and the roller rotates a lever acting on the diaphragm spindle. The lever **K** is actuated by the aperture disk on the other side of the shutter.

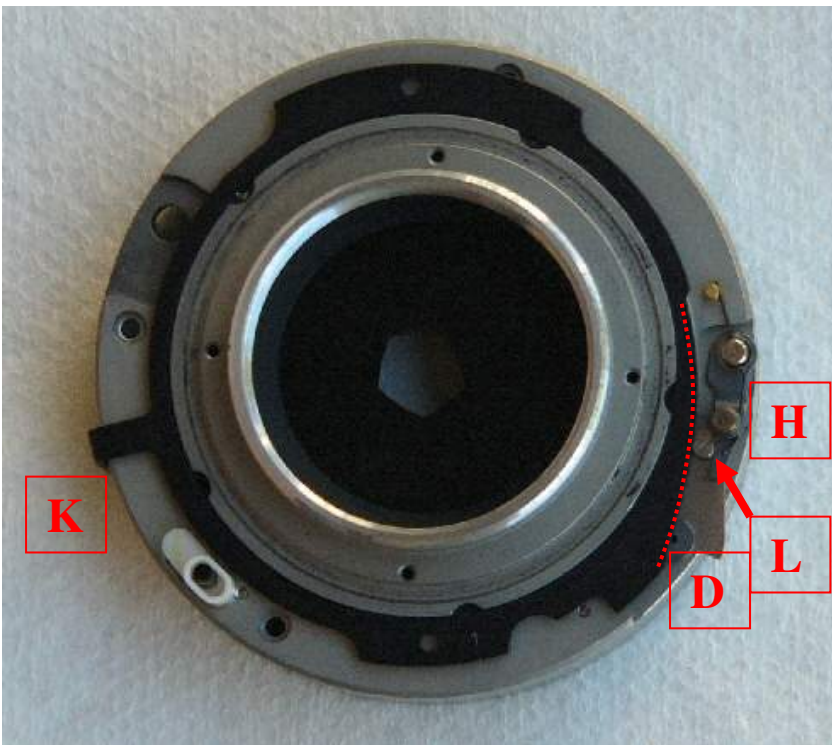

PIC 8: Diaphragm aperture disk located behind disk **A**.

Inside shutter body

The shutter body consists of three chambers::

- One contains the diaphragm.
- One contains the shutter.
- One contains the shutter firing mechanisms.

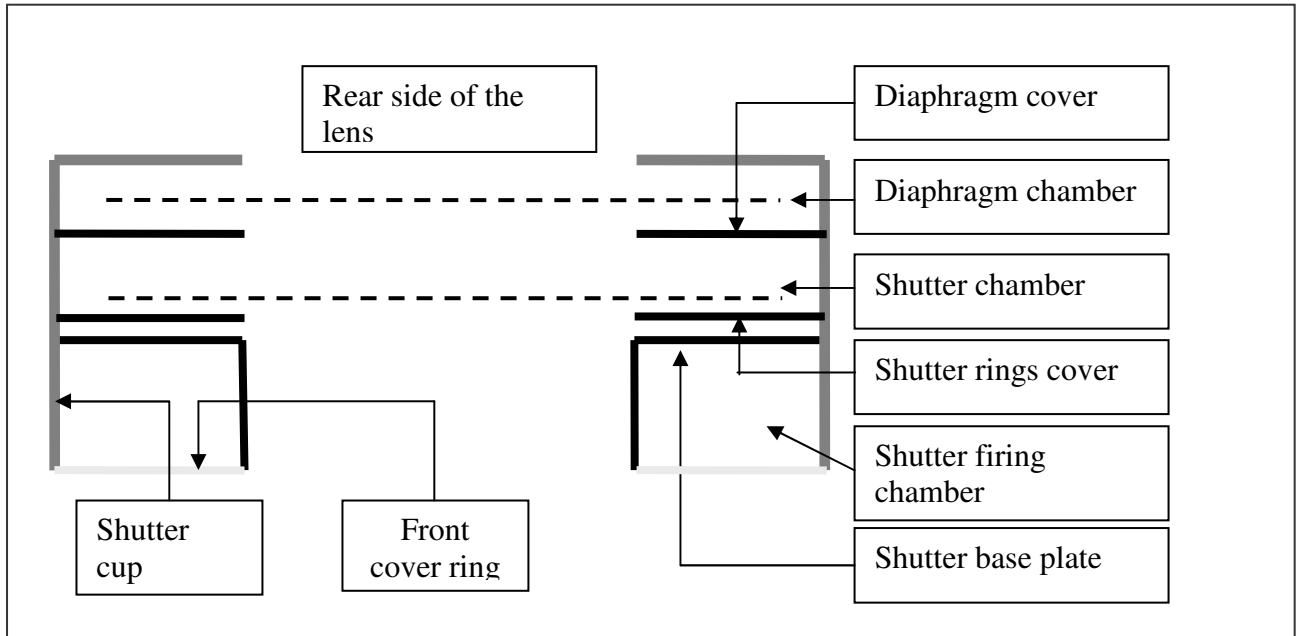

PIC 9: Shutter body section sketch

Diaphragm chamber

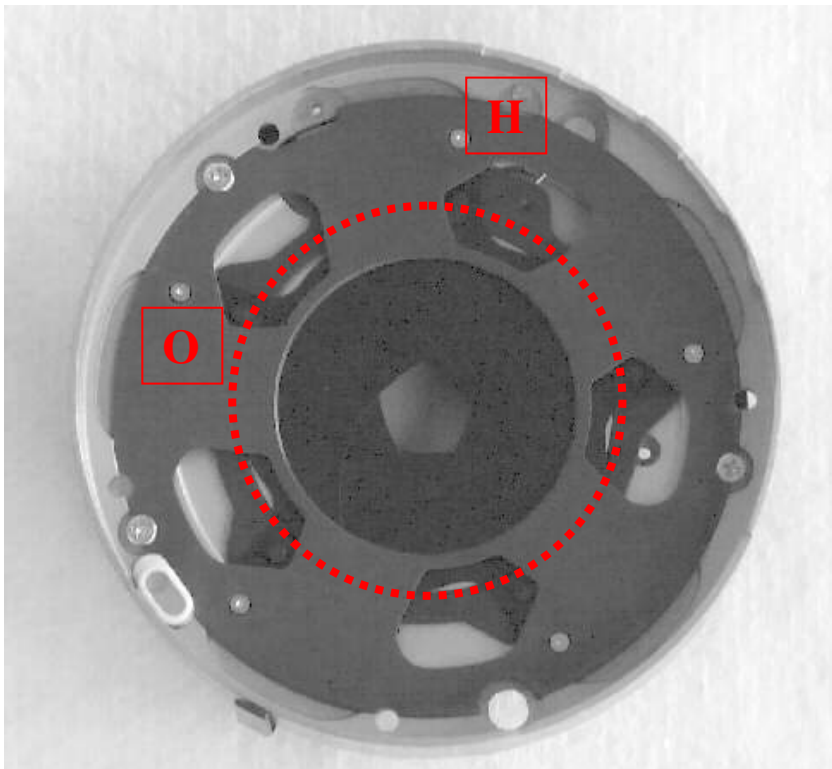

PIC 10: Diaphragm chamber with diaphragm cover

The diaphragm operates in a classical way: the blades pivot on a ring (**O** on PIC 10) rotated by a pin applied on the spindle of lever **H**.

Shutter chamber

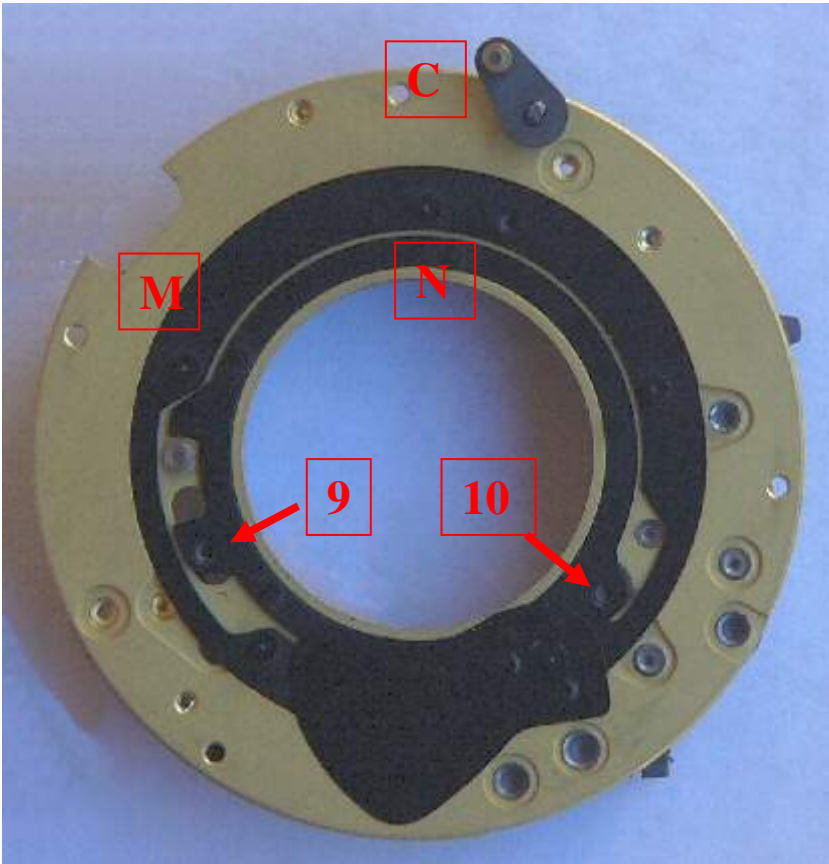

PIC 11: Shutter rings with a single blade (shutter rings cover removed)

M	Shutter external ring
N	Shutter internal ring
9	Flash contact actuating pin
10	Ring N actuating pin
C	The roller C acts on a lever rotating a spindle connected to lever AE (see PIC 13)

Table 4

The PIC 11 shows the shutter chamber with the rings cover removed; one blade has been put in place even without the rings cover.

The blades double pivot on the two disks, the disks act independently but only one at time.

The external disk **M** is driven by lever **AE** as show on PIC 13 it determines the blades position when the lens is uncocked (full close), cocked (full open) or ready to shoot (full close).

The internal disk **N** is driven by the shutter firing mechanism, the disk in its turn drives the flash **X** synch contact.

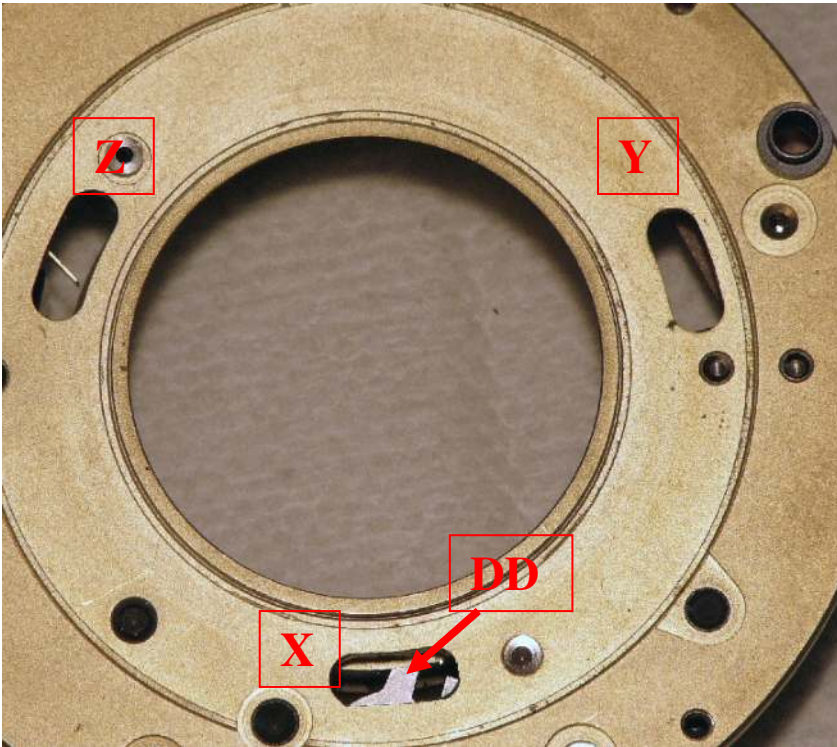

PIC 12: The three slots on the base of shutter chamber: **Z** is the flash X synch slot, note the contact behind, **Y** is the slot through the external disk **M** is driven, **X** is the slot through the internal disk **N** is driven; note the slotted fork behind (disk **DD**) which engages the disk pin.

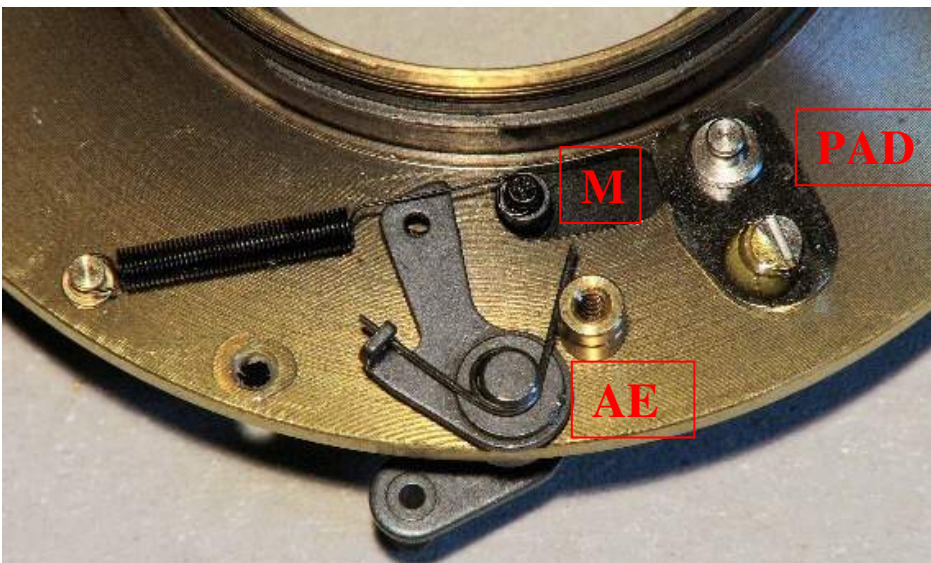

PIC 13: Lever **AE** pushes the disk **M** pin through the slot **Y**; note the spring forces the lever **AE** outward and the pad limiting the span of disk **M** actuating pin. The pad position is fine adjusted by a factory sealed screw. The pad also holds the spring **V** (see PIC 18).



PIC 14: Normal blade (upper left), reversed blade (upper right), special blade (bottom)

The shutter is made of five blades plus a special blade, every blade but the special blade consists of two welded petals: the full petal and the reinforcement petal; the special blade is only a loose reinforcement blade. Four of five blades have the reinforcement faces the front of shutter (lens) but one has the reinforcement on the other side.

The flower is arranged starting with the special blade then proceeding counter clockwise with normal blades till the fifth blade that is the reversed one lies over the special blade. With this arrangement isn't necessary to overlap the first blade to the last one.

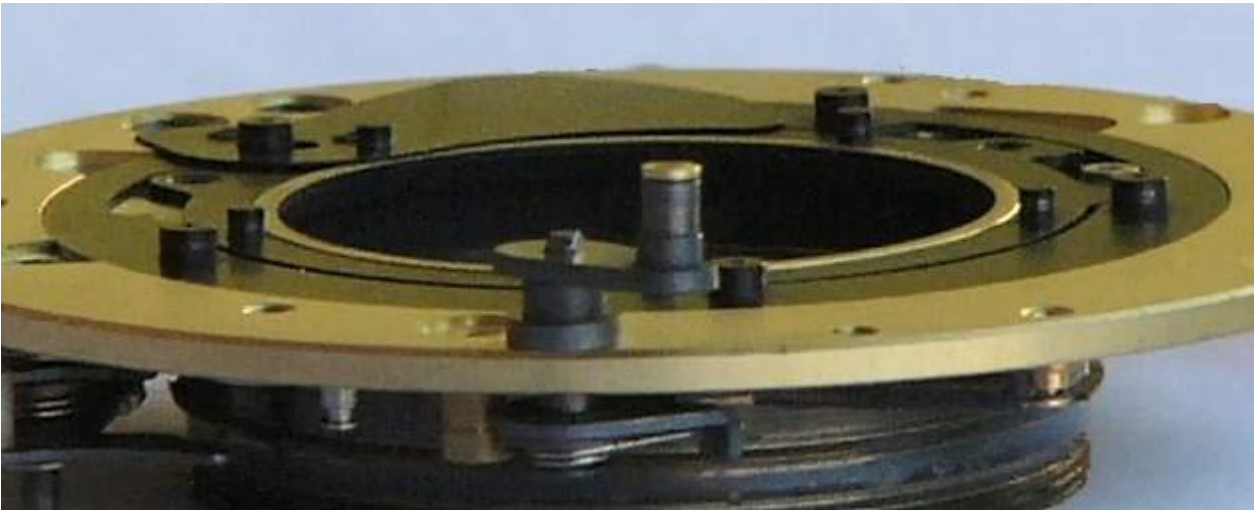

PIC 15: Side view of the shutter disks

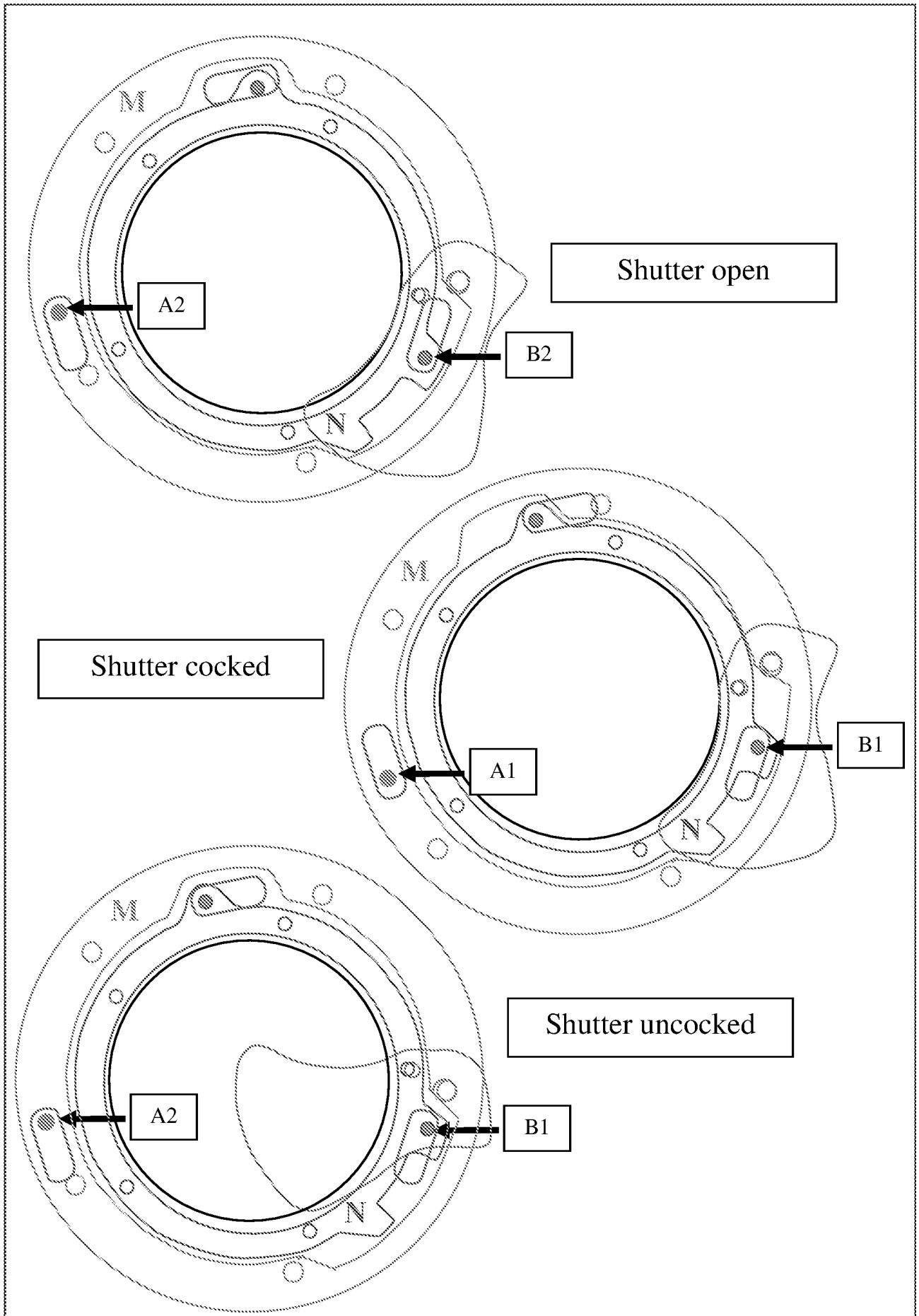

PIC 16: Sketch of M and N disk positions.

The positions of disk **M** and **N** are summarized in the following table:

M position	N position	Status
A2	B1	Shutter uncocked (close)
A1	B1	Shutter cocked (open)
A2	B2	Shutter open
A1	B2	Not available

Table 5

Shutter firing chamber

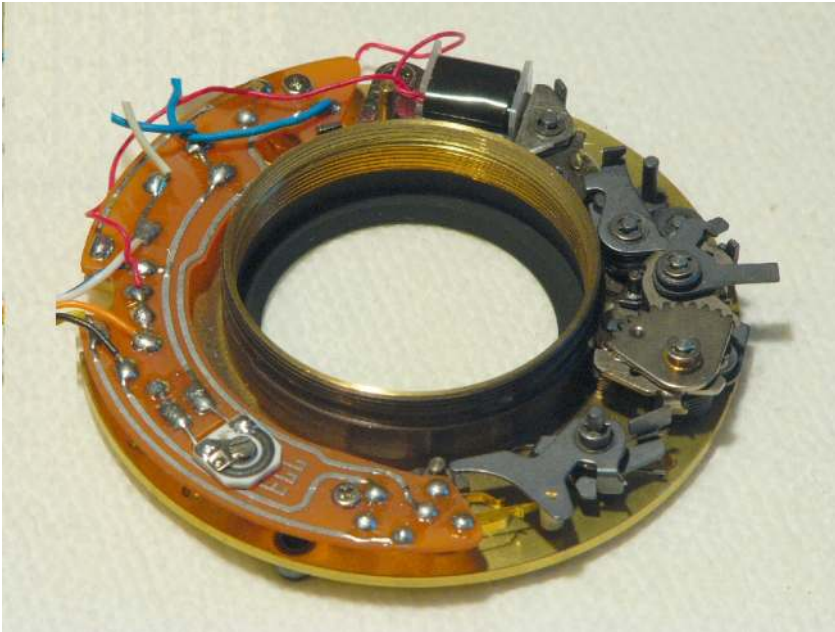

PIC 17: Shutter firing chamber, cogged ring and shutter open trigger removed.

The shutter firing chamber contains the following subsystems:

- Shutter charge and trigger subsystem: this subsystem loads and releases the shutter open/close subsystem.
- Shutter open/close subsystem: it controls the shutter open/close operations.
- Shutter time subsystem: it controls how much time the shutter remains open.
- Electric control subsystem: this subsystem includes the shutter electric devices.
- A small assembly controls the movement of disk **M** (see PIC 12)

Shutter charge and trigger subsystem

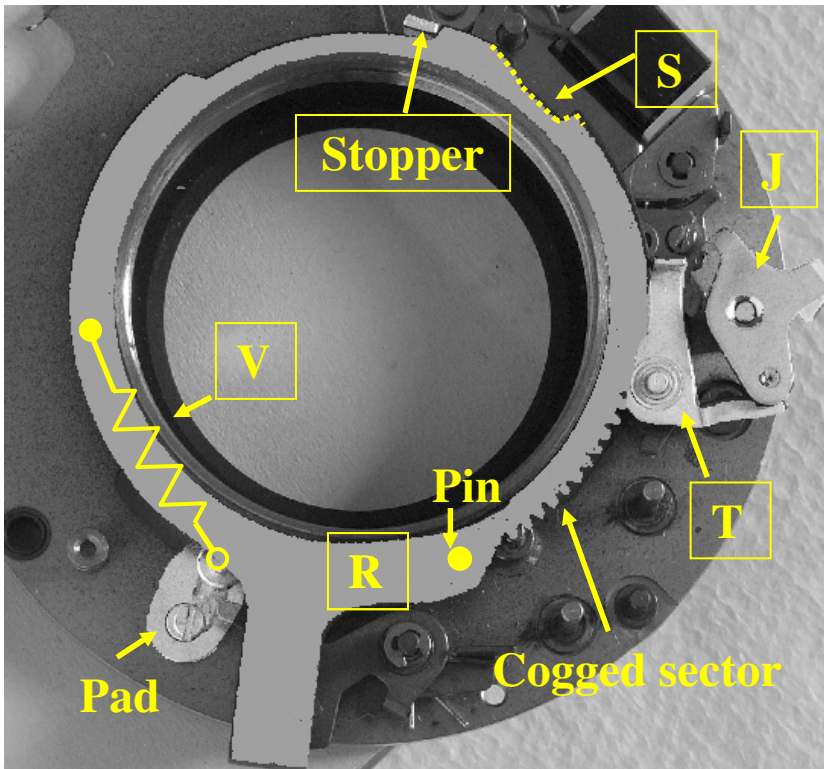

PIC 18: Shutter charge and trigger subsystem in rest position

The cogged ring (**R** on PIC 18) when the shutter is cocking, is turned clockwise (front side view) by lever **I** (PIC 2), loading the spring (**V** on PIC 18) till the stopper blocks its rotation reaching the left end of the slot, the hook lever (**T** on PIC 18) is spring loaded to push leftward and when it reaches the slot (**S** on PIC 18) it engages it preventing **R** to turn back (see PIC 19). If the shutter opening trigger (**J** on PIC 4 and PIC 18) rotates counter clockwise, when the shutter is cocked, it forces **T** to rotate rightward releasing **R** which in turn will rotate back to its rest position.



PIC 19: Hook lever **T** engages cogged ring **R**.

Shutter open/close subsystem

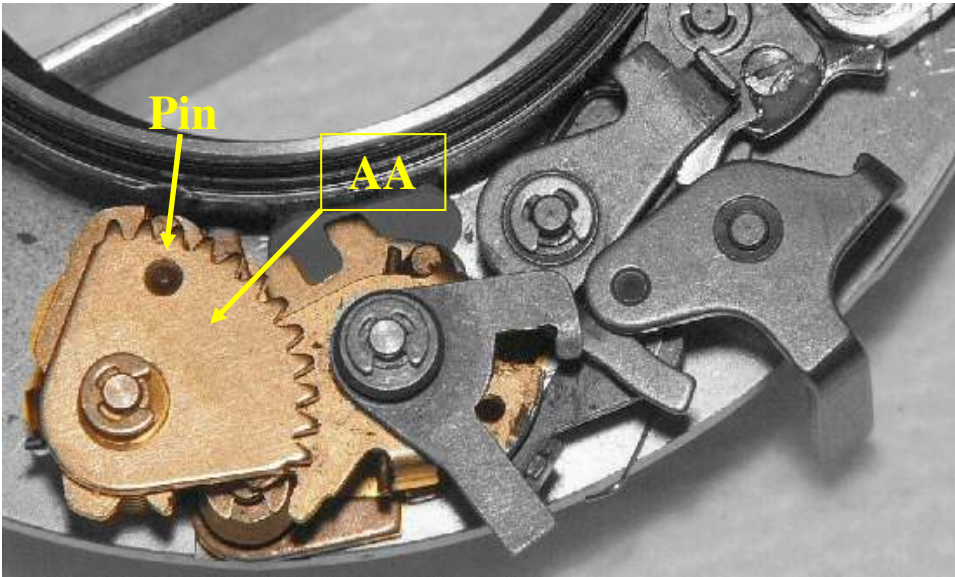

PIC 20: Highlighted: the shutter open/close subsystem.

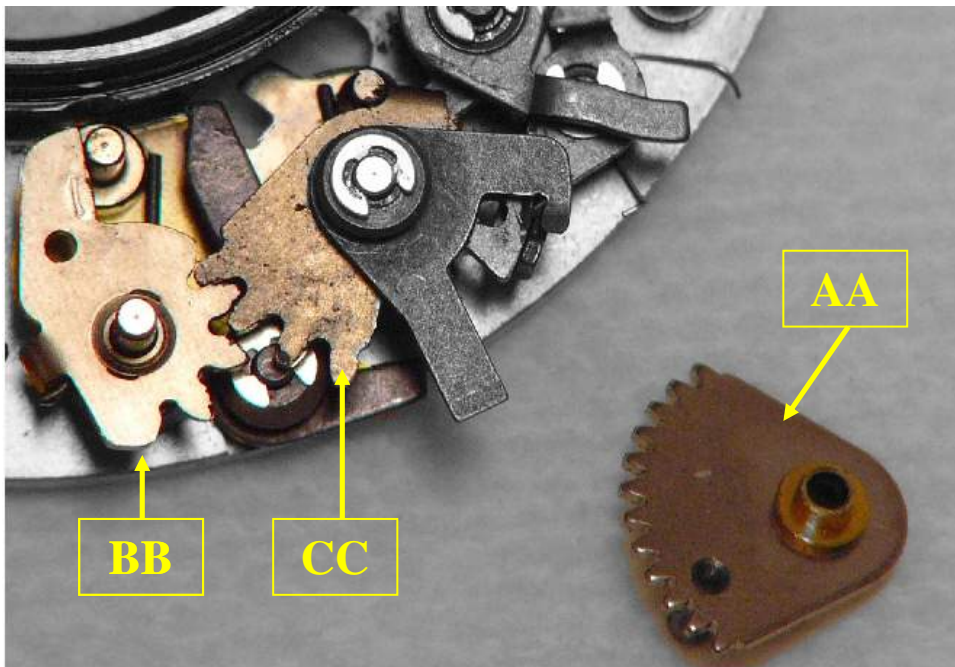

PIC 21: Highlighted: the shutter open/close subsystem, cogged sector AA taken apart.

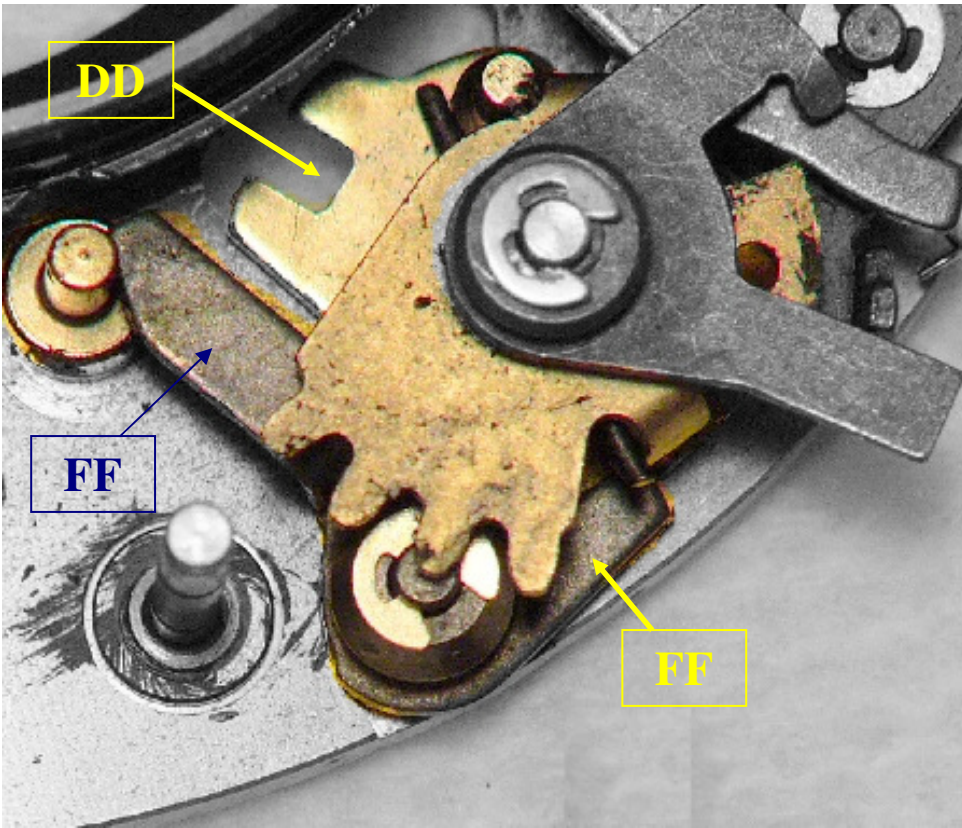

PIC 22: Highlighted: parts of the shutter open/close subsystem.

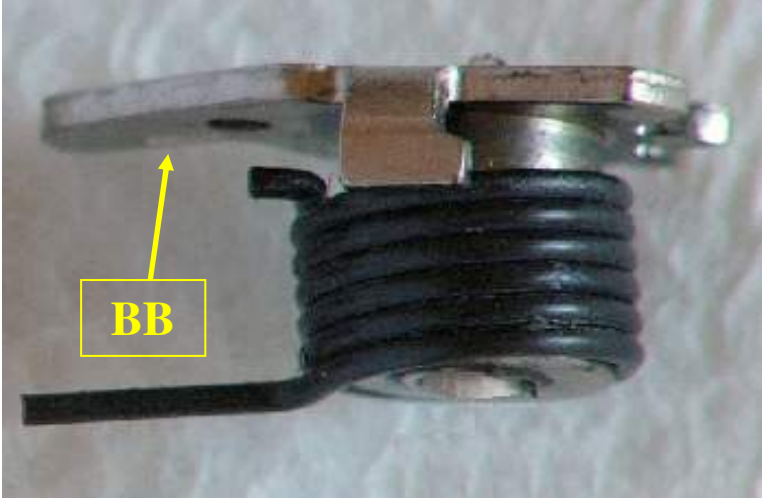

PIC 23: Left spring assembly.

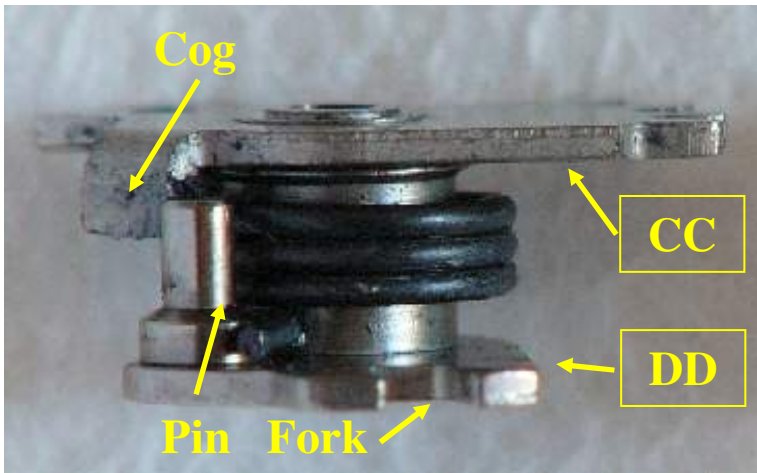

PIC 24: Right spring assembly (Rear view).

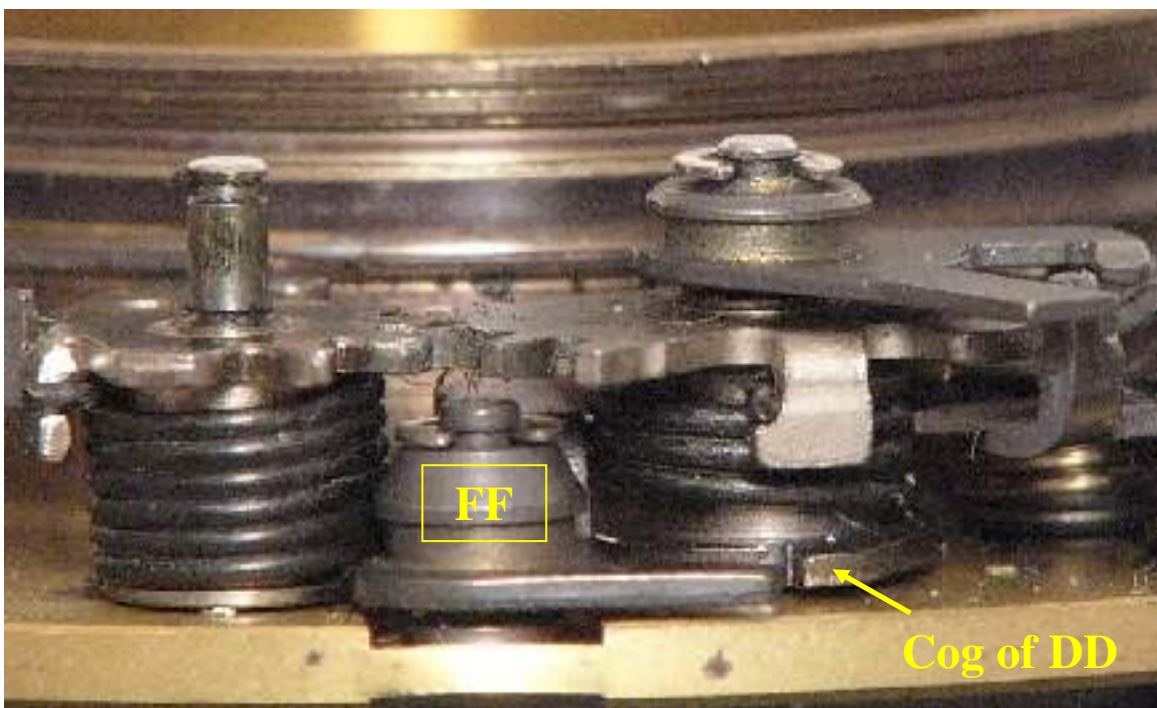

PIC 25: Spring assemblies.

Shutter open/close subsystem description

There are two spring assemblies:

The left element has a spring grounded at low end to the shutter housing and at top end to a cogged sector **BB** (See PIC 21 and 23).

Over the cogged sector **BB** there is another cogged sector **AA** (PIC 20 and 21) turning on the same spindle of **BB** but independent from the underlying one.

The top cogged sector **AA** has a pin (PIC 20) dragging the underlying cogged sector **BB** when **AA** rotates counter clockwise; this rotation loads the left element spring.

The right element (PIC 24) has a spring grounded at low end to a disk **DD**; this disk has a fork driving the pin of internal shutter ring **N**. Disk **DD** also has a cog and a pin prolonging from it (PIC 24 and 25). The right element spring top end is grounded to a cogged sector **CC** turning on the same spindle of disk **DD** but independent from it.

The cogged sector **CC** has a vertical cog facing the pin of disk **DD** (see PIC 24).

The cogged sector **CC** is geared on the cogged sector **BB** so when **BB** rotates counter clockwise **CC** rotates clockwise and vice versa.

At the same level of disk **DD** there is a “L” shaped lever **FF** (PIC 22) pivoting on its knee and spring loaded to stay leftward; this lever at one end engages the cog on disk **DD** (see PIC 25), on the other end the lever **FF** is dragged by the pin on cogged sector **AA**.

Cogged sector **CC** also has a cam which engages the trigger lever **W** (see above).

The pin on disk **DD** is engaged by lever **EE** (see above).

The mechanism at rest position is showed on sketch **1** of PIC 26, to cock it the ring **R** rotates clockwise turning the cogged sector **AA** counter clockwise. The pins on cogged sector **AA** drags counter clockwise the cogged sector **BB**, which loads the left element spring.

Rotating the pin of cogged sector **AA** counter clockwise also permits that the lever **FF** pushes by its spring will go leftward engaging the cog on disk **DD** and preventing the clockwise rotation of disk **DD**.





On rotation of cogged sector **BB**, also cogged sector **CC** could rotate on its turn clockwise, but due to disk **DD** it cannot rotates clockwise, the right element spring will be loaded.

At the same time the trigger lever **W** traps the cam end of cogged sector **BB** preventing **BB** to rotate counter clockwise and locking the mechanism on cocked state (see sketch **2** on PIC 26).

When the system is fired, on clockwise rotation of ring **R**, the cogged sector **AA** rotates clockwise and its pin forces the lever **FF** to go rightward freeing the disk **DD** which will be rotate clockwise by the right element spring. The rotation of disk **DD** moves the fork at open shutter position and pushes its pin against lever **EE** which preloads the release of trigger lever **W**. The mechanism will be in open state as showed on sketch **3** of PIC 26.

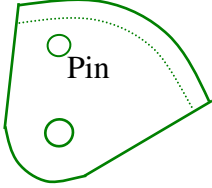
When the trigger lever **G** will pull out, freeing the cogged sector **CC**, it will rotate counter clockwise because the discharging of left element spring through cogged sector **BB**, this rotation causes the vertical cog of cogged sector **CC** drags the disk **DD** pin to the shutter close position.

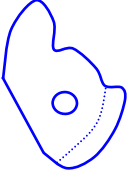
The mechanism returns back to its rest (uncocked) position.

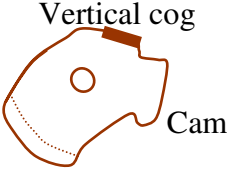
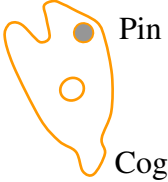
Cogged sector AA		Lever FF	
Cogged sector BB		Trigger lever W	
		Lever EE	
Cogged sector CC		Disk DD	

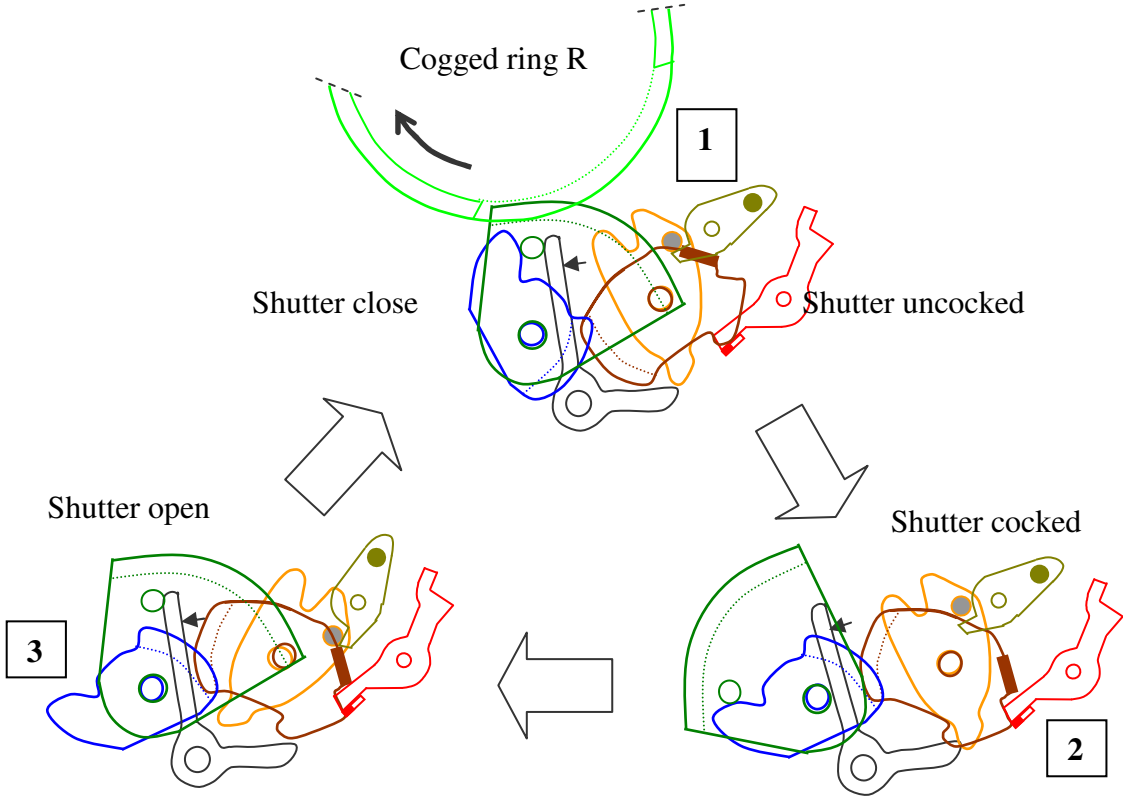

PIC 26: shutter open/close subsystem.

Shutter time subsystem

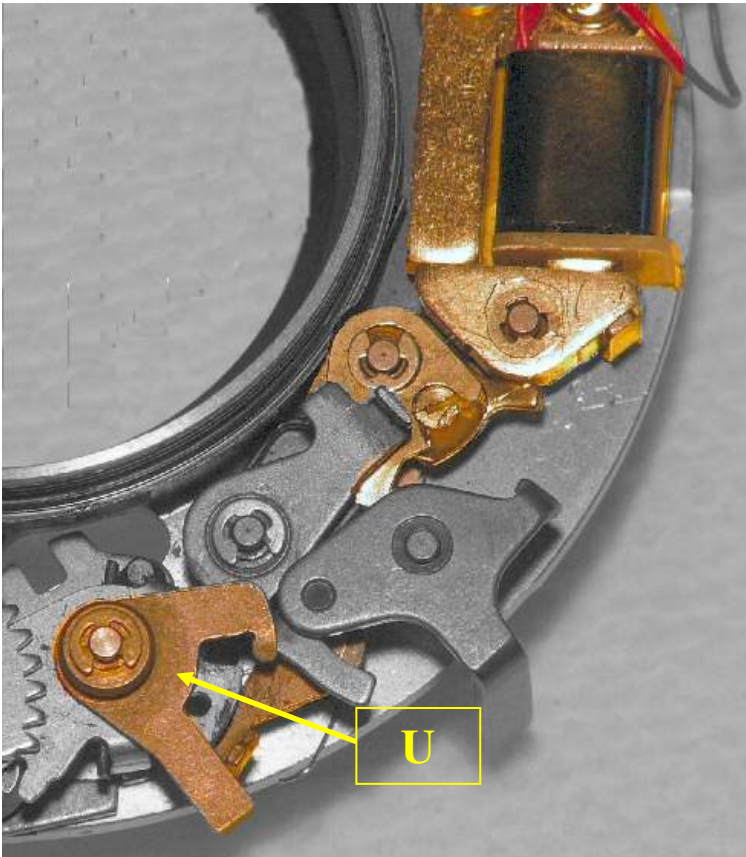

PIC 27: Highlighted: parts of the shutter time subsystem.

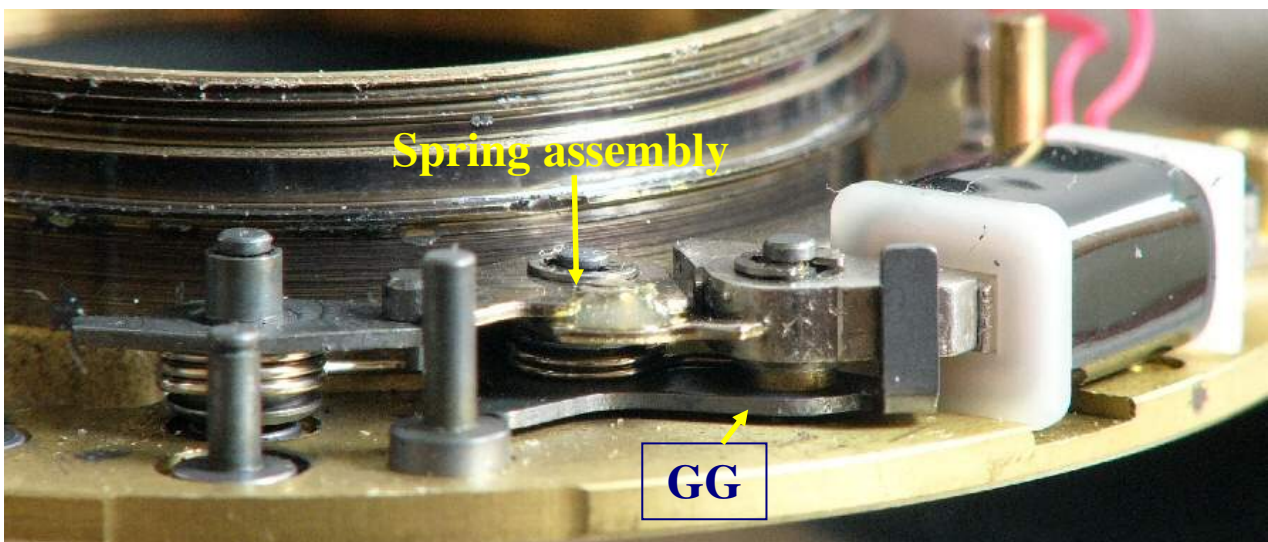

PIC 29: Shutter time subsystem

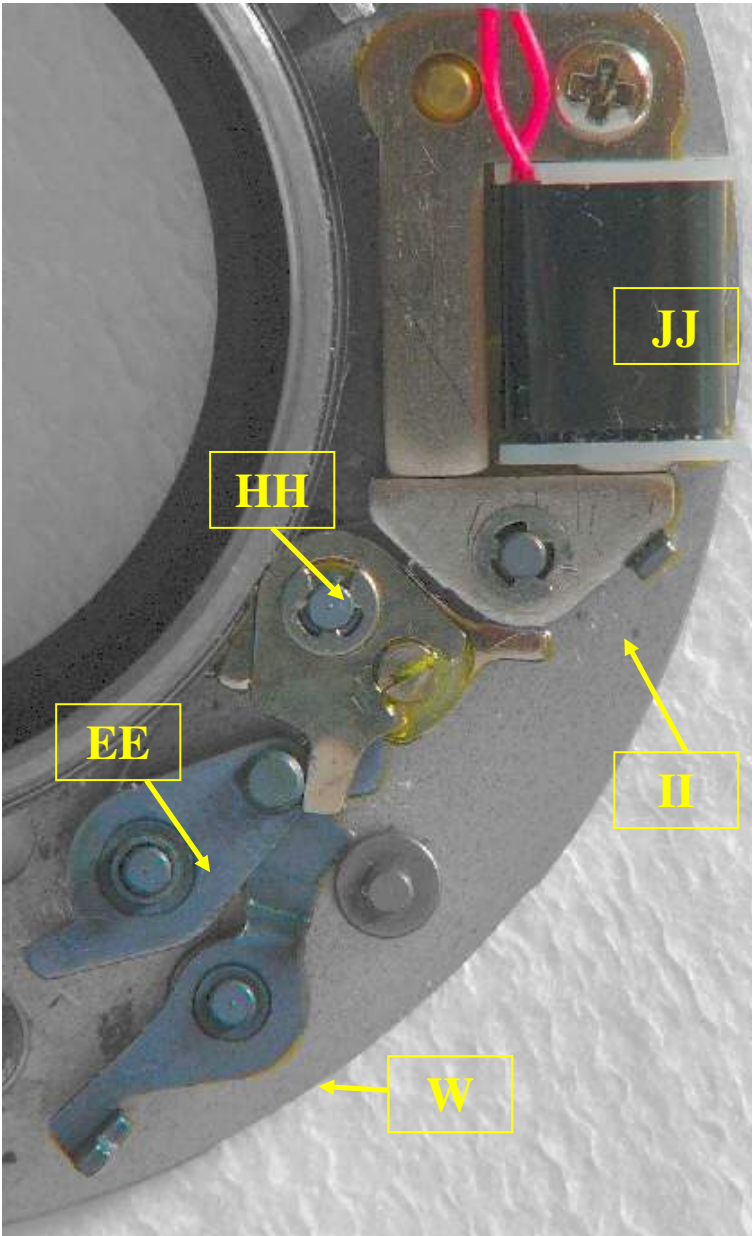

PIC 28: Highlighted: parts of the shutter time subsystem

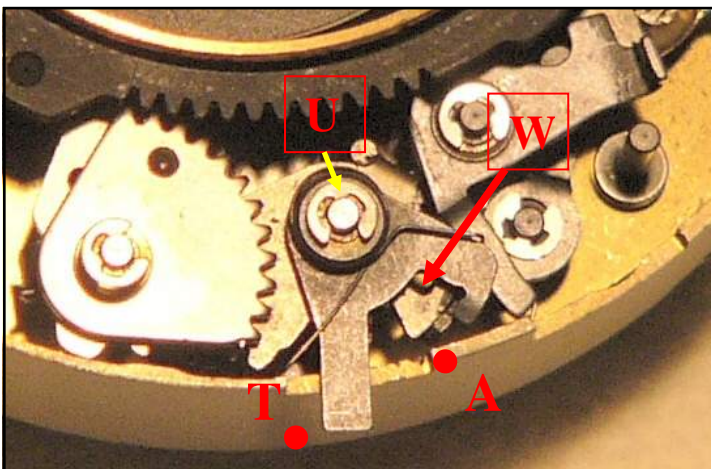

A/T Selector position

PIC 30: A/T selector latch

The time control subsystem includes:

Spring assemblies (see PIC 29) where a top device (**HH** on PIC 28) is free to rotate on its spindle but limited on a side by a cog engaged by the pin of a lever (**EE** on PIC 28) which could rotate **HH** counter clockwise. Tied back to **HH** there is a plate with a pin keeping **HH** away from a magnetic anchor (**II** on PIC 28) and preventing **HH** to turn clockwise.

The plate is fixed to **HH** by a screw which permits to adjust the pin extension. This screw is factory sealed. The pin extension adjustment allows fine-tuning of the system inertia to get the right delay to obtain the minimum (default) shutter shoot time of 1/500 sec.

At the bottom of spring assembly there is a device (**GG** on PIC 29) turning on the same spindle as **HH**, but independent from it, and constrained by a spring grounded on the shutter housing to proceed counter clockwise. The device **GG** has a cog engaged by a lever (**W** on PIC 28) and holds the magnetic anchor **II**.

The lever **EE** has a pin pushing the device **HH** clockwise and a spring driving **EE** to turn clockwise.

The trigger lever **W** has an extension that hooks the cog on **GG** and when **GG** turns clockwise the other sides of **W** turns counter clockwise freeing the shutter close mechanism.

In rest condition lever **EE** by means of its pin pushes **HH** clockwise, **HH** rotation is blocked by anchor **II**. Due to its spring, **GG** is pressed counter clockwise and stopped by anchor **II** which closes the electromagnet joke. The lever **W** freed from **GG** pressure is turned clockwise (see sketch 1 on PIC 31).

When **EE** turns counter clockwise because rotation of disk **DD**, **EE** releases **HH** which in turn releases the anchor **II** which if not attracted by electromagnet (**JJ** on PIC 28), leaves device **GG** free to turn clockwise. Device **GG**, rotating, pushes lever **W** counter clockwise unblocking its trigger hook (see sketch 2 on PIC 31).

In opposition, if the electromagnet is energized anchor **II** doesn't move locking **GG** until the electromagnet is de-energized. (See sketch 3 on PIC 31)

Summarizing: in shutter shot phase at the end of shutter open action the rotation of disk **DD** triggers lever **HH** which in turn starts the delay mechanism to determine the shutter open time. There are three cases causing the release of the trigger **W** and starting the shutter close phase:

1. Default or minimum time (1/500 of sec): in this case **W** is triggered after the intrinsic delay of the system without any external action.
2. Controlled mode: in this case the energized electromagnet freezes the rotation of device **GG** and **W** will not be triggered until the electromagnet will be de-energized, The shutter open time is determined by the electromagnet energized time period.
3. Manual mode: That mode is the same as case 1 but at the end of the chain **W** is framed by A/T selector latch (**U** on PIC 27 and 30), which determines when trigger **W** will start the shutter close phase.

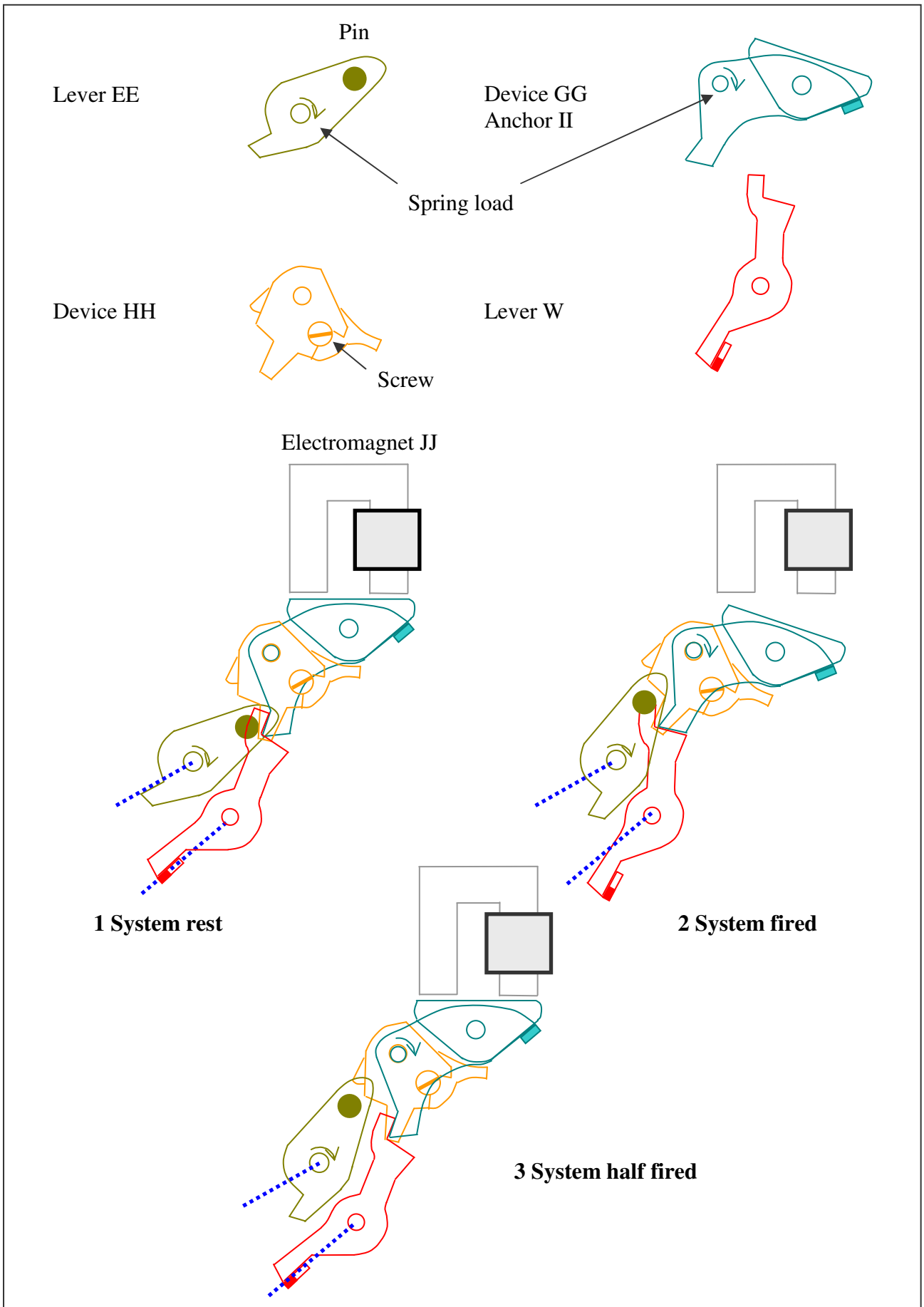

PIC 31: Time control elements sketch

Electric control subsystem

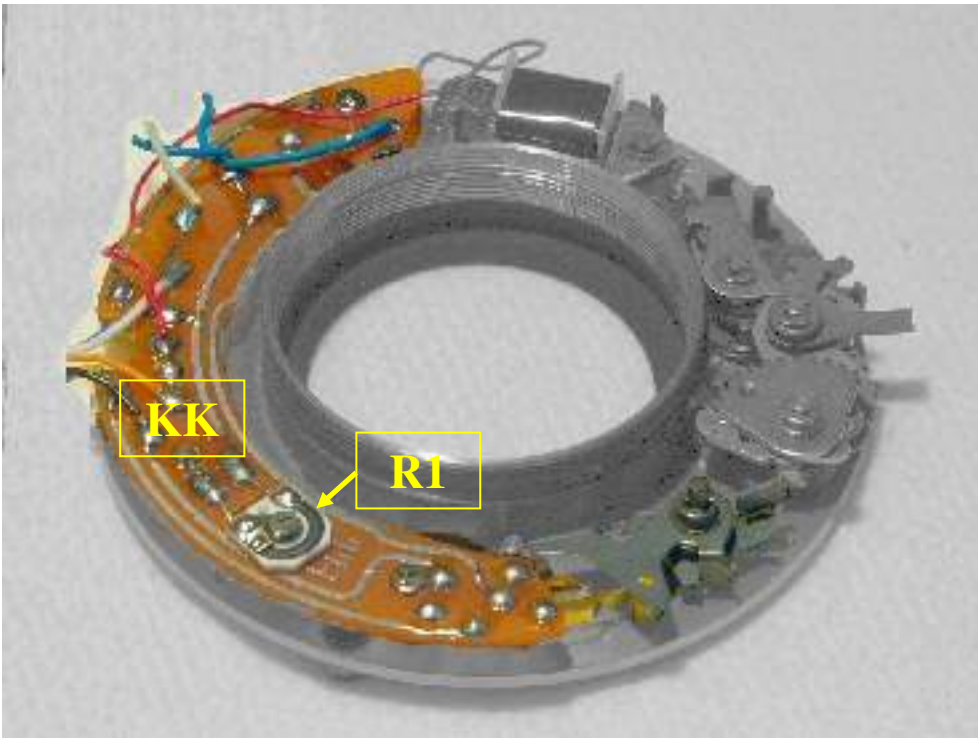

PIC 32: Highlighted: parts of the electric control subsystem

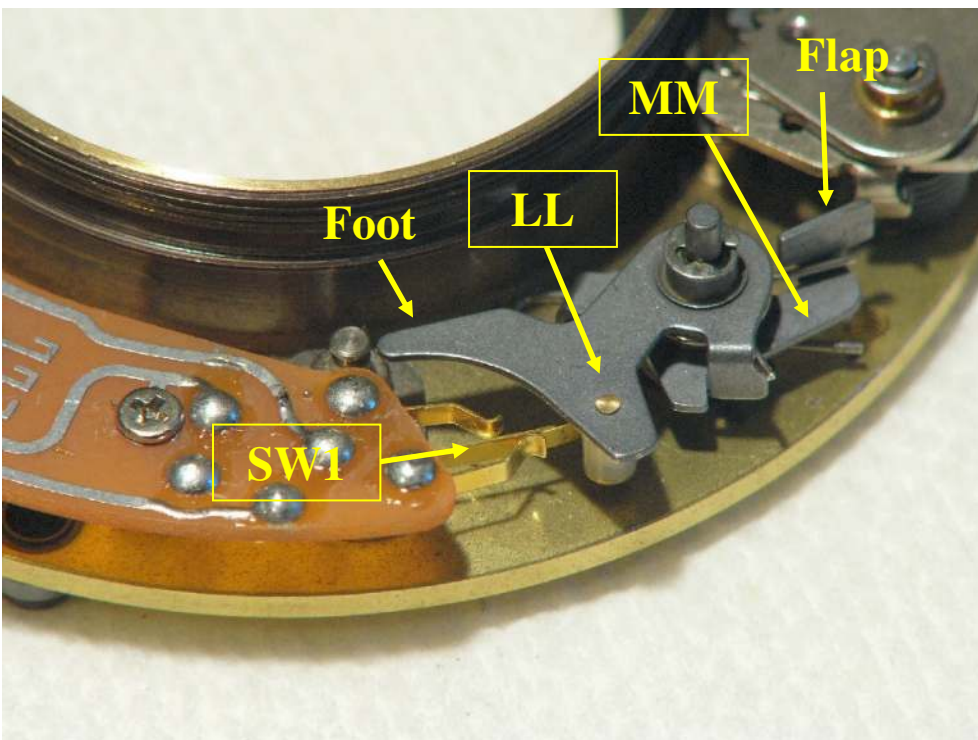

PIC 33: Parts of the electric control subsystem

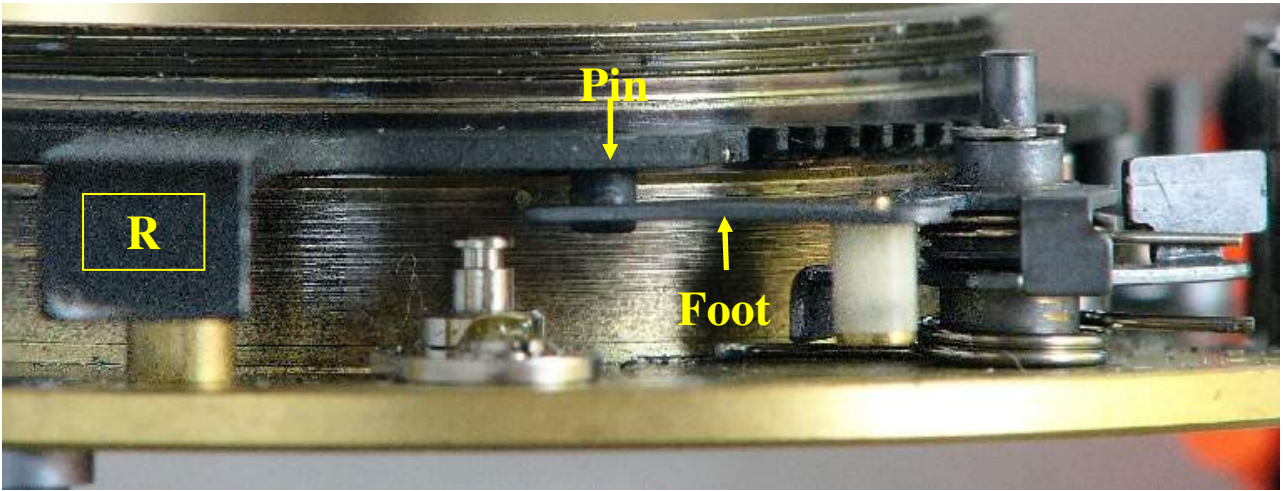

PIC 34: Parts of the electric control subsystem

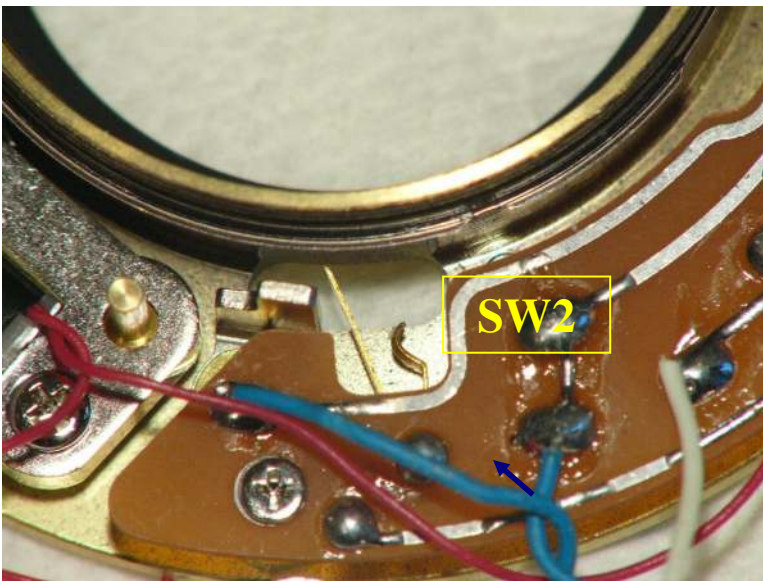

PIC 35: Parts of the electric control subsystem

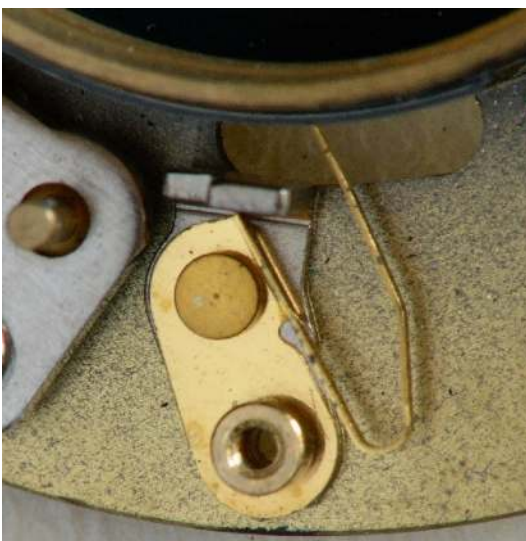

PIC 36: Part of SW2

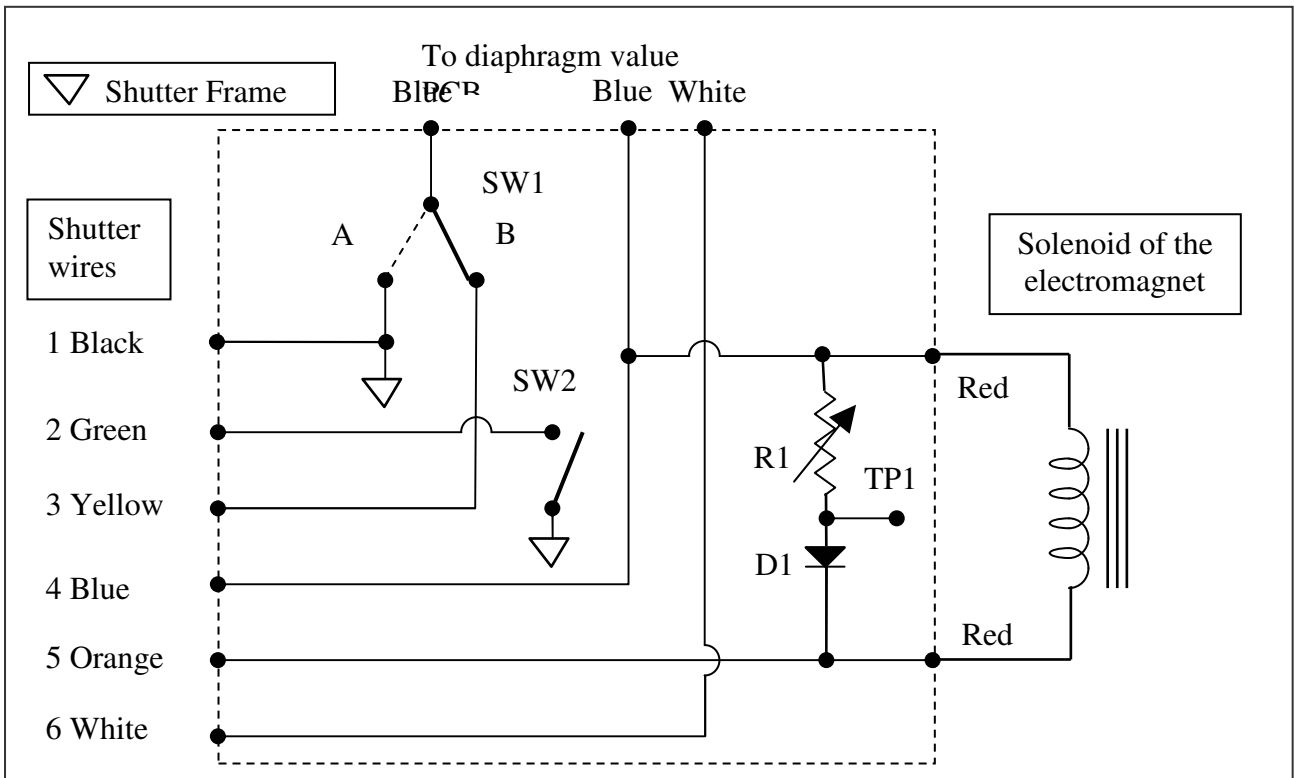

PIC 37: Schematic diagram electric control subsystem

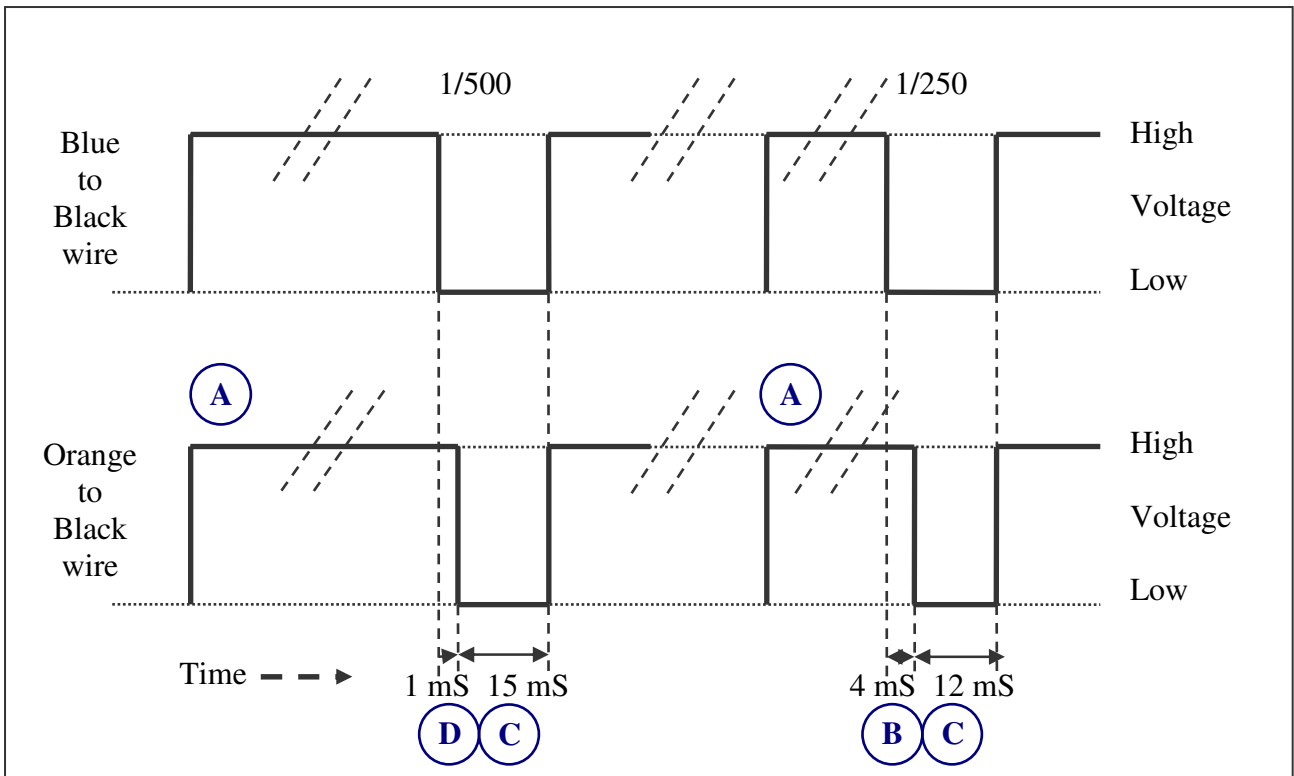

PIC 38: Electric timing diagram.

The electric control subsystem contains the shutter electric parts; which schematic diagram is sketched on PIC 37.

A toggle switch (SW1 on PIC 37 and 33) is controlled by a set of levers turning on the same spindle (MM and LL on PIC 33).

MM has a spring grounded to shutter cup loading it counter clockwise, it also has another spring connects it to **LL** and a flap facing a cog on cogged sector **BB**.

LL has a plastic bean pushing **SW1** contacts and a foot facing the orbit of the pin of cogged ring **R**. When the shutter is at rest position (uncocked) the levers are both rightward thus the **SW1** is on position B (see PIC 37). When the shutter is cocked the cogged sector **BB** rotating counter clockwise pushes the flap of **MM** resulting on clockwise rotation of **MM** but at the same time the pin on cogged sector **BB** closed to the foot of **LL** doesn't permit the rotation of **LL**, thus **SW1** remains on position B and the spring connecting **MM** to **LL** will be loaded. When shutter opens, **BB** rotates back to its rest position taking off the pin from the foot and permitting **LL** to rotate clockwise because its spring, thus moving **SW1** to A position. When the shutter closes **SW1** returns back to B position. Definitely **SW1** stays on A position while shutter is open.

SW2 (see PIC 35, 36 and 37) is the flash X synch contact, it is operated by a pin on the internal disk **N**, and it will be closed when shutter is full open and opened when shutter is full close.

The diode D1 and trimmer resistor R1 are provided to cut-off the self inducted electromotive force generated by the electromagnet solenoid, the cut-off is fine adjusted by trimmer R1 which is accessible, through a hole, from the front side of the shutter (see PIC 41) but it is factory adjusted.

The electromagnet will be activated applying a voltage between its leads; the positive pole is connected to the orange wire while the negative pole must be connected to the black wire to operate that happens in this way:

- When the camera release button is half pressed the orange wire will be energized (time A on PIC 38) (camera release button is double action, when half pressed it closes an electric contact but you haven't any feeling of that because notoriously any camera produced by Bronica has the autofocus feature defective). When the button is full pressed it mechanically starts the shot action.
- If the A/T selector is at A position the switch on the diaphragm value PCB **AB** (see PIC 44) is closed so when **SW1** achieves its A position the electromagnet is energized.
- At the same time the camera is sensing the blue wire, and when the voltage drops from positive to zero, it starts a timer supplying power to the orange wire for the shutter open time interval. (I.e. time B on PIC 38); note: at 1/500 of sec the electromagnet will be not energized at all but the intrinsic delay of circuits (time D on PIC 38).
- When the shutter time has expired the orange wire will de-energized for a time, permitting the shutter closing phase (time C on PIC 38).
- The camera senses the A/T selector using the yellow wire, in order to avoid energizing the electromagnet if A/T selector is at T position.

Front side

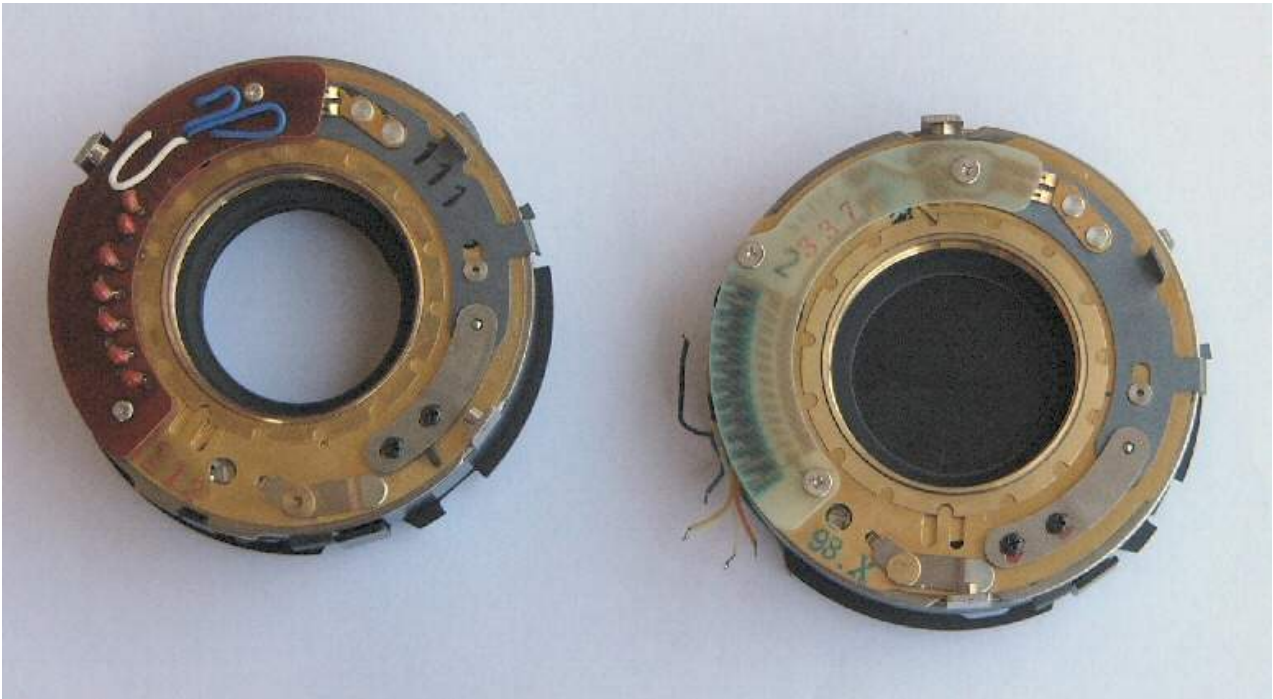

PIC 39: Old and new style of Seiko shutter.

There are 2 types of Seiko shutters:

- ❑ Old type used on Zenzanon S, M, MC lens, it has 7 aperture stops although mechanically it is possible to hold the half position and the diaphragm acts according, the half position isn't notified to the metered prism. It is identifiable by the reddish printed circuit board with seven resistors shaped like pillows on the upper side.
- ❑ New type used on Zenzanon PS, PE lens, it has 13 aperture stops including the half positions and it fully notifies that to the metered prism. The circuit board is green without any component on the upper side.



PIC 40: Front cover ring: note the holes to access the trimmer **R1** and test point **TP1** (see PIC 37). Note also the access to the screw to adjust the device **HH** (see PIC 28 and 31).

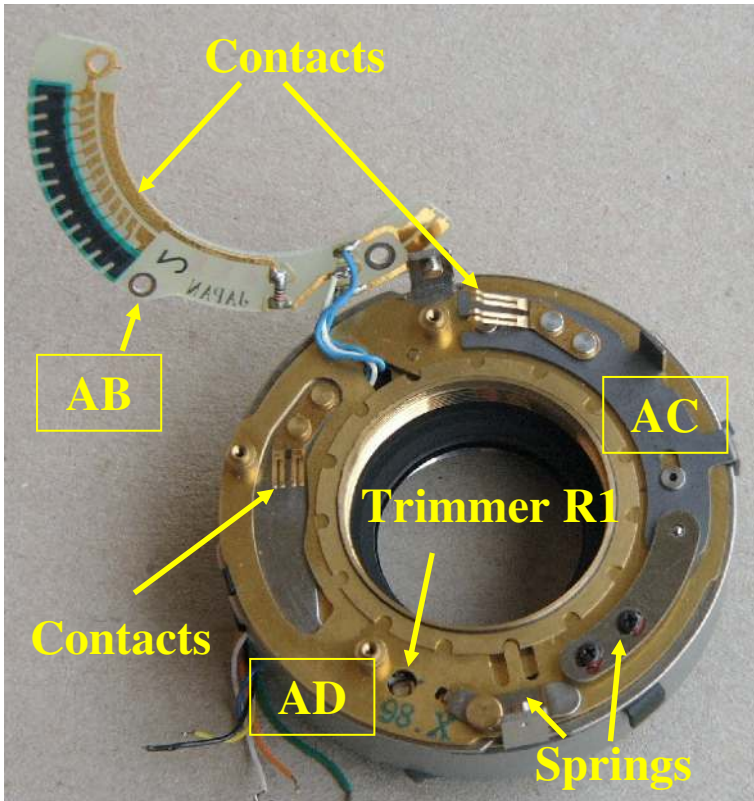

PIC 41: Shutter front with printed circuit board **AB** detached.

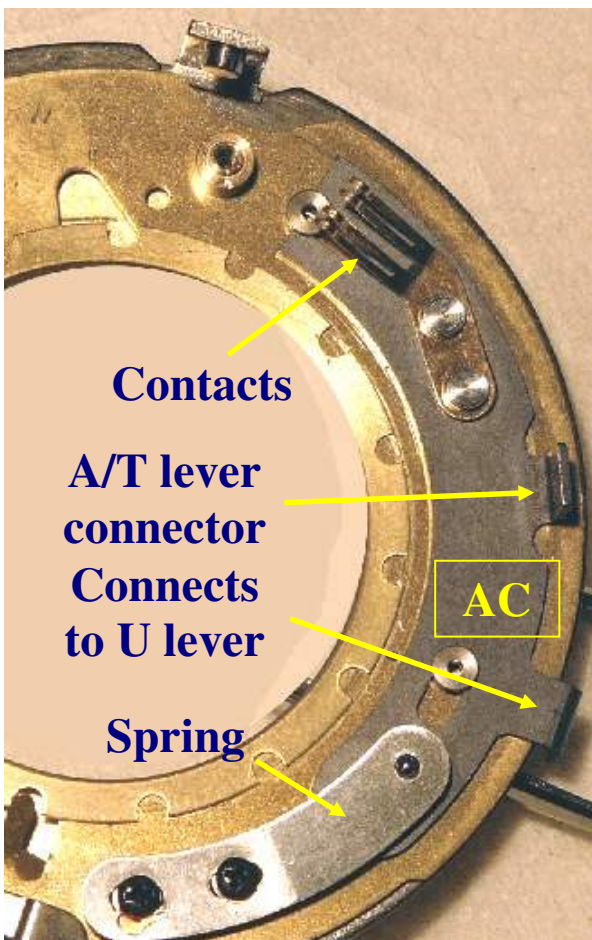

PIC 42: A/T slide **AC**

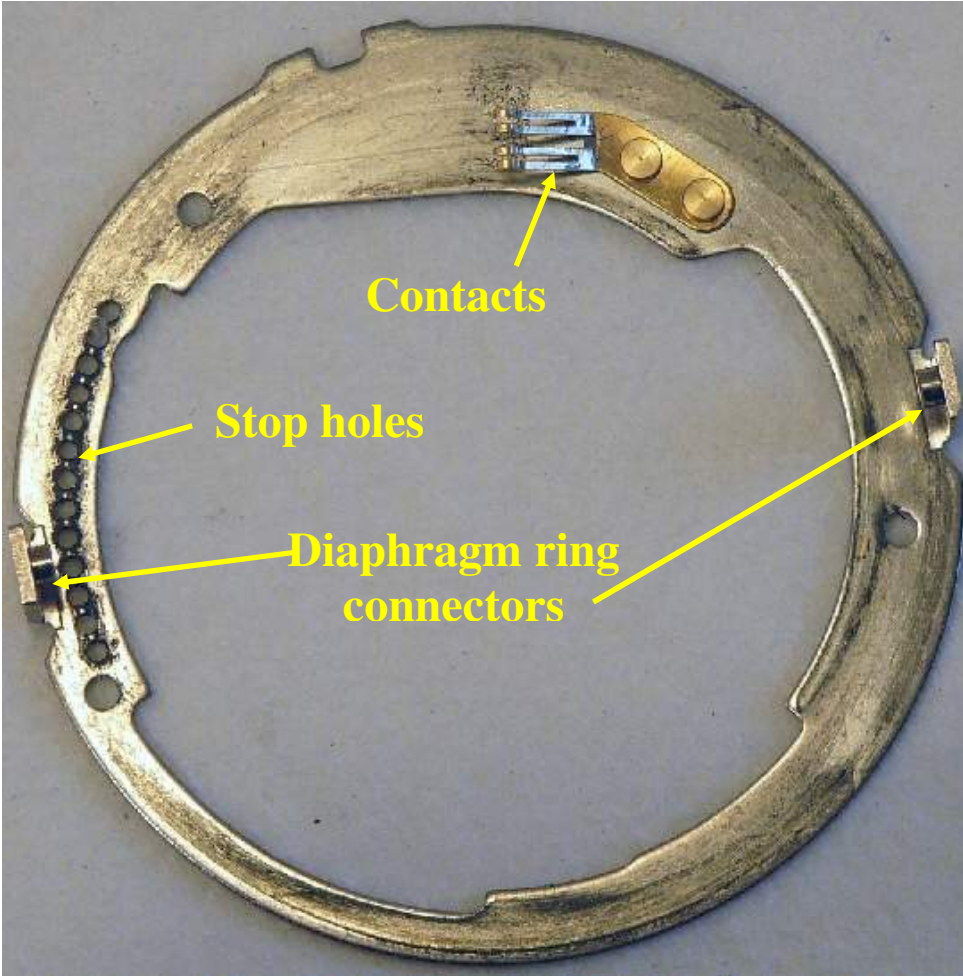

PIC 43: Inner ring

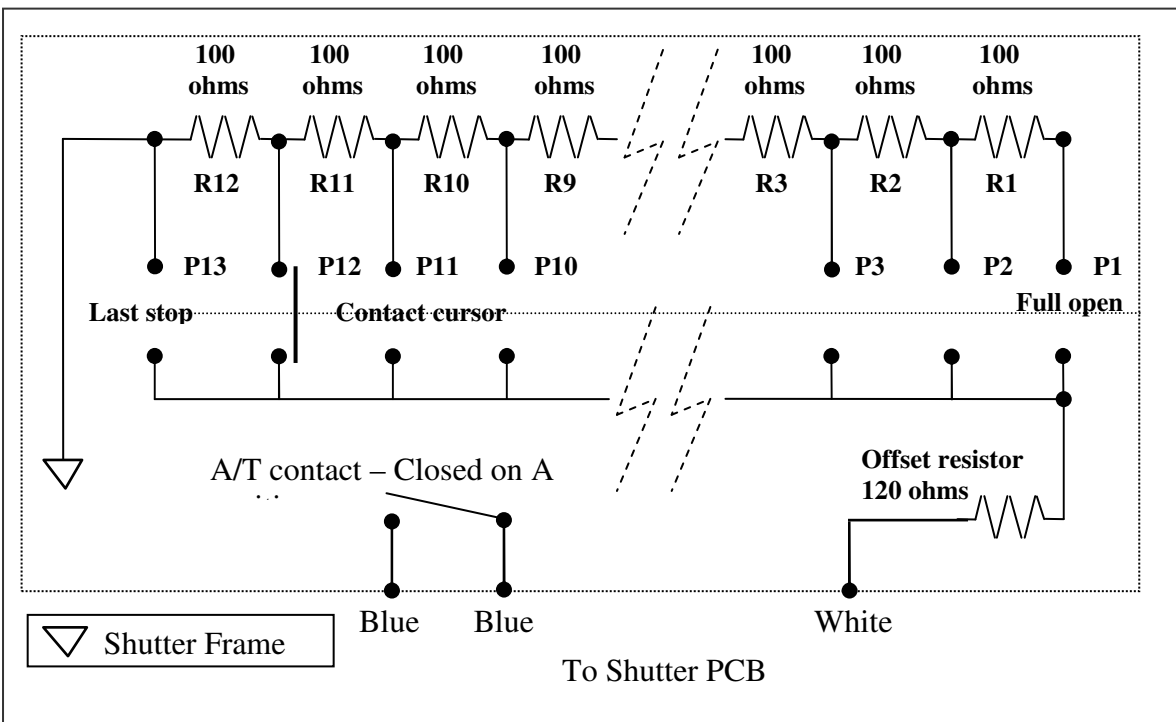

PIC 44: Schematic diagram of the diaphragm value printed circuit board AB. (new style)

The shutter front side includes:

A front ring (**AD** on PIC 41) holding a printed circuit board (**AB** on PIC 41) and a slide (**AC** on PIC 41). There are a hole on **AD** permitting the access to the trimmer **R1** (see PIC 37 and 33) and a slot permitting the contacts of the inner ring to pass through.

The slide **AC** (see PIC 42) can stay on 2 positions depending on the A/T lever on the lens (remember that on A position the shutter operates by the speed selected on the camera while on T position the shutter is opened pushing the shutter release button and closed when the lever is moved back to A position). When the slide **AC** is full leftward a slide contact closes a circuit on PCB **AB**, and an extension on **AC** push the A/T selector latch **U** (see PIC 30) to A position. When **AC** is at right position the contact is retracted from **AB** thus the circuit is open and the extension releases A/T selector latch **U** to T position. **AC** has a spring grounded to **AD** pushing a ball to **AC** which has two holes determining the two operative positions.

An inner ring (see PIC 43), which is driven by the diaphragm ring on the lens through 2 connectors, it is rotated by the front ring **AD** but only on 13 positions (7 on the old style shutter) determined by a ball inserted between a spring on **AD** and 13 (7) holes drilled on it. The inner ring also has the contacts pass through **AD** determining the resistance value used by metered prisms to get the aperture value.

The diaphragm value printed circuit board **AB** acts like a discrete potentiometer: turning the diaphragm ring the resistance between white wires and shutter frame (black wire) will change; the resistance value is read by metered prisms to determine the present diaphragm aperture. The metered prism always meters with full open diaphragm and must compensate for the current diaphragm aperture using the resistance values. On the new style shutter there are 12 resistors and an offset resistor while on the old style only 7 without offset resistor. The relation between F and resistance in ohm should be:

F	2.8	3.5	4	5.6	8	11	16	22	32	45	64
ohms	1400	1300	1200	1000	800	600	400	200	100	?	?

Table 6

I cannot get the last two values and by the way some lenses don't show very precise values, that because the way the system has been adapted to them. I.e. Zenzanon PS50 /3.5 at F22 reports 300 ohms but this value means an aperture between F16 and F22, that happens because the lens has only 12 stops instead of 13 and on the new style shutter PCB it isn't possible to change the single resistor.

Position			1	2	3	4	5	6	7	8	9	10	11	12	13
PS 35/3.5	3.5	22	X	3.5	4		5.6		8		11		16		22
PS 40/4	4	22	X	X	4		5.6		8		11		16		22
PS 50/3.5	3.5	22	X	3.5	4		5.6		8		11		16		22
PS 65/4	4	22	X	X	4		5.6		8		11		16		22
PS 80/2.8	2.8	22	2.8		4		5.6		8		11		16		22
PS 110/4	4	32	4		5.6		8		11		16		22		32
PS 135/4	4	32	4		5.6		8		11		16		22		32
PS 150/4	4	32	4		5.6		8		11		16		22		32
PS 180/4.5	4.5	32	X	4.5	5.6		8		11		16		22		32
PS 200/4.5	4.5	32	X	4.5	5.6		8		11		16		22		32
PS 250/5.5	5.6	45	5.6		8		11		16		22		32		45

Table 7 X means this position doesn't exist.

On the table 7 is summarized the possible aperture values for the usual new style Zenzanon PS lenses, to be noticed only 5 of them have the whole 13 positions.

Final notes

Seiko #0 shutter is a valuable piece of clockwork engineering although it has its own quirks: It was projected in order to last in the time, less to be serviceable. For example, on excellence side, every lever is bush mounted, and the slotted disk (A on PIC 1) turns on a special bearing done by balls and cuprum segments in order to get lightness and elasticity (see PIC 45). On the other hand, the cover of shutter chamber (see PIC 9) is hold by the four screws fixing the shutter body cup to the base plate, causing the shutter blades falls all around when the shutter cup is removed, furthermore there are some springs grounded to the internal side of shutter cup, that doesn't help the reassembly.



PIC 45: Balls-segments bearing.

Zenza Bronica, Zenzanon is a trademark of Tamron Industries; Seiko is a trademark of Seiko Corporation

Disclaimer

I'm not responsible for any error, omission and/or inaccuracy in this document. I'm not associated with any company or site mentioned on this document. I'm not associated with any service center. I've not access to any official technical literature, every information on this document has been collected examining the equipment or from the Internet when mentioned. I'm not a service professional nor perform any service activity so please don't ask me to do any kind of service.

Afterwords

You're welcome to submit comments or information if you'd like to share ideas with other people. This document could be copied and published but citing the source. Feel free to link this document. My email address is max@buonaluce.com

Appendix A
Rear side mechanisms time diagrams

Cocking phase time diagram

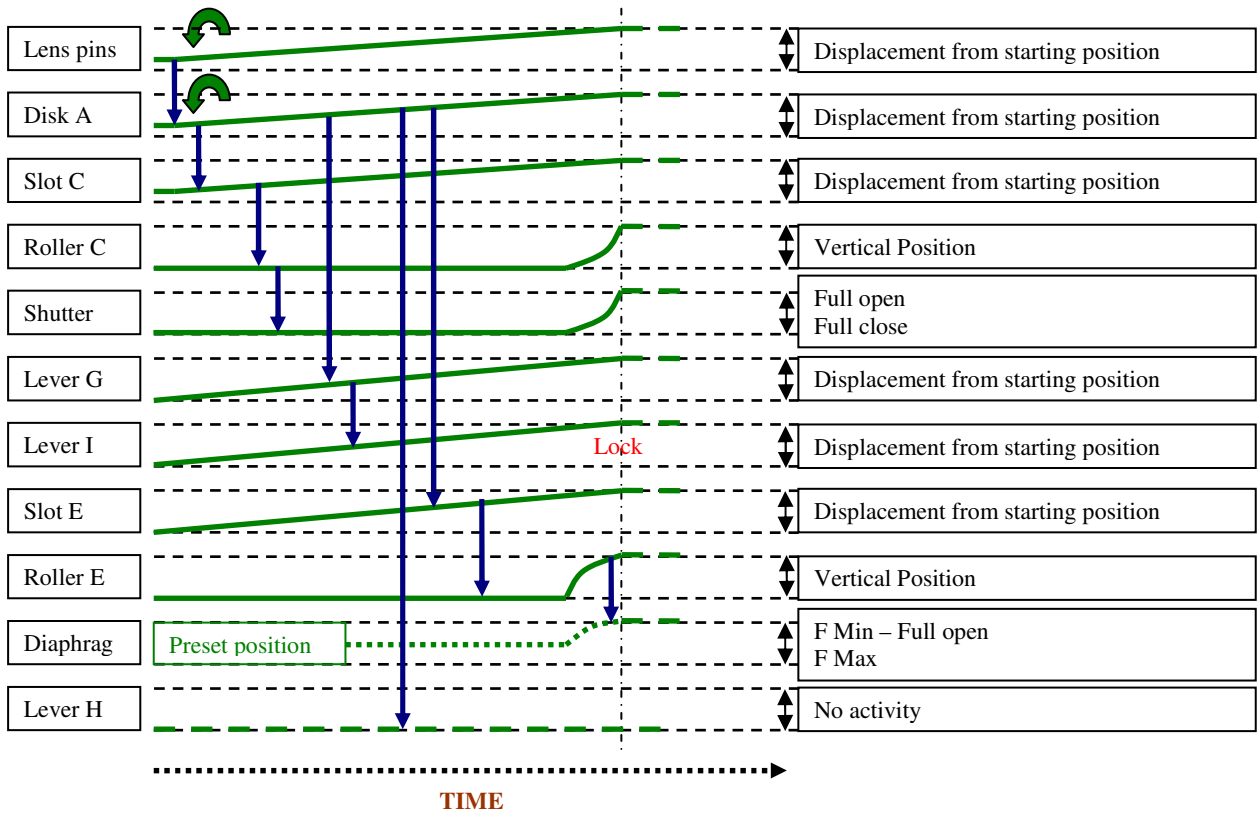

Shooting phase time diagram

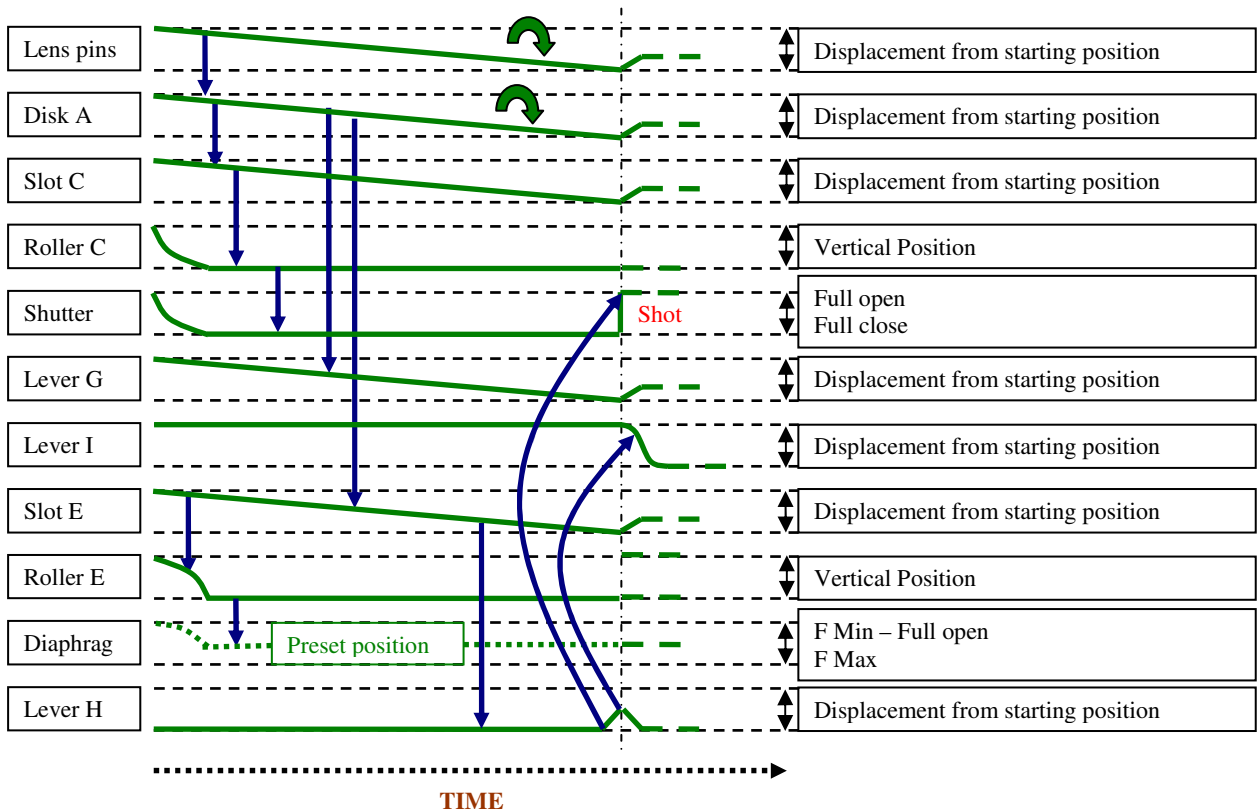

Appendix B

Lens pin diagram

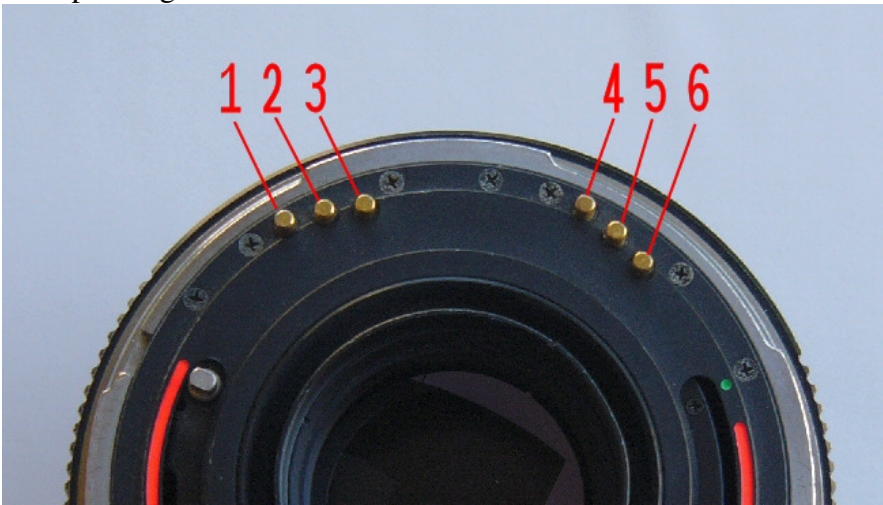

Pin	Shutter wire color	Use
1	Black	Ground, common lead
2	Green	Flash contact
3	Yellow	A/T Switch sense
4	Blue	Electromagnet sense
5	Orange	Magnet (Electromagnet) solenoid
6	White	Diaphragm value

© Buonaluce.com 2008