

# Seagull 4A TLR (1964 Chinese Made) Restoration Project Part 1 - Lens & Front Plate Removal -

By Orland Punzalan

DISCLAIMER: I'm not an expert and I'm still learning as I worked on and during the course of repair.  
I documented the whole process including my mistakes so others can learn and avoid them.  
This is my personal opinion and procedure and serves as a visual repair guide only.



Camera in photo  
after CLA is done.

## TOOLS AND MATERIALS NEEDED:

- Flathead screwdriver
- artist's spatula or thin scraper
- cutting knife or x-acto knife
- lens rubber remover
- lens spanner wrench or pinhead pliers
- alcohol
- some tools you might need to fabricate



**01:** Remove the front (viewing/taking) lens elements. I used a furniture rubber feet that matches the retaining ring size of each lenses. When it's not budging put drop of alcohol all around the edges of the ring and wait a few minutes. Make sure to wipe of excess so not to damage markings. Set aside lenses.



**02:** inspect the front lens elements front and back side. I make it a point to immediately clean it with glass cleaner using cotton buds and then wiping it off with a clean lens tissue. The set aside.



**03:** I removed the viewing lens elements and in turn they all come apart (pictured) be sure to remember where each once goes. It is very IMPORTANT. I made the mistake of putting back the middle lens (highlighted HL, in yellow) the WRONG way and the focus is off once assembled.



**04:** I realised during the process that you can skip removing the viewing lens prior to removing the front plate. See the screw (HL in yellow). That is the focusing stop screw for the viewing lens group. REMEMBER this, as this is part of the focusing procedure during assembly. Otherwise leave it as is and don't touch it.



**05:** If you decide to do this part then loosen but don't remove the screw. Just enough so you can rotate the lens unit counterclockwise.



**06:** Remove leather on each side carefully. Sometimes you might need to use alcohol to loosen the glue. But in this case I inserted a thin artist spatula and work my way underneath to remove the leather. NOTE: some camera has brittle leather so remove at own risk. Store the leather inside book pages to flatten while working on the camera.



**07:** Once lenses and leather are out study the front plate. There are four flathead screws on each sides (HL in yellow) remove them. It pays to note which screws belongs to which sides. Unscrew the shutter button retaining ring (HL in red) on lower left using lens spanner or pinhead pliers.

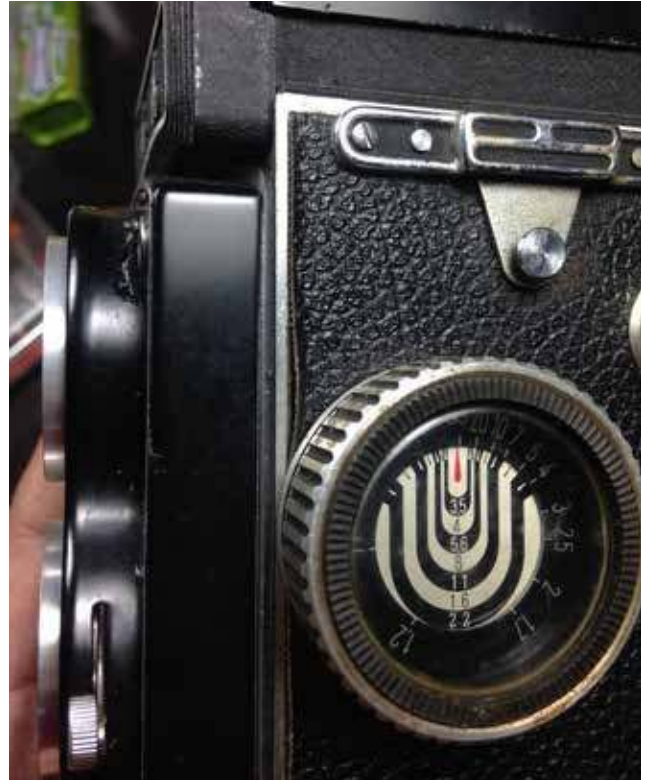

**08:** Before removing the front plate, make sure you make notes of the distance, speed and aperture setting. Ideally put the speed to B, aperture to the widest opening (3.5) and distance scale to infinity.

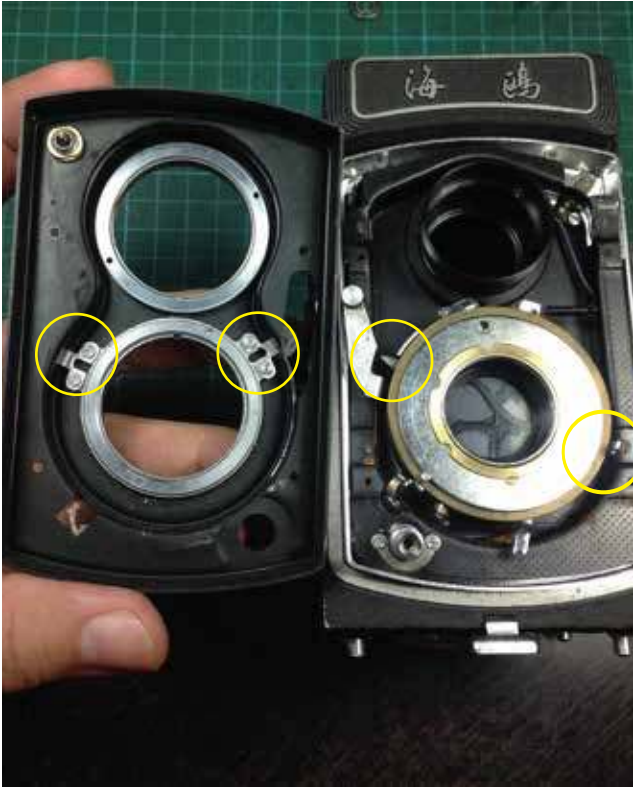

**09:** Wiggle the plate side to side and make sure to work your way out passing the cocking and self timer lever. Watch out for some screw washers that might fall off and be sure to mark where they belong. Take note where the speed and aperture selector are position against the front plate (HL in yellow).



**10:** Do note there is a hard plastic part just below the cocking lever. It is necessary to place it back once you glue back the leather.



**11:** The interior side where you can see the plastic part covering the cocking lever side.

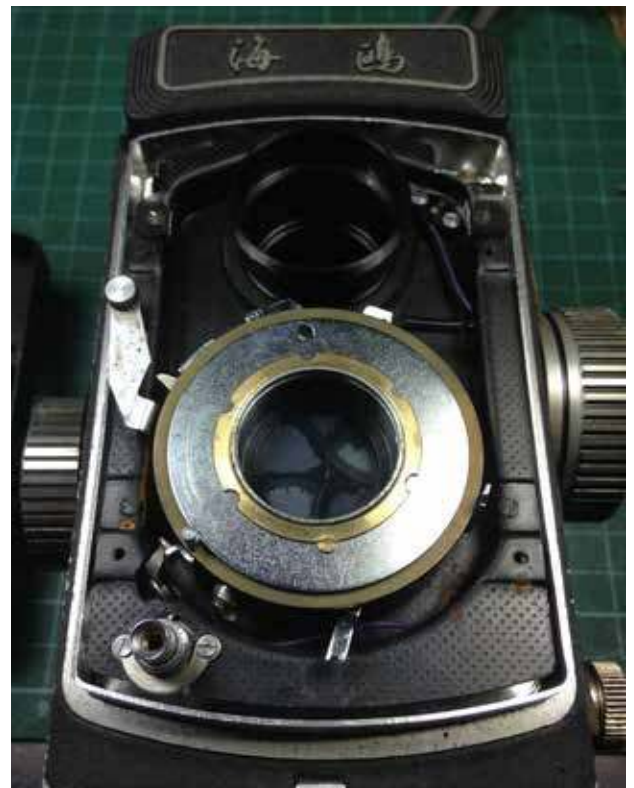

**12:** Now study the inner front plate and plan your way for the next stage.

# Seagull 4A TLR (1964 Chinese Made) Restoration Project Part 2a - Shutter CLA (upper mechanism) -

By Orland Punzalan

DISCLAIMER: I'm not an expert and I'm still learning as I worked on and during the course of repair.  
I documented the whole process including my mistakes so others can learn and avoid them.  
This is my personal opinion and procedure and serves as a visual repair guide only.



**NOTE:** Prior to this I have experienced working on Compur, MXV and Prontor shutters on some of my cameras. And before I started working on this TLR I knew the main unit is not functioning, shutter stuck but mostly complete body parts. I got it cheap so this is a good camera to work on and hoping I can revive it? I sourced another unit (see above right) that is not complete and knowing the shutter is somewhat working. It helps that they are the same exact model. In this project, my aim is for 2 units to make one working camera.

## TOOLS AND MATERIALS NEEDED:

- Watchmakers screwdriver set
- tweezers
- cotton buds / tissue / cotton rags
- lens spanner wrench or pinhead pliers
- Lighter fluid & alcohol
- Air blower
- small steel brush for rust scraping
- small bristle brush for cleaning
- dremel rotary tool (optional)
- glass jar
- small bottle cap / container
- some tools you might need to fabricate

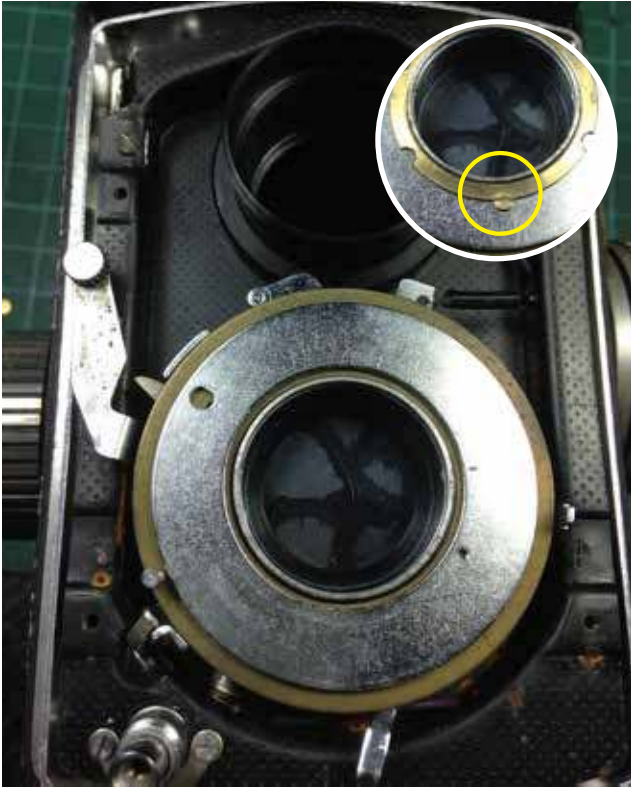

**01:** Unscrew the small screw (Highlighted HL in yellow) in inset photo. Do note when putting it back DO NOT over-tighten. And remove the cover plate retaining ring using only your fingers. If its too tight use the lens spanner. Be gentle as the materials are thin metal.



**02:** Once the cover plate is removed, study the speed plate position. At this stage you can test how it moves while holding it down.



**03:** Remove the speed plate and then you can now see the internal parts of the shutter mechanism. Study them and do a visual inspection of the parts. Overall oily, dirty and some rust here and there. HL in blue is the missing knob for the Self Timer (ST) lever.



**04:** I noticed one missing screw (HL in yellow) for the ST mechanism. The one HL in red is the spring that holds back the ST lever to its starting position. You can detached it for removal. After inspection the ST on this one works but the Slow Speed Escapement (SSE) on right does not.



**05:** Remove the ST mechanism. See the HL in red remove the flash sync post. Be careful as the screw is tiny. Once cable is out placed the screw back. The HL in yellow on top is the spring that holds back in position the cocking lever, detached them and make sure it wont fly out.



**06:** Inspect the ST escapement mechanism. Make sure it works. This one has some rust spots and needs light scraping. Do note where the spring was placed. You might need to de-rust this parts using whatever available means you can. I have a dremel so it helps.



**07:** At this stage I decided to detached the whole shutter assembly from the body. Start by removing the back lens group using lens spanner HL in red. Afterwards you can remove the retaining ring HL in yellow. Do note that at horizontal position the notch is touching the interior sides. Be careful turning it counterclockwise while holding the lens spanner as this might slip.



**08:** After removal of shutter inspect the position of the levers from the back side. For both the aperture and speed levers.



**09:** The front base plate of the focus rails now is shown. With rusts all around. Time to use my dremel to good use and then touch up with paint. Note the loose spring HL in yellow I used cell tape to keep it. And the sync cable HL in red.



**10:** The sync cable post on the shutter side HL in red. Note the back side position of the cocking lever and aperture selector. You'll remove it later if you decide to dig deep.



**11:** Now proceed to remove the SSE mechanism by removing two screws. Note that one screw is longer than the other HL in red. Take note of the position where it goes back. It is important as minute increment to left and right affects the speed. What I did is to mark the base metal and inscribed with pointed tool.



**12:** Now the big mechanism is gone you can see the smaller lever and pivoting parts on top. I HL the position here of the mechanism. This is where you can test of the blades by moving the lever points HL in blue. If yes, it is a good sign and it just needs cleaning up. Mine is stucked up so I must proceed further than this stage here.



**13:** I put both the ST and SSE mechanism in a lighter fluid or ronsonol bath. I use a bristle brush to wipe it while submerged. You can do this several times while taking it out for a test run on all their gears. I did it thrice each time with a fresh fluid batch.



**14:** Now pardon my terminology on these section. Start with this lever. Do note that this is in sequence for easy removal. Loosen the big screw HL in yellow and take note of the spring below. Mark its position.



**15:** Once the first lever is out HL in yellow proceed with the cocking lever HL in red. This is where a big problem appears on this unit.



**16:** As you can see there is no spring underneath HL in red. See inset photo of a Prontor lever with spring as reference. Maybe the previous owner or repairman tried and failed in putting this back together. Reason why many missing parts. Now this is where the second donor unit comes into play. Without the donor unit this build is a bust. See NOTES section at last page.



**17:** Now to carry on with the build, assuming we have the spring for the cocking lever. See different views of the lever.



**18:** Next to be removed is the shutter release lever. Loosen the screw HL in yellow.



**19:** Once again note the spring HL in yellow of the shutter release lever. Take note of its position in relation to the shutter housing.



**20:** Afterwards work on this actuating lever HL in yellow. This activates the shutter blades once released. It's rusty so might need to scrape using wire brush.



**21:** Remove the screw and take note of the spring position.



**22:** At this stage all of the upper parts of the shutter are removed except this one HL in yellow. This is the return spring once the shutter is activated. It makes the blades return to its closed position.



**23:** I placed all the parts in a bottle cap after I cleaned them one by one. I make it a practice to clean them immediately after they are removed. This is a good time to check for some bent or mis-aligned levers.



**24:** Now this is where we separate the men from the boys. If you want to proceed working on the shutter and aperture blades you can carry on Part 2b. Otherwise just proceed to clean the blades on both side of the shutter with lighter fluid while flushing the dirts and grimes. I used brush and blower. This might be tricky as you'll never know whats the condition of the internal parts?



**NOTE:** And thankfully with the donor unit on the right, which is an exact shutter I can just easily swap with working shutter in its place. But for the purpose of this build, I will carry on and finish the procedures.



**NOTE:** The donor unit with the original cocking lever spring.



**NOTE:** Other view of the cocking lever spring in working condition.

**25:** If at this point you consider the job done then proceed from this point onwards to do everything in reverse. Make sure when you placed each parts back in place to test how it works? Be sure it does its job otherwise you will re-do them again if you missed one item. Don't ask why as it happened to me? Congrats!

# Seagull 4A TLR (1964 Chinese Made) Restoration Project Part 2b - Shutter CLA (shutter & aperture blades) -

By Orland Punzalan

DISCLAIMER: I'm not an expert and I'm still learning as I worked on and during the course of repair.  
I documented the whole process including my mistakes so others can learn and avoid them.  
This is my personal opinion and procedure and serves as a visual repair guide only.



**NOTE:** Previously on Part 1a I did mention once the upper part mechanism has been dis-assembled and cleaned, you can just proceed to flush clean the blades without further dis-assembly. And put them back once done. But if you're still here, it means you're brave enough to carry on a more delicate procedures. So lets go!

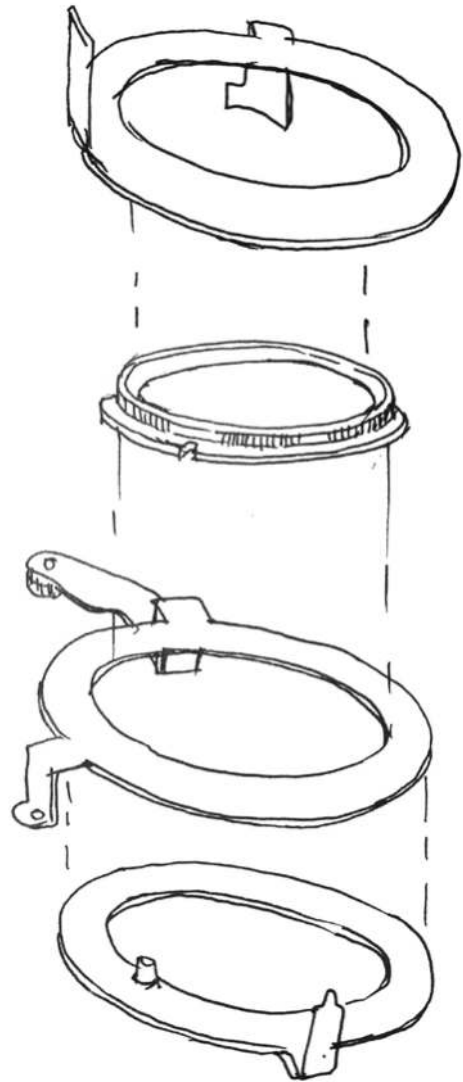

**NOTE:** I did not take photos of this parts. So I did a sketch from memory how it goes in sequence. The diagram is not accurate, just for illustration purposes. Just remember before removing them to keep note how they work and where they go.

## TOOLS AND MATERIALS NEEDED:

- Watchmakers screwdriver set
- tweezer / toothpick
- cotton buds / tissue / cotton rags
- lens spanner wrench or pinhead pliers
- Lighter fluid & alcohol
- Air blower
- small steel brush for rust scraping
- small bristle brush for cleaning
- dremel rotary tool (optional)
- glass jar
- small bottle cap / container
- some tools you might need to fabricate



**01:** Back side of the shutter body has three screws HL in yellow. Remove them take note of the position which screws goes to which hole.



**02:** Once removed you can wiggle the whole upper part and take note how it goes back. Clean it and set aside.



**03:** Take out this plate. This is the assembly that open and closes the shutter blades. Take note of those HL in blue that holds it down to the metal plate. At this point before removing, try to see how the pivot points rotate. The Stainless Steel (SS) ring rotates as you move the pin on both sides.

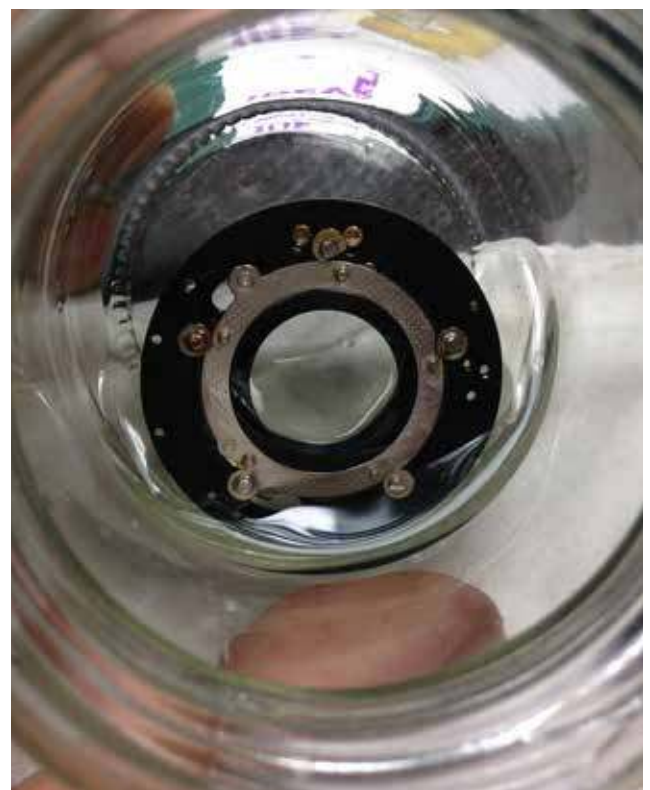

**04:** Before I did the disassembly I dip it on lighter fluid bath and brush/wipe it clean. Take it out once done and make sure to wipe dry.



**05:** I made some sketches of those washer and screws where it must go back. Once the SS ring is out I can see further cleaning is necessary as the underside is rusted on the pivot points. Make sure to de-rust and clean all parts during this stage using combination of alcohol/ronsonol or even mineral spirits if you have. Pay attention to the rusted areas and use small wire brush.



**06:** Next is the actual shutter blades. Study the position and take them out and clean them using the lighter fluid bath method. After the wash take it out and proceed to wipe them dry. I used cotton buds & wipe them blades gently. Do it on a flat surface. Once done set aside and try to rotate from the back side the aperture blades to see how they work? And proceed to remove the 3 screws HL in yellow.

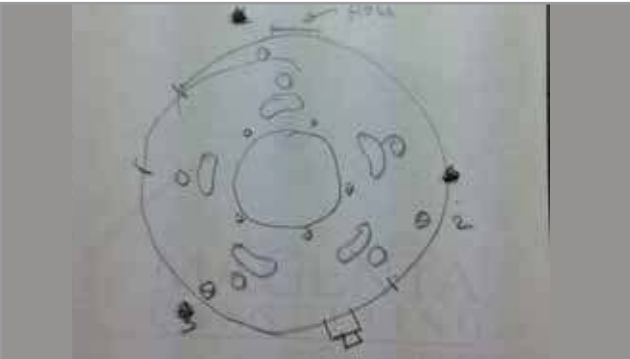

**07:** Once again I did a sketch of which screws goes to where as guides. And then separate the plate cover from the aperture blades. The blades are dirty and oily it stuck to the metal. You can see at this point how dirty and grimy the whole internal parts of the blades. This is the reason with sticky blades.



**08:** The close up shots of the aperture blades. This is the most tricky part of the whole procedure so take your time here. You might be doing this in several tries before getting it right. But don't worry it can only go one way so be patient. Proceed with the fluid bath and dry clean them and once confident that they are ready you can proceed with the re-assembly on the next stage.



**09:** Before the re-assembly make sure this two metal parts are also cleaned and dry. Blow dry them if necessary. And once you're confident that all are nice and cleaned you can proceed with the re-assembly of the aperture blades.



**10:** Now do the re-assembly of the blades take note of those pivots points HL in yellow & red. And the HL in blue where the pivot RED goes. I used a furniture rubber as a base to elevate the plate. Start with one point and do them one after the other. I did it counterclockwise. There are five blades and the first 3 should be easy.



**11:** Once you get to blade #4 & #5 it gets trickier. Because you need to make sure that #4 & #5 goes below number 1. As you can see, the blades here are flipped. This is my first attempt and after trying to put it back it doesn't open & closed. So I re-started. Do note never touch them with your bare fingers. If you did, wipe them with fluid. Use tweezers or toothpick to move blades around.



**12:** So study procedure #10 again and take note of the HL parts. So here we are this time I numbered them accordingly. Start with #1 from the bottom and work your way counterclockwise.. Once you're at #4 pay attention on how to put it underneath #1. And the same with #5. See end result here.



**NOTE:** Prior to procedures #10-12, I practiced putting the plates back in the shutter body without the blades. This way once everything is in order and ready to put back, I already knew which position it goes back.



**13:** Once the aperture blades are placed, put back the metal plate back on top. This is also tricky and might give you several tries to position them as you can see, the pivot point slides in place. Once you managed, try to rotate them and see how if it works. If it does you are almost done. This is the last stage of the shutter CLA. After this its all re-assembly.



**14:** Here is where all the procedures matters. From this point onwards do everything in reverse. Make sure when you placed each parts back in place to test how it works? Be sure it does its job otherwise you will re-do them again if you missed one item. Don't ask why as it happened to me? Photo shows how it should look once done. Congrats!

# Seagull 4A TLR (1964 Chinese Made) Restoration Project Part 3 - Viewfinder (WLF) & Mirror Cleaning -

By Orland Punzalan

DISCLAIMER: I'm not an expert and I'm still learning as I worked on and during the course of repair.  
I documented the whole process including my mistakes so others can learn and avoid them.  
This is my personal opinion and procedure and serves as a visual repair guide only.

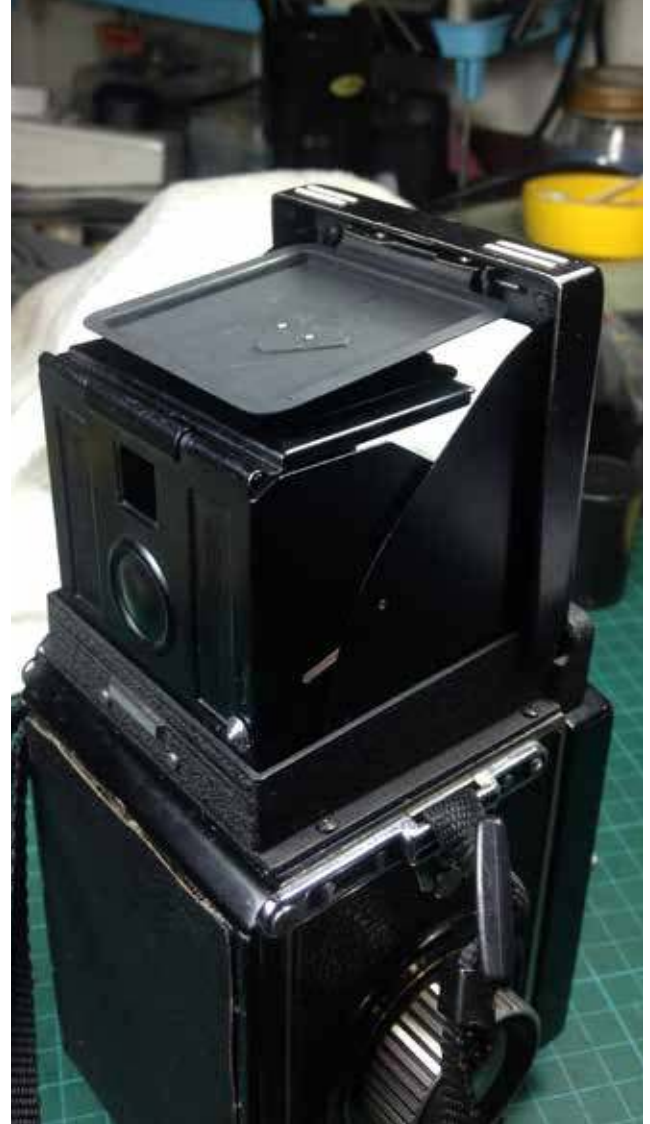

**NOTE:** Nothing makes the experience of using TLR than looking at waist level viewfinder. If this parts are cloudy and dusty it will effect your user experience. If you're lucky all you need to do is cleaned the outer parts, glass, magnifyer etc and no need to remove the viewfinder assembly from the body. Just cleaned them with baby wipes towels. But if needed proceed with the tutorials. Do note that this section requires careful handling of thin and delicate mirrors. Dont ask why? I have broken one already.

## TOOLS AND MATERIALS NEEDED:

- Watchmakers screwdriver set
- tweezer / toothpick
- cotton buds / tissue / cotton rags
- Baby wipes / lens cleaner / liquid soap / alcohol
- Air blower
- Black & Silver touch up paint / pen markers
- Steel wire brush
- Latex gloves



**01:** Start by removing 4 screws HL in yellow, 2 on each side. As always try to note how the parts work and where it goes prior to removal.



**02:** Here you can see the angled mirror that allows you to see through the taking lens. Inspect the internal parts for obvious dust and dirt. Watch out for rusted metal parts as well.



**03:** If your mirror is like this then you're in luck. It only needs light cleaning. Start with air blower on all corners. I do this upside down so dust will fall off. Then follow it up with light brushing (use soft brush). If in case there are stubborn dirt on mirror use cotton bud dip in lens cleaner or alcohol. Never touch the front mirror surface with your bare fingers. If you can use latex gloves.



**04:** Do it gently as this is a front surface mirror and the reflective part can be easily scratched. Test on edges first before going through other portions. There is really not much you can do here if you cant remove the stains. Replacement mirror is your options. In which case all you need to do is remove two screws on the side HL in yellow and replace the mirror.

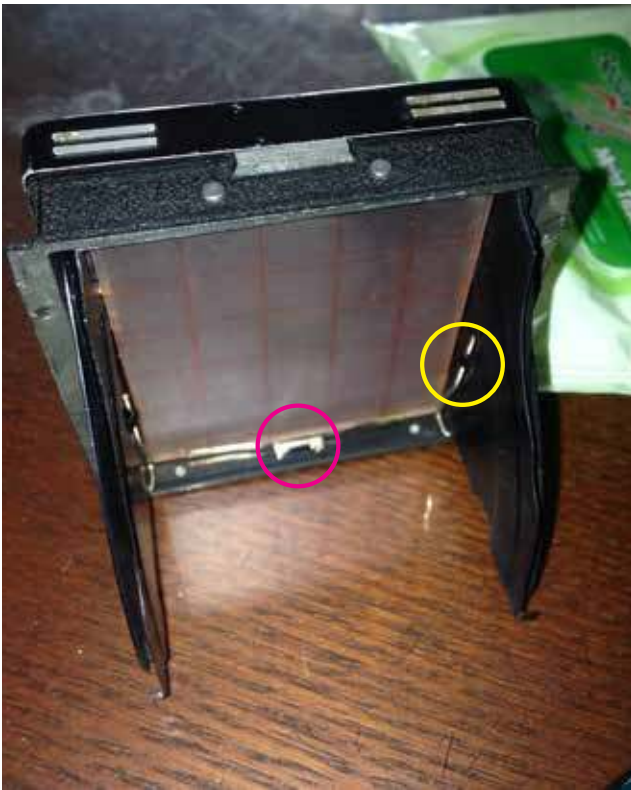

**05:** Once mirror is done, work on the ground glass viewer. Look on the underside and you can see on both sides HL in yellow 2 metal clips that act as return spring for the cover. Take note of the glass retaining clip on front & back side HL in red.



**06:** Unhook them from the latch as shown HL in yellow



**07:** Push down this metal clip and slide outward to remove. Be gentle as the glass is thin (around 1.2mm see insert). Take note of rusted metal parts. In this case you need to scrape and touch up with black & silver paint accordingly. Take out the mirror.



**08:** Once mirror is out you need to clean them. I did wash it first using water & dishwashing liquid soap. I dried and did one more lens cleaning wipe for good measure. If all cleaned, its time to put them all back in reverse order.

# Seagull 4A TLR (1964 Chinese Made) Restoration Project Part 4 - Lens Focus Adjustment -

By Orland Punzalan

DISCLAIMER: I'm not an expert and I'm still learning as I worked on and during the course of repair.  
I documented the whole process including my mistakes so others can learn and avoid them.  
This is my personal opinion and procedure and serves as a visual repair guide only.

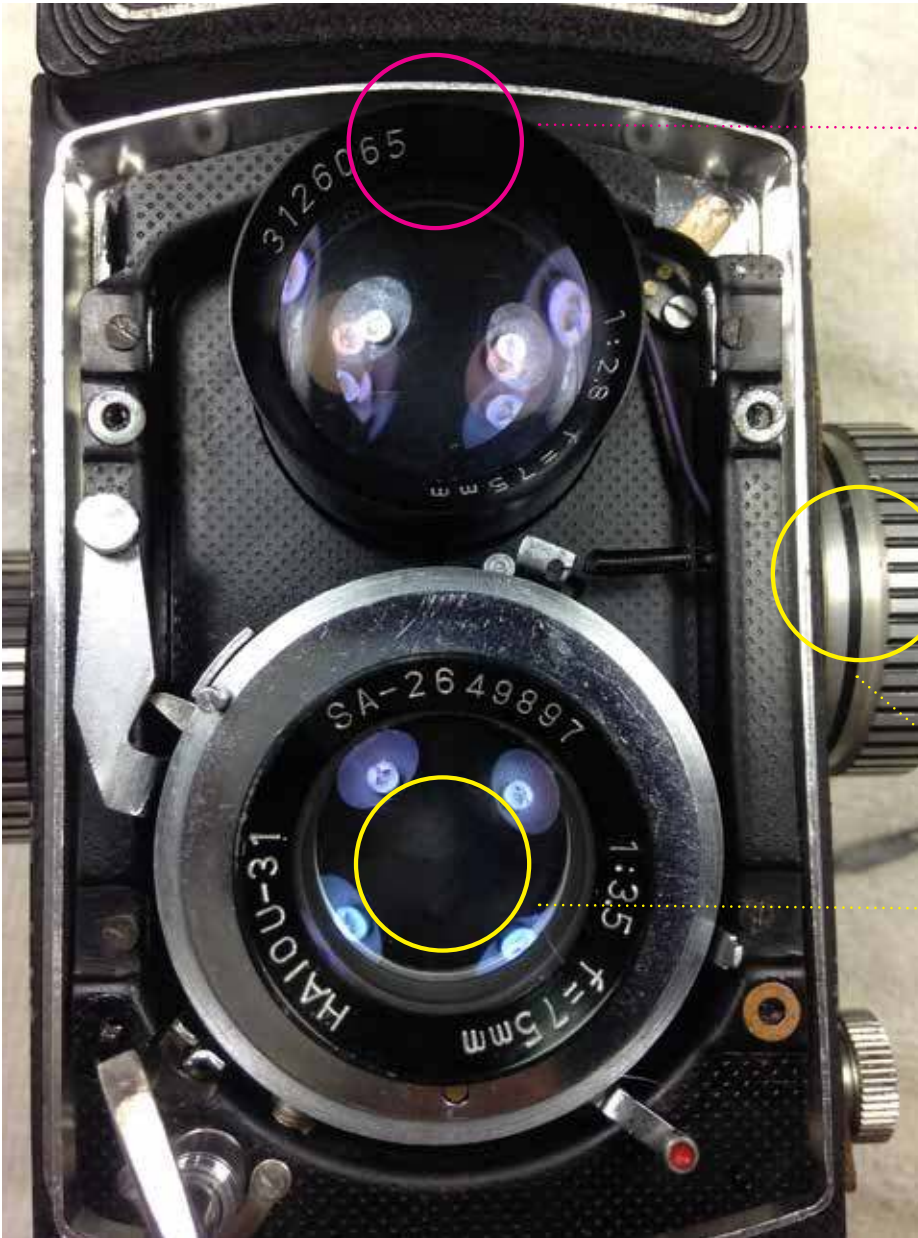

## **VIEWING LENS ADJUSTMENT:**

This has screw stop for you to be able to adjust the viewing lens accordingly.

## **TAKING LENS ADJUSTMENT:**

Do this first. The taking lens and focus or distance scale knob on the side, HL in yellow, are the key to making sure its in focus.

**NOTE:** Now that the shutter and the lens are put back, the next important thing to do next is make sure the focus is correct for both the taking and viewing lenses.

## **TOOLS AND MATERIALS NEEDED:**

- Watchmakers screwdriver set
- tweezer / toothpick
- cotton buds / tissue / cotton rags
- lens spanner wrench
- Acetone & alcohol
- Air blower
- some tools you might need to fabricate
- Using big flat screwdriver (see step #7)
- Gound glass
- cell tape



**01:** Start with removal of this plastic retaining ring. Use a good rubber grip if not use the flatside of your lens spanner. Be careful as you might slip and dent the plastic grooves.



**02:** Take out the plastic dome. If it doesn't fall off by itself use a cell tape to grab it.



**03:** Take out the next plastic spacer and you will see this glue residue underneath. I used cotton bud dipped in acetone to wipe it off. Avoid touching the printed scales.



**04:** Use a lens spanner counterclockwise to remove the ring for the scale. Afterwards you will see there is some sort of metal bent clip (x3) around the scale. No need to straighten them, scale can be taken out easily.



**05:** Here are the parts numbered in order of removal. Clean them and set aside.



**06:** This where you need a bit of ingenuity, the middle part with a slotted center HL in yellow, you need to loosen. Take note of the position of the slot in the knob HL in red. This is your guide for the infinity mark.

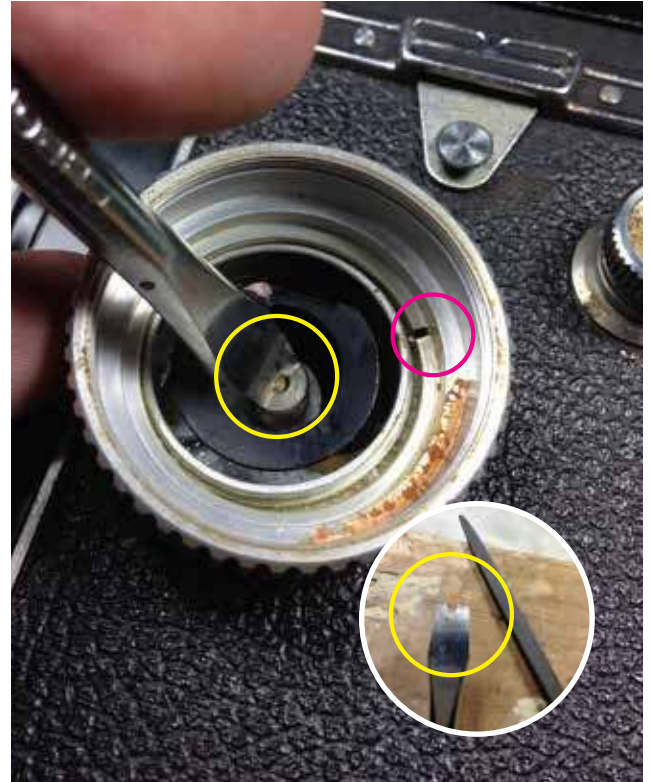

**07:** Since I wanted to do this fabrication before, this is the best time for me to do one (see inset photo). Just use a small file and by trial and error you can make one that fits the slot snugly. If you dont have one, a big screwdriver will do just fine as well.



**08:** Rotate the knob left or right to see how it goes. This make the focus rail move up and down. Do this and do step #15 afterwards. Each time you adjust accordingly to set focus properly.



**09:** While doing this you can then remove the big knob and reposition it later for for the appropriate scale.



**10:** This section is to show how you go about doing ground glass focusing at the back of taking lens. Start by loosening the screw HL in yellow to remove the back cover plate.



**11:** You might need to do the other side if needed. Remove and set aside.

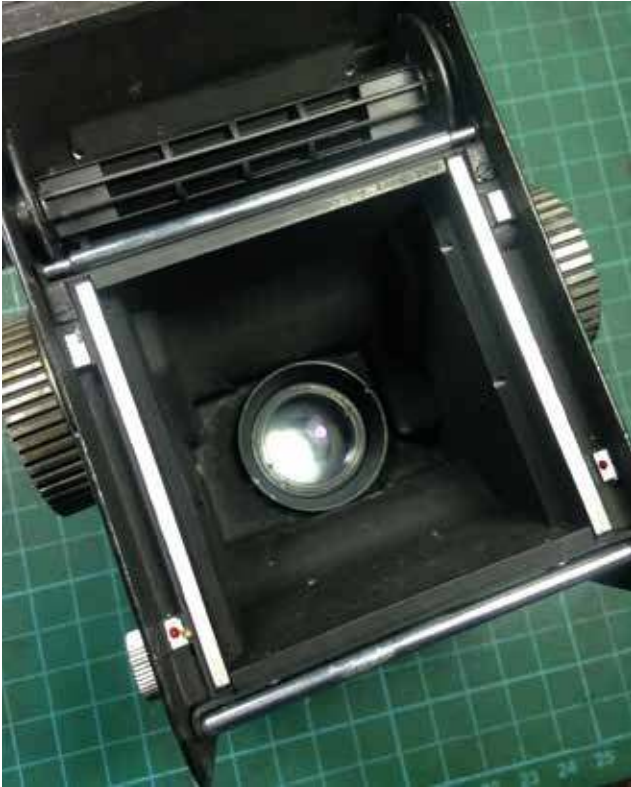

**12:** This is the view from inside of the taking lens. We assumed that all lenses at this stage are cleaned and properly placed.

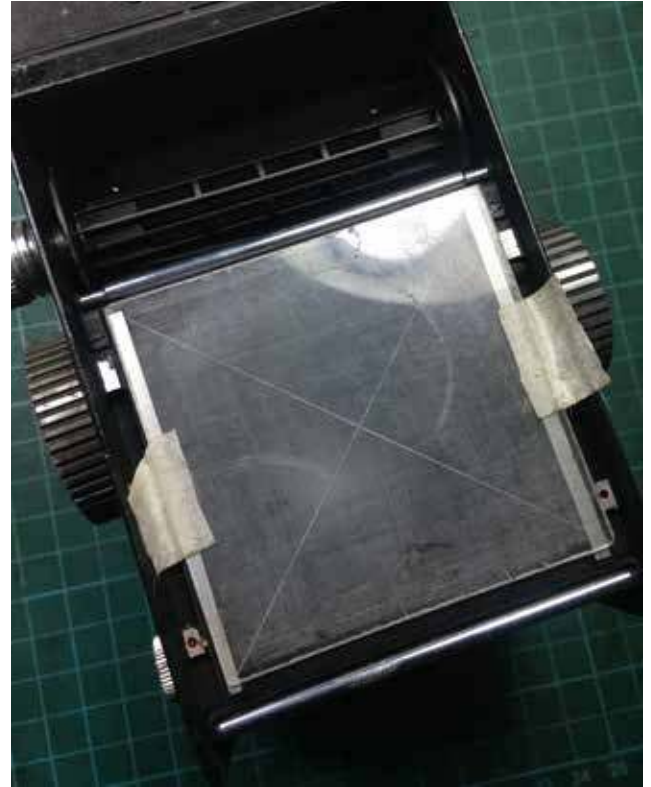

**13:** Put a ground glass or a clear plastic with frosted tape on the other side. Do note that the frosted or matted portion of the glass should be inside facing the lens. Tape it on both sides and make sure it lays flat on film plane.



**14:** Use a magnifying loupe or similar to view the ground glass. What you need to set on the shutter is put it on B setting, the widest opening (f3.5) and trip the shutter and hold it either by putting cell tape or using shutter release with lock.



**15:** Since without the back plate there is no more tripod mount, I just handheld and with a bit of dexterity try to view from a distance and see if the view is sharp. This part is trial & error and might take you several tries before getting the focus right. See and do step #8 after each viewing.



**16:** Once you hit the perfect focus mark the slot as mentioned HL in red and now it is set to infinity. You can now tightened back the slotted screw and make sure it is secured without moving the knob.



**17:** Moving on to the viewing lens, there is a stop screw HL in yellow above the lens assembly. Loosen it without removing it, just enough so the lens can be rotated either left or right.



**18:** Now open the viewfinder and hold the lens with your right hand try to adjust the lens position. Do this slowly in small increments, once you hit the focus sharp on viewfinder you're almost done.



**19:** Use the magnifier to view it up close and make sure the infinity is sharp and double check the taking lens as well if the infinity is in focus. If both are correct try to view it in close focus too. Usually it is right but if necessary you might need to compensate a bit to have the best focus spots for both infinity and close focus. Afterwards, tighten everything and put all back in reversed order. Congrats!