

**The
Synchro-
Compur
00-
MXV
Wide-Reflex**

Emi

CONTENTS

THE SYNCHRO-COMPUR 00-MXV WIDE-REFLEX

FEATURES OF THE WIDE-REFLEX	1
DISASSEMBLY OF THE WIDE-REFLEX SHUTTER	16
DISASSEMBLY OF THE LIGHT VALUE MECHANISM	29
REASSEMBLY OF THE LIGHT VALUE MECHANISM	37

© Copyright 1972

NATIONAL CAMERA
TECHNICAL TRAINING DIVISION

ALL RIGHTS RESERVED

1113

CONTENTS

THE SYNCHRO-COMPUR 00-MXV WIDE-REFLEX

1 FEATURES OF THE WIDE-REFLEX
16 MECHANISM OF THE WIDE-REFLEX SHUTTER
23 MECHANISM OF THE LIGHT VALUE MECHANISM
37 MECHANISM OF THE LIGHT VALUE MECHANISM

written and illustrated by
Larry Lyells

© Copyright 1972

NATIONAL CAMERA
TECHNICAL TRAINING DIVISION

ALL RIGHTS RESERVED

THE SYNCHRO-COMPUR 00-MXV WIDE-REFLEX

FEATURES OF THE WIDE-REFLEX

The Synchro-Compur 00-MXV is manufactured in several models to fit the requirements of different cameras. In addition, many special shutters are designed exclusively for individual camera makers. Although the MXV models vary in certain respects, they are basically the same in operation.

You have already studied the externally set and released Synchro-Compur 00-MXV. This shutter is shown in (A) of figure 1. In (B) of this figure, notice the modifications which have been made to allow the same shutter to be set and released by the camera controls. Except for the slight differences in the cocking ring and the outer release lever, the two shutters are practically identical. Also, there is a variation in the flash terminal strips—in cameras using the internally set and released model (B), the flash sync nipple is located on the camera body rather than on the shutter housing.

A

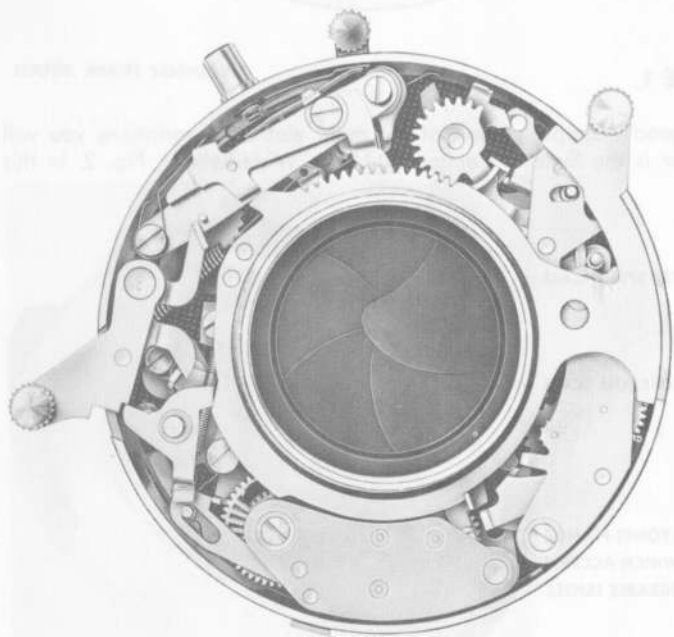

COURTESY FRIEDR. DECKEL

B

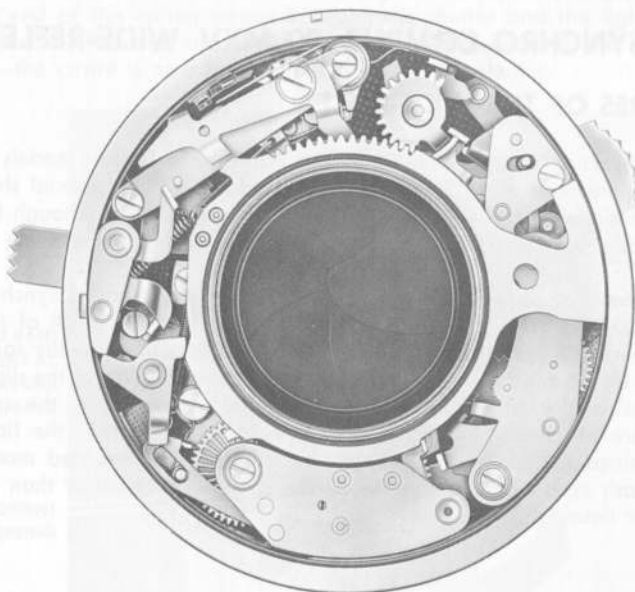

FIGURE 1

COURTESY FRIEDR. DECKEL

A good example of one of the more elaborate variations you will encounter is the Synchro-Compur 00-MXV "Wide-Reflex," Fig. 2. In this

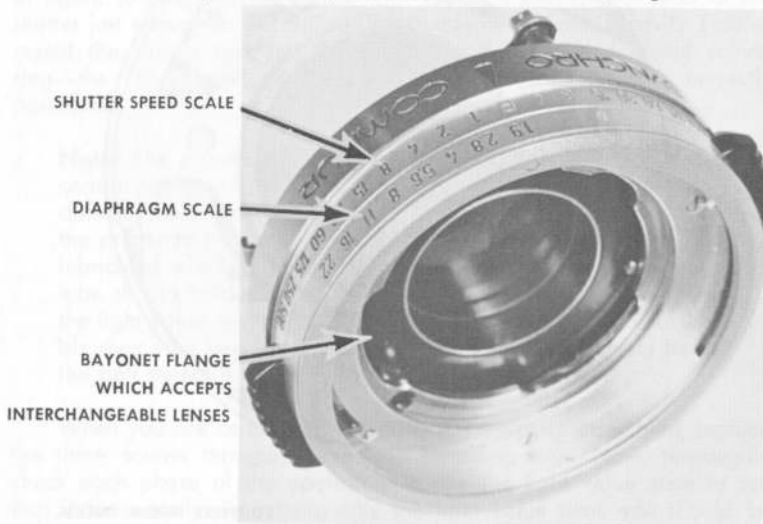

FIGURE 2

shutter, the basic design has been modified for use on a single-lens-reflex camera with interchangeable lenses and a cross-coupled exposure meter. To accommodate such a camera, the Wide-Reflex is a behind-the-lens, programmed shutter which is set and released by the camera film advance mechanism. A light value "computer" and a mechanism to open the blades when the shutter is cocked (for through-the-lens viewing) are added to the basic design.

Except for these modifications, the Wide-Reflex is practically the same shutter as the one shown in (A) of figure 1. Thus, there are several comparisons which may be drawn between the two shutters. To distinguish between the two models, the Synchro-Compur 00-MXV you previously examined will be referred to in this text as the "basic 00-MXV." Remember, this is the shutter shown in (A) of figure 1. The model shown in figure 2 and in the following disassembly will be called the "Wide-Reflex."

NOTE: Before taking the Wide-Reflex apart, there are two special tools you may wish to make. The special spanner wrench shown in figure 3 can be made from a piece of tool steel or from a discarded screwdriver. This tool is very handy for removing the notched screws found in many Compur shutters. The other tool, made from a piece of brass rod, is used as a cocking tool when the shutter has been removed from the camera, Fig. 4. The cocking tool prevents damage to the parts when the shutter is manually operated.

FIGURE 3 SPANNER WRENCH

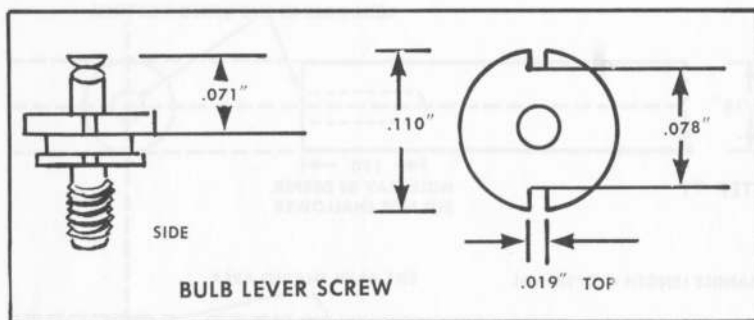

(CONTINUED NEXT PAGE)

(FIGURE 3 — CONTINUED)

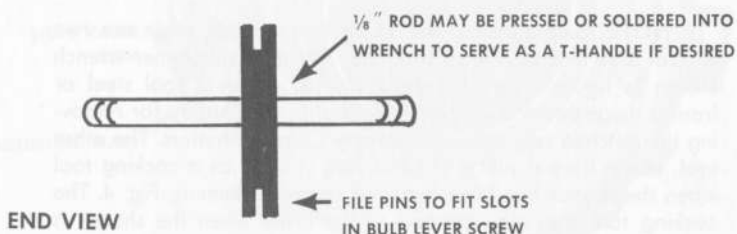
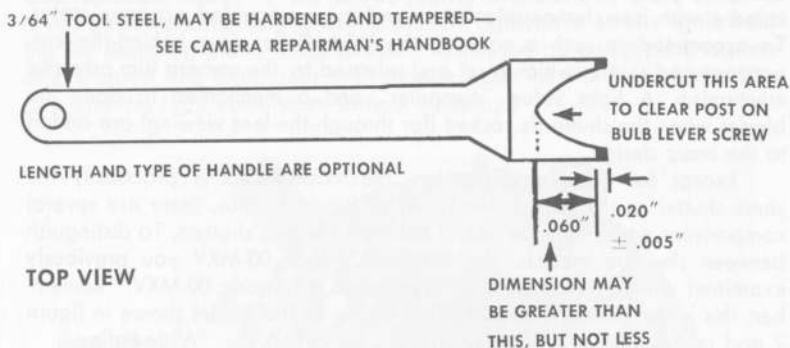
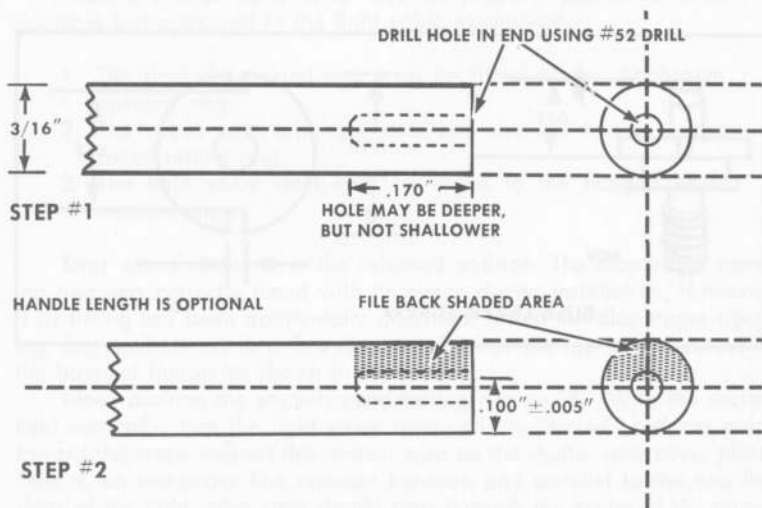
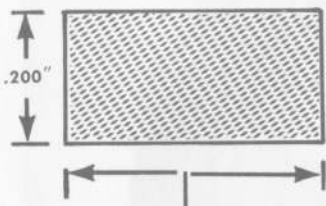
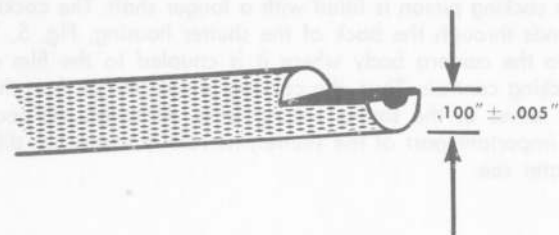

FIGURE 4 SHUTTER COCKING TOOL



(CONTINUED NEXT PAGE)

(FIGURE 4 — CONTINUED)



THIS DIMENSION SHOULD EQUAL THE DEPTH OF THE HOLE DRILLED IN STEP #1

STEP #3

CUT FROM PIECE OF FLAT BRASS .040" THICK

SOFT OR SILVER SOLDER FLAT BRASS PIECE ABOVE HOLE—
FINISH AND POLISH AS DESIRED

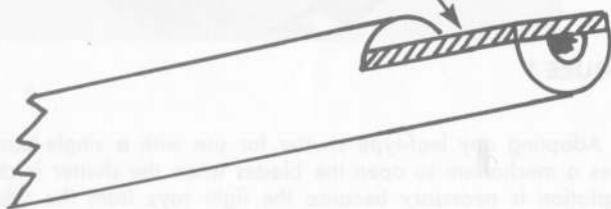

STEP #4

IF YOU WISH, YOU MAY MOUNT AND SOLDER THE SPANNER WRENCH TO THE END OF THE SHUTTER COCKING TOOL, AS SHOWN BELOW. YOU WILL THEN HAVE BOTH TOOLS COMBINED IN ONE HANDLE.

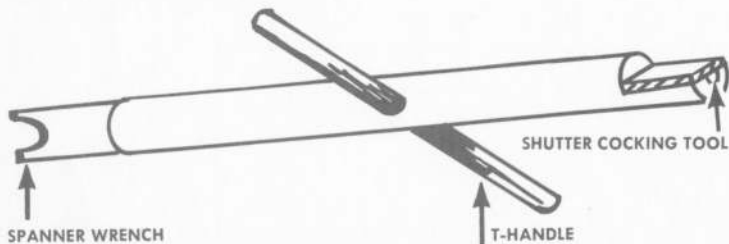

In order to set the Wide-Reflex by the camera film advance mechanism, the cocking pinion is fitted with a longer shaft. The cocking pinion shaft extends through the back of the shutter housing, Fig. 5. This shaft passes into the camera body where it is coupled to the film advance/shutter cocking controls. Thus, the cocking pinion (rather than the cocking ring) now serves as the shutter setting lever. Although the cocking ring is still an important part of the shutter, its role is somewhat different, as you will later see.

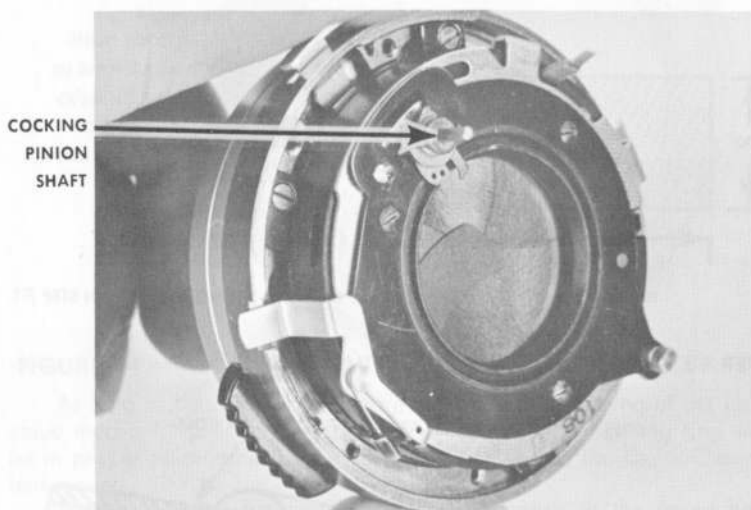

FIGURE 5

Adapting any leaf-type shutter for use with a single-lens reflex requires a mechanism to open the blades when the shutter is cocked. This adaptation is necessary because the light rays from the subject to be photographed must pass through the camera lens for viewing and focusing. Then, the light is reflected by a reflex mirror to the viewing screen, Fig. 6.

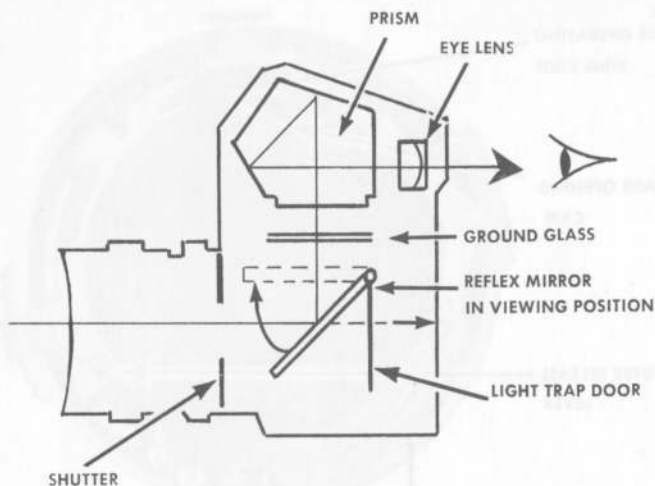

FIGURE 6

Most single-lens reflexes with leaf-type shutters have a light trap door behind the reflex mirror. This is also shown in figure 6. When the shutter blades are in the viewing (open) position, the light trap door protects the film by sealing the focal plane. In some cameras, the mirror itself seals off the focal plane in the viewing position.

When the shutter is released, the blades must first close to protect the film. Next, the reflex mirror and the light trap door are raised out of the focal plane. After the light trap door has uncovered the film, the blades open and close in the normal manner to make the exposure.

Advancing the film to the next frame lowers the light trap door to seal the focal plane, lowers the reflex mirror to the viewing position and cocks the shutter. At the end of the film advance cycle, the shutter blades are reopened for viewing. (Several single-lens reflexes with leaf-type shutters now have instant-return mirrors. This simply means that after the shutter has been released to make the exposure, the mirror immediately returns to the viewing position. The sequence of the shutter's operation, however, is the same.)

The mechanism used to operate the mirror, the light trap door, and the film advance is within the camera body. The action of the blades, however, is controlled by shutter parts. A cam which is press-fitted over the flattened cocking pinion shaft, Fig. 7, opens the blades at the end of the setting (cocking) cycle. As the cocking pinion is rotated on the setting stroke, this **blade opening cam** picks up a stud on the blade operating ring and moves the blades to the open position, Fig. 8. (This stud is on the "hooked" section of the blade operating ring, immediately beneath the closing stud.) Unlike the basic 00-MXV, the cocking pinion is not allowed to return until the shutter is released. Thus, the blades are retained in the open position for viewing and focusing.

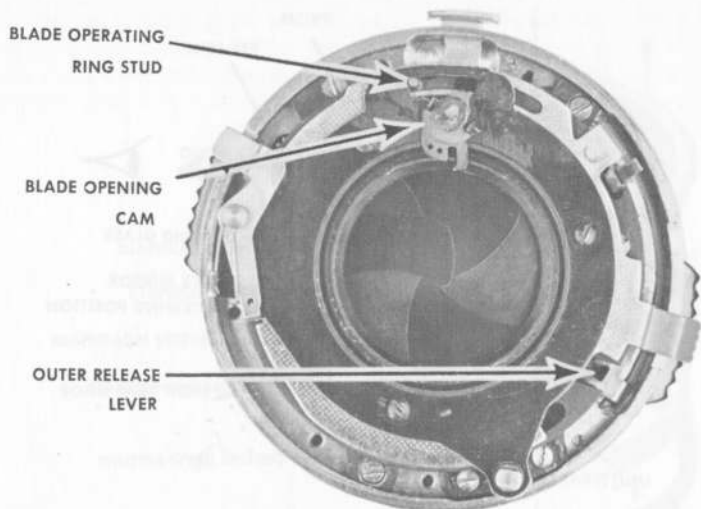

FIGURE 7 SHUTTER RELEASED

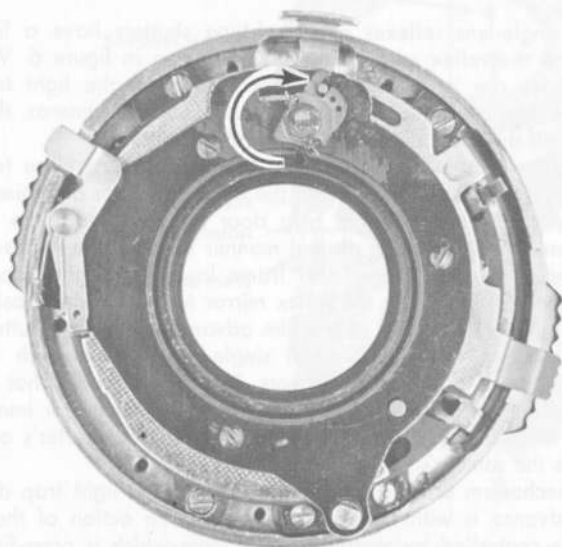

FIGURE 8 SHUTTER COCKED—ARROW INDICATES DIRECTION OF SETTING ROTATION

When the shutter is released, the cocking pin begins its return rotation. As it turns, the blade opening cam (still in contact with the stud on the blade operating ring) closes the shutter blades. Then the mirror and light trap door mechanism in the camera raise the reflex mirror and

light trap door, clearing the focal plane. Finally, when the cocking pinion reaches the end of its travel, the main drive cam is released to make the exposure. Advancing the film in the camera then initiates the sequence once again—the mirror and light trap door are lowered to seal off the focal plane, the shutter is cocked, and the blades are opened to the viewing position.

Since the Wide-Reflex is designed as a behind-the-lens shutter, it does not contain a diaphragm. Instead, a diaphragm is provided in each of the various interchangeable lenses used with this shutter. This is because lenses of different focal lengths require openings of varying diameters for the same effective f /stops. Two tabs, extending through the inside of the bayonet flange on the front of the shutter, control the diaphragm once the lens has been locked in place.

The diaphragm within each lens is spring-loaded. This spring tends to close the leaves to the smallest f /stop. It is up to the shutter mechanism to both open the diaphragm (against the spring tension) and to decide how far the spring is allowed to close the diaphragm according to the desired f /stop. These actions are controlled by the two tabs in the shutter's bayonet flange which couple to two corresponding tabs within the lens.

To accurately focus a single-lens reflex, the diaphragm should be in the wide-open position for minimum depth of field and maximum light on the viewing screen. Therefore, one of the two control tabs in the bayonet flange is coupled directly to the shutter mechanism, Fig. 9. When the shutter is cocked, opening the shutter blades, this tab travels down and moves the diaphragm in the lens to the full-open position, Fig. 10. As soon as the shutter is tripped, the tab moves upward and frees the diaphragm.

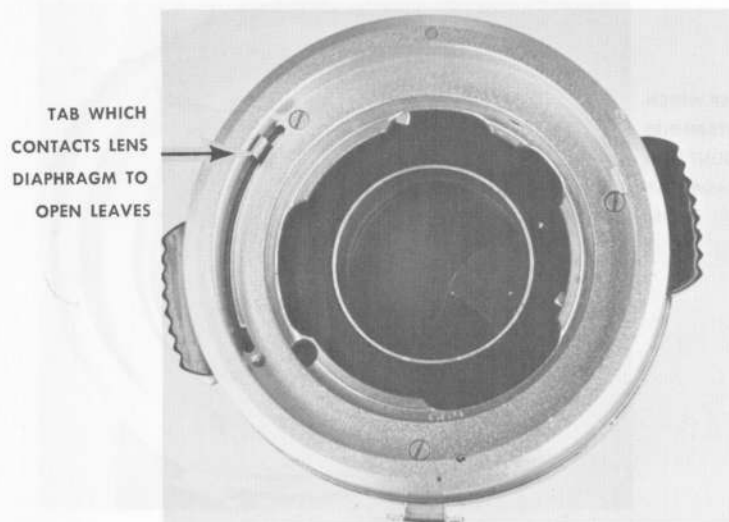

FIGURE 9

SHUTTER RELEASED

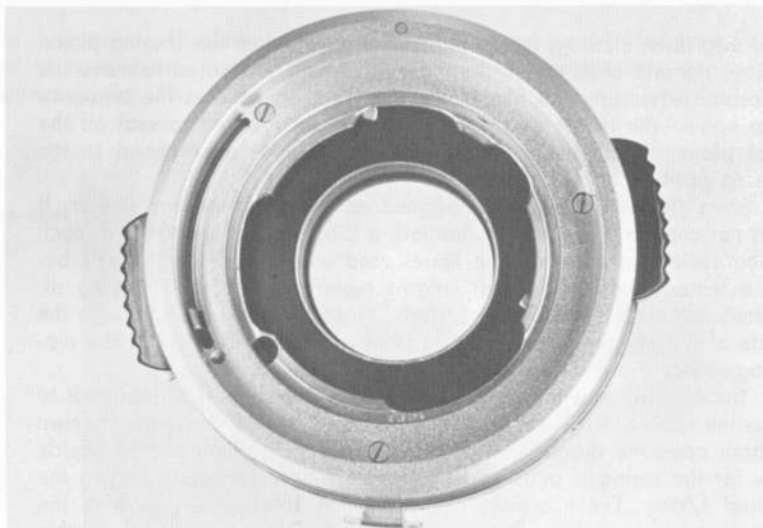

FIGURE 10 **SHUTTER COCKED**

While the shutter blades are closing, the diaphragm can stop down until it reaches a preselected f/stop (remember, the diaphragm is spring tensioned to close). The amount the diaphragm is allowed to stop down is governed by the second tab at the other side of the bayonet flange, Fig. 11. This tab is coupled to the shutter's diaphragm setting mechanism,

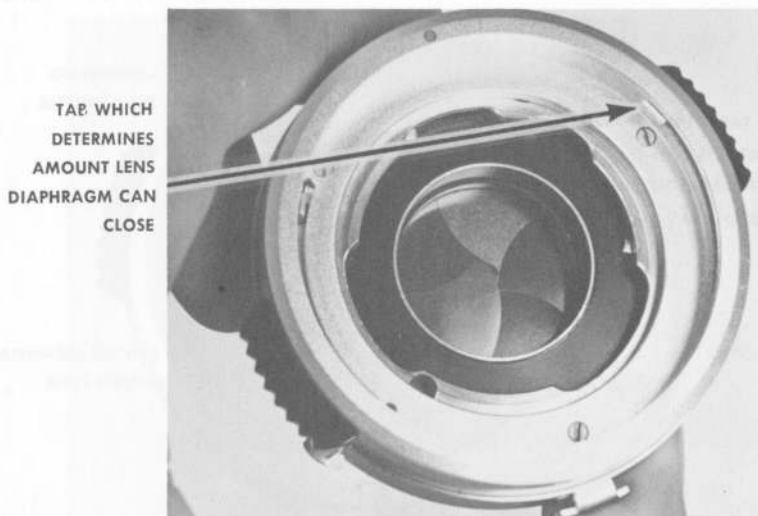

FIGURE 11

and its position was determined when the f/stop was selected. Thus, one tab opens the diaphragm for viewing, while the second tab decides the amount the diaphragm will be allowed to close according to the f/stop desired. Both functions are integral with the shutter and lens mount operation, and will be clarified during disassembly.

The modifications you have seen thus far have adapted the basic 00-MXV for use on a single-lens-reflex camera. That is, the shutter blades and the diaphragm (in the lens) are opened when the shutter is cocked, permitting through-the-lens viewing and focusing. Tripping the shutter permits the diaphragm to stop down appropriately and the blades to close—leaving sufficient time for the mirror and light trap door in the camera to clear the focal plane before the blades reopen and close for the exposure. Also, the cocking pinion, cocking ring and outer release lever (as well as several other parts which you will later see) have been modified so the shutter can be set and released by internal camera controls. There is one more addition to the basic 00-MXV making it the Wide-Reflex—this is the **light value mechanism**, a sub-assembly attached to the front of the shutter.

Basically, the purpose of this mechanism is similar to that of the coupling parts in the Prontor 500 LK covered in *Net Cam Manual* #276; that is, to program the shutter to a built-in meter, simplifying the problem of setting the correct exposure. However, the Compur light value mechanism is more complex and involved than the simple rings and cam in the Prontor 500 LK.

From the back of the shutter, **locate the light value stem** opposite the blade opening cam (shown in figures 12 and 13). When the shutter is mounted on the camera, the light value stem couples to the camera exposure setting controls. It extends from this point into the light value mechanism, providing the link between the camera exposure setting controls and the shutter.

SHUTTER MOUNTING
SCREWS

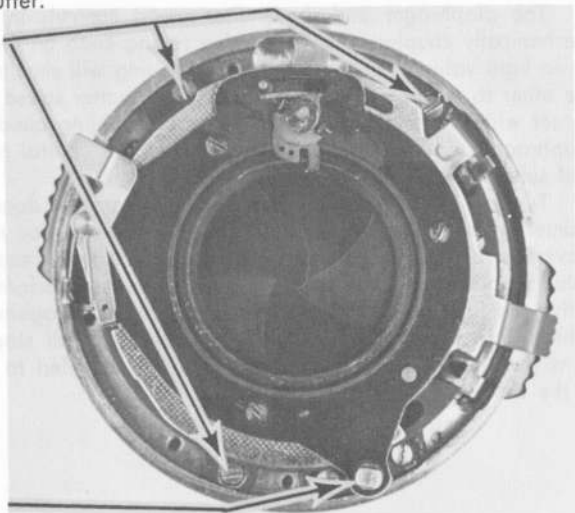

LIGHT VALUE STEM

FIGURE 12

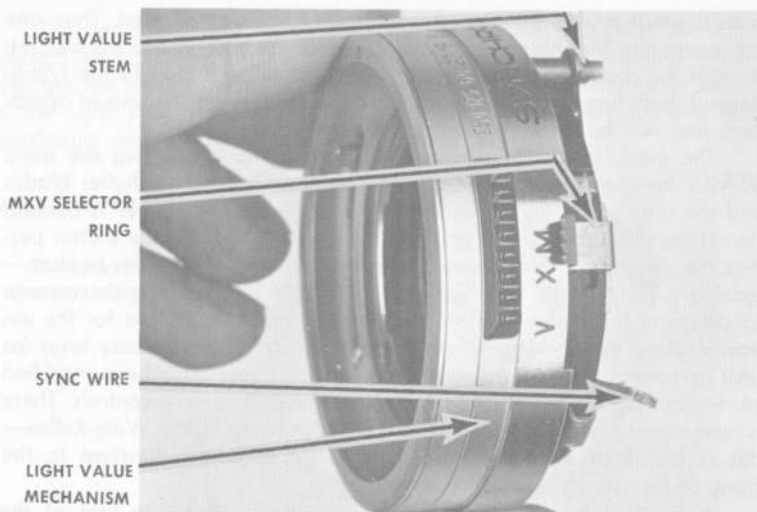

FIGURE 13

Briefly, this is how the light value mechanism works (the operation will be detailed during disassembly, covered later in the text): each light value (also termed "exposure value") represents the combination of shutter speed and f /stop which results in a particular exposure. Any combination of settings which will deliver a given exposure has the same light (for example, $1/30$ second at $f/8$, $1/60$ second at $f/5.6$ and $1/125$ second at $f/4$ all have the same light value because the exposure remains constant).

The diaphragm and the shutter speed controls in the shutter are mechanically coupled to a light value setting knob on the camera. For a given light value, then, changing either setting will simultaneously correct the other to retain the same exposure. The shutter speed and f /stop can be set with one knob to correspond to the lighting conditions, using the diaphragm and shutter speed scales merely for control of depth of field and subject movement respectively.

Turning the light value knob (on the camera) does two things: a pointer over the exposure meter needle is moved (or the entire meter movement is turned, depending on the particular camera), and the light value stem is rotated. The light value stem in turn performs two functions within the light value mechanism: it positions the diaphragm setting ring (which determines how far the lens diaphragm will stop down) and it turns the shutter speed setting ring (which is coupled to the speed cam in the shutter), Fig. 14.

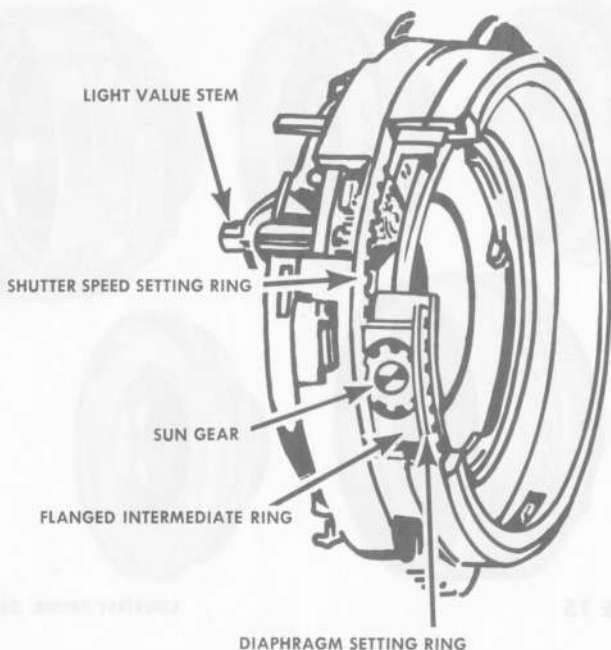

FIGURE 14

All that is necessary to set the correct exposure is to rotate the light value knob until the pointer aligns with the needle. This selects the correct light value (shutter speed/diaphragm combination) for the light intensity. Now, the settings which will be delivered when the shutter is released can be directly read from the scales on the light value mechanism. While retaining the correct light value, the shutter speed/diaphragm combination which best suits the picture requirements can be selected.

To change this combination, turn the shutter speed setting ring (using its two plastic finger grips) on the light value mechanism. The diaphragm setting ring will then follow the new shutter speeds by corresponding f /stops to retain the correct light value. Some cameras optically reflect both the scale readings and the meter needle onto the ground glass, permitting you to view the subject, focus the lens and set the exposure without moving your eye from the viewfinder.

Even the problem of reading depth-of-field scales to choose the best f /stop has been simplified. The bayonet flange on the front of the Wide-Reflex accepts the Compur Quick-Change lens mounts, Fig. 15. These mounts, available with lenses of various focal lengths, all contain a spring-loaded diaphragm, Fig. 16, and an automatic depth-of-field indicator.



FIGURE 15

COURTESY FRIEDR. DECKEL

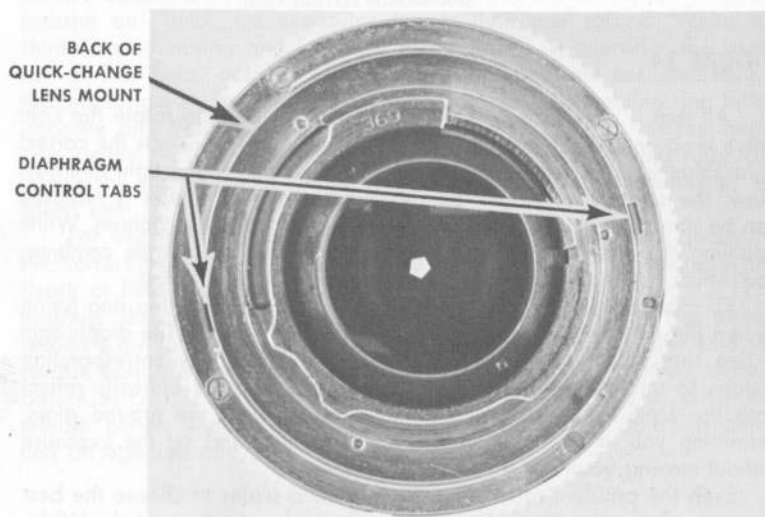

BACK OF
QUICK-CHANGE
LENS MOUNT

DIAPHRAGM
CONTROL TABS

FIGURE 16

Setting the f /stop causes two red indicators to move along the distance scale on the Quick-Change lens mount, Fig. 17. The depth of field which will result from the selected f /stop can then be read within the indicators (that is, the minimum and maximum distances at which an object will be in acceptable focus).

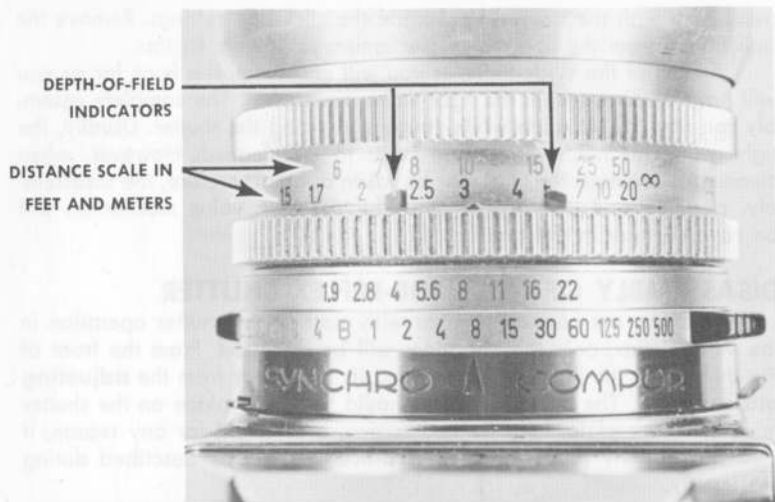

FIGURE 17 SYNCHRO-COMPUR 00-MXV WIDE-REFLEX INSTALLED ON RETINA REFLEX WITH QUICK-CHANGE LENS MOUNT IN PLACE

Although the light value mechanism is fairly complex and has several timing considerations, the technician has one advantage: this unit is a complete sub-assembly which rarely requires disassembly when servicing the shutter. The shutter and the light value mechanism can be separated after removing the three screws through the shutter mounting lugs, Fig. 12, (this operation should be done with the shutter in the released position). When you lift off the light value mechanism, be careful to avoid losing the ball detent, Fig. 18. This ball engages slots in the speed cam

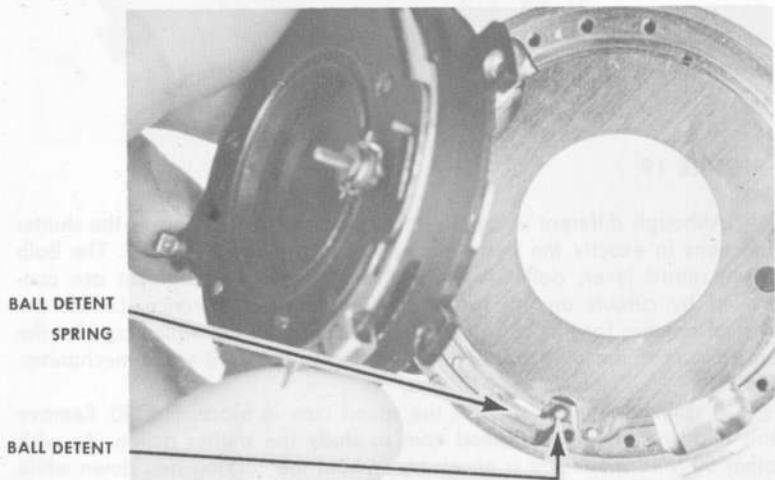

FIGURE 18

(remaining with the shutter) to provide the click-stop settings. Remove the ball detent from the light value mechanism to prevent its loss.

In most of the Wide-Reflexes you will encounter, this is as far as you will have to disassemble the light value mechanism. The complete assembly can now be set aside while you are servicing the shutter. Usually, the light value mechanism does not have to be cleaned. However, when cleaning is required the unit must be taken apart. Therefore, the disassembly, cleaning and timing procedures for the light value mechanism will be covered later in the text.

DISASSEMBLY OF THE WIDE-REFLEX SHUTTER

Since you are already familiar with most of the shutter operation in the Wide-Reflex, only the variations will be discussed. From the front of the shutter, lift the light value stem and its idler gear from the **adjusting plate**, Fig. 19. The adjusting plate should be left in place on the shutter housing. If this plate, held by two screws, is removed for any reason, it must be properly repositioned—this procedure will be described during reassembly.

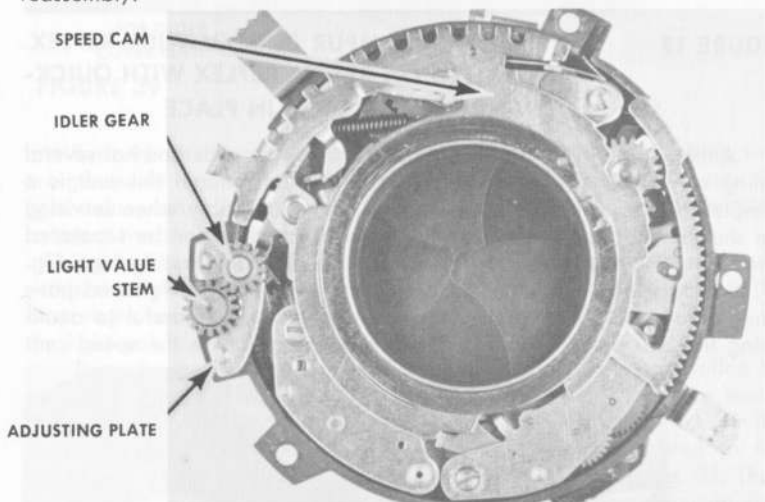

FIGURE 19

Although different in appearance, the speed cam controls the shutter functions in exactly the same manner as in the basic 00-MXV. The bulb lever, retard lever, pallet lever and retard first gear segment are controlled by cutouts on the speed cam's outer circumference. Locate the row of notches for the ball detent and the vertical tab which couples the speed cam to the shutter speed setting ring in the light value mechanism, Fig. 20.

A split retaining clip holds the speed cam in place, Fig. 20. Remove this clip and lift off the speed cam to study the shutter action. As with other 00-MXV models, it is necessary to hold the cocking ring down while operating the shutter at this stage of disassembly.

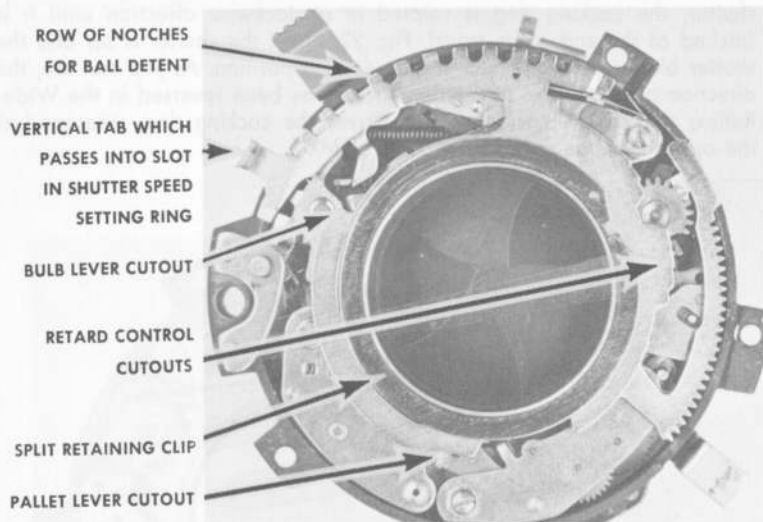

FIGURE 20

As previously mentioned, the cocking pinion does not return from the set position until the shutter is released. This modification is necessary because the blades must be held open for viewing. To hold the cocking pinion in the set position, the cocking ring is latched at the end of its setting rotation.

Locate the **cocking ring latch** which has been added above the blocking lever, Fig. 21. When the cocking pinion is turned to set the

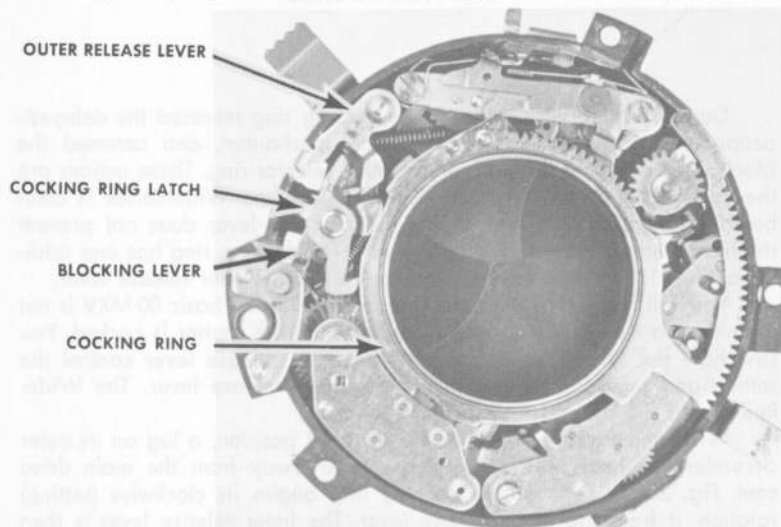

FIGURE 21

shutter, the cocking ring is rotated in a clockwise direction until it is latched at the end of its travel, Fig. 22. Now, the shutter is set and the shutter blades are held open in the viewing position. As you can see, the direction of control on the setting stroke has been reversed in the Wide-Reflex; that is, the cocking pinion drives the cocking ring, whereas just the opposite is the case in the basic 00-MXV.

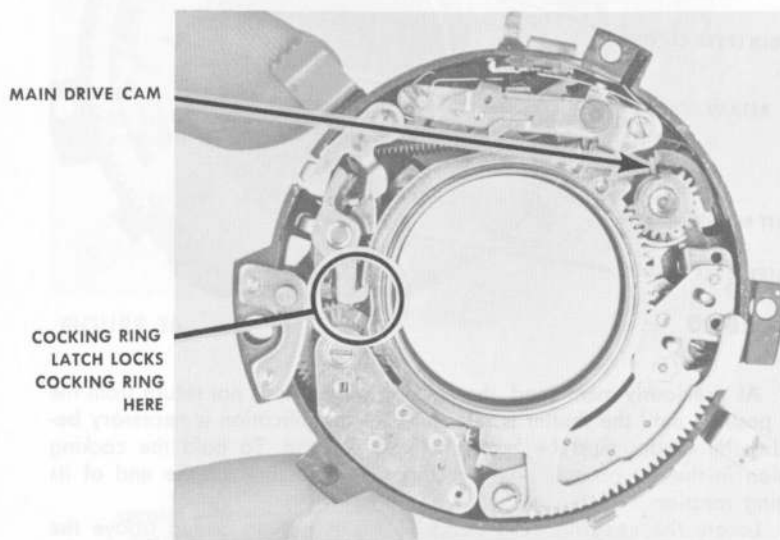

FIGURE 22 **SHUTTER COCKED**

During its clockwise rotation, the cocking ring released the delayed-action locking lever, set the sync delay mechanism, and cammed the blocking lever out of the path of the MXV selector ring. These actions are the same as those in the basic 00-MXV (since the Wide-Reflex is combined with the camera mechanism, the blocking lever does not prevent the movement of the outer release lever). The cocking ring has one additional duty in the Wide-Reflex: the control of the inner release lever.

You will recall that the inner release lever in the basic 00-MXV is not permitted to move to its latching position until the shutter is cocked. You saw how the sync drive sector and the outer release lever control the setting and releasing movements of the inner release lever. The Wide-Reflex uses the cocking ring for both functions.

When the cocking ring is in the released position, a lug on its outer circumference holds the inner release lever away from the main drive cam, Fig. 23. As soon as the cocking ring begins its clockwise (setting) rotation, it frees the inner release lever. The inner release lever is then moved by its spring into position to latch the main drive cam, Fig. 22.

COCKING RING
DISENGAGES
INNER RELEASE
LEVER HERE

OUTER RELEASE
LEVER STRIKES
COCKING RING
LATCH HERE

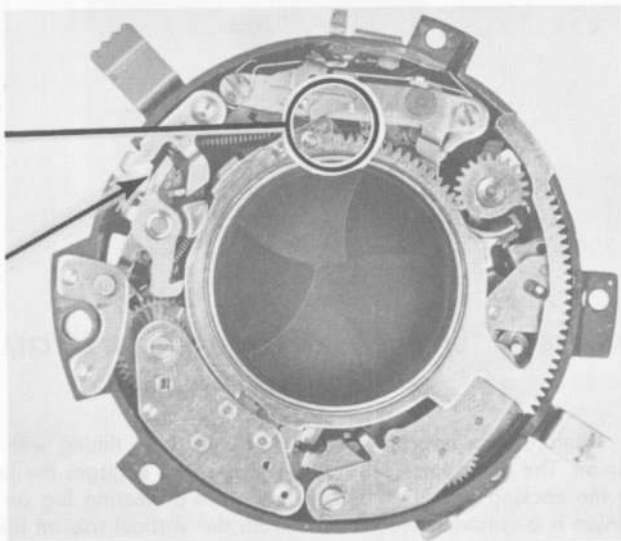

FIGURE 23

SHUTTER RELEASED

To trip the shutter, the outer release lever strikes the tail of the cocking ring latch and frees the cocking ring. Now, the cocking ring turns in a counterclockwise direction under spring tension. During the first portion of its movement, the cocking ring carries the cocking pinion far enough to close the shutter blades. Then, at the end of its travel the cocking ring once again contacts the inner release lever. This kicks the inner release lever out of engagement with the main drive cam to make the exposure.

Remember, there are several events which must occur before the shutter blades open and close to expose the film. This is why the cocking ring is used to release the shutter. The length of time required for the cocking ring to travel from its latched position (figure 22) to the point where it disengages the inner release lever (figure 23) allows the shutter blades to close, the lens diaphragm to stop down to the proper f /stop, the mirror to rise and the light trap door to uncover the focal plane. This is the necessary sequence for a leaf-type shutter in a single-lens-reflex camera.

Using tweezers, lift the cocking ring latch/blocking lever assembly straight up from its post. The two parts are one unit with a common spring, Fig. 24.



**FIGURE 24 UNDERSIDE OF COCKING RING LATCH/
BLOCKING LEVER ASSEMBLY**

Before removing the cocking ring, notice its timing with the cocking pinion. The first gear tooth in the cocking ring engages the first tooth-slot in the cocking pinion. Still, the downward-projecting lug on the cocking pinion is a considerable distance from the vertical tab on the main drive cam, Fig. 25. This means that the cocking pinion must travel a partial revolution before it contacts the main drive cam. Also, locate the geared rack on the cocking ring near the outer edge of the shutter housing. When the shutter is mounted on the light value mechanism, this rack engages a pinion to control the diaphragm opening ring. This action will be described later in the text.

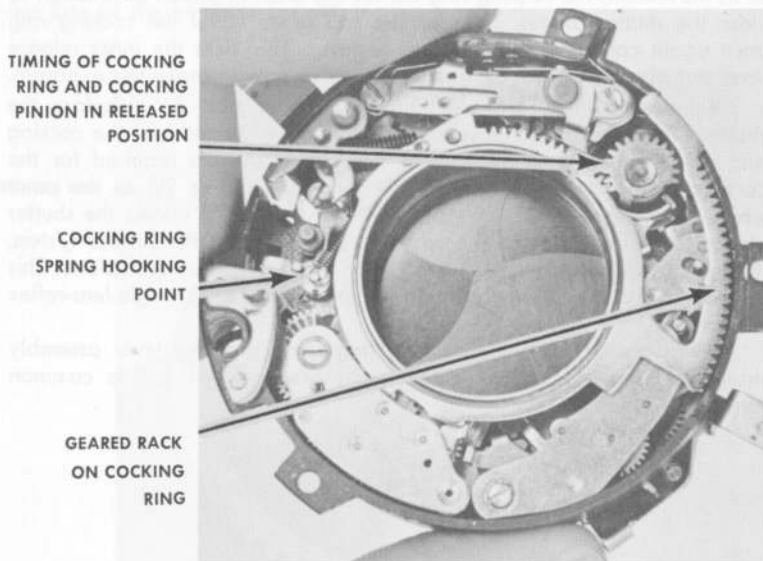

FIGURE 25

Rather than hooking on the V-latching lever as in the basic 00-MXV, the cocking ring spring is secured to a post on the notched bulb lever screw, Fig. 25. Remove the cocking ring by lifting it up from the lens flange.

The blade opening cam must be pried off the shaft from the back of the shutter before the cocking pinion can be removed (the blade opening cam is shown in figure 7). Since this is a tight fit, extreme care should be used to avoid bending the cocking pinion shaft or damaging the blade opening cam. There are various methods you can use to remove the blade opening cam, three of which are described here:

1. Wedge heavy work tweezers under the blade opening cam with one point on either side of the cocking pinion shaft. Now, carefully press the tweezers toward the blade opening cam. This will slowly work the blade opening cam up and off the cocking pinion shaft.
2. Two screwdriver blades can be pressed under the blade opening cam, one on either side. By lifting the screwdrivers alternately, the blade opening cam may be gradually worked up from the cocking pinion shaft.
3. A conventional gear puller may be modified so its jaws can be slipped under the blade opening cam. This method limits the chances of damage because the blade opening cam will be pulled straight up from the cocking pinion shaft.

Remove the delayed action, speeds escapement, and main drive cam, using the same procedures as in the basic 00-MXV. Notice that the outer release lever spring hooks against the sync bridge post rather than against the side of the shutter housing. Using the tips of your tweezers, hold the spring away from the post while you lift the outer release lever from its bushing, Fig. 26.

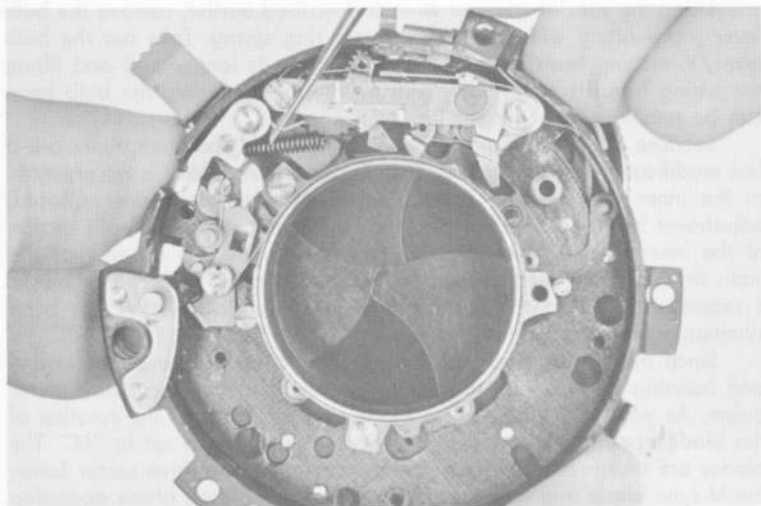

FIGURE 26

The bulb lever and the V-latching lever work in the same manner as their counterparts in the basic 00-MXV. However, their springs are quite different in type and in location. In the Wide-Reflex one spring serves to move both levers toward the center of the shutter. A separate spring seats around the notched bulb lever screw. The shorter end of this spring contacts the post on the MXV selector ring, while the longer end rests against the lens flange, Fig. 27. (Note: the term "lens flange" has been retained for reference—however, in the Wide-Reflex the part is not threaded to receive a lens cell.)

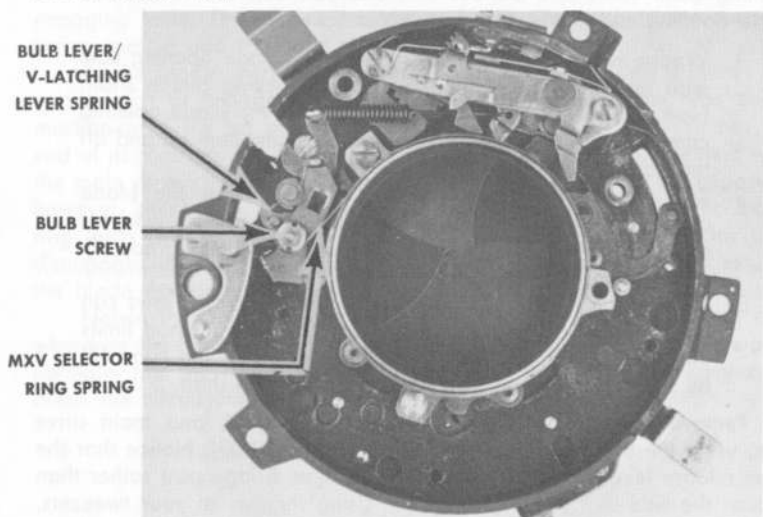

FIGURE 27

Using the special spanner wrench described earlier, remove the bulb lever screw along with the MXV selector ring spring. Take out the bulb lever/V-latching lever spring by disconnecting its longer end and lifting the spring from its post. Now, with a little manipulation, the bulb lever can be removed from the shutter.

Because of the difference in the cocking ring's operation, there are a few modifications in the sync section. For one thing, there is no eccentric at the inner release lever pivot point. Even when parts are replaced, adjustment is not required at this position. (If necessary, the split section of the inner release lever, Fig. 28, can be reformed to assure that the main drive cam is freed properly.) Also, the cocking lock (which blocks a repeated stroke of the cocking ring in the basic 00-MXV) has been eliminated from the sync drive sector.

Since the blades must be opened prior to an exposure for viewing and focusing there is one additional lever within the sync delay mechanism. As you know, the M-sync blade ring latch arrests the rotation of the blade operating ring when the MXV selector ring is set to "M." The blades are thus prevented from opening until the sync drive sector forces the M-sync blade ring latch out of engagement with the blade operating ring (after the proper delay). In order to open the blades for viewing,

INNER RELEASE
LEVER MAY BE
ADJUSTED HERE

LATCH
DISENGAGING
LEVER

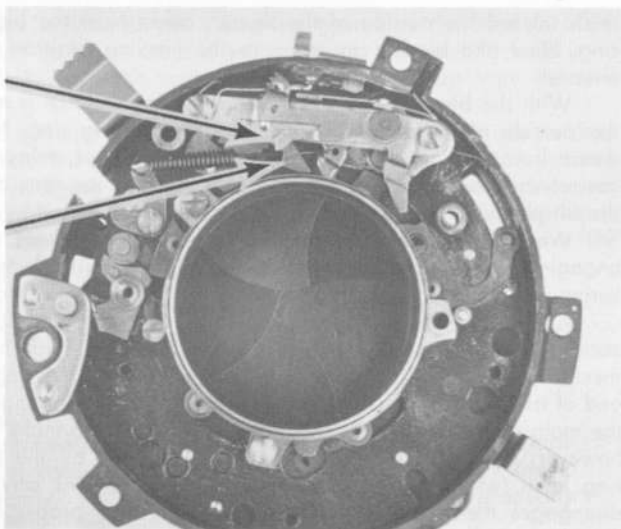

FIGURE 28

then, the M-sync blade ring latch must be held away from the blade operating ring on "M" sync. This is done by the **latch disengaging lever**, Fig. 28, which is riveted to the underside of the sync bridge.

One end of the latch disengaging lever contacts the vertical tab on the M-sync blade ring latch. The other end extends from under the tab on the sync bridge into the path of the cocking ring (this end is seen in figure 28). When the cocking ring is turned in a clockwise direction on the setting stroke, it strikes the visible end of the latch disengaging lever, simulated in figure 29. The latch disengaging lever forces the M-sync blade ring

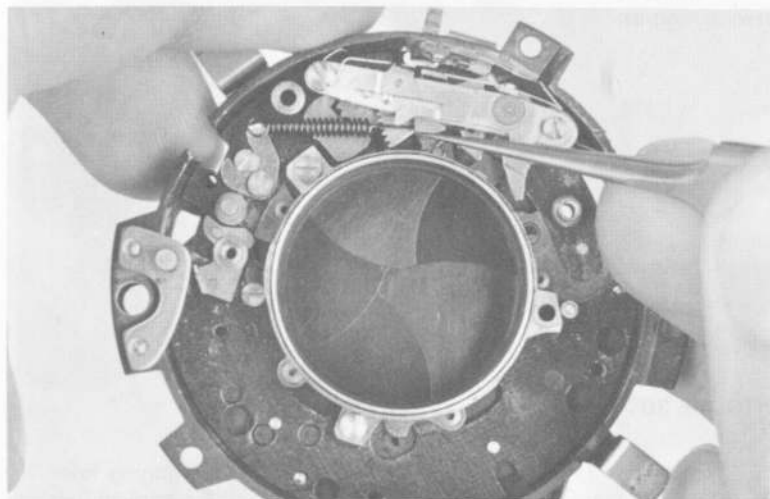

FIGURE 29

latch toward the outside of the shutter, away from the blade operating ring. Now, the blades can open to the viewing position without interference.

With the blades open for viewing, the sector latch is moved toward the outside of the shutter by the blade operating ring. Normally, this would free the sync drive sector. However, the sync delay mechanism is not released because the cocking ring still holds the sync drive sector in the set position.

When the shutter is released, the cocking ring frees the latch disengaging lever. This allows the M-sync blade ring latch to move under spring tension into the path of the blade operating ring (on "M" sync).

As the blade operating ring returns to close the blades, it allows the sector latch to engage the sync drive sector and hold the sync delay mechanism in the set position. Now, when the cocking ring reaches the end of its rotation, it kicks the inner release lever out of engagement with the main drive cam. Before the blades can reopen to make the exposure, however, the blade operating ring is intercepted by the M-sync blade ring latch (when the shutter is set to "M"). The sync drive sector then disengages the M-sync blade ring latch after the proper delay to free the blade operating ring.

Notice that the sync contact is closed by the blade operating ring whenever the blades are in the viewing position, Fig. 30. Since this would normally fire the flash, a safety switch is needed within the camera to break the circuit until the shutter is released.

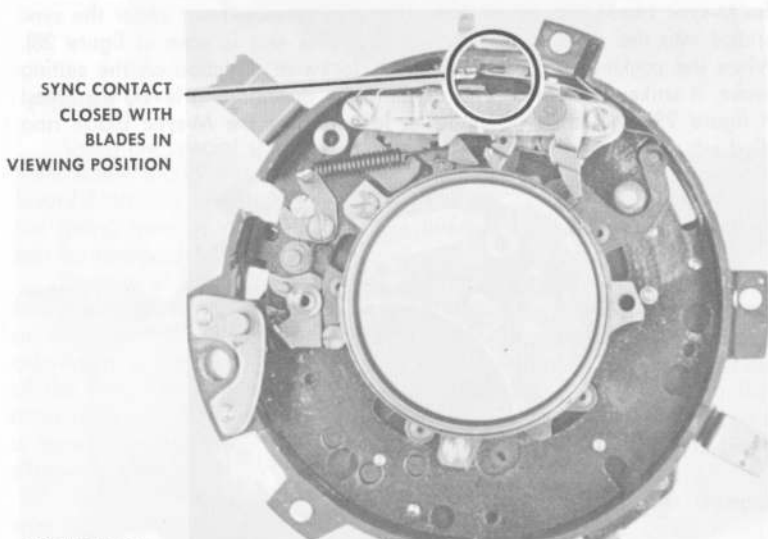

FIGURE 30

Remove the sync bridge and locate the latch disengaging lever on its underside, Fig. 31. On reassembly, be sure that the vertical tab on the latch disengaging lever is against the corresponding tab on the M-sync

blade ring latch, Fig. 32. The remaining operation of the sync delay mechanism is the same as that in the basic 00-MXV, and disassembly is accomplished in the normal way.

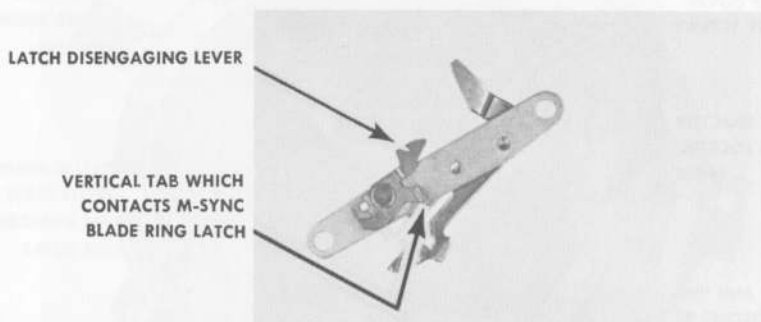

FIGURE 31

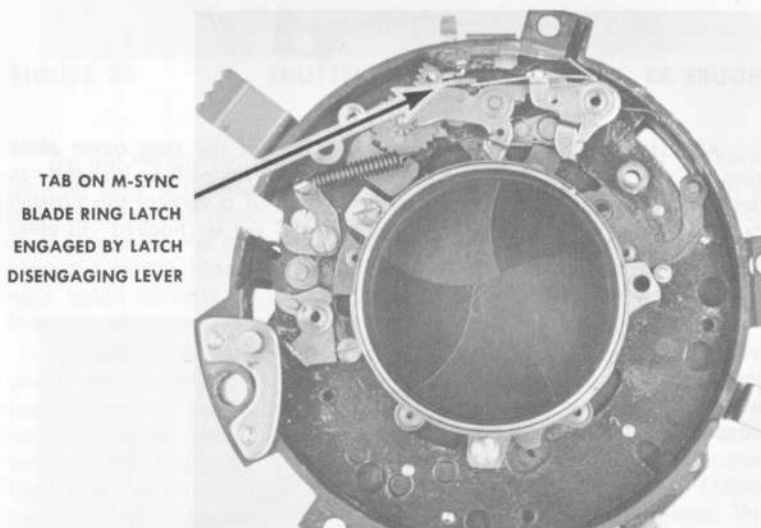

FIGURE 32

From the back of the shutter, locate the spring-loaded lever on the rear cover plate which engages in either of two notches on the MXV selector ring, Fig. 33. The two notches correspond to the "M" and "X" settings. Before the MXV selector ring can be moved to another setting, the lever must first be depressed. This decreases the chances of accidentally turning the MXV selector ring to an undesired setting.

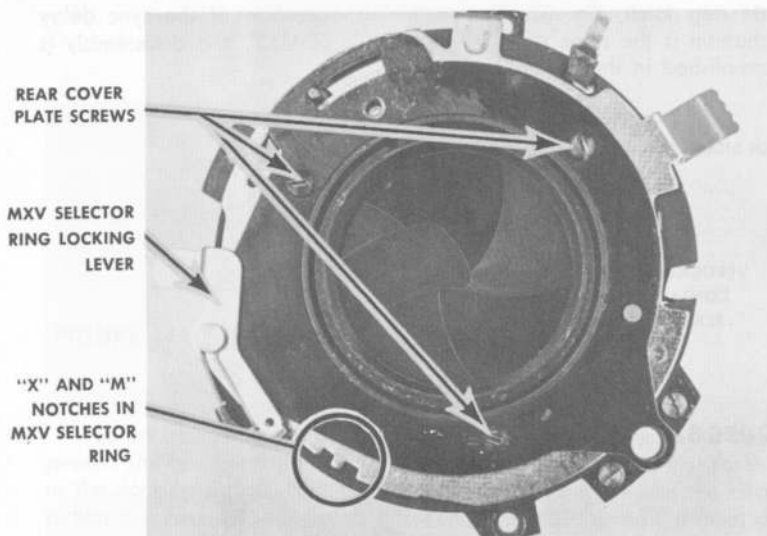

FIGURE 33

After removing the three screws, Fig. 33, lift the rear cover plate from the shutter. Next, take out the MXV selector ring, tilting it slightly to clear the slot in the side of the shutter. Instead of a vertical tab passing through the bottom of the shutter, the serrated lug is "hooked" to enter the side of the housing, Fig. 34.

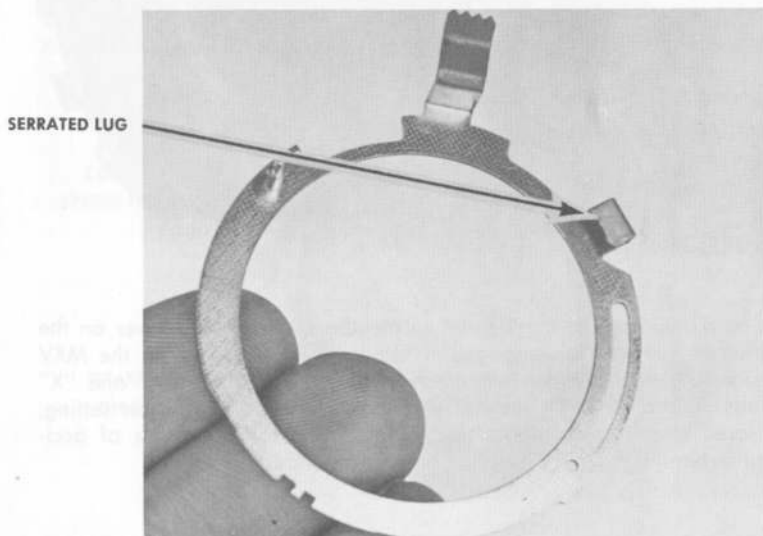

FIGURE 34

The remaining disassembly is virtually the same as that in the basic 00-MXV. The only major variation you will now encounter is in the number, shape, and rotation of the shutter blades. This is a very important consideration on reassembly.

As additional assurance against light penetration, a sixth blade (cover blade) has been added. The cover blade is easily recognized because of its smaller size and unique shape, Fig. 35. Also, because the cocking pinion shaft extends through the back of the shutter, the second blade is modified to provide clearance. The second blade, recessed slightly along its top edge, is not as easily distinguished from the four "conventional" blades. However, its position on the blade operating ring is critical.

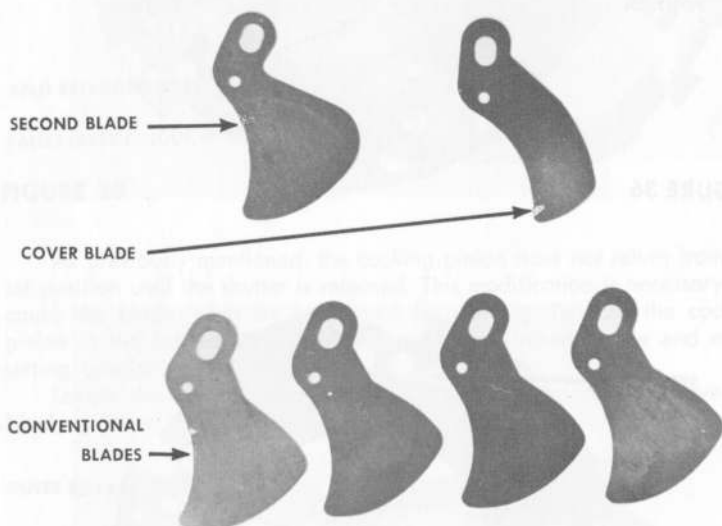

FIGURE 35

After the shutter has been cleaned and you are ready to install the blades, seat the first conventional blade at the second pin position counterclockwise to the main drive cam bushing, Fig. 36. Then, seat the second blade at the pin position nearest the main drive cam bushing, Fig. 37. You can see that if one of the conventional blades were placed here, it would cover the hole in the bushing when the blades were opened. Thus, it would strike the cocking pinion shaft on the opening cycle and jam the shutter. The remaining three conventional blades are replaced in clockwise rotation. Finally, install the cover blade on top of the first blade, Fig. 38.

MAIN DRIVE CAM
BUSHING

FIRST BLADE
POSITION

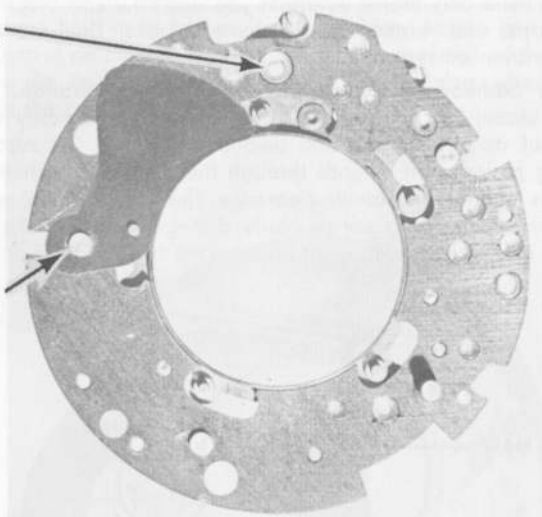

FIGURE 36

SECOND
BLADE

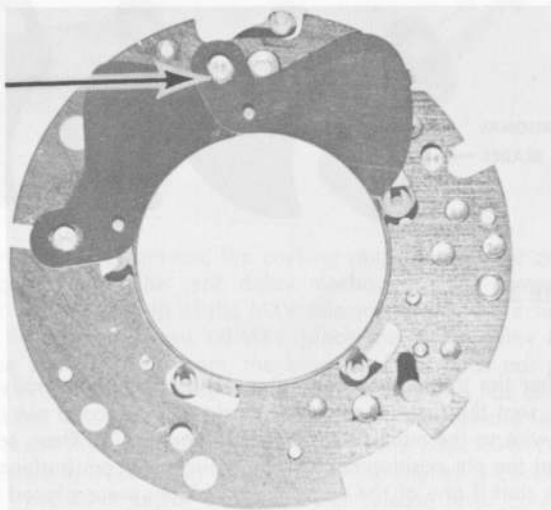

FIGURE 37

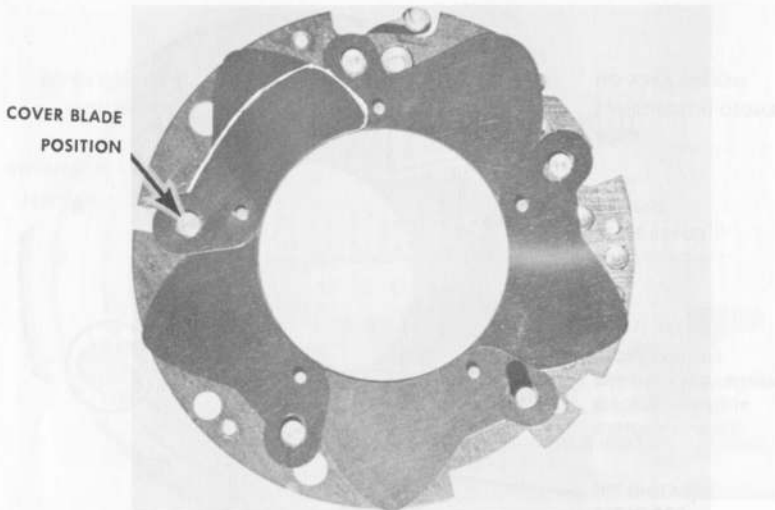

FIGURE 38

Complete the shutter reassembly and lubrication by referring to the text covering the basic 00-MXV. Pay particular attention to the variations you observed during disassembly. Additional points of lubrication are the surfaces on the outer circumference of the cocking ring which contact the inner release lever and the cocking ring latch.

After installing the cocking pinion, check it carefully for freedom of movement. If the cocking pinion shaft was accidentally bent when the blade opening cam was removed, it will bind within the main drive cam bushing.

You must support the cocking pinion from the mechanism side of the shutter while pressing the blade opening cam into place. The shutter cocking tool you made (figure 4) is also handy for replacing the blade opening cam. With the cocking pinion supported, use the shutter cocking tool to push the blade opening cam onto the shaft.

DISASSEMBLY OF THE LIGHT VALUE MECHANISM

As previously mentioned, the light value mechanism is not normally disassembled or cleaned when servicing the shutter. If the assembly does require cleaning, however, it should never be placed intact in a commercial cleaning machine. The solutions and the heat of the drier can damage the plastic finger grips on the shutter speed setting ring.

From the back of the light value mechanism, locate the brass gear rack through the cutout in the bayonet flange, Fig. 39. This rack is part of the **flanged intermediate ring** inside of the assembly. When the shutter is mounted on the light value mechanism, the idler gear on the adjusting plate (figure 19) engages the geared rack on the flanged intermediate ring. Thus, turning the light value stem rotates the flanged intermediate ring through the idler gear.

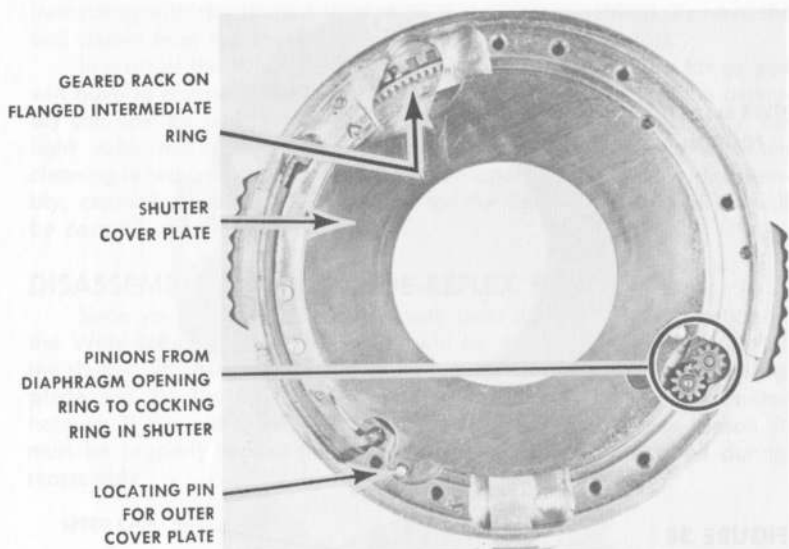

FIGURE 39

Both the shutter speed setting ring and the diaphragm setting ring are geared to the flanged intermediate ring. Therefore, when you turn the light value setting knob (on the camera), the light value stem is rotated to select the shutter speed and the f/stop.

You will recall that the lens diaphragm is controlled by the two tabs within the light value mechanism. The tab which governs the amount the diaphragm can close is part of the diaphragm setting ring, positioned by the light value stem.

The other tab is part of the diaphragm opening ring, controlled by the shutter. Notice the two pinions on the back of the light value mechanism—the higher pinion normally meshes with the geared rack on the cocking ring in the shutter, while the lower pinion is geared to the diaphragm opening ring within the light value mechanism, Fig. 39. Thus, the shutter's cocking ring directly controls the diaphragm opening ring through these two pinions.

Before turning over the light value mechanism, lift off the shutter cover plate and the higher pinion (the lower pinion, permanently attached to its post, cannot be removed). The spring-loaded lever now revealed is the lens locking lever, used to latch the Quick-Change lens mount in the bayonet flange, Fig. 40.

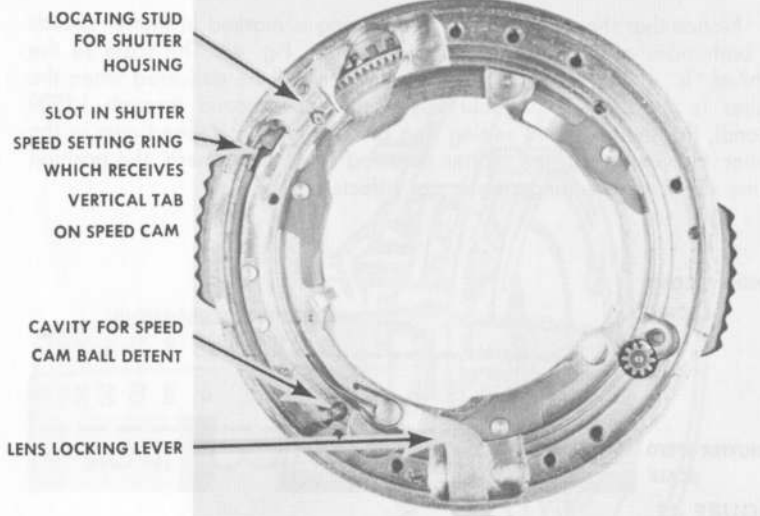

FIGURE 40

Three screws on the front of the light value mechanism hold the assembly together, Fig. 41. Once these screws are removed, the timing between the diaphragm setting ring and the shutter speed setting ring will be lost. It is, therefore, important to observe the relationships of the two scales at the various settings prior to disassembly.

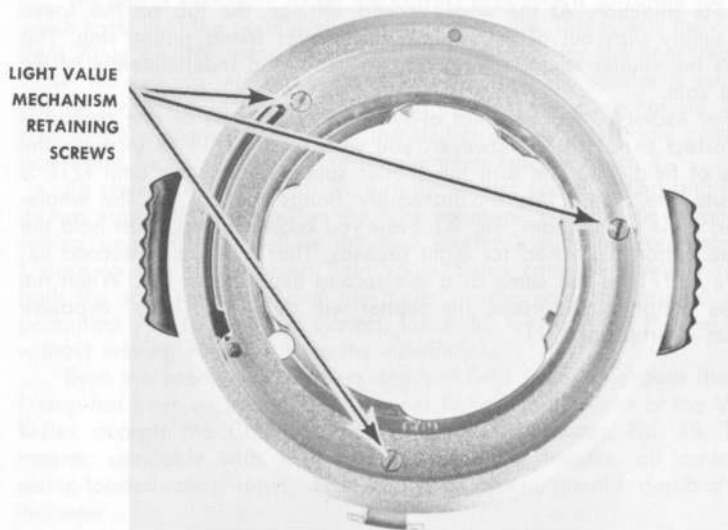

FIGURE 41

Notice that the shutter speed setting ring is marked in shutter speeds on both sides of the "B" ("bulb") calibration, Fig. 42. The scale to the right of "B" indicates the shutter speed which will be delivered when the shutter is released. Throughout this range (one second through 1/500 second), the shutter speed setting ring directly turns the speed cam in the shutter. However, with the shutter removed from the camera, the position of the diaphragm setting ring is not affected.



FIGURE 42

The second scale, "4" through "250" on the other side of the "B" calibration, provides a reference for time exposures. (This scale has green numbers which appear lighter in the illustrations.) The green scale is in **whole seconds** to indicate how long the release should be held depressed on "bulb" for exposures longer than one second. When the shutter speed setting ring is turned to this range, it overrides the speed cam at the "bulb" position. Now, the shutter speeds are not affected, but the diaphragm setting ring turns with the shutter speed setting ring in the opposite direction. At the whole-second settings, the tab on the speed cam simply slips out of its notch in the shutter speed setting ring. This allows the shutter speed setting ring to be turned independently of the speed cam.

For example, suppose that at $f/4$ a shutter speed of one second is the correct exposure. If, however, you wish to use $f/11$ to increase the depth of field, you can turn the shutter speed setting ring until $f/11$ is opposite the index. This simultaneously brings the "8" on the whole-second scale to the index, Fig. 43. Now you know that you must hold the release button depressed for eight seconds. That is, an eight-second exposure at $f/11$ is the same as a one-second exposure at $f/4$. When the release button is depressed, the shutter will deliver a "bulb" exposure and an aperture of $f/11$.



FIGURE 43 SYNCHRO-COMPUR 00-MXV WIDE-REFLEX
INSTALLED ON RETINA REFLEX

With the light value mechanism removed from the shutter, a spring turns the diaphragm setting ring to the full-open position, as shown in figure 42. Notice that when the shutter speed setting ring is on "B," the diaphragm setting ring is on "1.9." As soon as the shutter speed setting ring is moved past the "B" setting on the whole-second side of the scale, the diaphragm setting ring rotates in the opposite direction. This is the timing that is an important consideration on reassembly.

After you have studied the proper timing, begin disassembly by removing the three front screws. Now, grasp the two plastic finger grips on the shutter speed setting ring and lift off the top part of the assembly, Fig. 44.

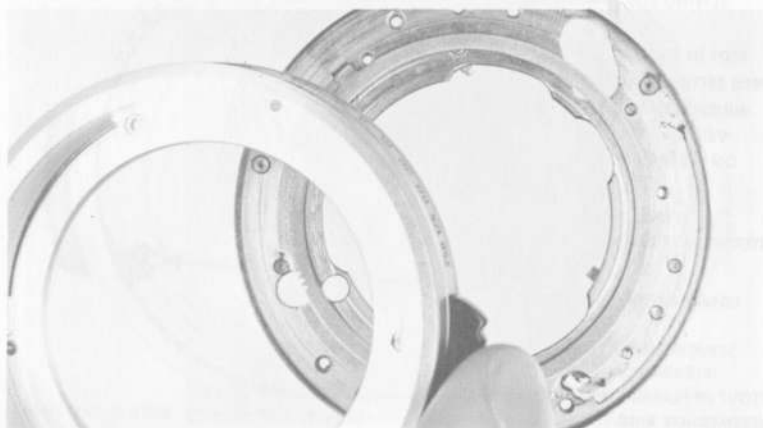

FIGURE 44

The one loose part remaining with the bayonet flange is the diaphragm opening ring, Fig. 45. Locate the geared rack on this ring which engages the lower pinion (the pinion remained with the outer cover plate of the light value mechanism) and the vertical tab which contacts the diaphragm control ring in the Quick-Change lens mount.

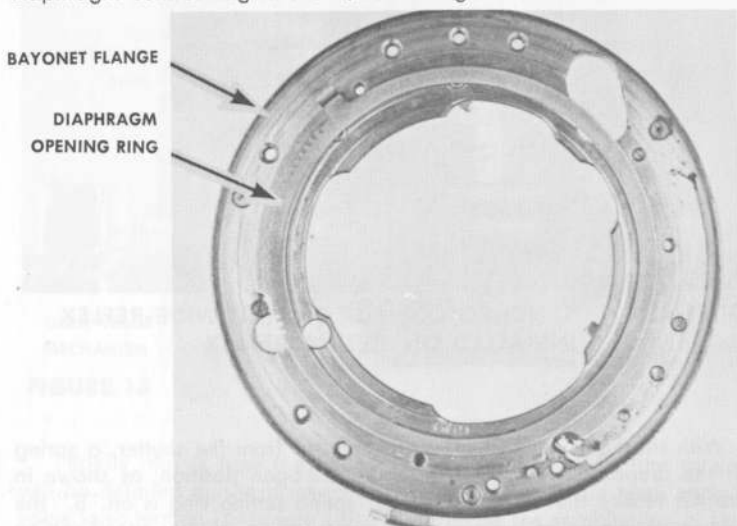

FIGURE 45

Carefully turn over the front portion of the assembly while holding it together. The two rings now visible are the shutter speed setting ring (on top) and the flanged intermediate ring, Fig. 46. A row of flat-topped

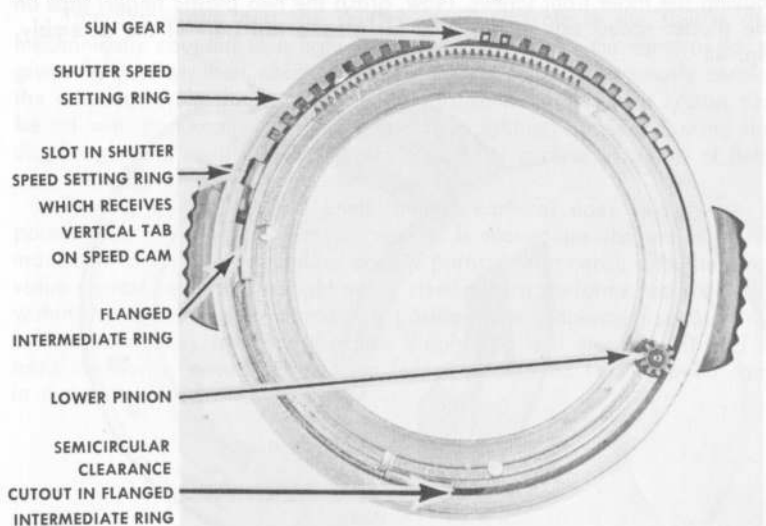

FIGURE 46

teeth on the shutter speed setting ring engages a free-turning **sun gear** on the flanged intermediate ring.

Since the light value mechanism is now at the largest-f/stop position, the shutter speed setting ring can be turned counterclockwise without moving the diaphragm setting ring (under the flanged intermediate ring and not yet visible). However, as soon as the shutter speed setting ring is rotated to the whole-second scale, the sun gear picks up the diaphragm setting ring. Thus, the diaphragm setting ring is turned in the opposite direction against its spring tension.

When the light value mechanism is assembled, the diaphragm setting ring and the shutter speed setting ring can be turned together by rotating the light value stem. This is because the light value stem turns the flanged intermediate ring through the idler gear.

If the shutter were mounted on the camera, the shutter speed setting ring could be moved to select the exposure time while simultaneously turning the diaphragm setting ring to maintain the correct light value. Of course, once the light value mechanism is removed, the diaphragm setting ring is rotated by its spring to the full-open position. Thus, since faster speeds would demand larger f/stops, the shutter speed setting ring can be turned freely counterclockwise past the "B" calibration without affecting the diaphragm setting ring. However, if the diaphragm setting ring is positioned at a smaller f/stop, its timing with the shutter speed setting ring will be altered accordingly. The shutter speed setting ring will then pick up the diaphragm setting ring at a different point, and the two will rotate simultaneously in opposite directions.

Lift the shutter speed setting ring straight up to clear the flanged intermediate ring. Next, turn the flanged intermediate ring counterclockwise until its semicircular cutout (figure 46) aligns with the pinion, Fig. 47.

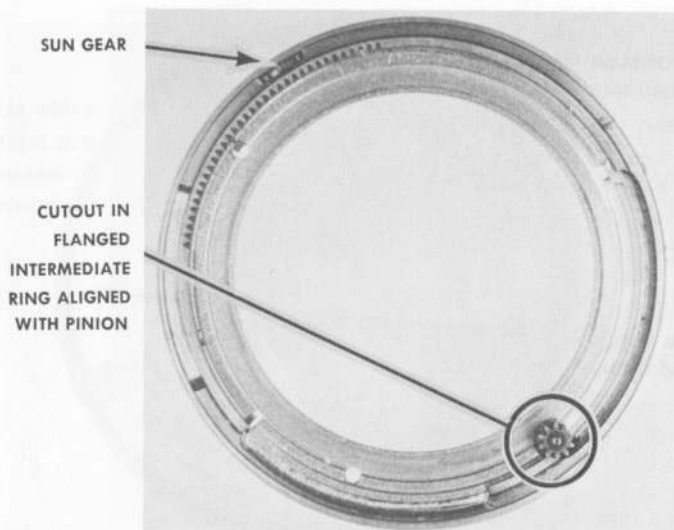

FIGURE 47

In this position, the flanged intermediate ring can be separated from the outer cover plate. Locate the sun gear which now turns freely in either direction, Fig. 48.

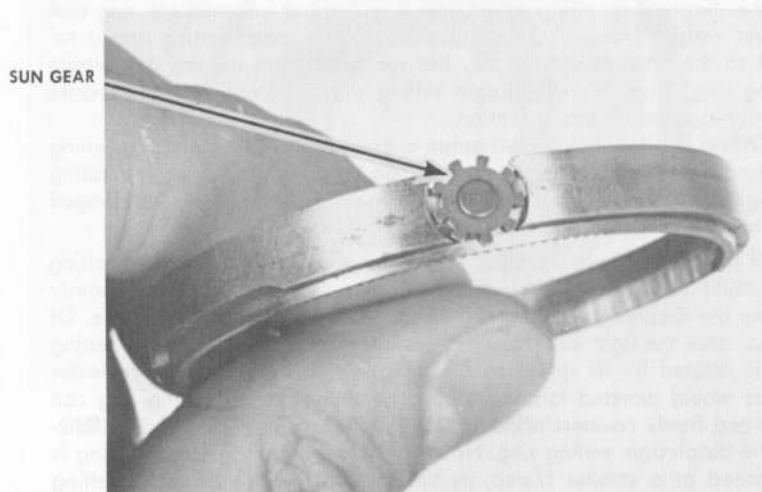

FIGURE 48

You can now see the diaphragm setting ring with its tension-type return spring, Fig. 49. A row of teeth on the diaphragm setting ring (the same shape as those on the shutter speed setting ring) is normally engaged by the sun gear.

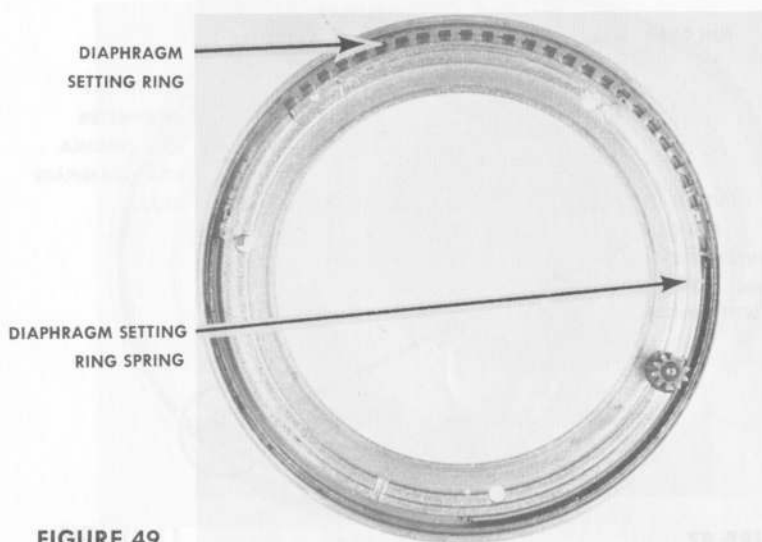

FIGURE 49

Tilt the diaphragm setting ring as you are lifting it out so its tab will clear the slot in the outer cover plate, Fig. 50. (Remember, this tab contacts another tab within the lens to decide how far the diaphragm can stop down.) When the two parts have been separated, the tension spring can be disconnected from the diaphragm setting ring.

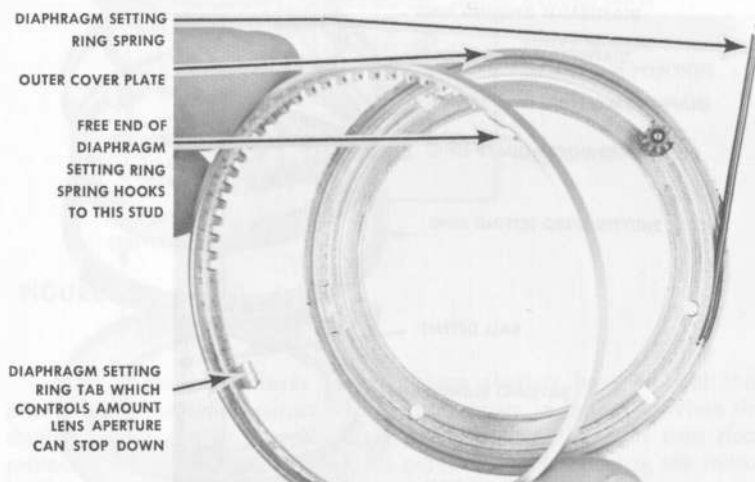

FIGURE 50

REASSEMBLY OF THE LIGHT VALUE MECHANISM

The parts of the light value mechanism can now be safely cleaned if necessary. One of the most convenient cleaning methods is to simply wipe the rings with a dry cloth. This removes any dirt without disturbing the factory lubrication, eliminating the need for relubricating the parts. (The factory uses a dry lubricant which is worked into the pores of the metal.) If the rings are cleaned with solutions, the factory lubrication will be removed. In this case, rub dry moly into the bearing surfaces of the rings—**do not use grease on any part of the light value mechanism.**

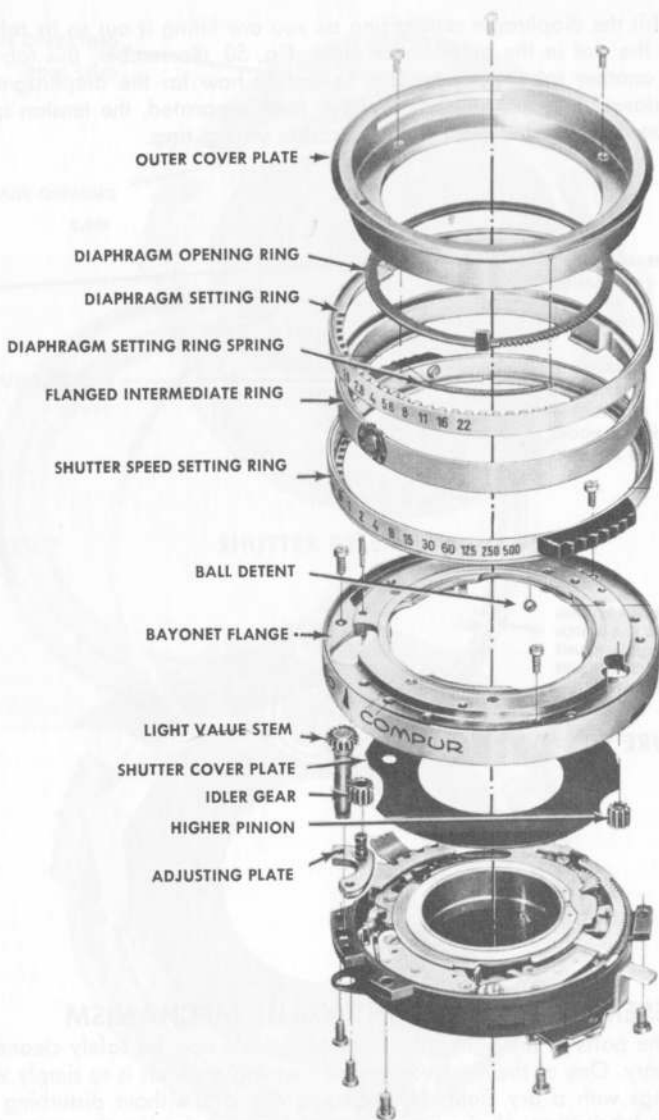

FIGURE 51 EXPLODED VIEW OF LIGHT VALUE MECHANISM

COURTESY FRIEDR. DECKEL

Once the rings have been wiped clean, feed the diaphragm setting ring tab through the slot in the outer cover plate with the tension spring to the inside of the ring, Fig. 52. Before lowering the diaphragm setting ring into place, hook the spring to its stud. Now, seat the diaphragm setting ring while holding the tension spring to the outside of the pinion.



FIGURE 52

To replace the flanged intermediate ring, position its semicircular cut-out adjacent to the pinion on the outer cover plate. When the flanged intermediate ring is fully seated in its track, turn it clockwise until it is blocked by the pinion. Now, rotate the flanged intermediate ring slightly in a counterclockwise direction—**until its vertical stop lug aligns with the locating pin slot in the outer cover plate, Fig. 53.**

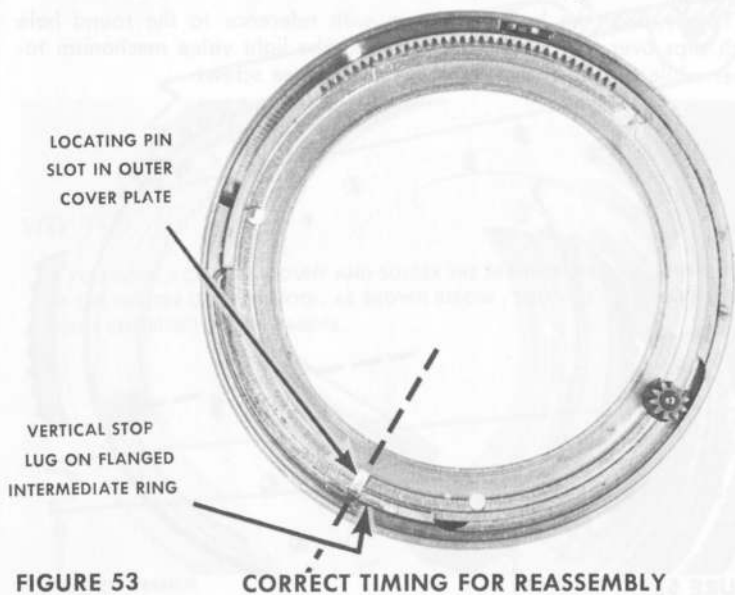

FIGURE 53

CORRECT TIMING FOR REASSEMBLY

Install the diaphragm opening ring with its third gear tooth pointing toward the pinion shaft, Fig. 54. While replacing the shutter speed setting ring, align the "B" calibration with the "1.9" calibration on the diaphragm setting ring.

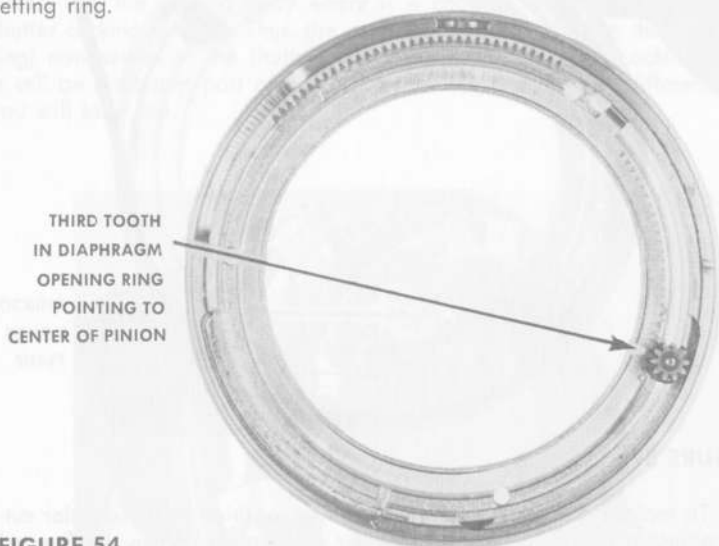

FIGURE 54

As long as these relationships are maintained, the timing of the light value mechanism will be correct. Also, the diaphragm opening ring will be in proper relationship to the corresponding ring in the Quick-Change lens mount.

Finally, seat the bayonet flange with reference to the round hole which slips over the pinion, Fig. 55. Hold the light value mechanism together while turning it over to replace the three screws.



FIGURE 55

After the screws have been tightened, check the assembly to make sure that the timing between the shutter speed setting ring and the diaphragm setting ring is correct. (If this timing was accidentally lost, remove the three screws and lift the outer cover plate just enough to disengage the shutter speed setting ring. Now, turn the shutter speed setting ring in one direction or the other and remesh it with the flanged intermediate ring.)

If the timing is correct, turn the shutter speed setting ring to the "250" calibration on the whole-second scale and release it from this position. The diaphragm setting ring spring should immediately return the parts to "1.9" and "B" with a "snap."

It is essential that the two pinions on the light value mechanism turn freely (these are the pinions that link the shutter's cocking ring to the diaphragm opening ring). Although the pinions may feel free by a manual test, there still could be enough friction to cause a malfunction. After seating the upper pinion over its post on the bayonet flange (its recessed end goes down), place a tiny drop of shutter oil at the top of each pinion/post junction and remove any excess, Fig. 56.

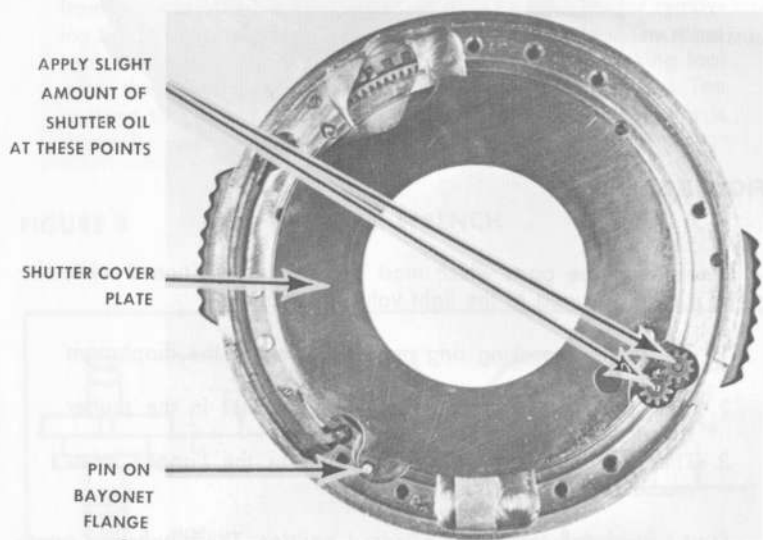

FIGURE 56

Now, place the notched section of the shutter cover plate over the appropriate pin on the bayonet flange, Fig. 56. The black side of the shutter cover plate faces the light value mechanism.

This completes the reassembly of the light value mechanism. You can now seat the idler gear and the light value stem in position on the adjusting plate, Fig. 57. (Note: if the adjusting plate has been removed

and replaced, loosen its two screws slightly and shift the plate as far as it will go toward the outside of the shutter. Tighten the screws while holding the adjusting plate in this position. When the adjusting plate is properly situated, the idler gear will engage both the flanged intermediate ring and the light value stem without sideplay.)

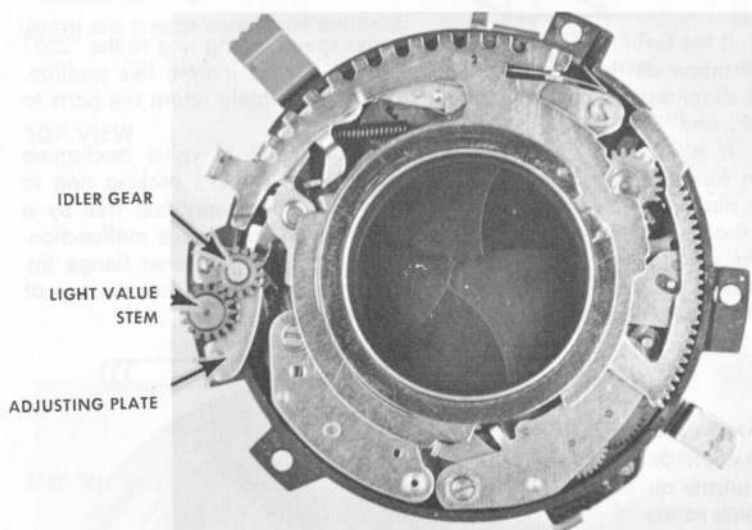

FIGURE 57

There are three parts which must be properly positioned while the shutter is being secured to the light value mechanism:

1. The shutter's cocking ring must be timed to the diaphragm opening ring.
2. The speed cam tab must pass into the slot in the shutter speed setting ring.
3. The light value stem must be timed to the flanged intermediate ring.

Start with the shutter in the released position. The diaphragm opening ring was correctly timed with its pinion during installation. However, if its timing has been accidentally disturbed, rotate the diaphragm opening ring until its tab is a few degrees short of the top of the cutout in the bayonet flange (as shown in figure 9).

Now, position the shutter speed setting ring at "B." With the shutter held vertically, turn the light value stem until its "keyed" surfaces point toward the screw nearest the contact wire on the shutter rear cover plate. That is, an imaginary line midway between and parallel to the two flat sides of the light value stem should pass through the center of the screw, Fig. 58.

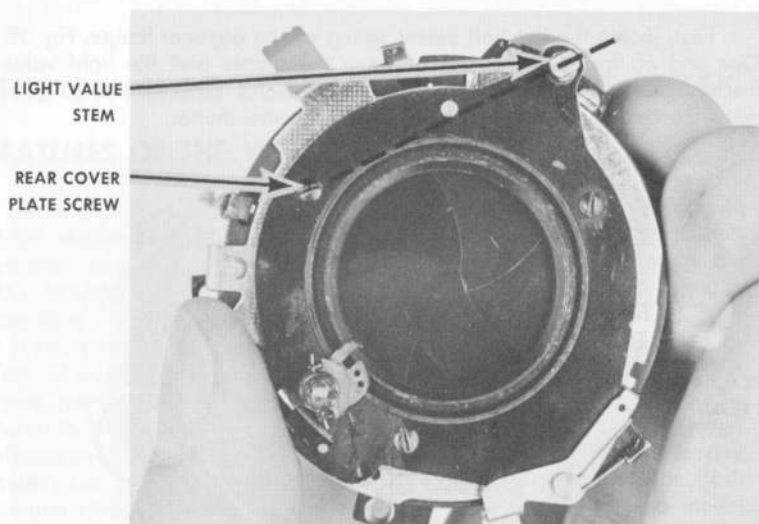

FIGURE 58

Holding both the shutter and the light value mechanism upright, bring the two assemblies together so the idler gear passes into its cutout on the bayonet flange. Next, turn the shutter speed setting ring until the speed cam tab drops into its notch. This allows the shutter to seat fully.

Should the shutter fail to seat properly within the light value mechanism, it is possible that the shutter cover plate is tilted. That is, the shutter cover plate may not be seated evenly around the lens flange. If this is the case, adjust the shutter cover plate's position from the front of the assembly.

With the light value mechanism down against your workbench, turn the shutter speed setting ring to "B" and recheck the position of the light value stem, Fig. 58. If the position has changed, the side of the shutter can be lifted slightly to disengage the gears. This permits you to turn the light value stem. Providing the linkage system in the camera body had not been disturbed, the light value mechanism should now be properly timed to the exposure meter.

Before the screws can be replaced, there is one remaining part which must be installed: the ball detent that provides the "click-stops" for the speed cam in the shutter. The ball detent was not replaced earlier because it is necessary to hold the light value mechanism vertically while aligning the shutter. However, it can now be slipped into place.

First, locate the flat ball detent spring on the bayonet flange, Fig. 59. One end of this spring passes between the shutter and the light value mechanism. This end sits above the cavity which receives the ball detent—the cavity is now hidden from view by the shutter.

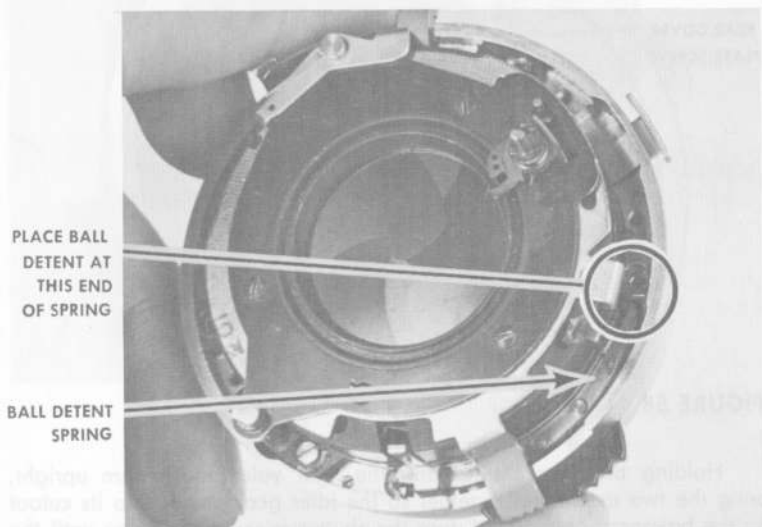

FIGURE 59

Lubricate the ball detent with moly-lube. Next, place it temporarily on the end of its spring which passes under the shutter, the position shown in figure 59. Depress the spring with tweezers and lift the side of the shutter just enough so the ball will pass underneath, into its cavity. Finally, reseal the shutter and test the operation of the shutter speed setting ring—the "click-stops" are assurance that the ball detent is correctly positioned.

Note: The procedure which has just been described requires a certain amount of "feel" and practice. If you find this operation difficult, there is an alternate method you may use. Before fitting the shutter to the light value mechanism, the ball detent may be lubricated with moly-lube and inserted into its cavity. The moly-lube should hold the ball detent in place while you are tilting the light value mechanism to fit it to the shutter. Hold the assembly over your workbench during this operation to prevent losing the ball detent if it should fall out.

When you are certain that all parts are properly assembled, replace the three screws through the shutter mounting lugs. Now, thoroughly check each phase of the operation. Rotate the light value stem to see that it turns easily. By turning only the light value stem, you should be able to set the full range of f/stops (f/1.9 through f/22) and shutter speeds ("B" through 1/500 second).

NATIONAL CAMERA, INC.
Technical Training Division
(National Camera Repair School)