

# PENTAX - H3v

**National Camera**  
**Technical Training Division**



2000 West Union Avenue  
Englewood, Colorado, 80110  
303-789-1893

All rights reserved © Copyright 1974

## THE PENTAX SHUTTER AND MIRROR OPERATION

As one of the most popular of the quality SLR's, the Pentax makes an ideal representative for your first thorough study. Once you understand the operation of this camera, you can apply the theory to other SLR's as well.

From your study of the Leica in an earlier lesson, you are already familiar with the basic shutter operation in the Pentax. There are, however, four primary differences between the focal-plane shutter used in the Pentax and the one previously examined in the Leica IIIf:

1. Since the Pentax is an SLR, the opening curtain is released by the mirror (or by a part that moves with the mirror) rather than by the release plunger. That is, the release plunger trips the mirror which then moves to the taking position under spring tension. At the end of its travel, the mirror releases the opening curtain to initiate the exposure. This sequence assures that the mirror has completely cleared the focal-plane aperture before the opening curtain starts to move.
2. Rather than using the Leica-type curtain drum, the Pentax shutter has two separate winding rollers. In the lesson "Focal-Plane Shutters" you saw how two winding rollers may be used in place of the drum. This is basically the same arrangement employed in the Pentax, and you may wish to review "Focal-Plane Shutters" at this time.
3. In current Pentax models all of the shutter speeds are selected with one speed knob located on the top of the camera. This eliminates the separate slow-speed knob on the front of the camera. The Pentax speed knob controls both the time at which the closing curtain is released and the running time of the escapement.
4. Perhaps the most complex variation between the Pentax and the Leica IIIf also involves the speed knob. In both of the self-capping focal-plane shutters covered in "Focal-Plane Shutters," the speed knob revolves with the opening curtain. You will recall that the speed knob then kicks the closing curtain latch out of engagement according to the shutter speed selected. The Pentax uses a more refined arrangement in which the speed knob does not turn during the cocking and exposure cycles. This is called the non-rotating speed knob, the type most frequently encountered in modern focal-plane shutters.

In this section of the lesson you will examine these variations with the aid of simplified drawings (many of these illustrations are intentionally drawn out of proportion for clarity). Later in this lesson, you will study the disassembly and timing in a current Pentax model.

Notice in figure 1 the close similarity between the Pentax curtain-wind mechanism and the double-winding-roller arrangement you previously studied (compare this illustration with figure 94 in "Focal-Plane Shutters.") The arrows on the drawing in figure 1 show the directions that the gears turn during the cocking cycle.

When the single-stroke rapid wind lever (not shown in the drawing) is actuated to advance the film and cock the shutter, it turns the main wind gear. By referring to figure 1 you can follow the rotation of the main wind gear through the gear train to the curtains. The main wind gear turns the intermediate gear stack, a one-piece gear with upper and lower geared sections. The lower section of the intermediate gear stack engages the lower section of the two-piece clutch gear.

The two sections of the clutch gear are independent of each other. However, during the cocking cycle they are locked together and can turn only in one direction (shown by the arrow above the clutch gear in figure 1). The part which locks the two sections together, making them act as one gear, is the spring-loaded clutch latch. The spring pushes the clutch latch upward, securing the upper section of the clutch gear to the lower section. Thus, the upper section of the clutch gear is driven in the same direction as the lower section during the cocking cycle.

Simultaneously, the upper section of the clutch gear turns the opening curtain wind gear. The opening curtain wind gear, engaged with a pinion on top of the opening curtain winding roller then winds the opening curtain to the cocked position.

During this cycle, the downward-projecting lug on the underside of the opening curtain wind gear comes against the horizontal lug on the top of the closing curtain wind gear. Thus, the closing curtain wind gear is turned in the same direction. This pulls the closing curtain across the focal plane and wraps it around the closing curtain winding roller. As they travel from right to left (looking at the front of the camera) to the cocked position, the two curtains overlap by one bar width to prevent exposure of the film.

If the pressure is relaxed from the wind lever before the shutter is fully cocked, the clutch gear prevents the take-up rollers from pulling their curtains in the release direction. The lower section of the clutch gear never turns opposite the arrow shown in figure 1 (the wind shaft gear, which is under the main wind gear and is not shown here, is turned by the lower section of the clutch gear — the wind shaft contains a one-way clutch that prevents reverse rotation). Since the upper section of the clutch gear is locked to the lower section by the clutch latch, it is at this time unable to rotate in the release direction.

At the end of the cocking cycle, the spring-loaded opening curtain latch engages the lug on the underside of the opening curtain wind gear. The shutter is now fully cocked: the curtains are at the left end of the focal-plane aperture and the springs inside the take-up rollers are tensioned.

The curtains are now held against the tensions of the take-up rollers at two places: by the opening curtain latch and by the clutch gear. Before the opening curtain can be released to initiate the exposure, two actions must occur: the opening curtain latch must be disengaged from the opening curtain wind gear and the upper section of the clutch gear must be freed from the lower section. Since the opening curtain is unable to move from right to left, the closing curtain is also held. This is because the horizontal lug on top of the closing curtain wind gear is still in contact with the lug on the underside of the opening curtain wind gear.

To release the shutter, the clutch latch is first depressed against its spring tension to free the upper section of the clutch gear. This is necessary because the upper section of the clutch gear always revolves with the opening curtain wind gear — while the lower section never turns in a clockwise direction. However, until the curtains are fully wound it is impossible to depress the clutch latch and accidentally release the shutter. The clutch cam, under the clutch gear, has a cutout which will only align with the bottom of the clutch latch in the fully-cocked position.

If you attempt to release the shutter when the curtains are part way across the focal plane, the bottom of the clutch latch will strike the solid ridge of the clutch cam. This prevents the clutch latch from moving down to free the upper section of the clutch gear. Consequently, the two sections of the clutch gear cannot be separated until the clutch gear has rotated far enough to bring its latch over the cutout in the clutch cam.

Consider now that the shutter is fully cocked. The clutch latch is over the cutout in the clutch cam and the opening curtain wind gear is held by the opening curtain latch. When the release plunger is depressed to make the exposure, it pushes the clutch latch down into the cutout in the clutch cam to free the upper section of the clutch gear, Fig. 2. (Although the release plunger is not shown in this drawing, it is indicated by the heavy arrow in figure 2.)

The upper section of the clutch gear is now free to turn in the release direction, while the lower section remains stationary. However, the curtains cannot yet travel across the focal plane to make the exposure. This is because the opening curtain wind gear is still held by the opening curtain latch.

Remember, the release plunger freed the upper section of the clutch gear when it was first depressed. At the end of its downward travel, the release plunger trips the reflex mirror. This action is diagrammed in figure 3. Notice that a horizontal section of the release plunger depresses the clutch latch. Then, the release rod at the bottom of the release plunger trips the mirror release lever.

Now, the spring-loaded reflex mirror moves upward to the taking position. When it clears the focal-plane aperture, the mirror bracket kicks the opening curtain latch out of engagement with the opening curtain wind gear, Fig. 2.

The clutch latch is still held disengaged by the release plunger. Thus, tripping the opening curtain latch allows the opening curtain take-up roller to pull its curtain across the focal-plane aperture. As it travels, the opening curtain turns the opening curtain wind gear and the upper section of the clutch gear (in the directions of their arrows in figure 2).

The important point here is that the mirror is released and reaches the taking position before the opening curtain begins its travel. It is essential that the mirror is completely clear of the focal-plane aperture before the opening curtains starts its movement to expose the film.

Once the opening curtain wind gear begins its release (counterclockwise) rotation, it frees the closing curtain wind gear. You know, however, that the closing curtain must be restrained after the opening curtain has been released to provide a slit. As in other self-capping, focal-plane shutters you have studied, this action is provided by the closing curtain latch.

When the release plunger was first depressed, it allowed the spring-loaded closing curtain latch to move toward the closing curtain wind gear. Here, the closing curtain latch is in position to intercept a counterclockwise rotation of the closing curtain wind gear, Fig. 2. Before the closing curtain can enter the focal-plane aperture, the closing curtain latch must be disengaged.

If the shutter is set to "bulb," the closing curtain is restrained by the closing curtain latch for as long as the release plunger is held depressed. When the release plunger is allowed to return, it pulls the closing curtain latch out of engagement to free the closing curtain.

This action of the closing curtain latch is more clearly seen in figure 3. Notice that the lower leg of the closing curtain latch is against the release plunger shaft. This holds the closing curtain latch against its spring tension, away from the closing curtain wind gear.

As the release plunger moves down, the lower leg of the closing curtain latch drops into the tapered groove around the release plunger shaft. Consequently, the closing curtain latch is allowed to move toward the closing curtain wind gear.

On instantaneous speeds, the closing curtain latch is kicked out of engagement at some point during the opening curtain's travel (before the release plunger is allowed to return). This action is similar to other focal-plane shutters you have studied; that is, the opening curtain in effect releases the closing curtain according to the distance it has moved. The sooner the closing curtain latch is disengaged, the smaller will be the slit width and the faster the resulting shutter speed.

As you will recall, in the Leica IIIf, a pin on the underside of the speed knob kicks the closing curtain latch aside during the opening curtain's travel. This requires a rotating speed knob, one which turns as the opening curtain moves across the focal-plane aperture. Since the Pentax has a non-rotating speed knob, a slightly different arrangement is used. Although the principle is the same, a few more parts are added to the speed knob.

In this design, the release cam (rather than a pin on the speed knob) disengages the closing curtain latch, Fig. 4. A slot in the release cam fits over a pin on the top of the opening curtain wind gear. Thus, as the opening curtain wind gear rotates it carries the release cam in the same direction.

For example, assume that the shutter has just been released and the opening curtain has started its travel across the focal plane. The closing curtain, held by the closing curtain latch, cannot as yet follow the opening curtain. Now as the opening curtain is moving from left to right, the opening curtain wind gear and the release cam both revolve in a counterclockwise direction. Finally, after a predetermined amount of opening curtain travel the release cam strikes the upper finger of the closing curtain latch, Fig. 4. This frees the closing curtain which follows the opening curtain at the proper distance.

From this, it may at first appear as though there is no way to change the slit width. However, the loose fit of the release cam slot over the opening curtain wind gear pin does permit adjustment. Because of this play, the position of the release cam may be altered with respect to the closing curtain latch to change the slit width.

The position of the release cam is determined by the eccentric shaft, Fig. 4. The lower shoulder of the eccentric shaft passes through the center of the release cam. It is this shoulder that is shaped eccentrically.

When the shutter speed is selected, the eccentric shaft is rotated within the release cam. This moves the release cam accordingly, fixing its position above the opening curtain wind gear. Now, as the opening curtain travels across the focal plane during the exposure cycle the release cam turns around the eccentric shaft. The rotational position of the eccentric shaft determines the arc the release cam will take as it travels — and thereby the time at which the release cam will strike the closing curtain latch. The eccentric shaft itself remains in a fixed position during the exposure cycle, turning only when the shutter speeds are changed.

A cutout on the side of the eccentric shaft receives a downward-projecting tab on the underside of the speed cam. The speed cam is secured to the underside of the speed knob, Fig. 4. Thus, when the speed knob is turned to select a shutter speed it changes the rotational position of the eccentric shaft through the speed cam.

Remember, the only time the speed knob, the speed cam, and the eccentric shaft turn is when the shutter speed is selected. This determines the rotational position of the eccentric shaft which then decides the arc the release cam will take as it travels. During the shutter operation — both during the exposure and cocking cycles — the speed knob, the speed cam, and the eccentric shaft remain stationary.

Providing the release cam is at the same level as the closing curtain latch, it will free the closing curtain at some point during its travel. On "bulb" action, however, the closing curtain latch must remain engaged with the closing curtain wind gear as long as the release plunger is held down. To prevent the release cam from striking the closing curtain latch on "bulb," the release cam is raised above the plane of the closing curtain latch. This is the function of the eccentric cam shown in figure 4.

Whereas the speed cam determines the rotational position of the eccentric shaft, the eccentric cam determines its vertical plane. The eccentric cam itself always remains fixed in one position.

Notice the single "tooth" on the underside of the eccentric cam. This tooth is keyed to a corresponding V-shaped notch on the top of the eccentric shaft. Since the eccentric cam never moves, its tooth remains at one fixed position. However, the eccentric shaft rotates when the shutter speeds are changed; hence, its notch may or may not align with the tooth.

The eccentric shaft and the release cam are actually held together as one unit by the retaining ring shown in figure 4. Thus, as the eccentric shaft is moved up or down vertically the release cam is moved in the same direction. The release cam is still free to spin around the eccentric shaft during the shutter operation.

Since there is only one tooth on the eccentric cam, and just one V-shaped notch in the eccentric shaft, the tooth corresponds to one shutter speed setting. This is the "bulb" setting, the only position at which the tooth and the notch will align. At all of the remaining speeds, the tooth rides against the solid ridge on the top of the eccentric shaft.

A compression spring (not shown in the illustration) tends to hold the eccentric shaft up against the eccentric cam tooth. If the speed knob is set at an instantaneous exposure or "time," the tooth on the eccentric cam is against the ridge on the top of the eccentric shaft. This pushes the eccentric shaft down, against the tension of the compression spring. In this position, the release cam is at the same level as the closing curtain latch. Then, when the shutter is released the release cam will strike the closing curtain latch in the manner previously discussed.

However, if the speed knob is set to "bulb," the tooth on the eccentric cam will align with the notch in the eccentric shaft. This allows the compression spring to push the eccentric shaft upward, against the eccentric cam. As the eccentric shaft moves up, it carries the release cam above the level of the closing curtain latch. Now, when the shutter is tripped the release cam will travel over the top of the closing curtain latch. The closing curtain latch will thus remain engaged with the closing curtain wind gear until the release plunger is allowed to return to its rest position.

You have seen how the position of the speed knob determines the slit width. Since the slow speeds, as well as the fast and intermediate speeds, are set on the same knob, the speed knob also controls the escapement running time. That is, the single speed knob in the Pentax performs the functions of both the speed knob and the slow-speed knob in the Leica IIIf which you previously studied.

While its downward-projecting tab is used to select the slit width, the outer edge of the speed cam determines the escapement running time. The upper retard lever rides against the edge of the speed cam, Fig. 4. A long rod connects the upper retard lever to the lower retard lever and the escapement at the bottom of the camera, Fig. 5. The spring on the lower retard lever holds the upper retard lever in firm contact with the edge of the speed cam.

As you know, slow speeds may be provided by restraining the closing curtain with a retard mechanism after the opening curtain has completely crossed the focal-plane aperture. In the Pentax, the connection between the closing curtain and the escapement is through the closing curtain control gear which engages a pinion on the bottom of the closing curtain winding roller, Fig. 1. As the closing curtain winding roller turns, it drives the closing curtain control gear.

When the shutter is set to a long exposure the lower retard lever is moved toward the escapement. This brings the lower retard lever in position to contact a pin on the closing curtain control gear. The speed cam determines the depth that the lower retard lever engages the first gear segment in the escapement, Fig. 5.

Consider now that the shutter has been released and the opening curtain has completely crossed the focal-plane aperture. Here, the opening curtain releases the closing curtain. However, before the closing curtain can enter the aperture the pin on the closing curtain control gear is intercepted by the lower retard lever. This restrains the closing curtain while the closing curtain control gear turns against the escapement.

"Time" action is obtained by locking the lower retard lever with a time latch (not shown here). With the lower retard lever held in place, the closing curtain control gear cannot swing it aside. Thus, the focal-plane aperture is held open until another shutter speed is selected. This moves the lower retard lever back, free of the time latch. You will see the time latch during your study of the actual camera disassembly later in this text.

Besides its operation during the slow speeds, the closing curtain control gear has another function in the camera. This involves the control of the reflex mirror operating mechanism. After the closing curtain has crossed the focal plane to end the exposure, the closing curtain control gear trips a latch which allows the mirror to return to the viewing position. You will see how this is done during the Pentax disassembly. For now, remember that the mirror trips the opening curtain, assuring that the focal plane is uncovered before the exposure is initiated. Then, the closing curtain allows the mirror to return to the viewing position, assuring that the exposure has ended before the mirror is again allowed to enter the light path.

As you have seen, there are only a few minor variations between the Pentax shutter and the shutter in the Leica IIIIf. The most apparent of these variations result from the use of a reflex mirror which must be correlated to the shutter operation. Before proceeding to the Pentax disassembly, you should have a basic idea of how the mirror operates and how it is timed to the shutter curtains. There are two basic mirror designs which differ only slightly in the different Pentax models. We shall examine one design now and another later in the text.

The Pentax uses a rapid return mirror. This means that the mirror returns instantly to the viewing position after the closing curtain has ended the exposure. The parts of the mirror operating mechanism, Fig. 6, have two purposes: to raise the mirror to the taking position when the release plunger is depressed; and to lower the mirror to the viewing position after the exposure is ended.

During the cocking cycle, the mirror tensioning lever, Fig. 6, is moved toward the rear of the camera. (This is done through a link to the wind mechanism which you will later see.) As the mirror tensioning lever travels in the direction of arrow #1 in figure 6, it tensions both the return spring and the mirror lifting spring. At the end of the cocking cycle, the mirror tensioning lever is latched in position toward the rear of the camera.

The tension-type mirror lifting spring hooks at one end to the mirror tensioning lever and at the other end to the mirror lifting lever. When this spring is tensioned by the mirror tensioning lever, it attempts to pull the mirror lifting lever in the direction of arrow #2. Now the forked end of the mirror lifting lever straddles a pin on the mirror bracket. Thus, this movement tends to raise the mirror to the taking position (in the direction of arrow #3). Of course, the mirror must not be raised until the camera release is depressed. Therefore, the mirror release lever (shown in figures 3 & 6) holds the mirror in the viewing position, against the tension of the mirror lifting spring.

Remember, when the release plunger is depressed it pushes the mirror release lever out of engagement with the mirror bracket. Now, the mirror lifting spring pulls the mirror lifting lever in the direction of arrow #2, raising the mirror to the taking position. Once it clears the focal-plane aperture, the mirror bracket contacts the striker, Fig. 6. The striker is the part which actually kicks the opening curtain latch out of engagement with the opening curtain wind gear.

The mirror must remain in the taking position the entire period that the curtains are in motion. Therefore, the mirror tensioning lever is held toward the rear of the camera until the closing curtain has crossed the focal plane and sealed off the film. Then, the closing curtain control gear kicks a latch out of engagement with the mirror tensioning lever. This allows the return spring, Fig. 6, to move the mirror tensioning lever toward the front of the camera. As it returns, the mirror tensioning lever contacts the mirror lifting lever to bring the mirror back to the viewing position. Then, the mirror is once again latched by the mirror release lever.

(Note: this sketch has been drawn out of proportion for clarity both curtains are actually the same size.)

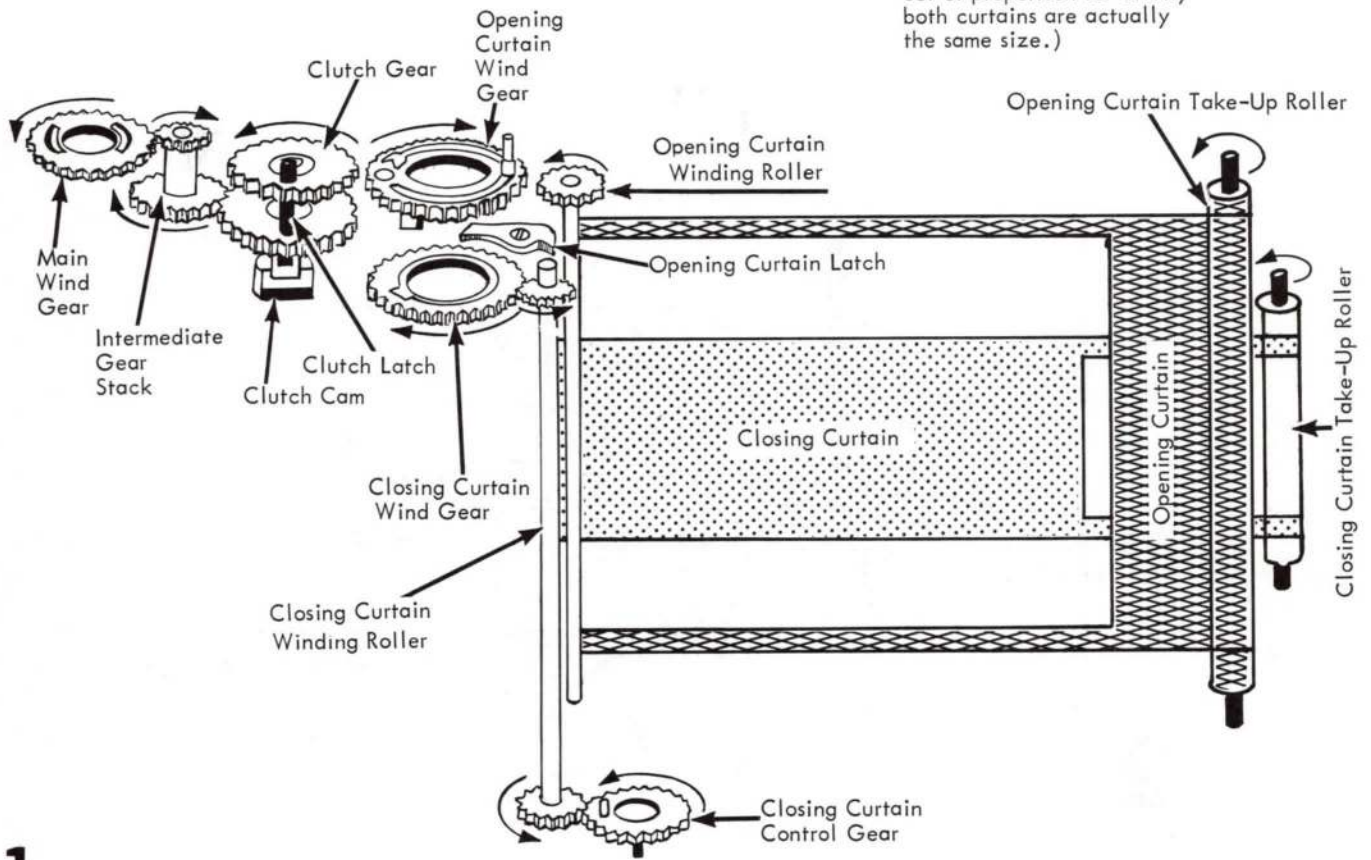

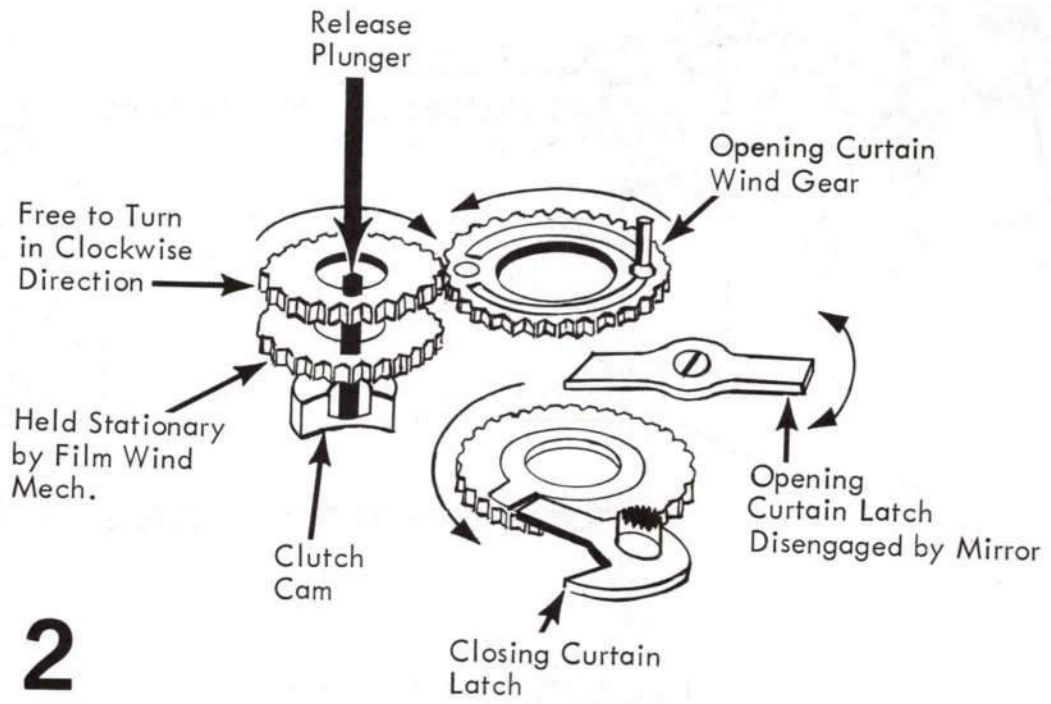

2

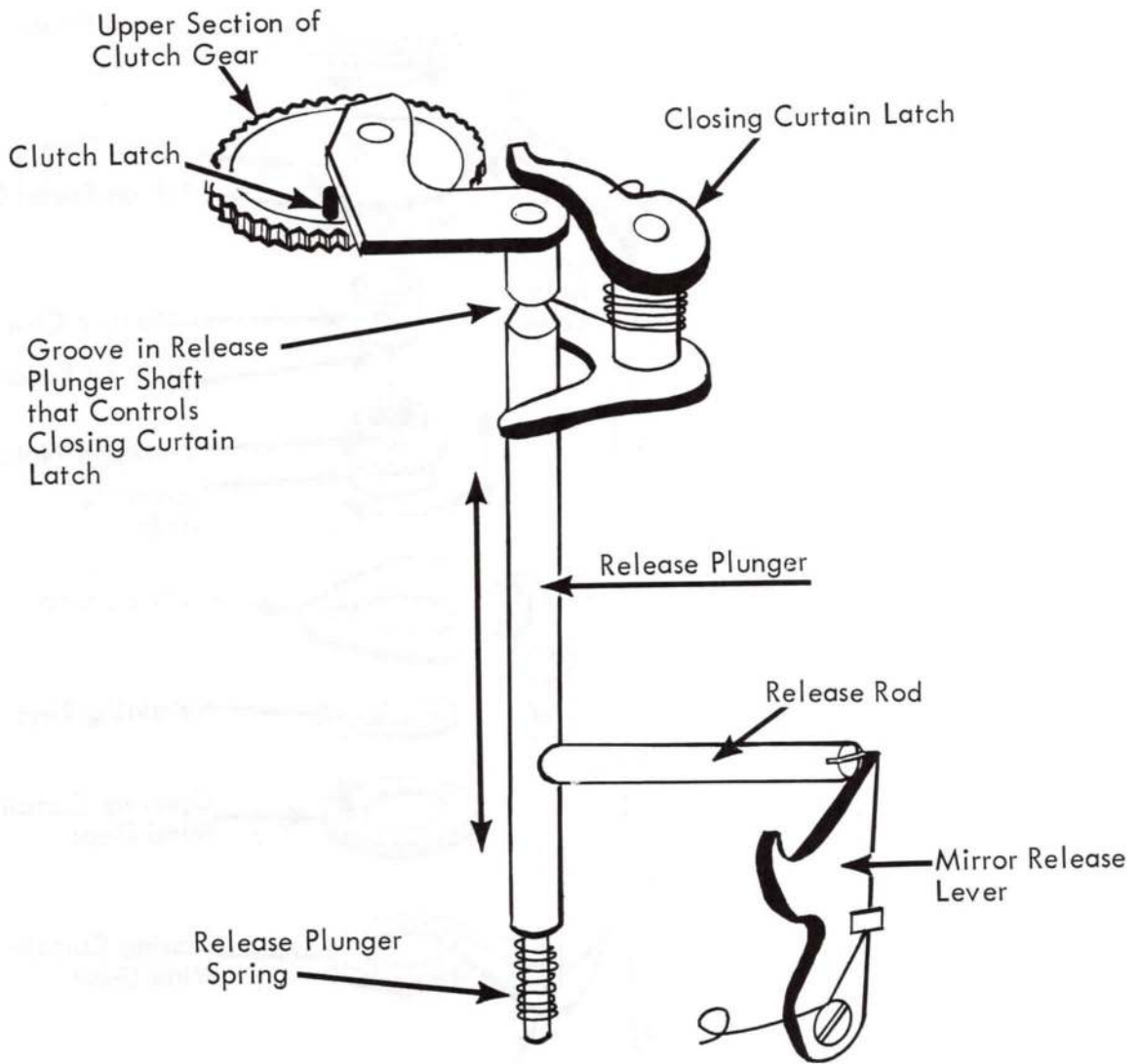

3

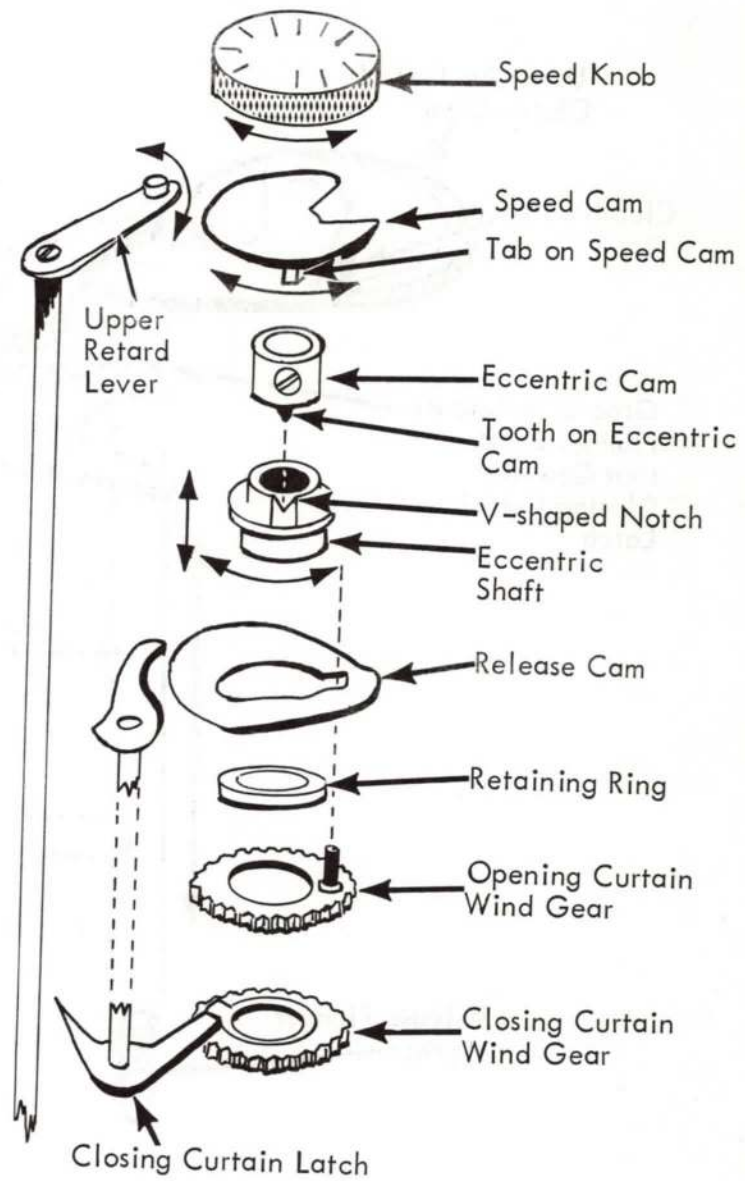

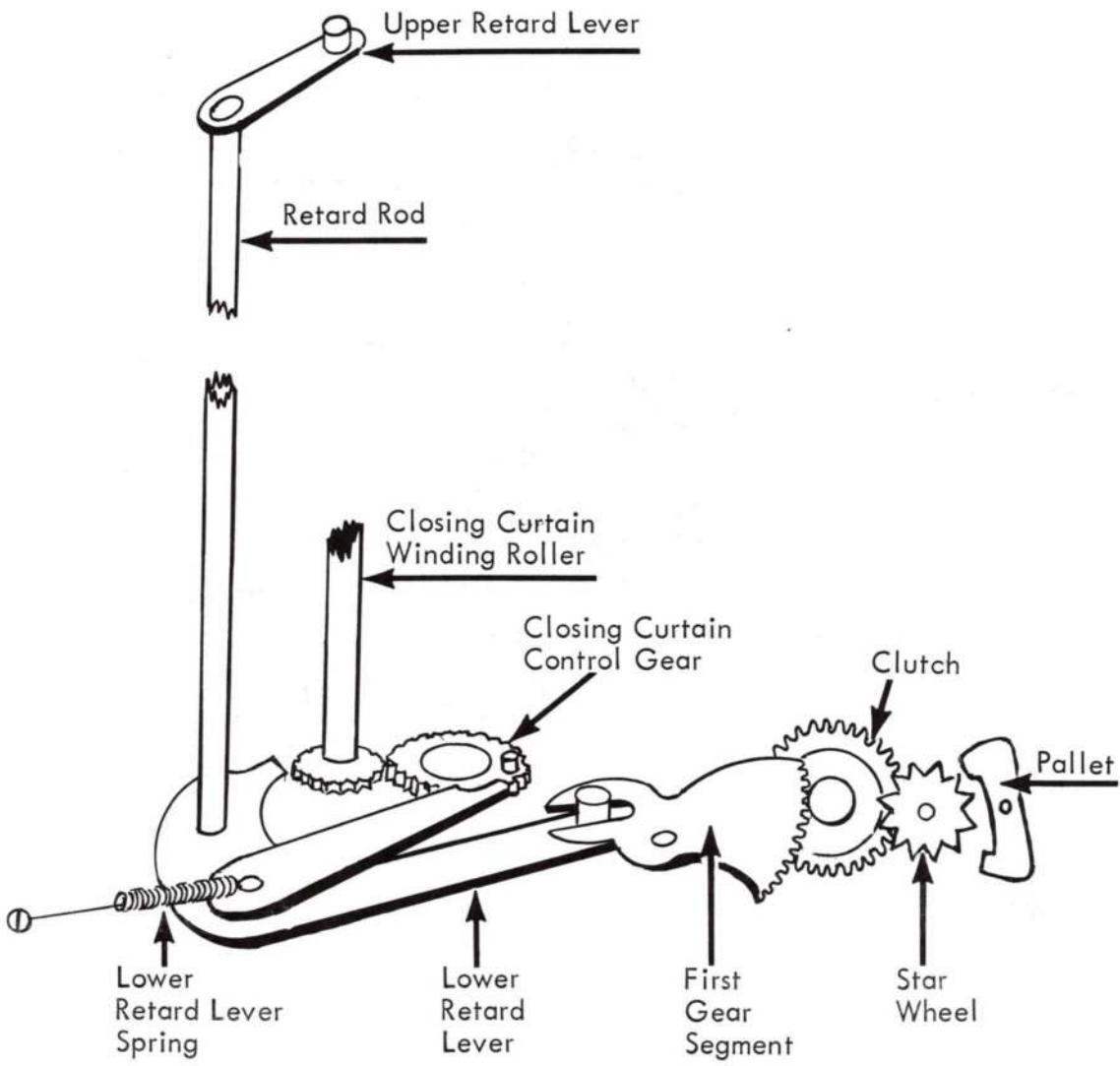

5

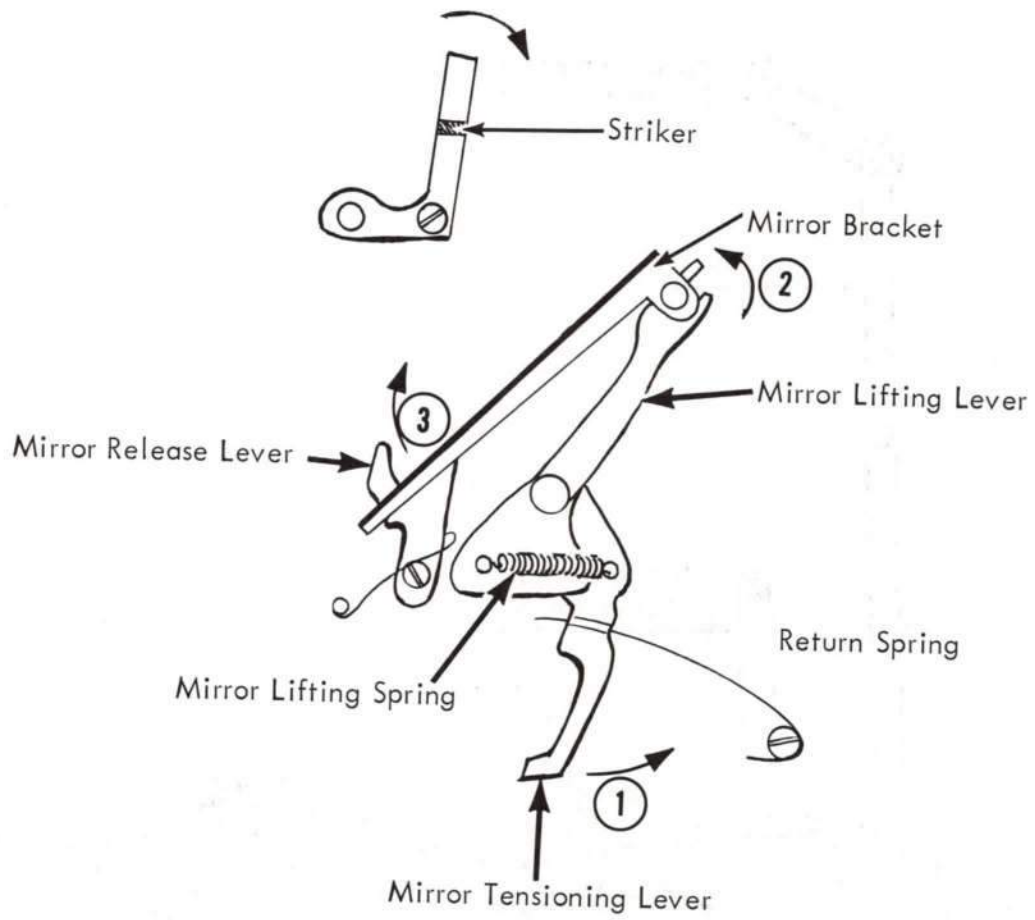

6



7

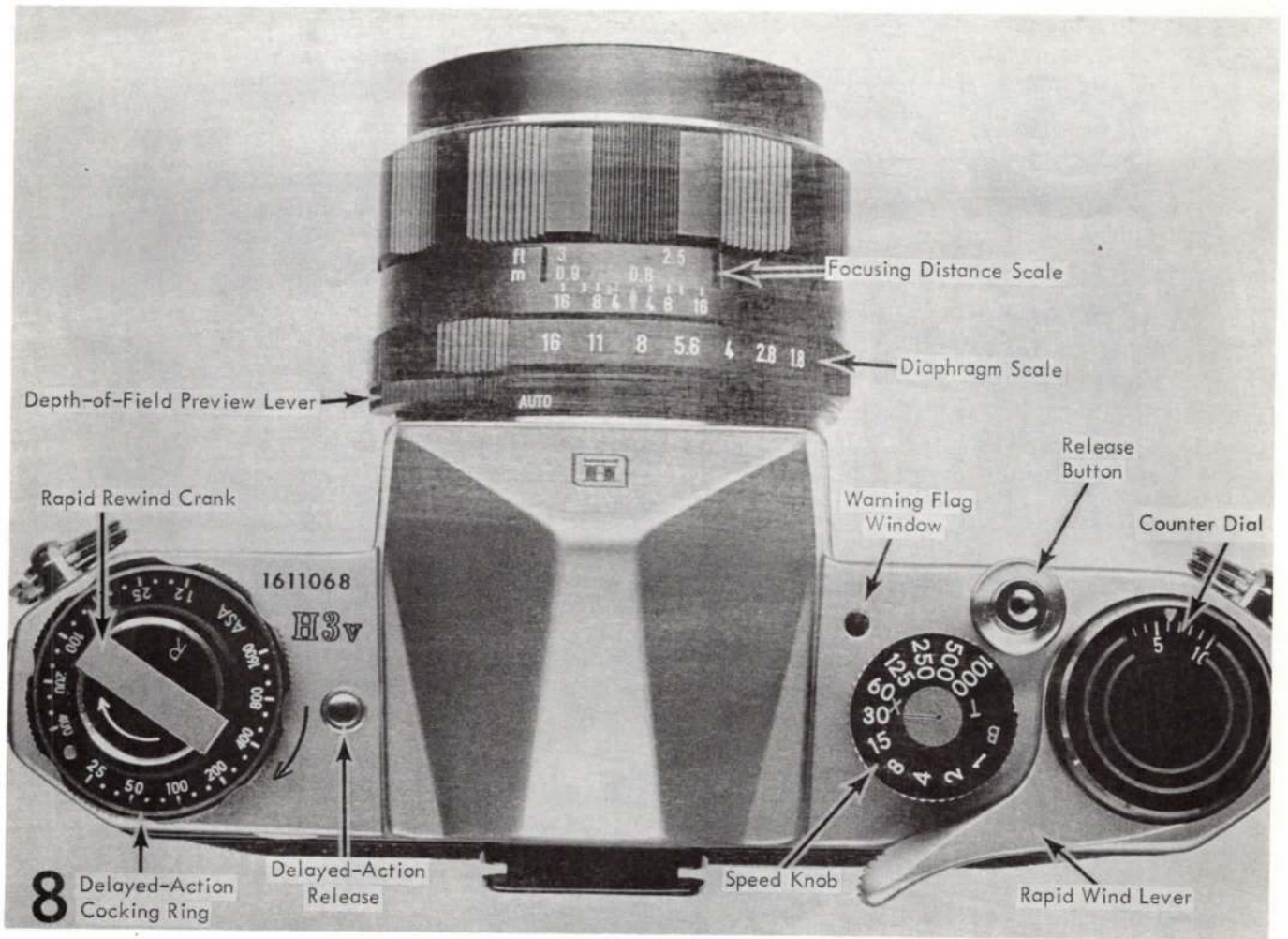

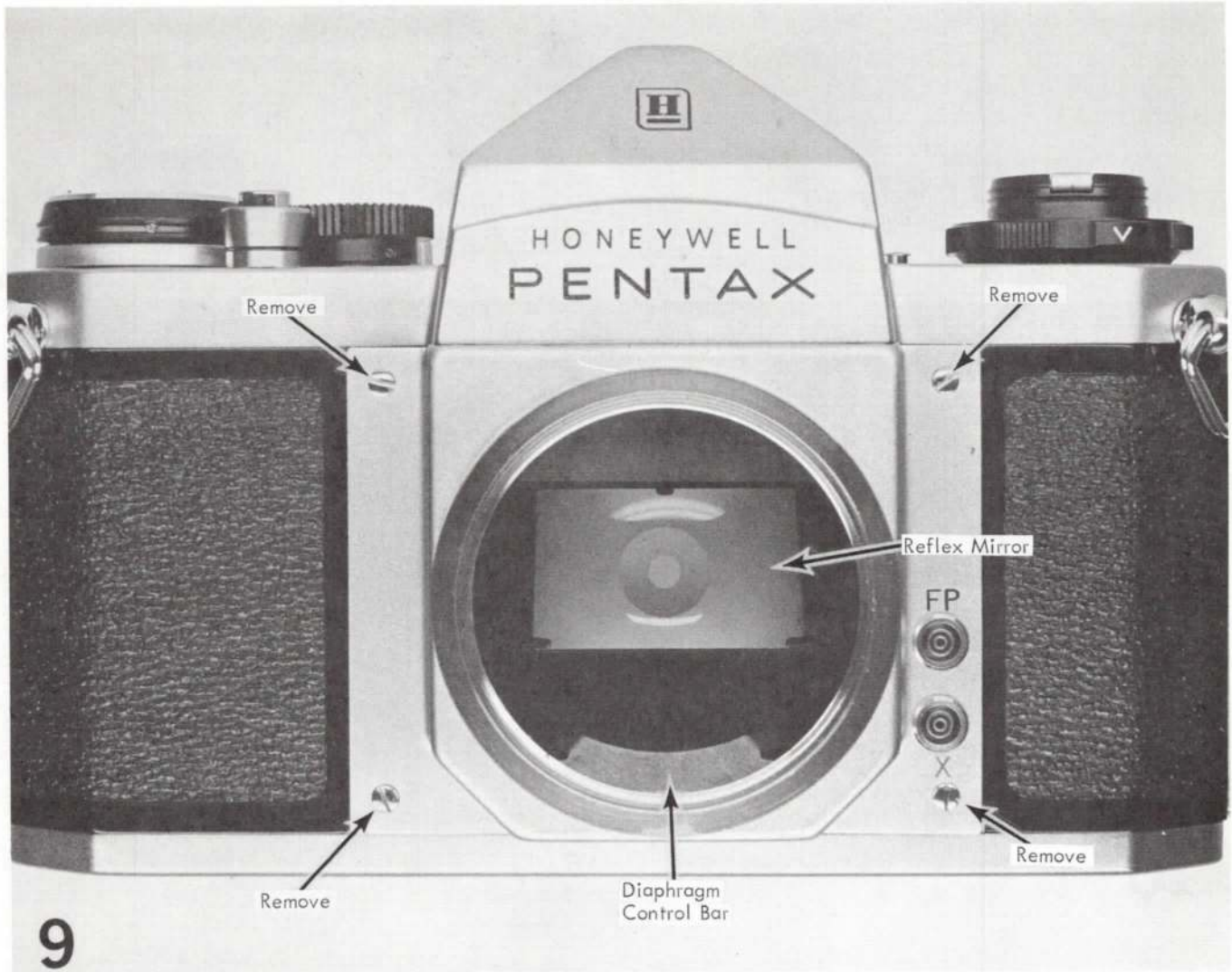

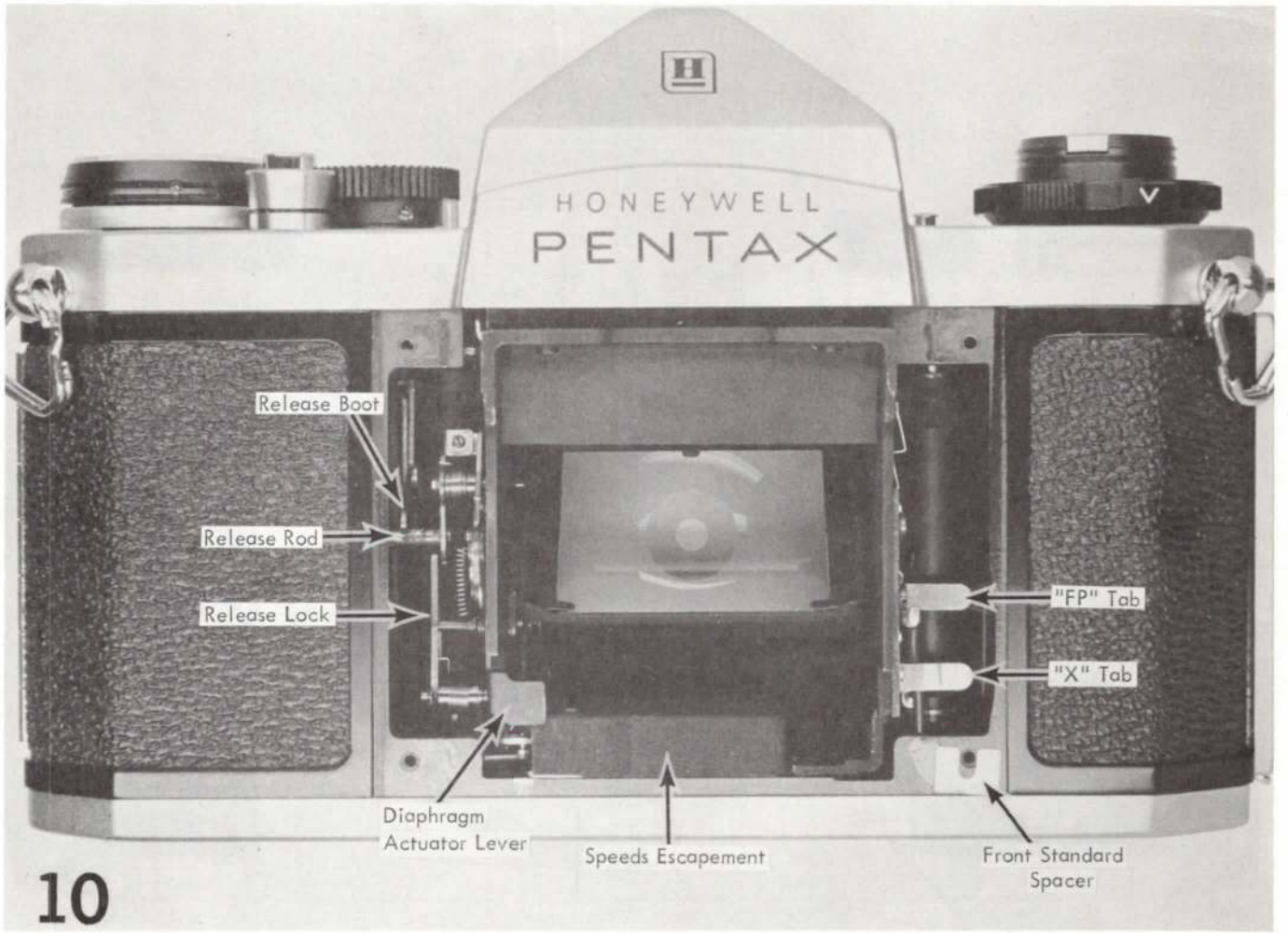

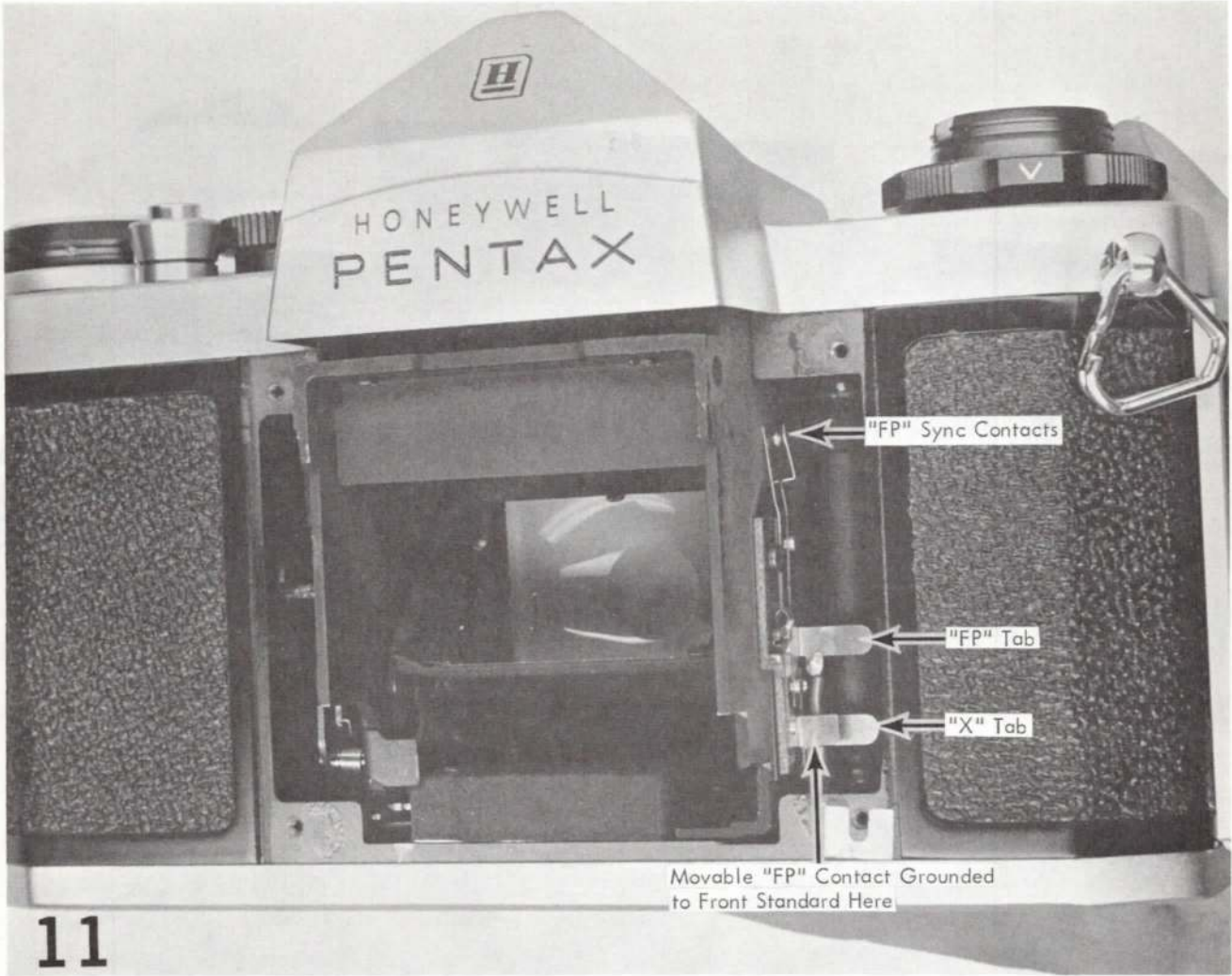

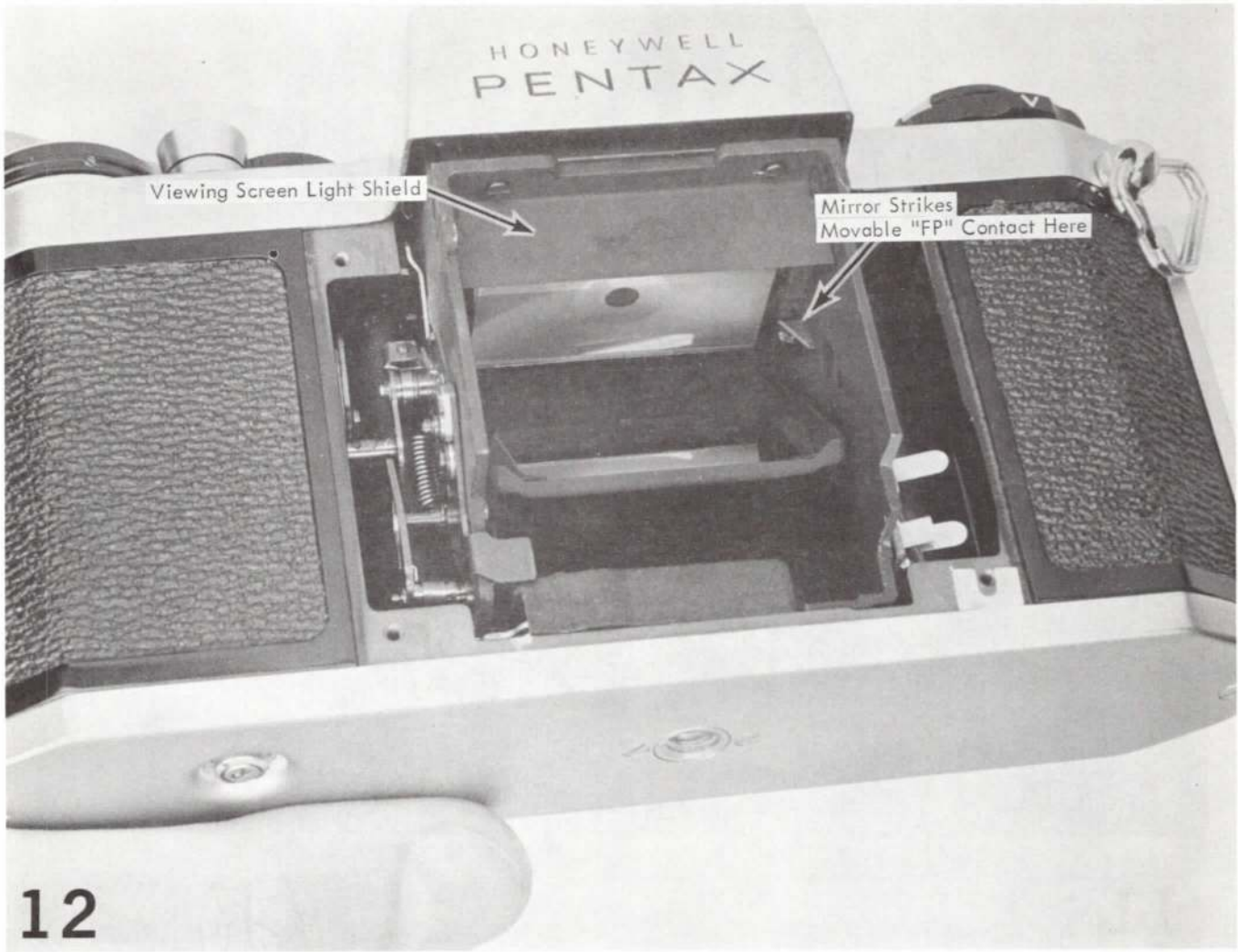

HONEYWELL  
PENTAX

Viewing Screen Light Shield

Mirror Strikes  
Movable "FP" Contact Here

12

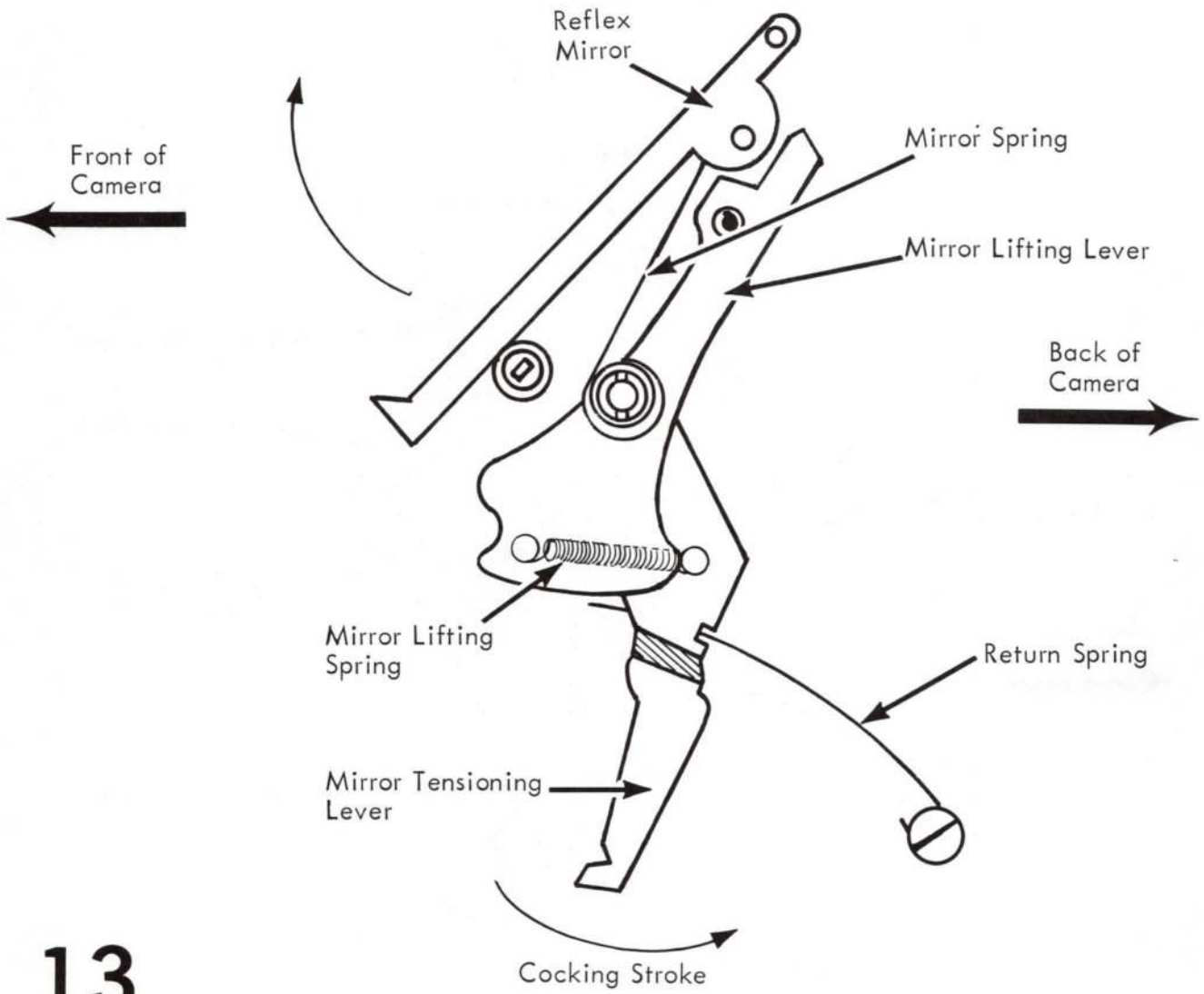

13

(From Inside of Mirror Housing)

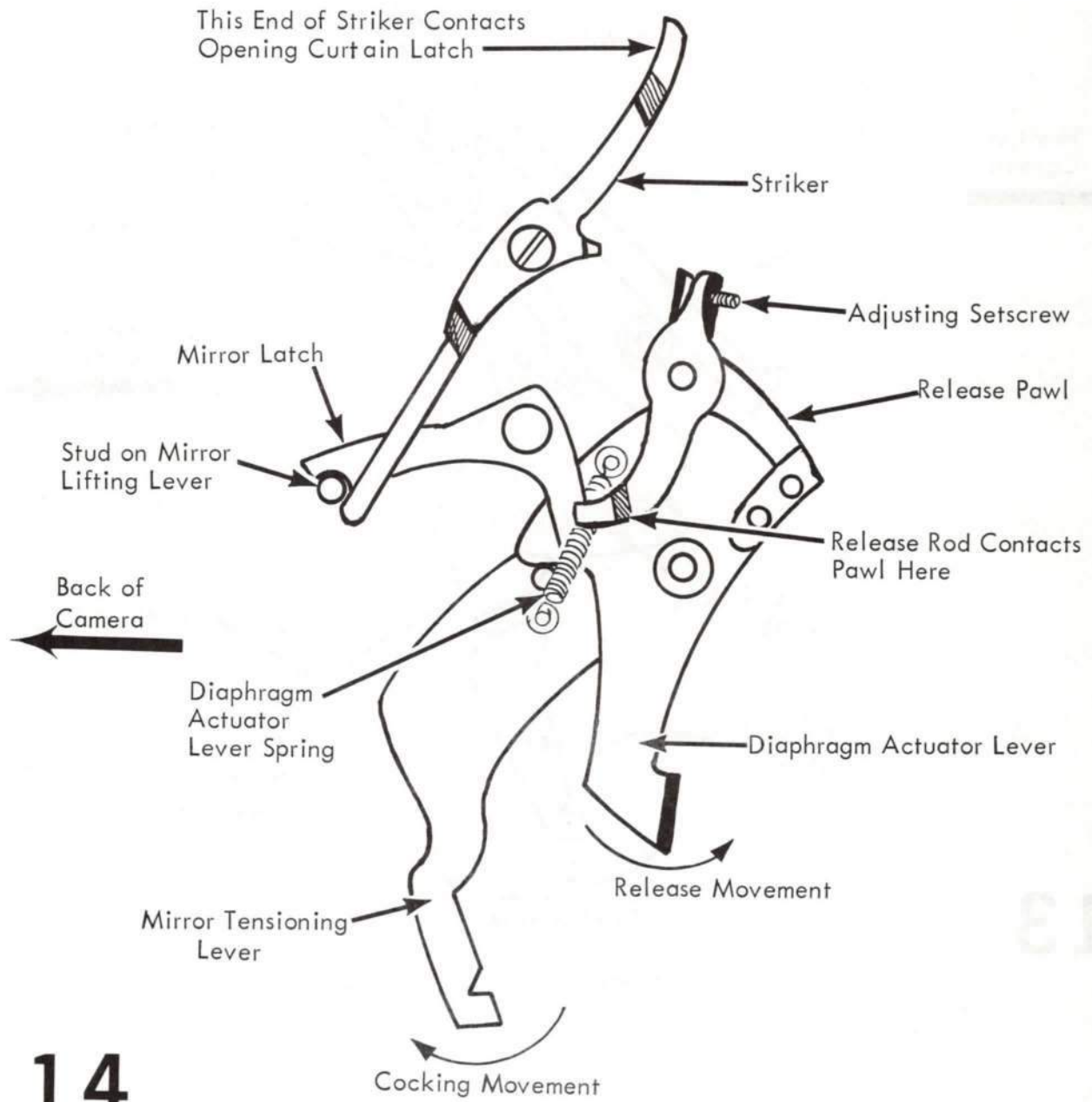

14

(From Outside of Mirror Housing)

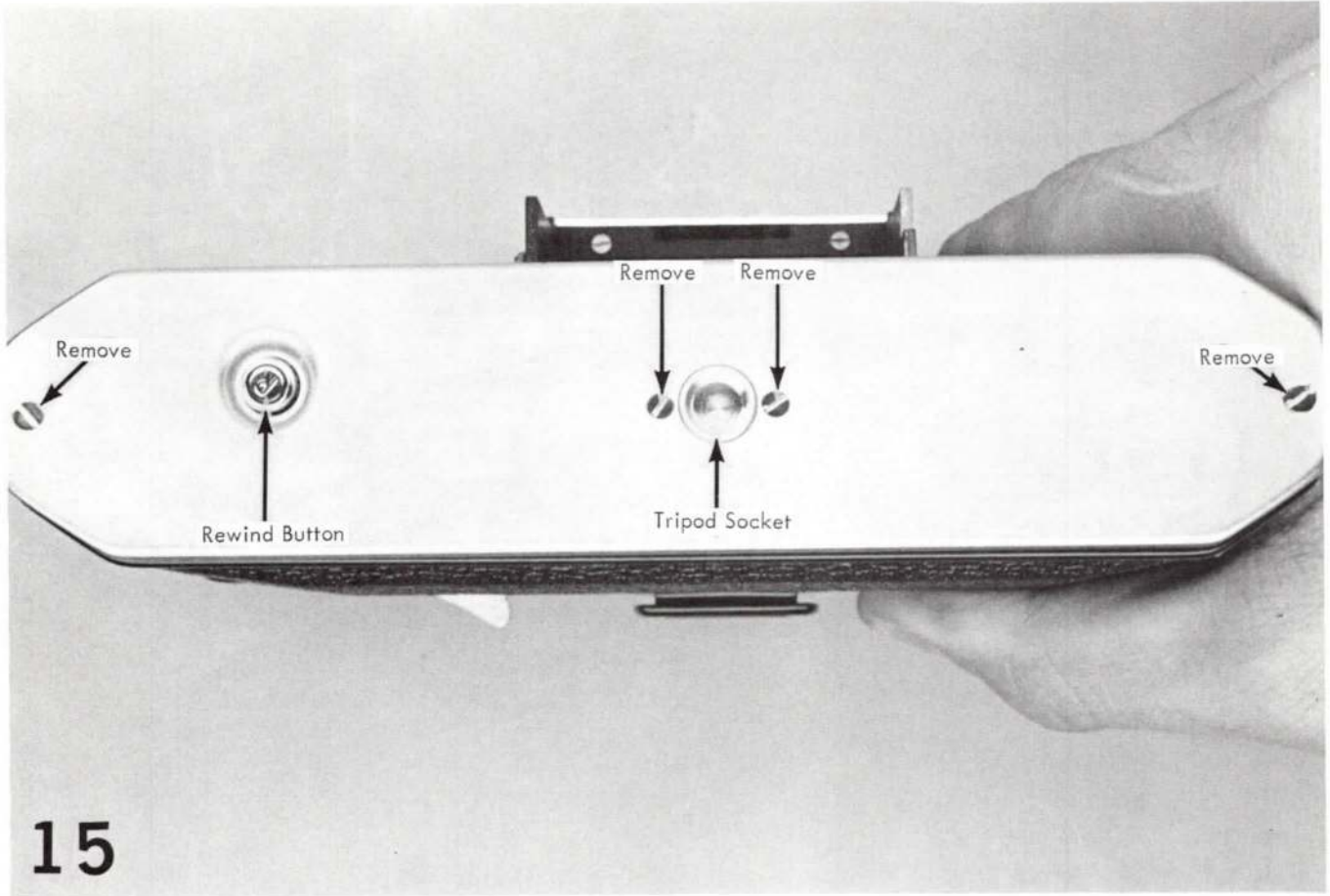

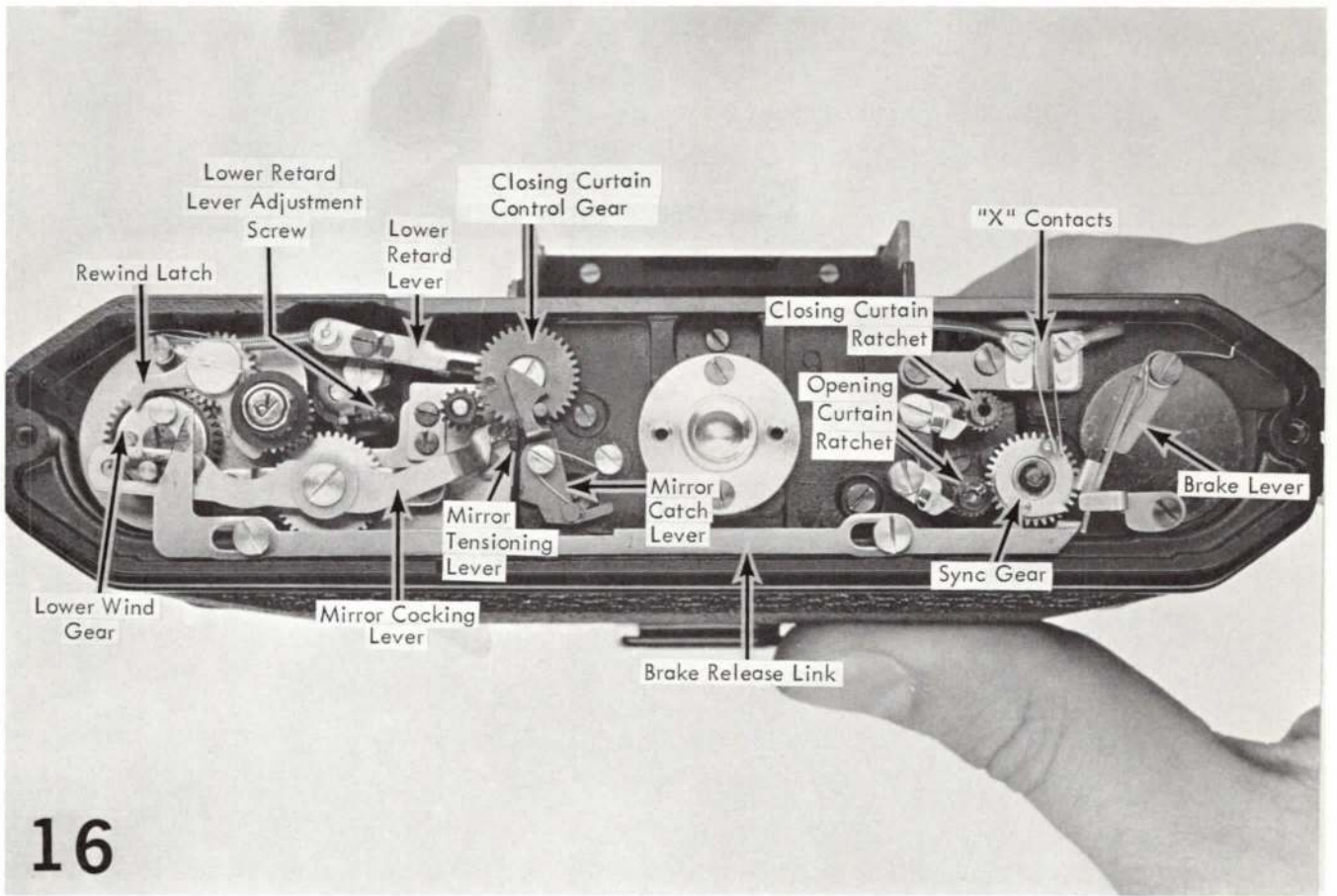

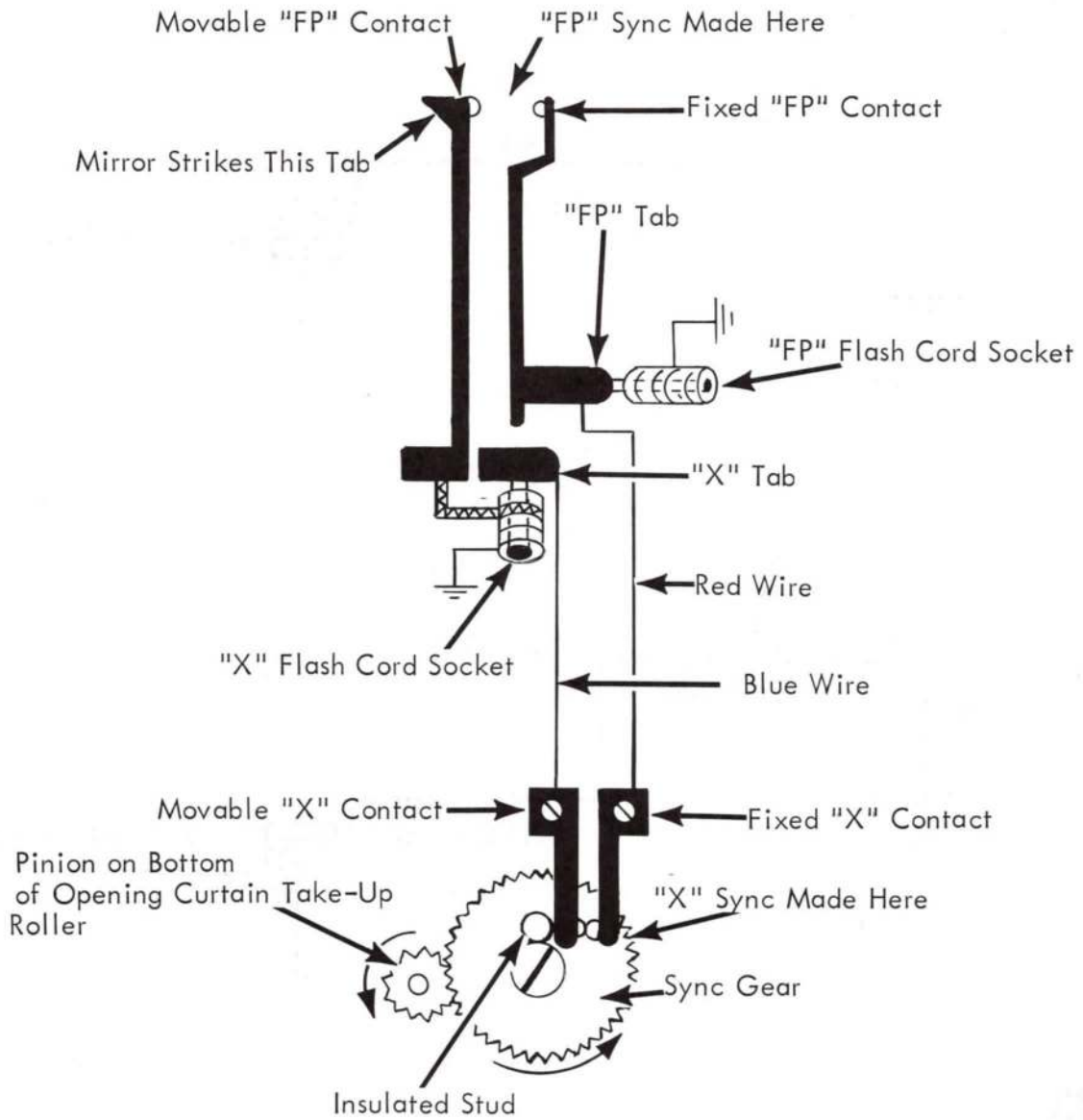

Curved Arrows Indicate Directions Gears Turn on Winding Rotation

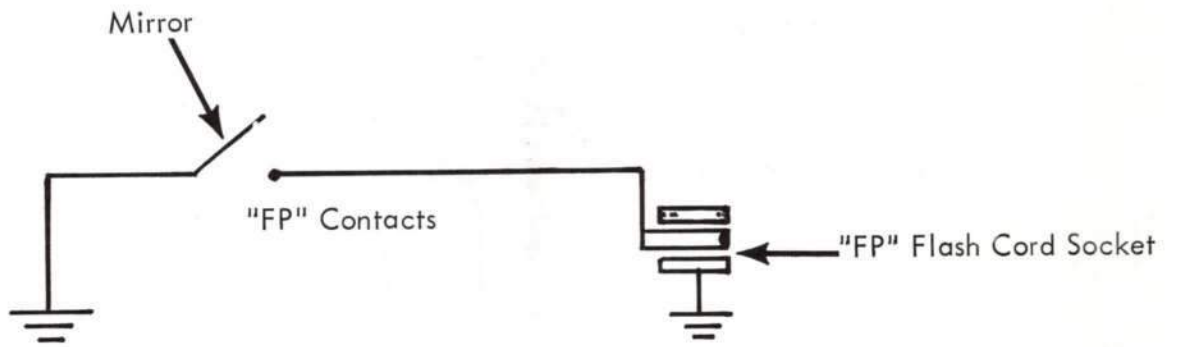

A. "FP" Flash Circuit

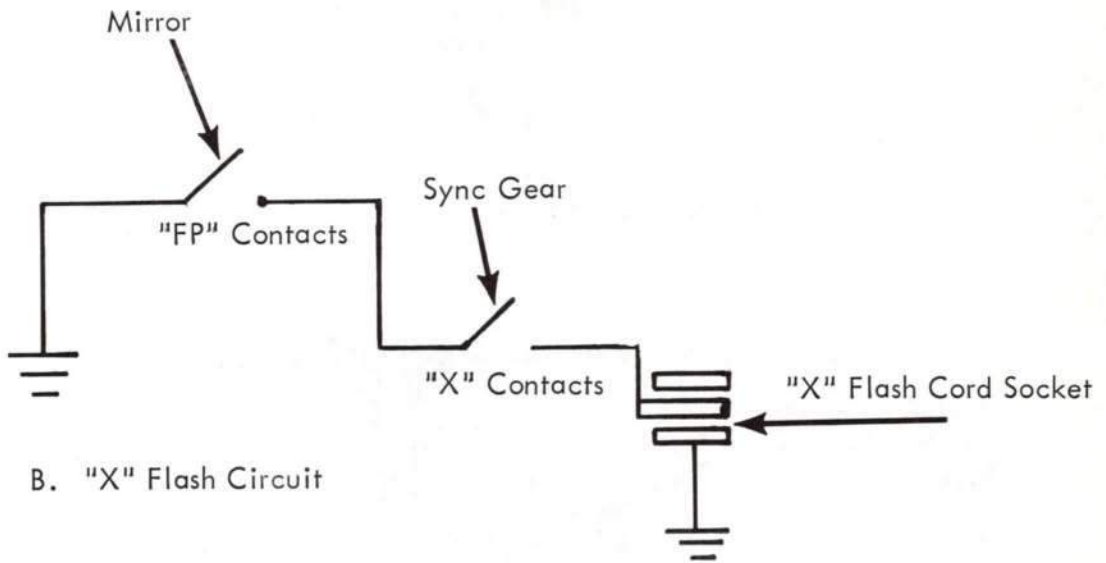

B. "X" Flash Circuit

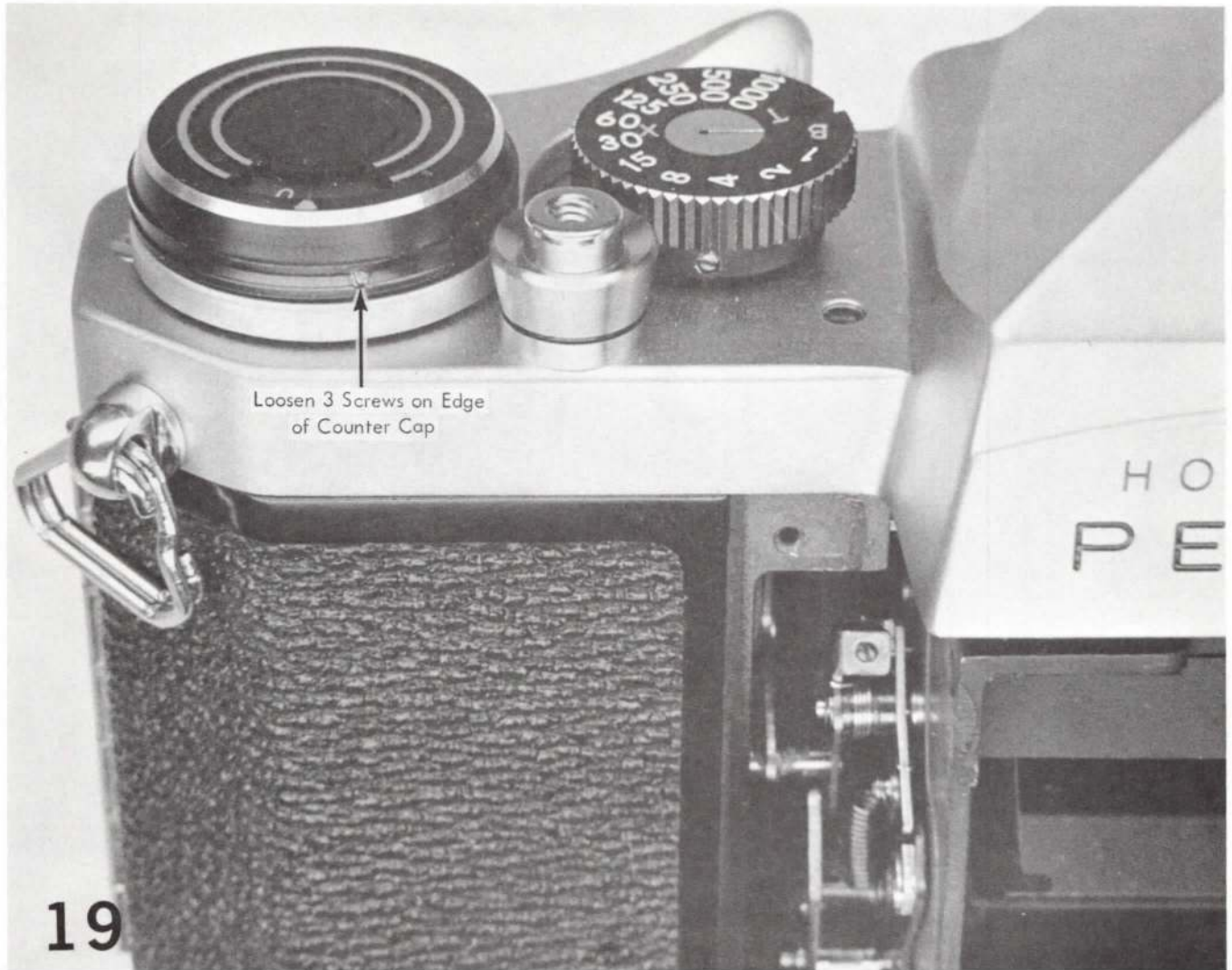

19

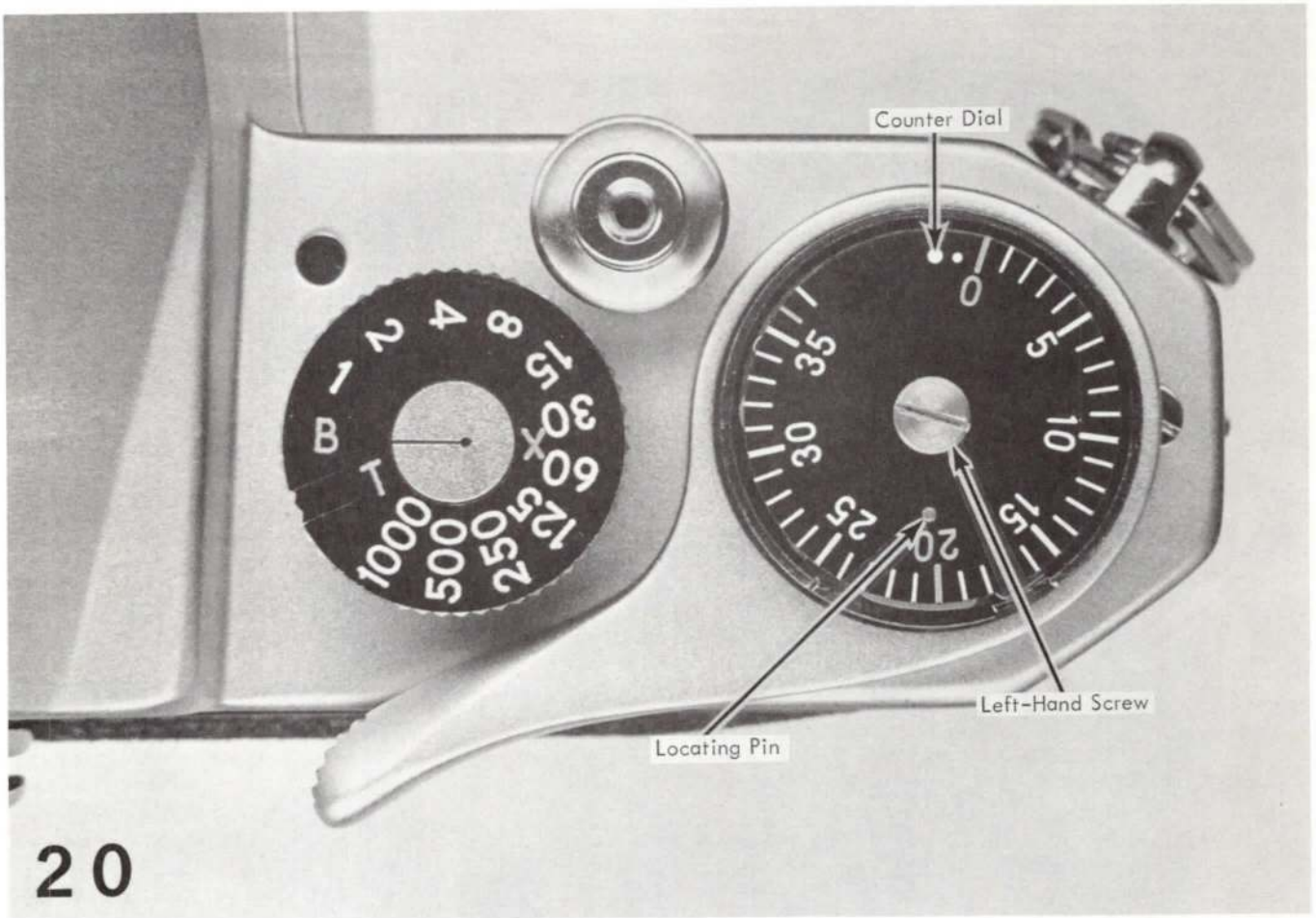

20

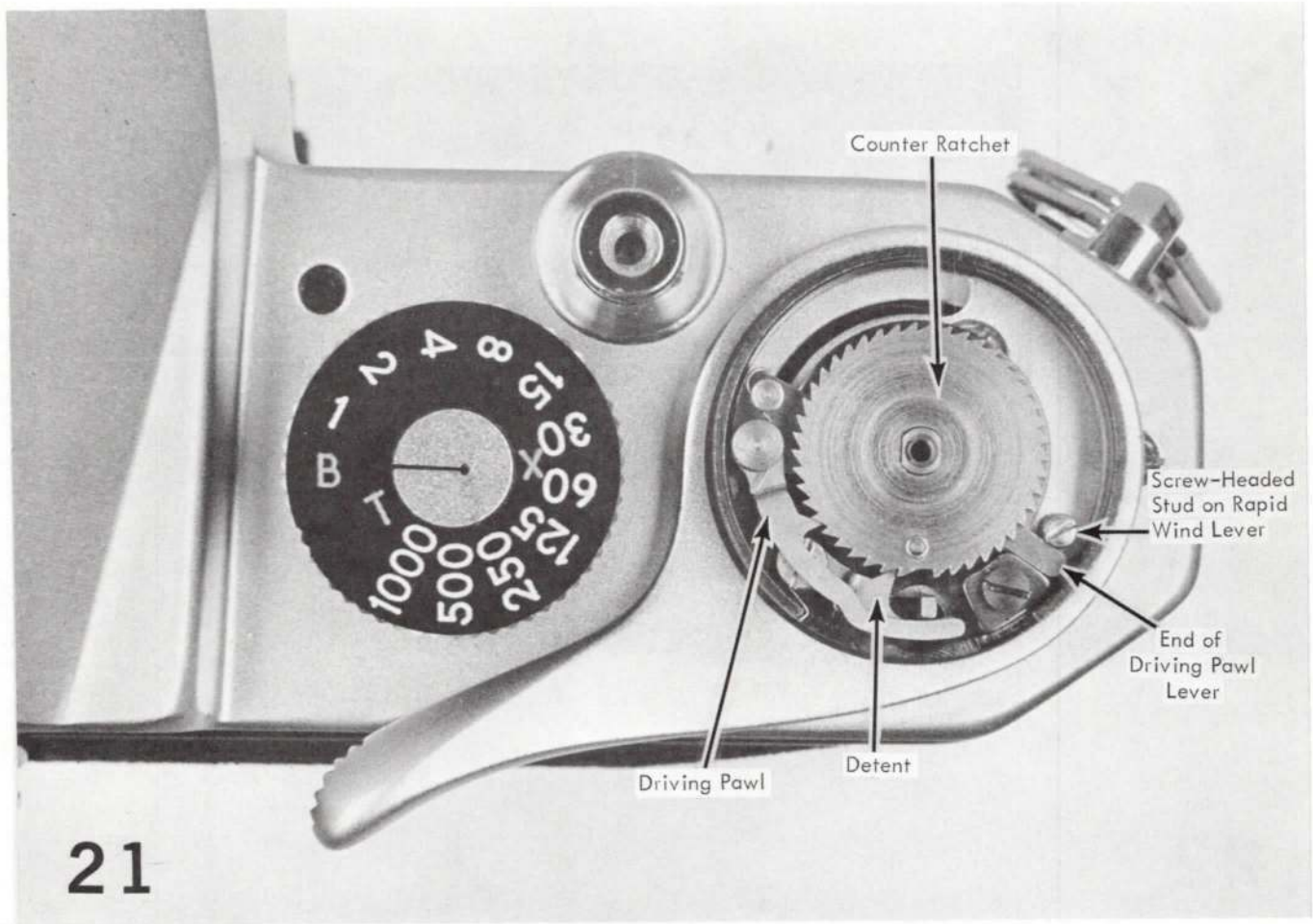

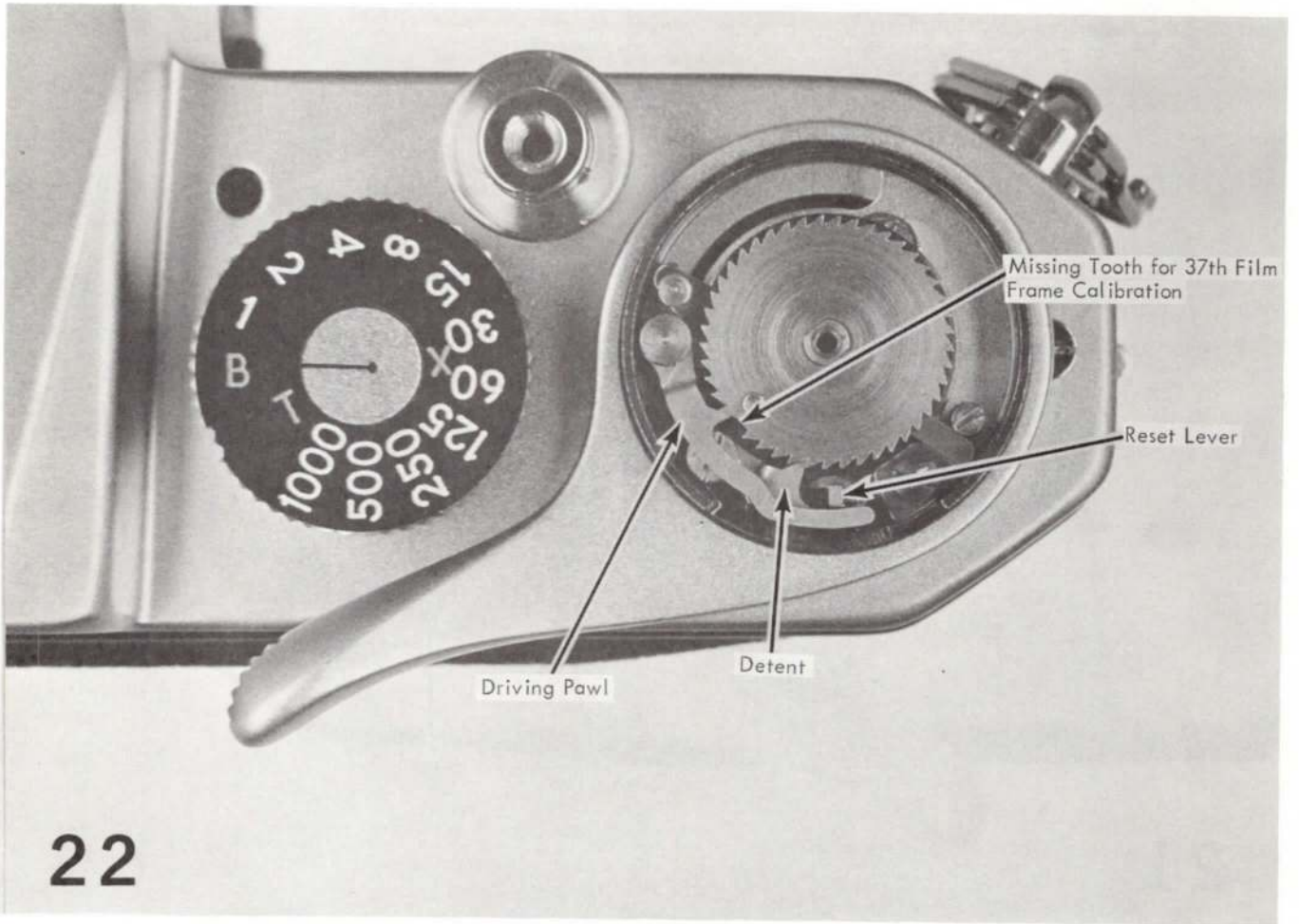

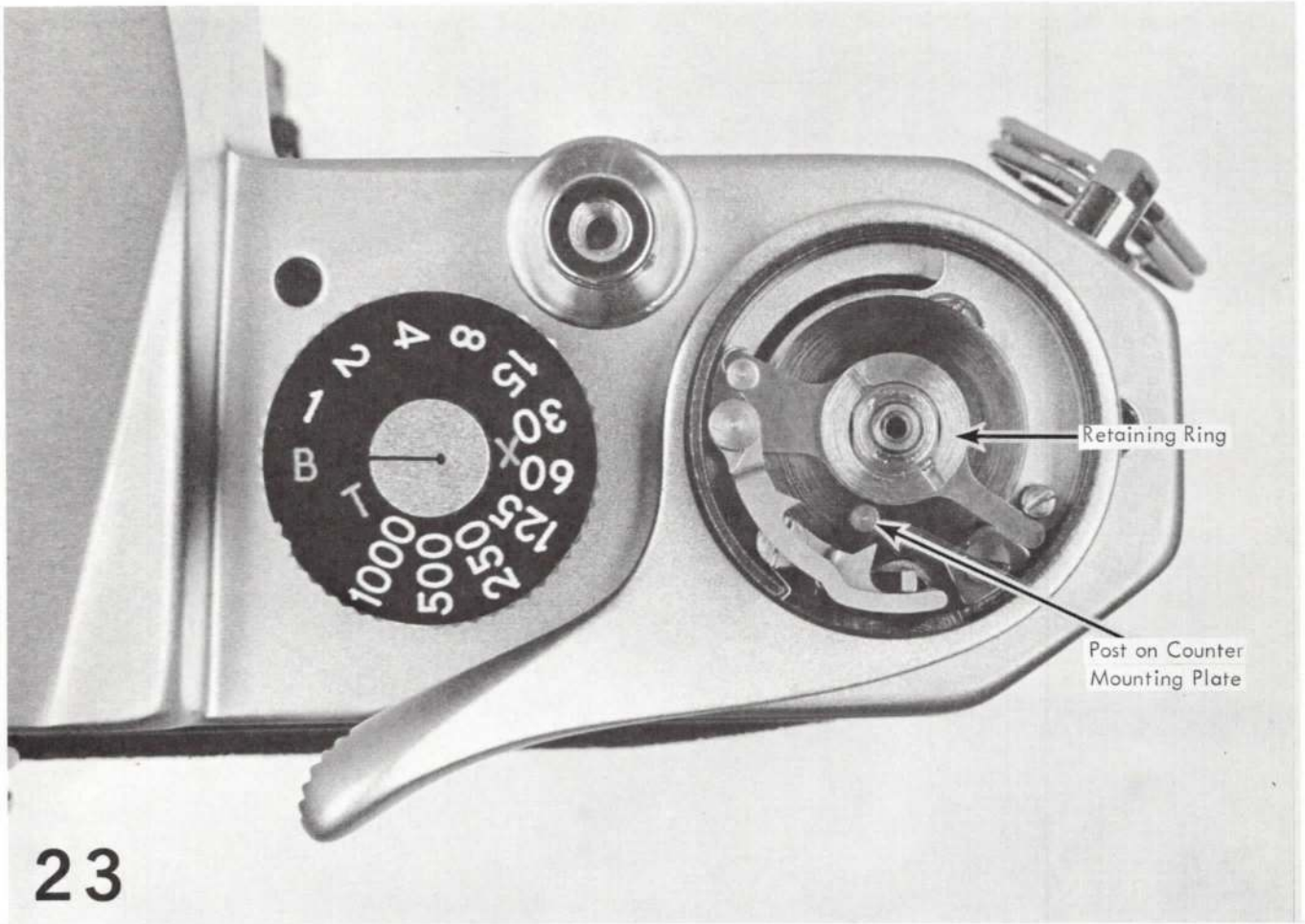

Retaining Ring

Post on Counter  
Mounting Plate

23

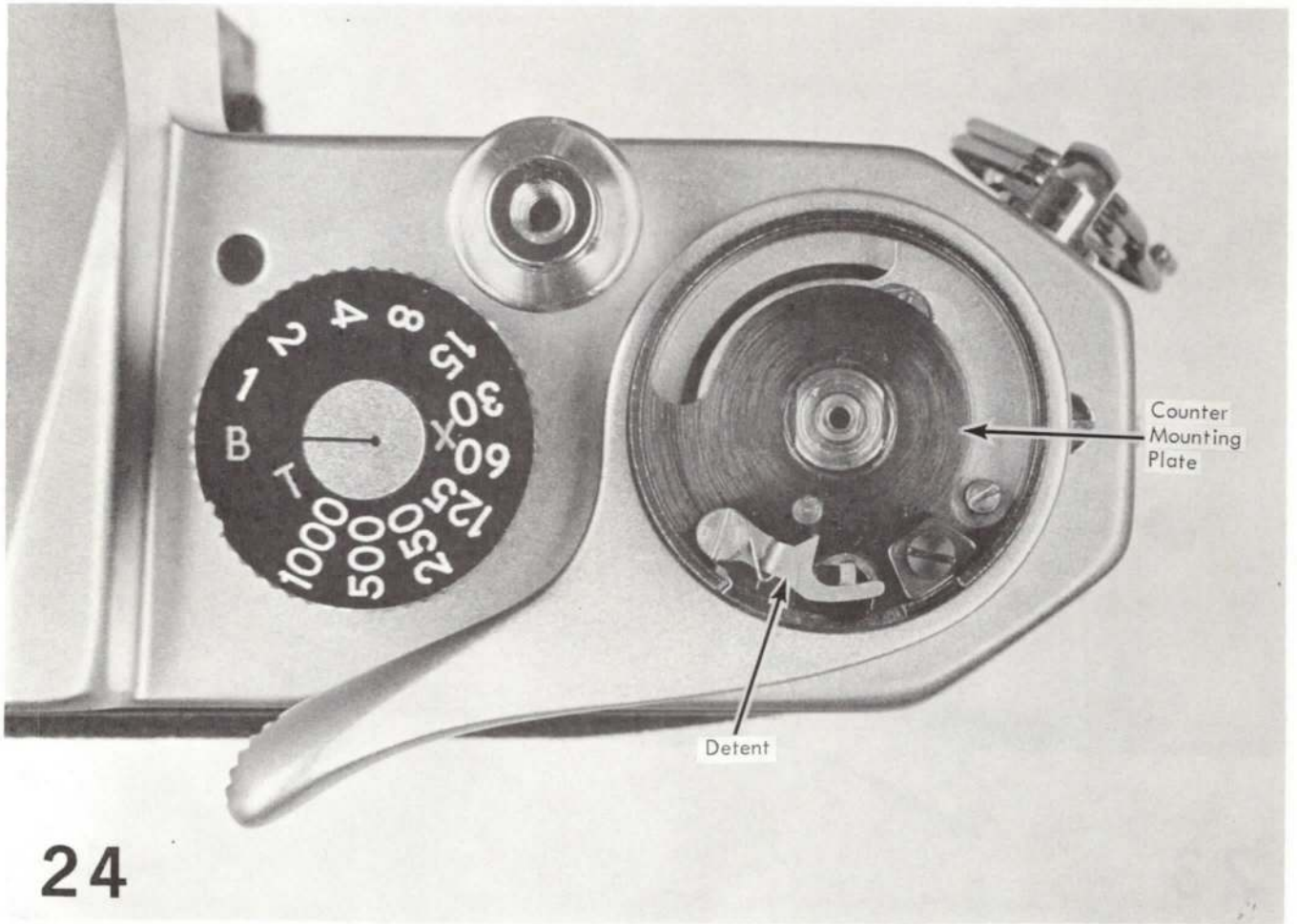

24

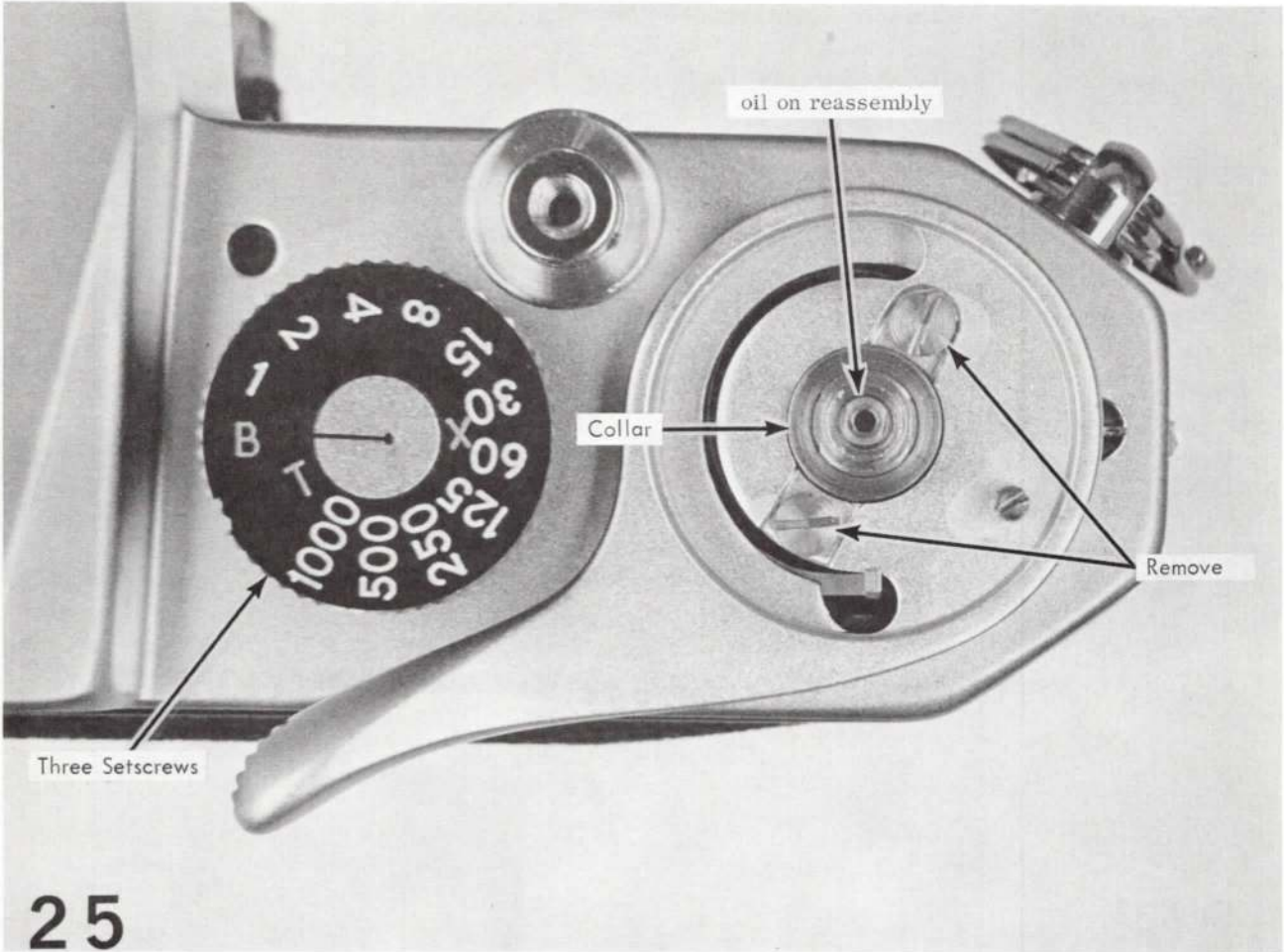

Three Setscrews

oil on reassembly

Collar

Remove

25

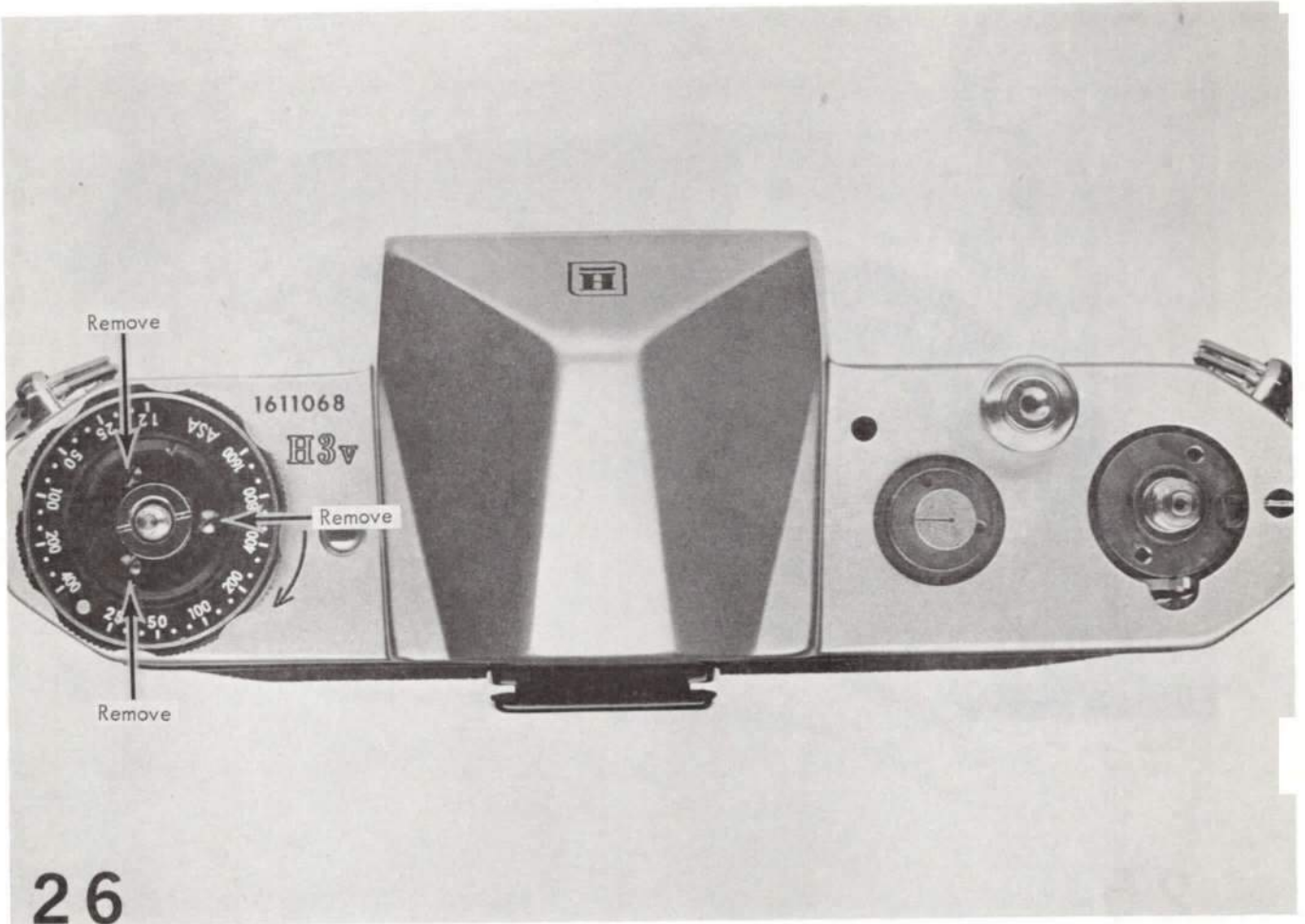

26

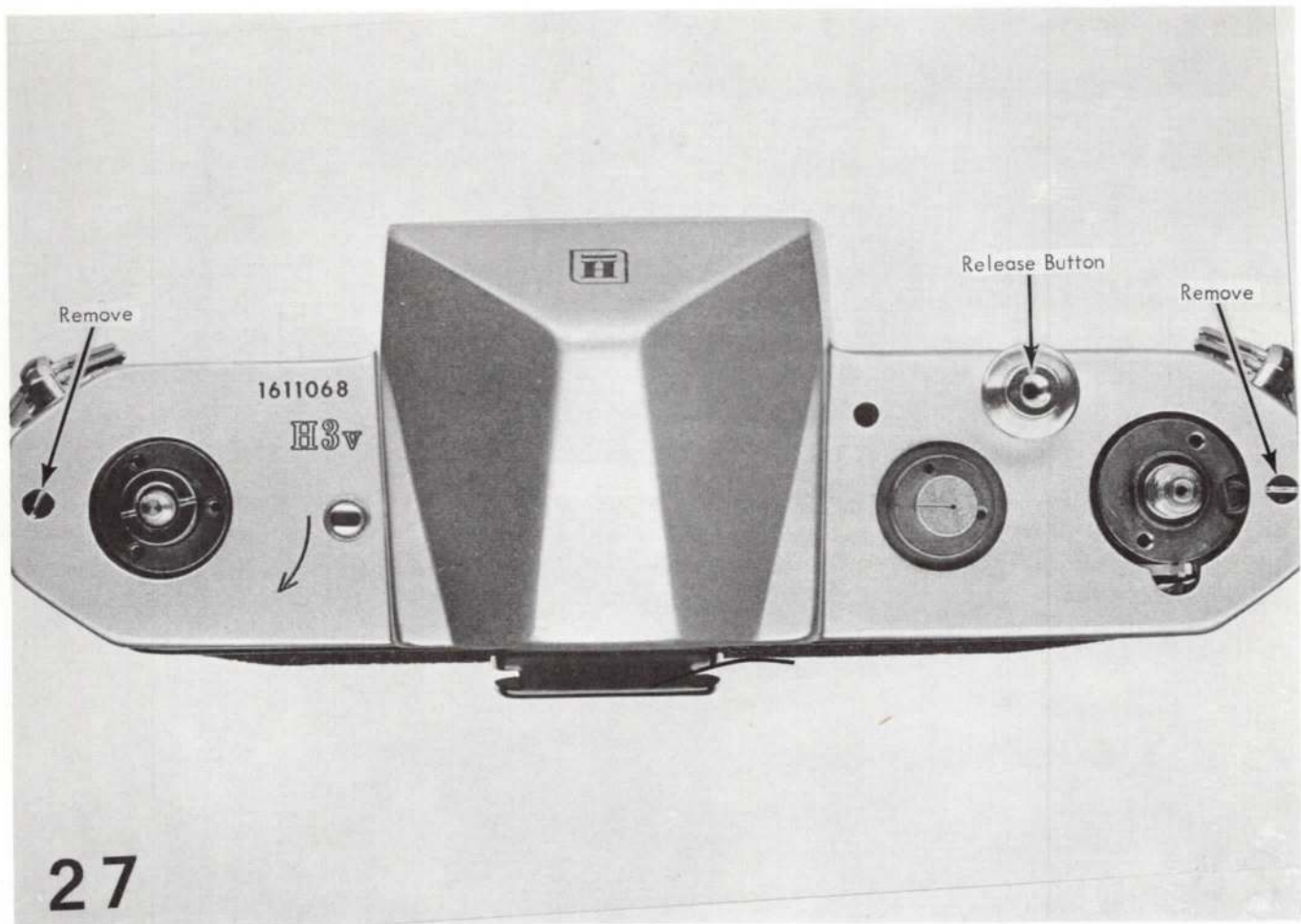

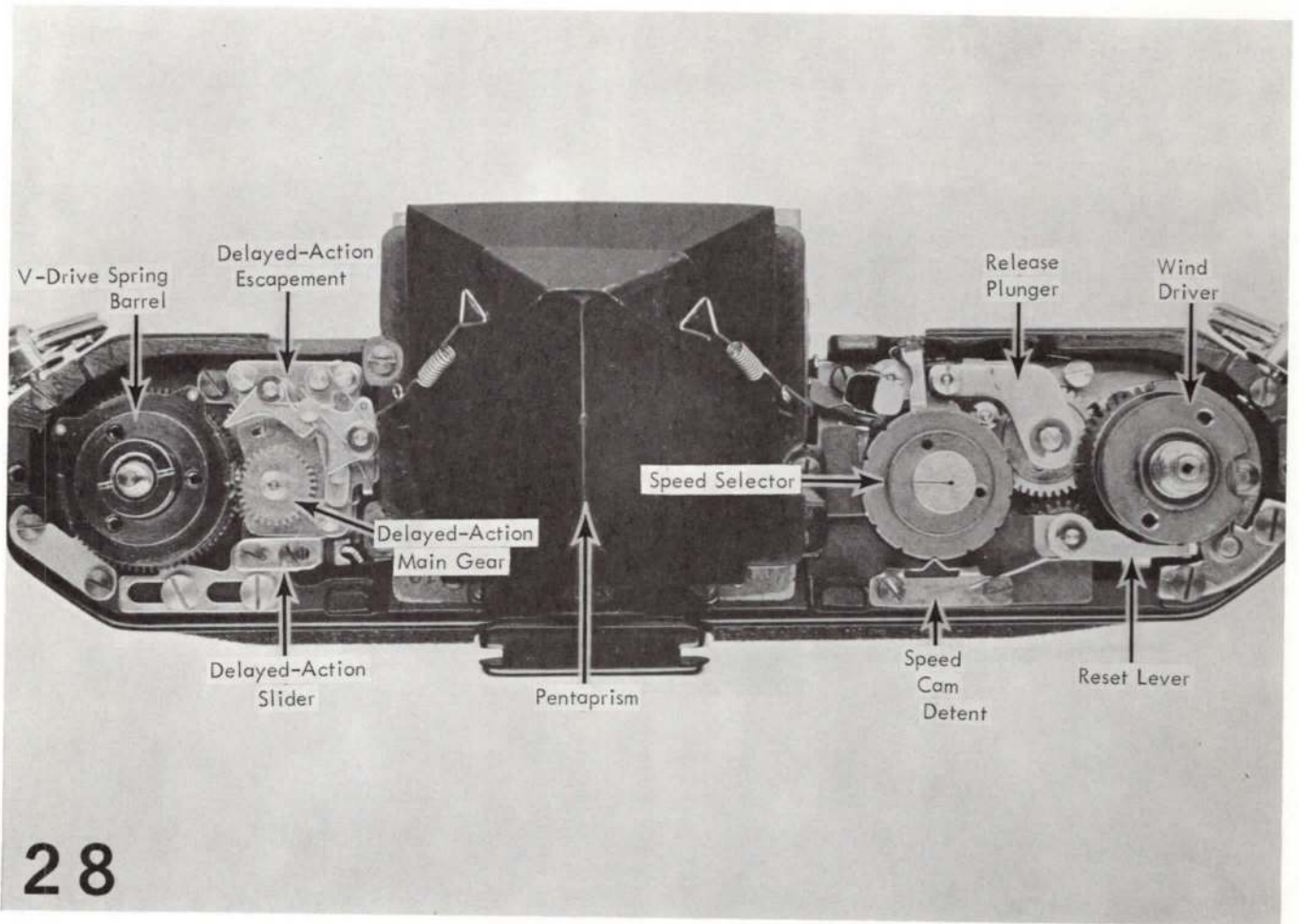

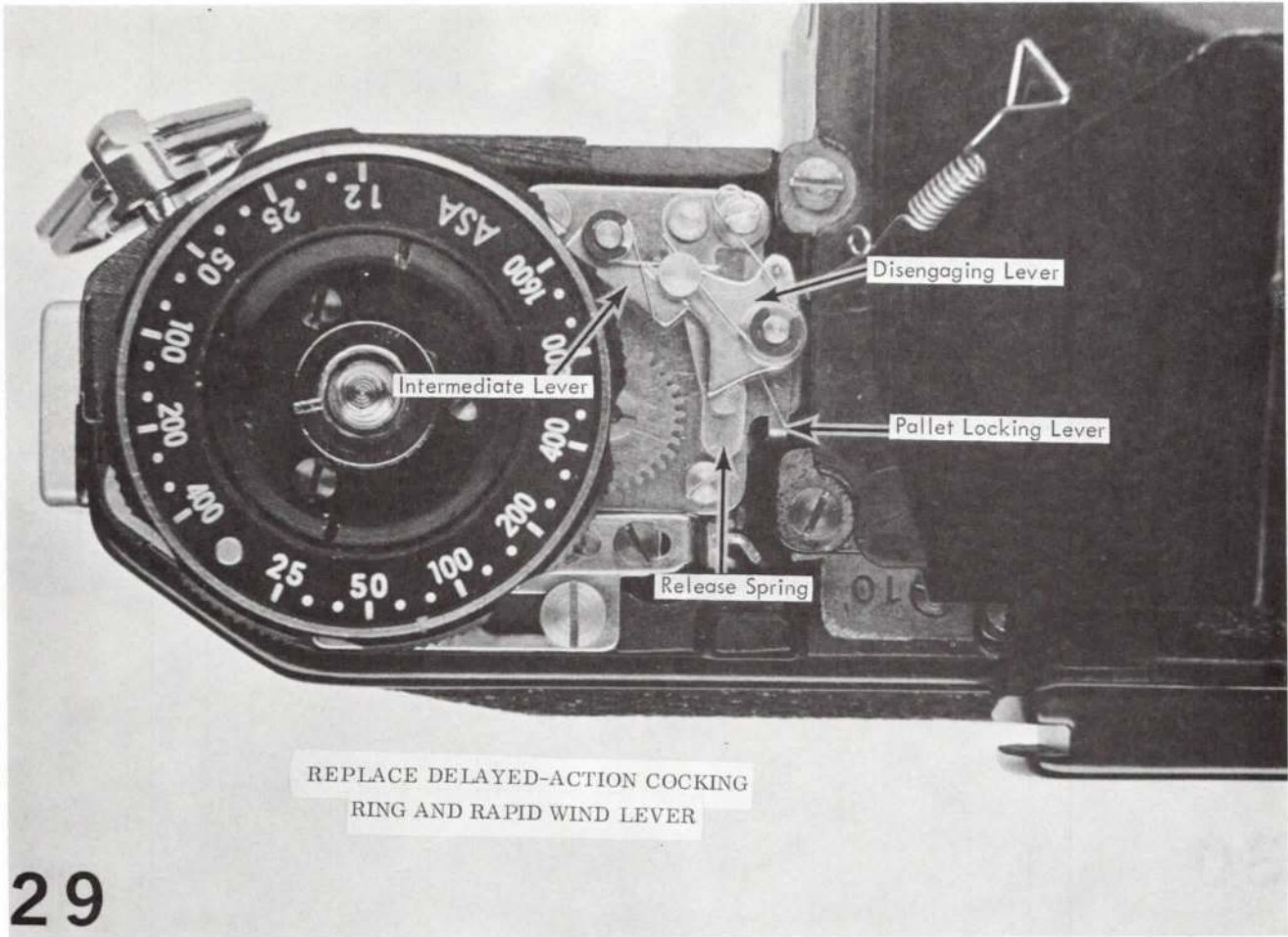

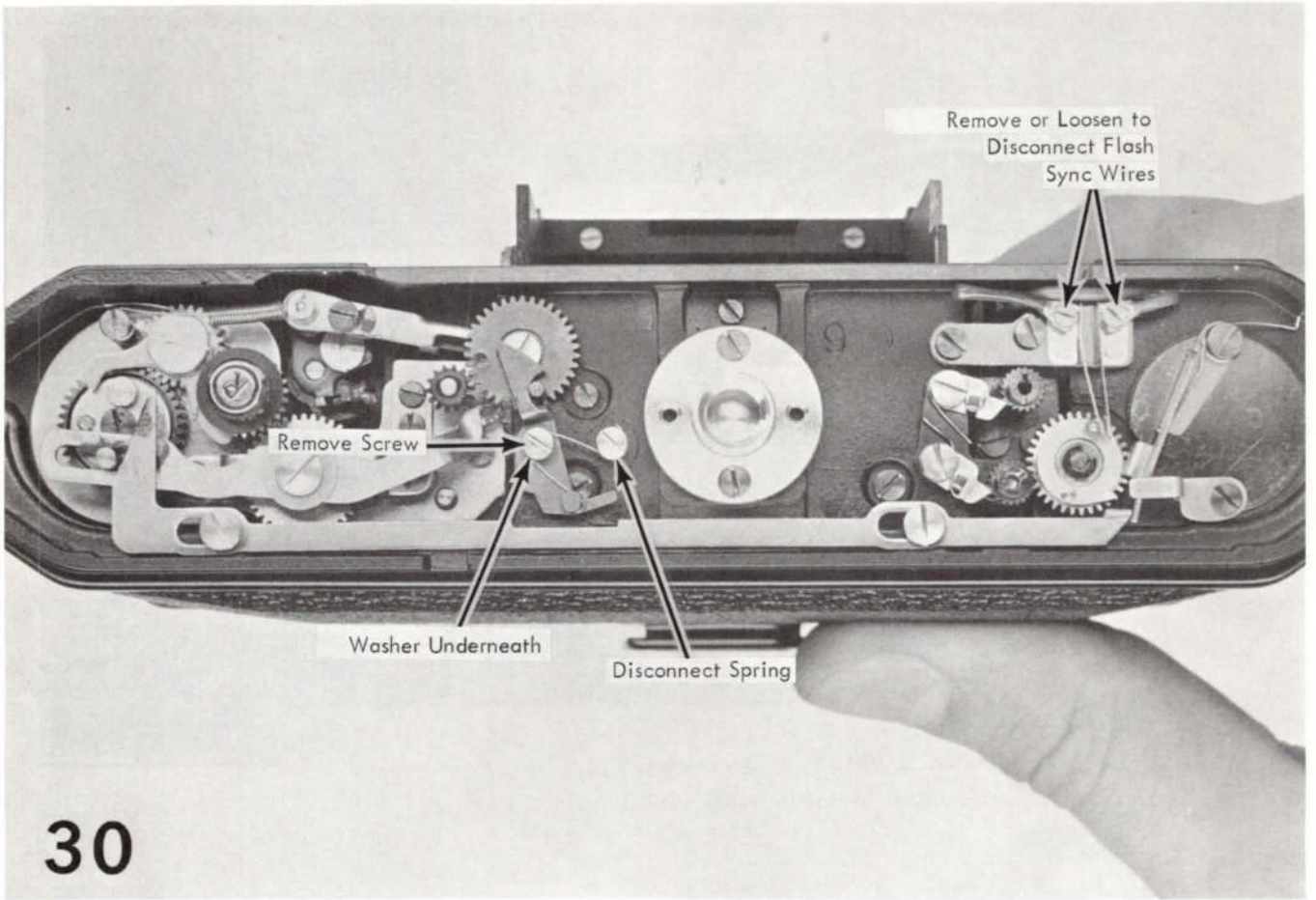

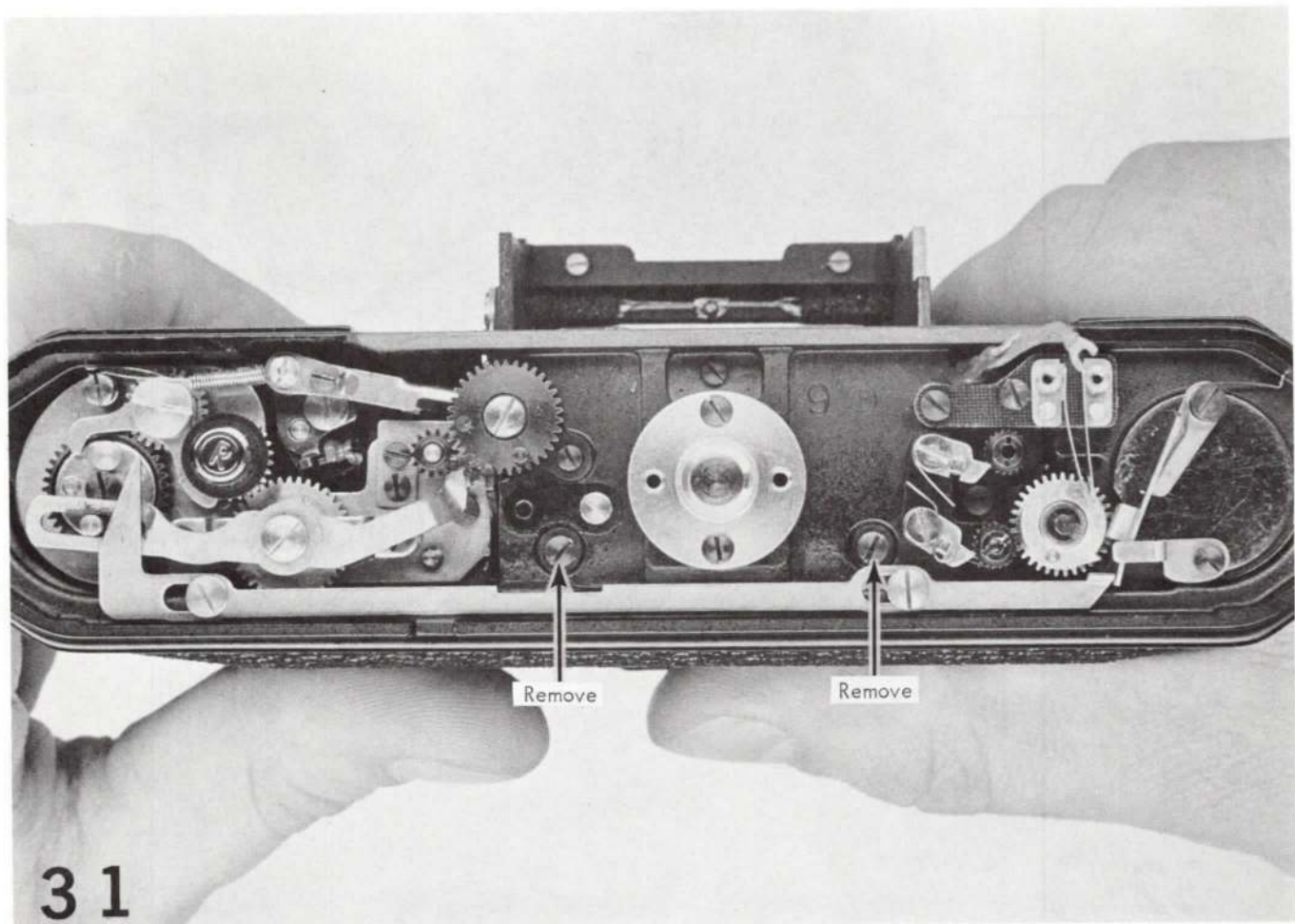

31

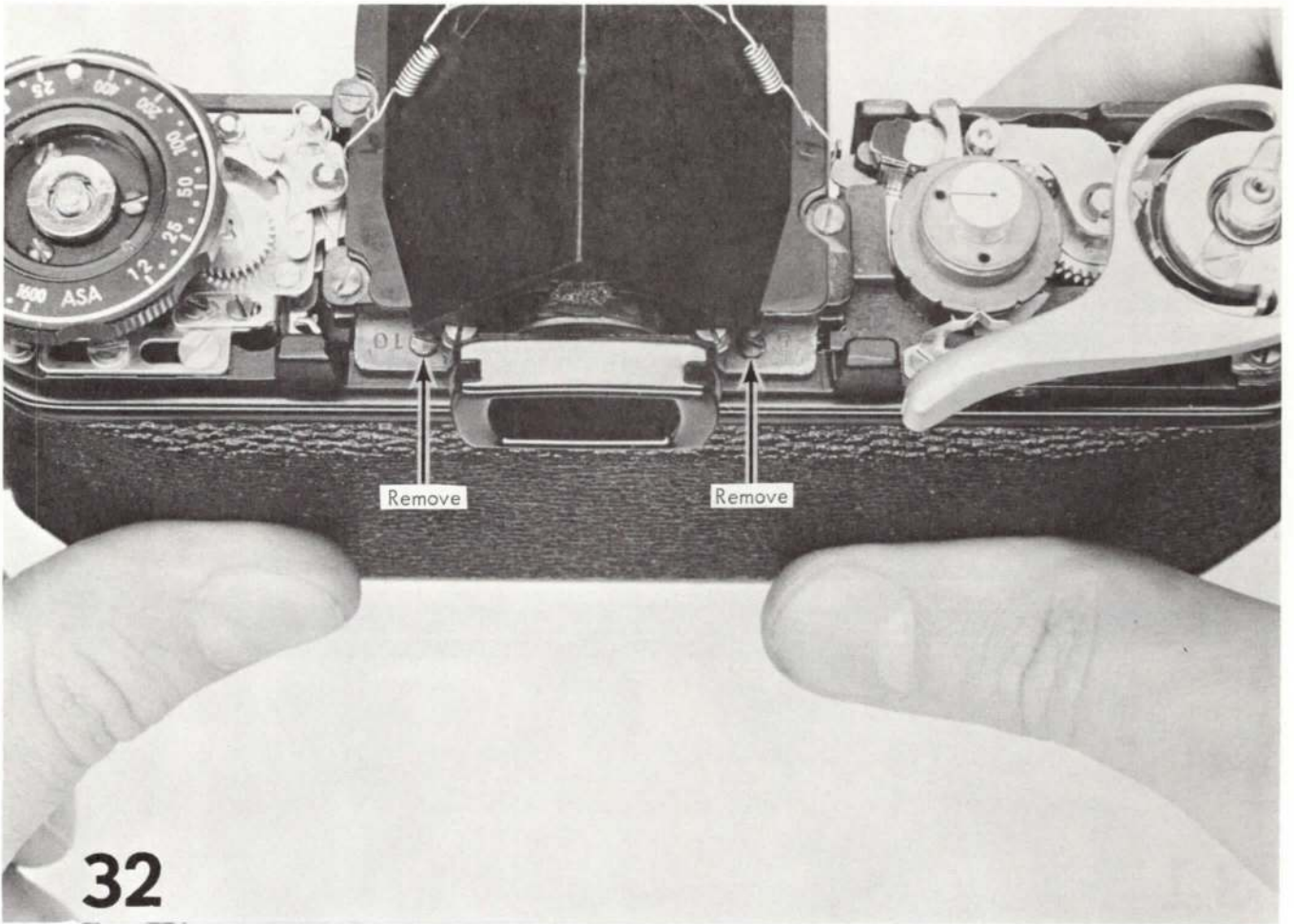

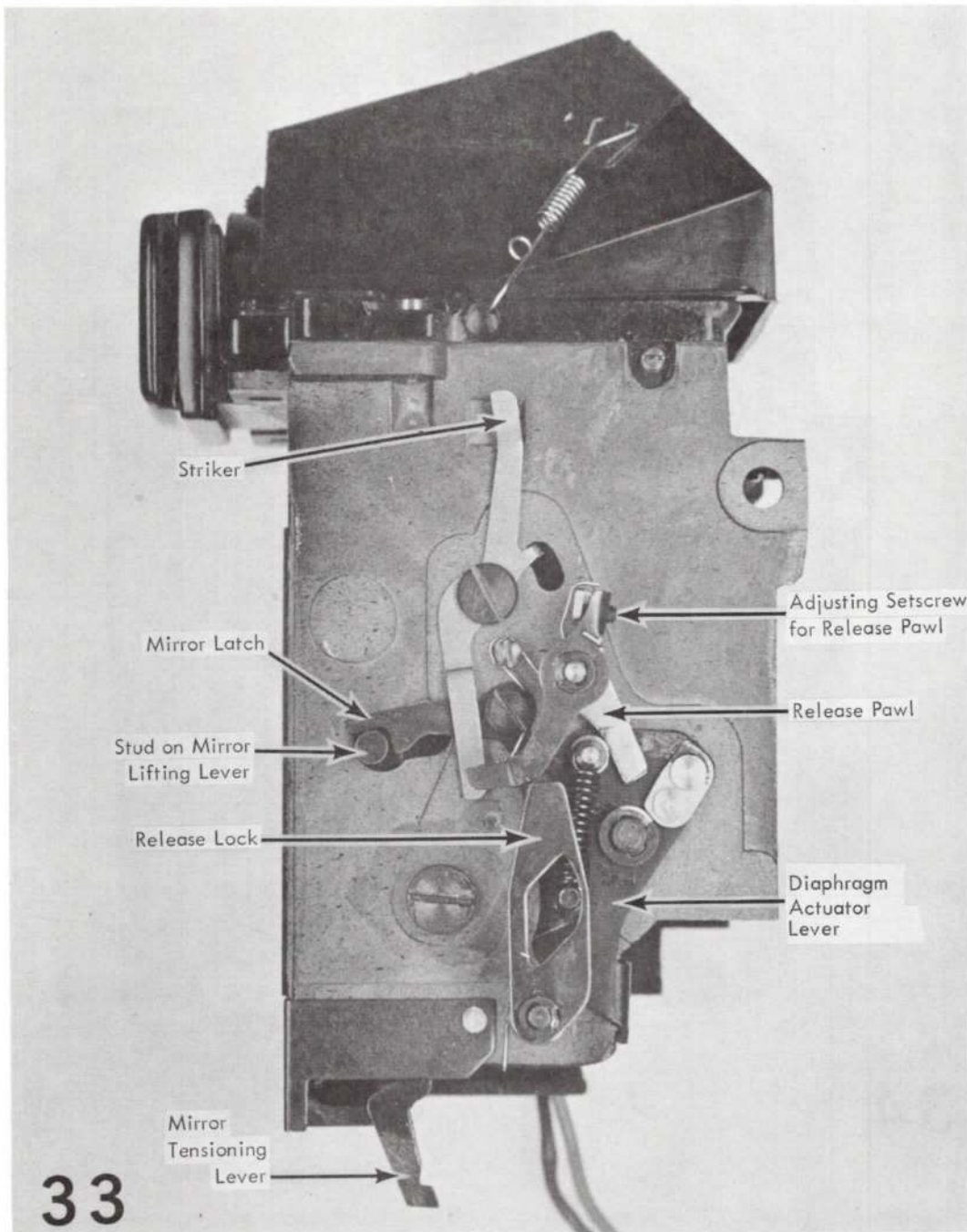

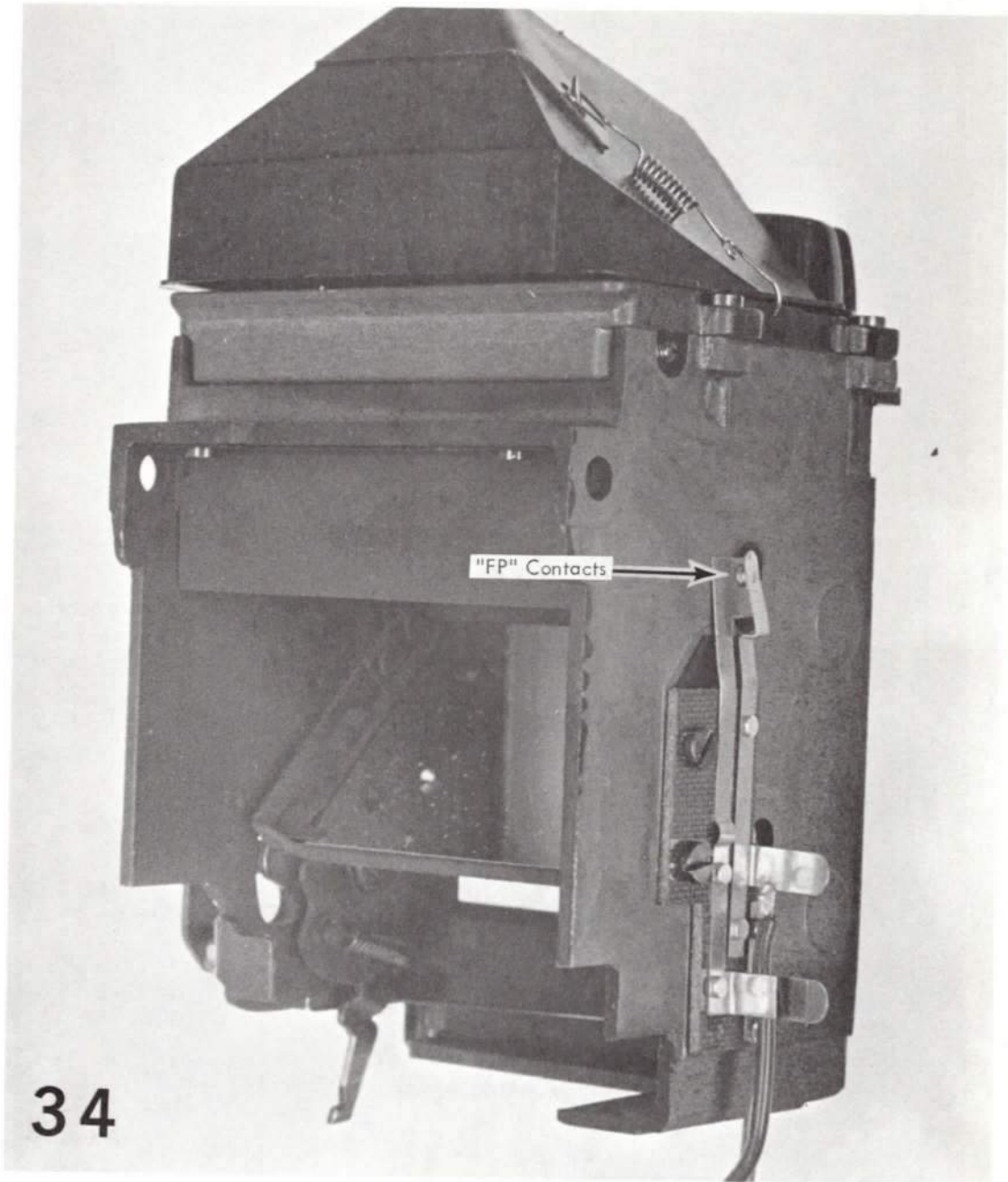

"FP" Contacts

34

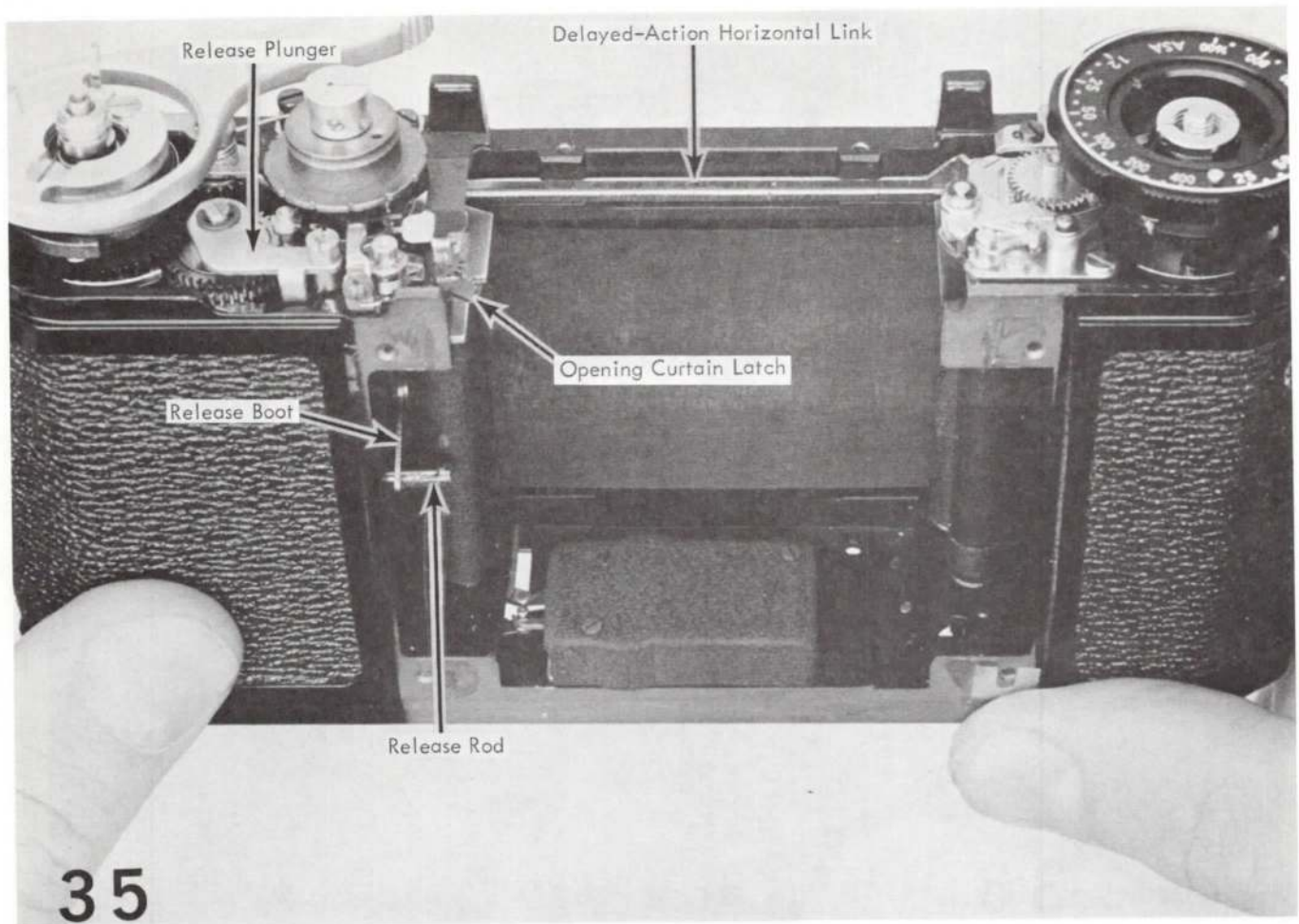

35

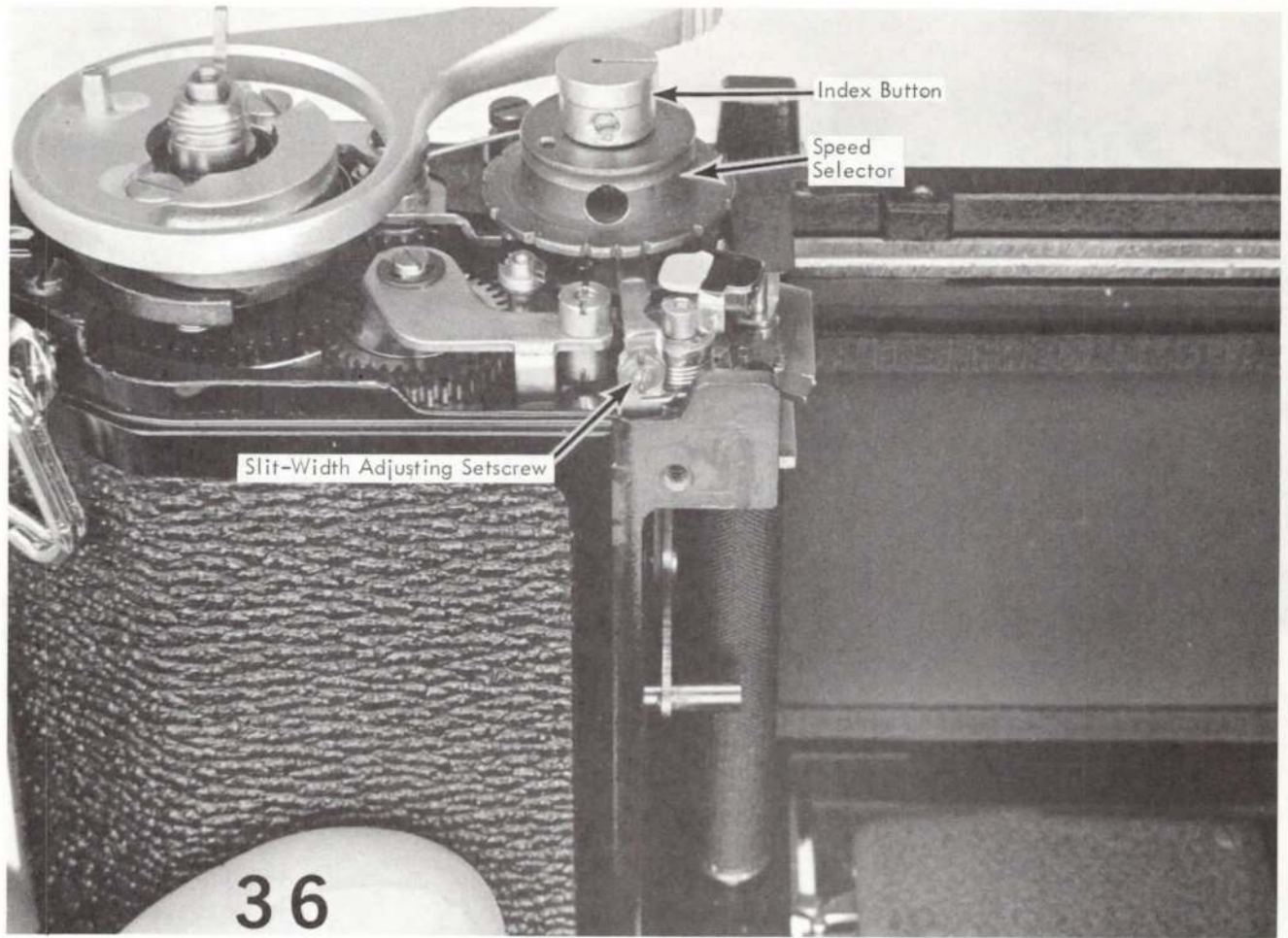

Index Button

Speed Selector

Slit-Width Adjusting Setscrew

36

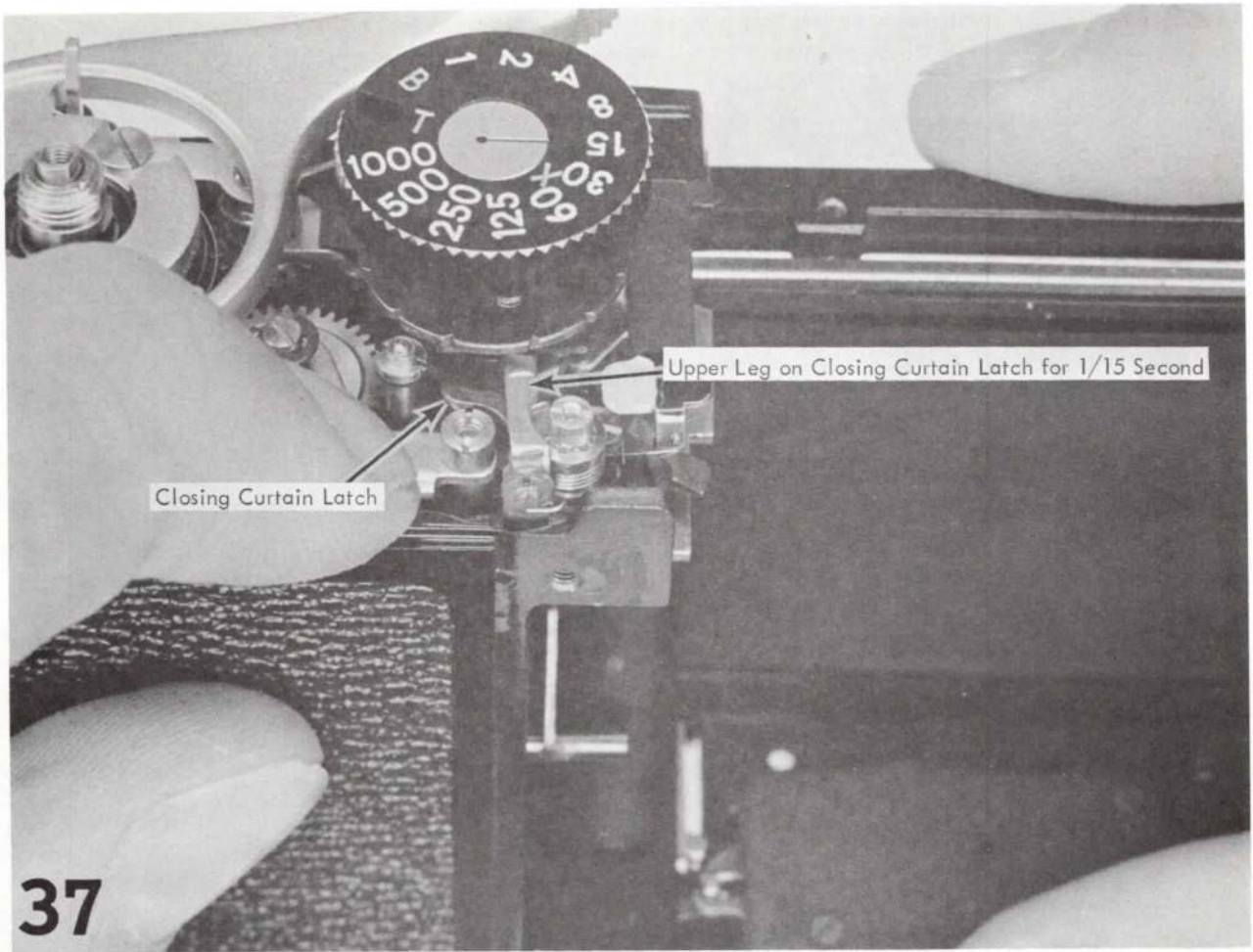

Closing Curtain Latch

Upper Leg on Closing Curtain Latch for 1/15 Second

37

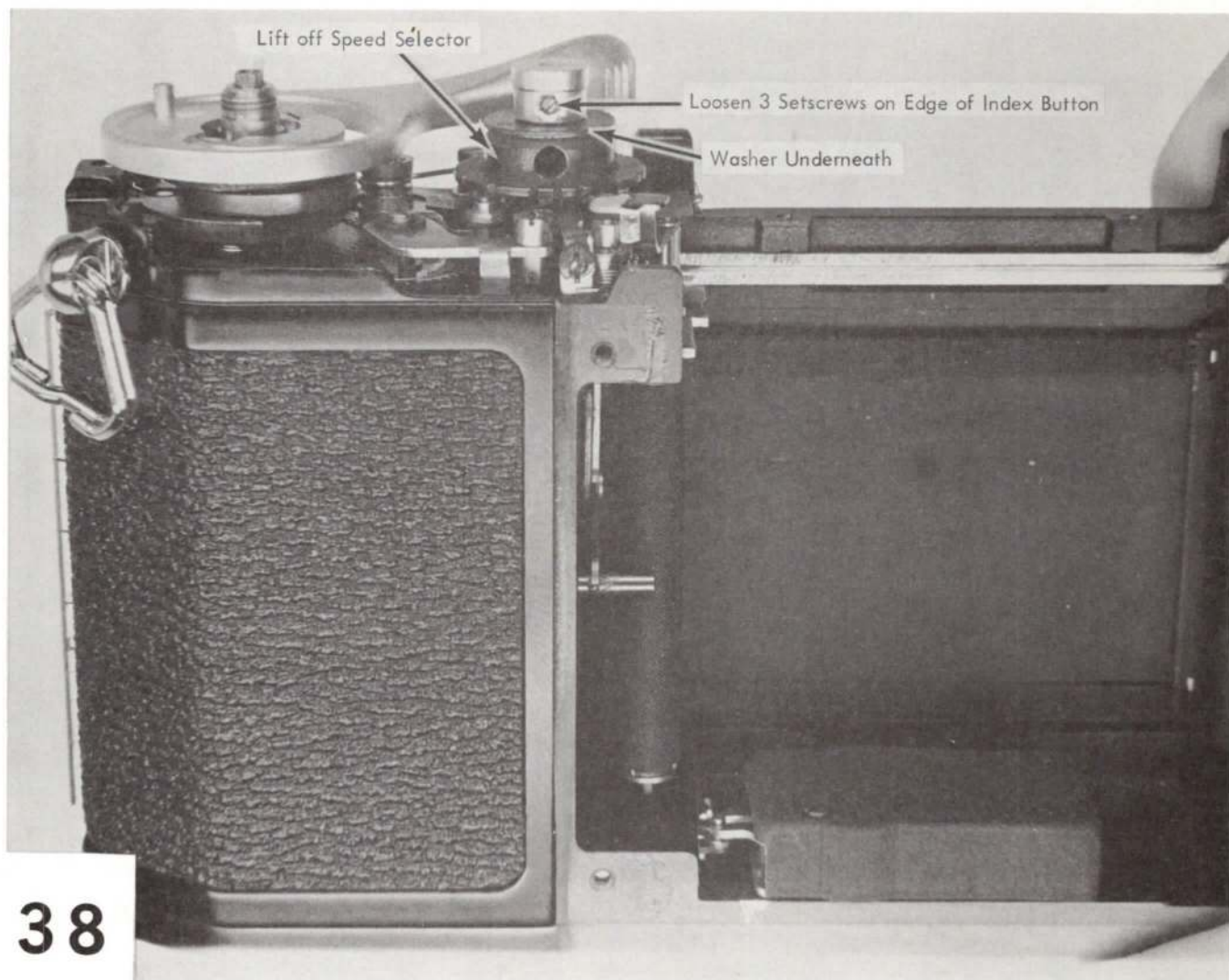

38

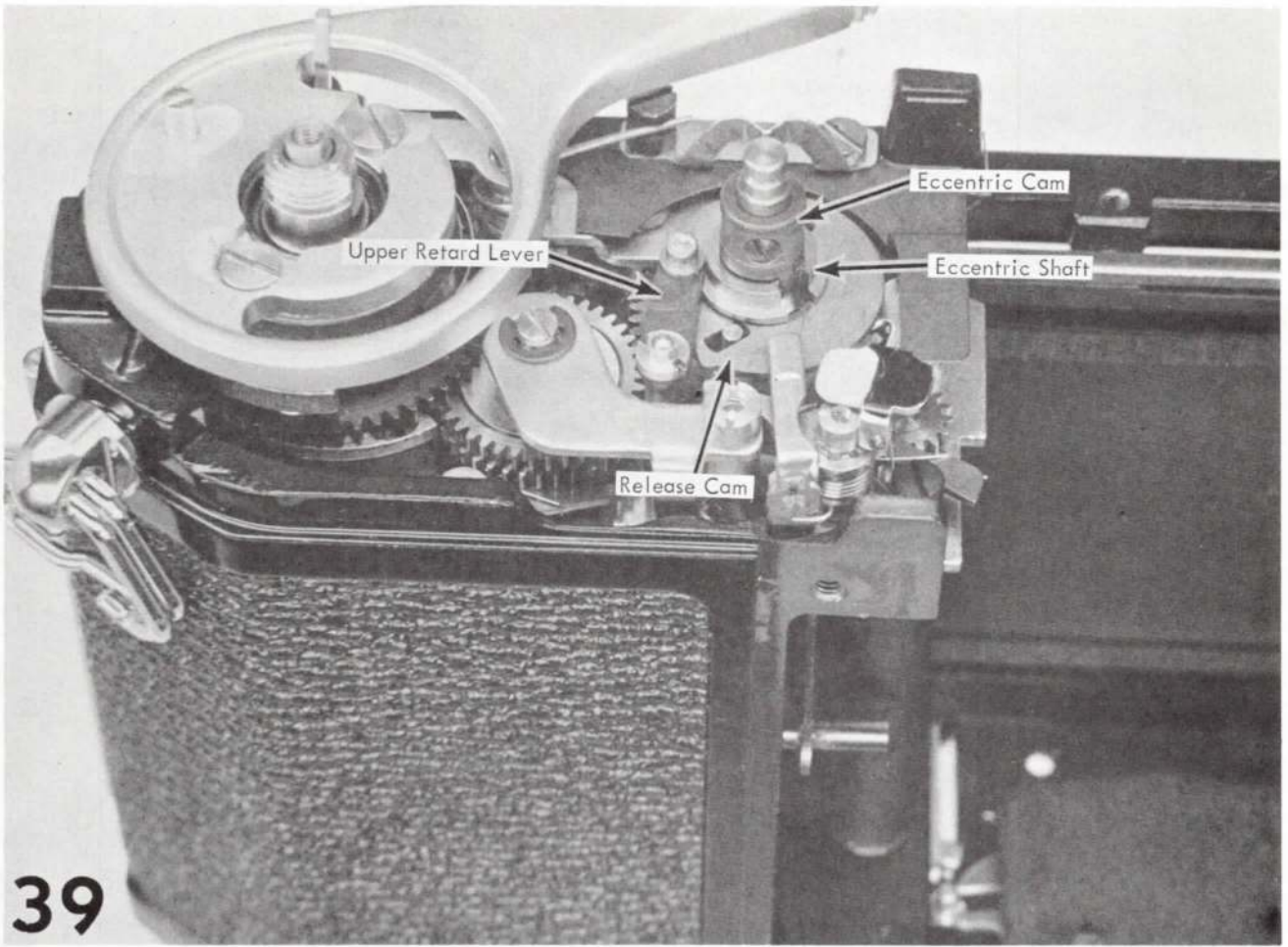

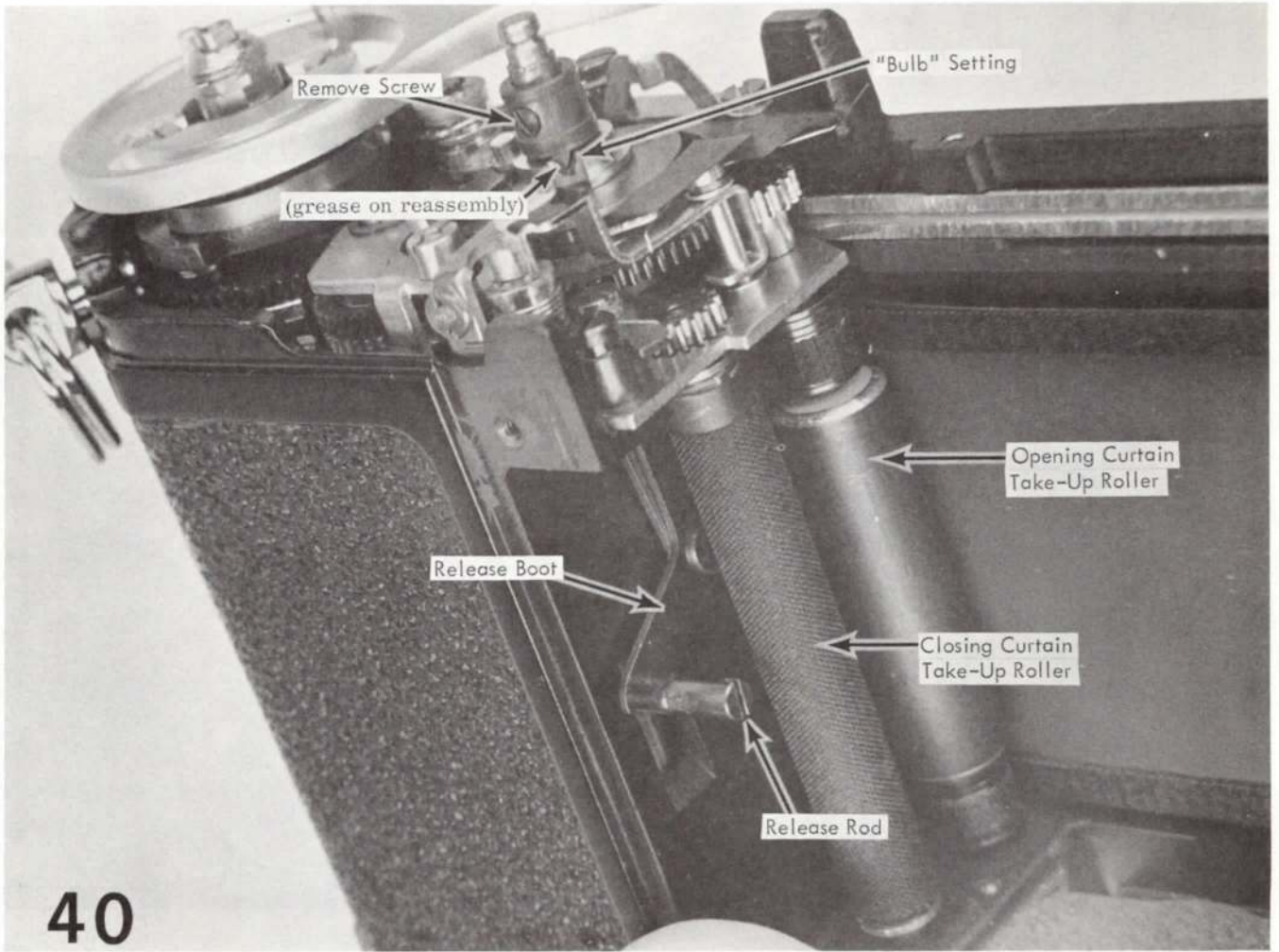

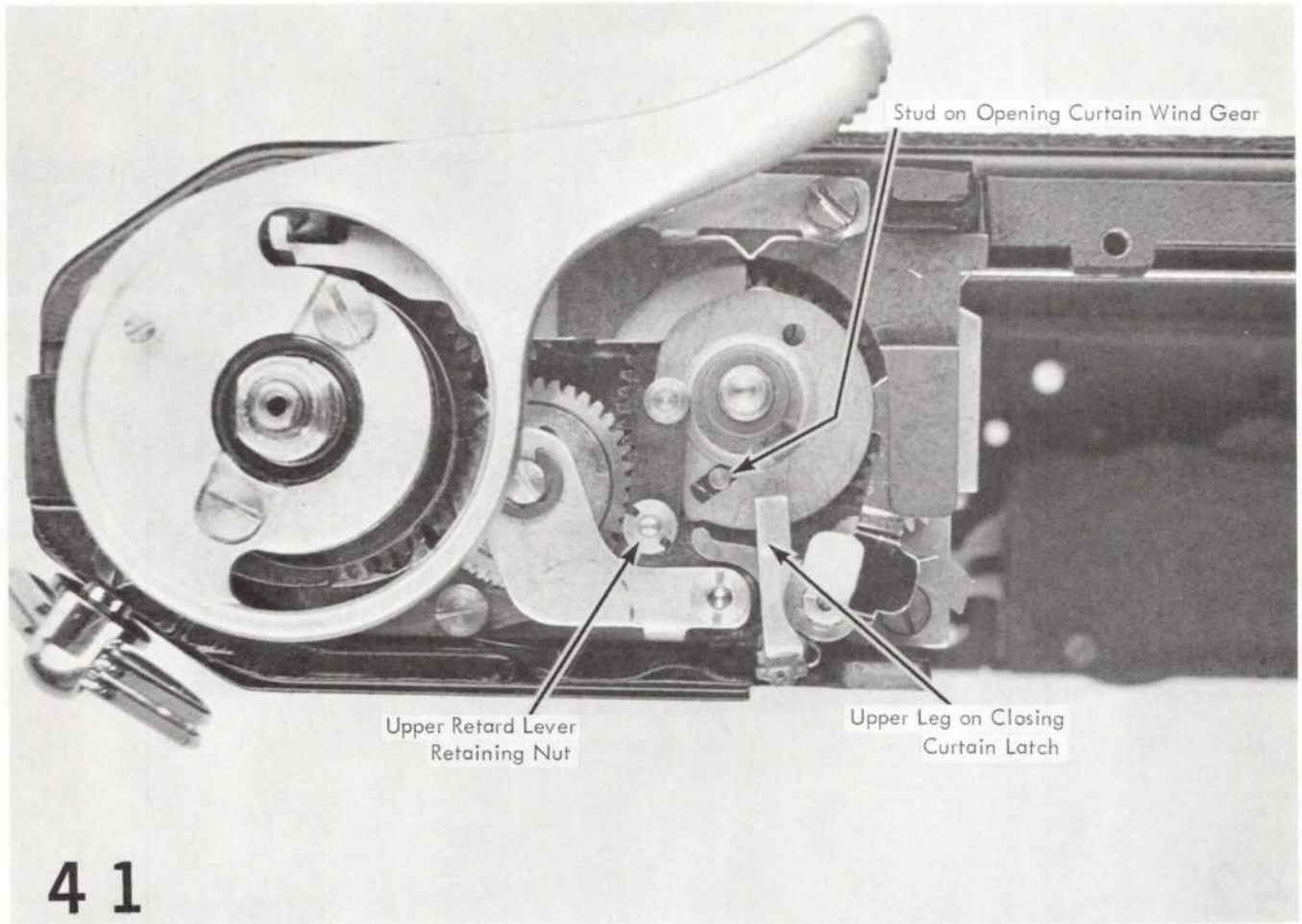

41

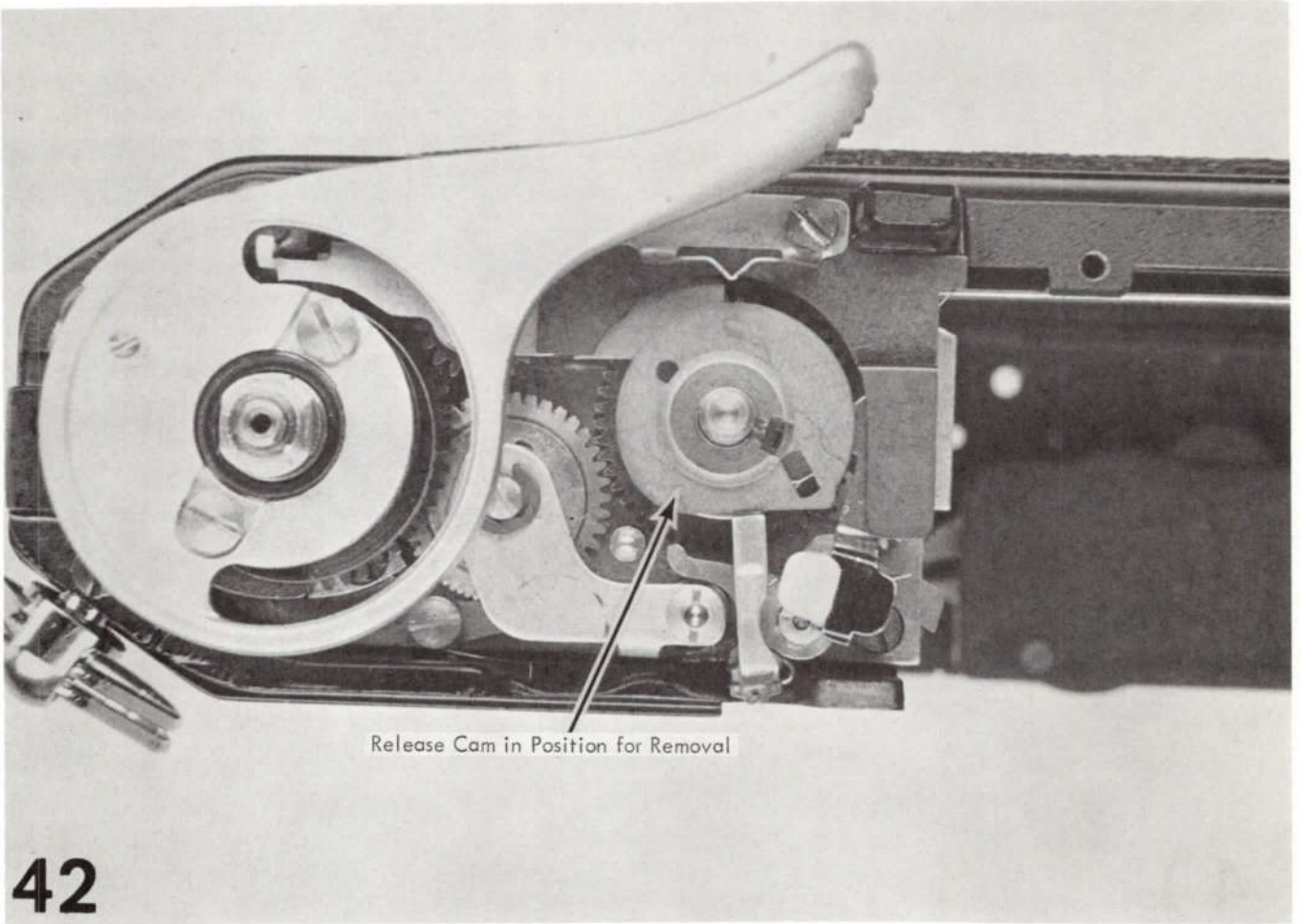

Release Cam in Position for Removal

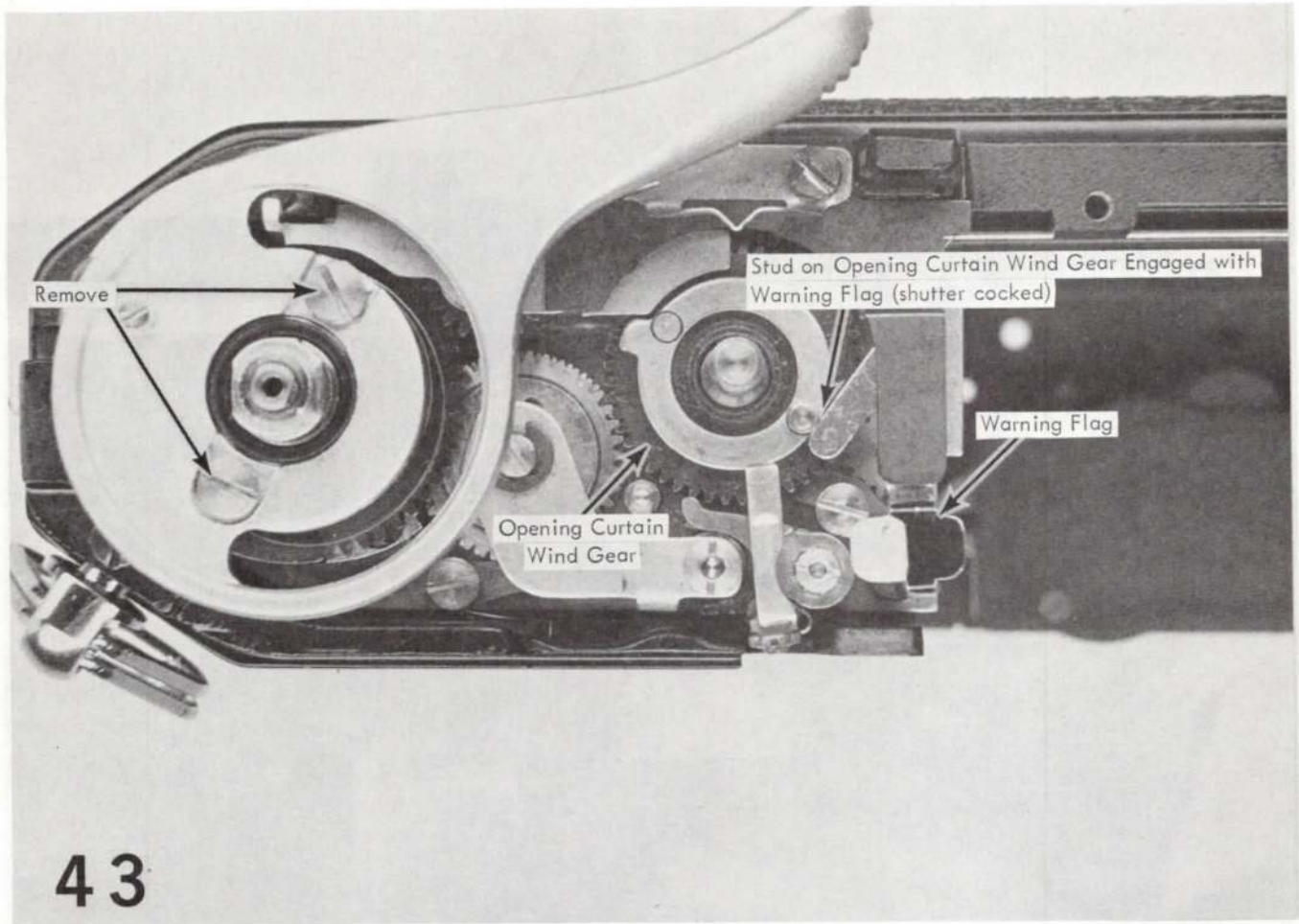

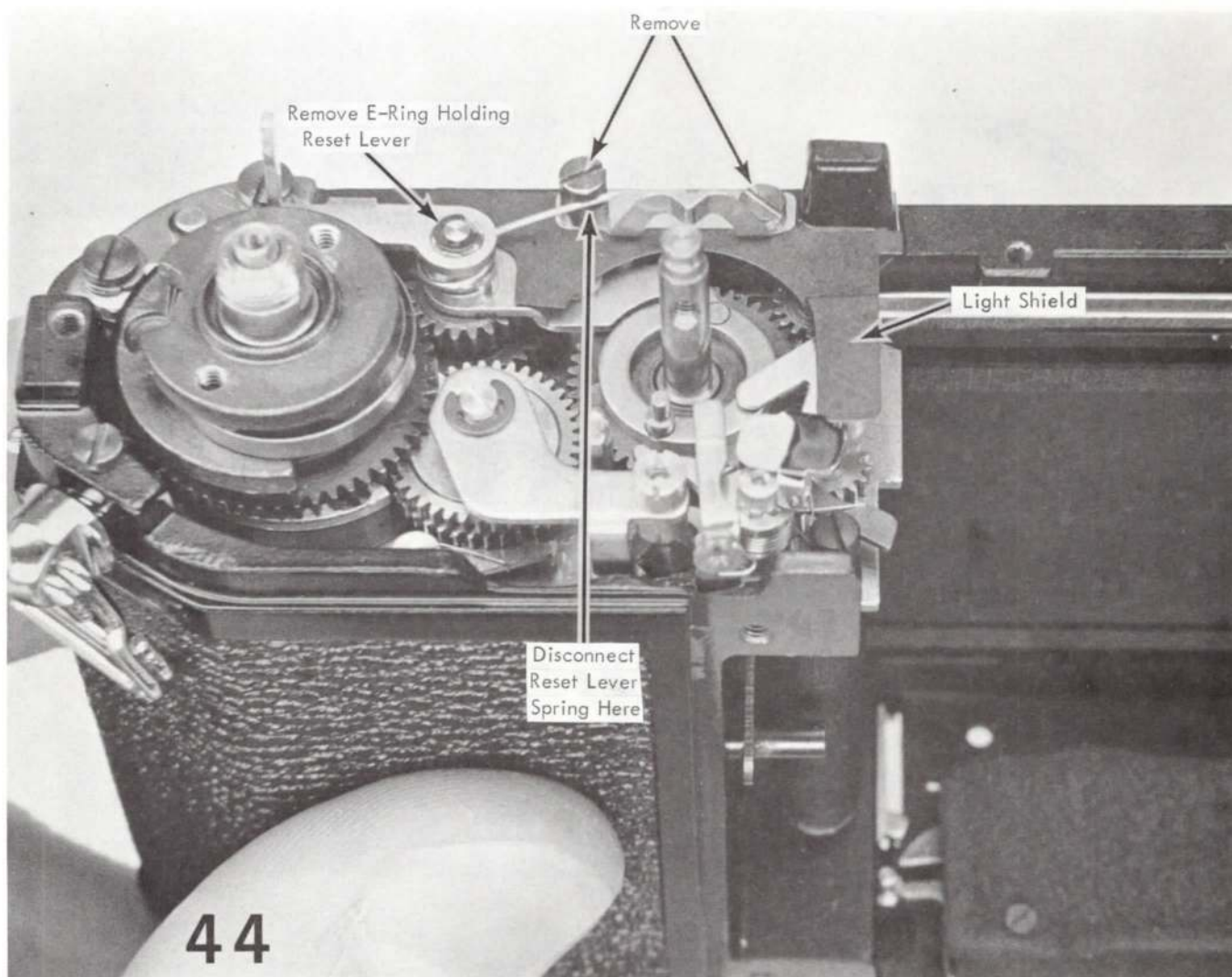

44

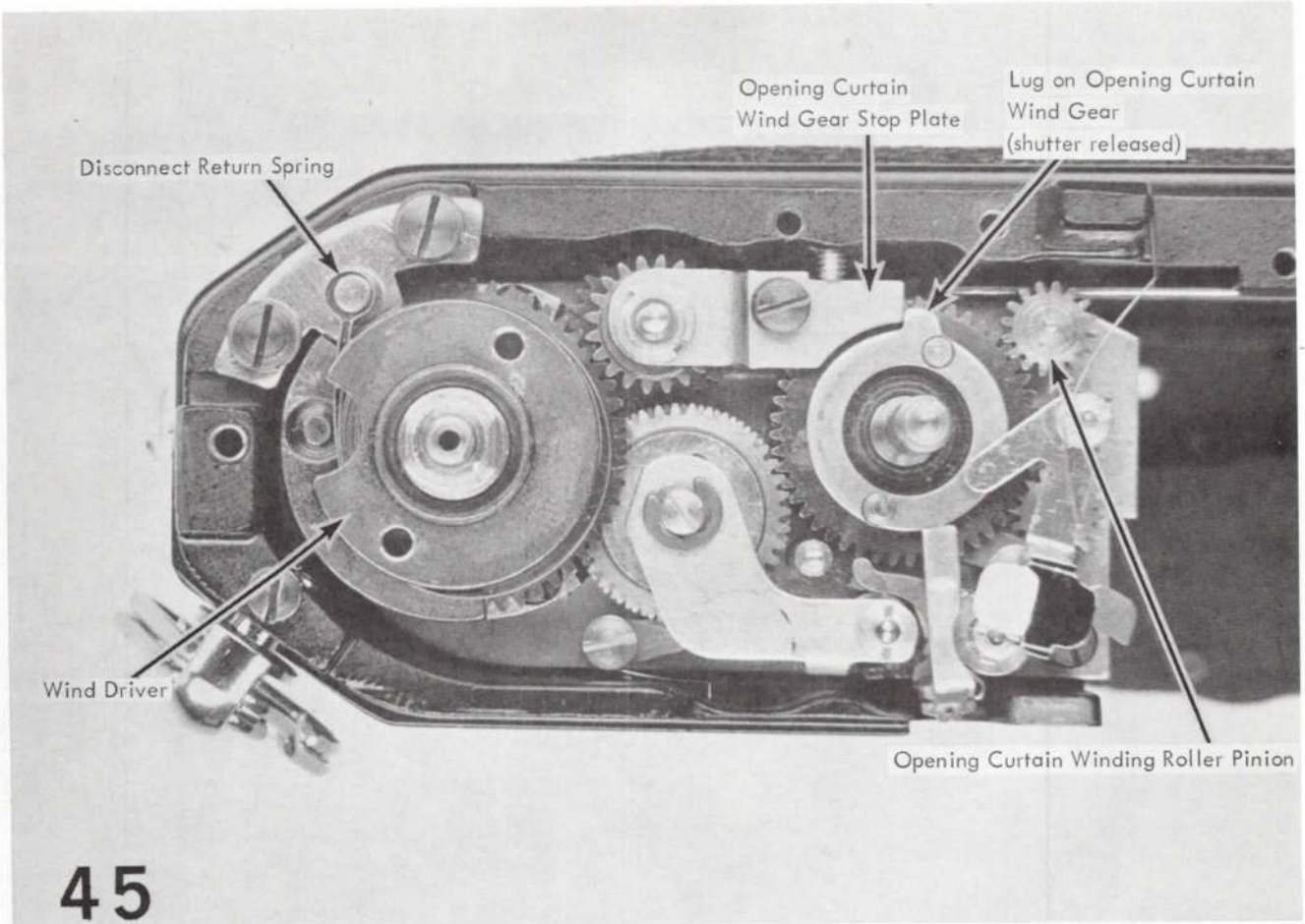

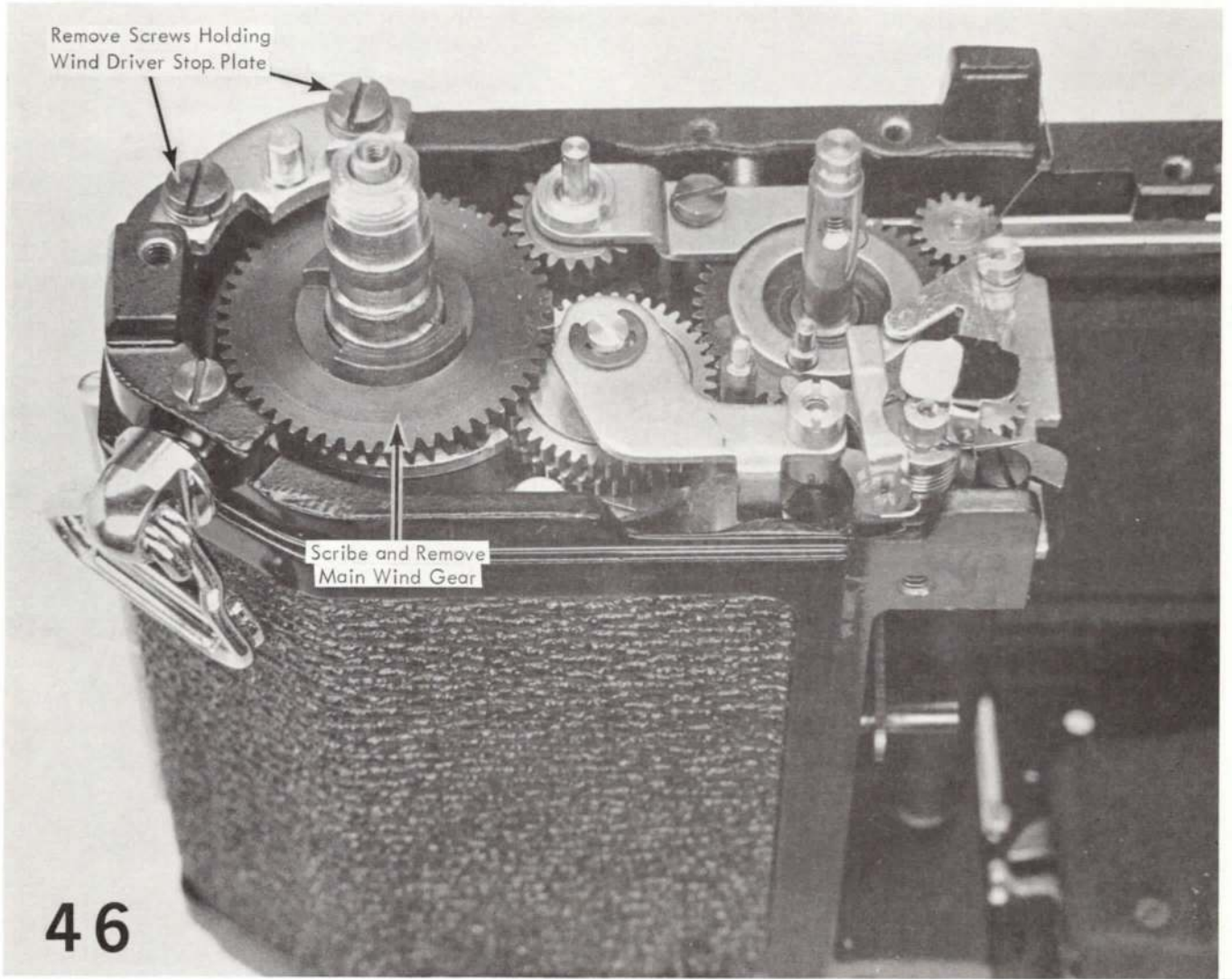

Remove Screws Holding  
Wind Driver Stop. Plate

Scribe and Remove  
Main Wind Gear

46

Remove Screws  
Holding Wind  
Column

Warning Flag  
Retaining Nut

Remove Release  
Plunger E-Ring

Unscrew Release Rod

47

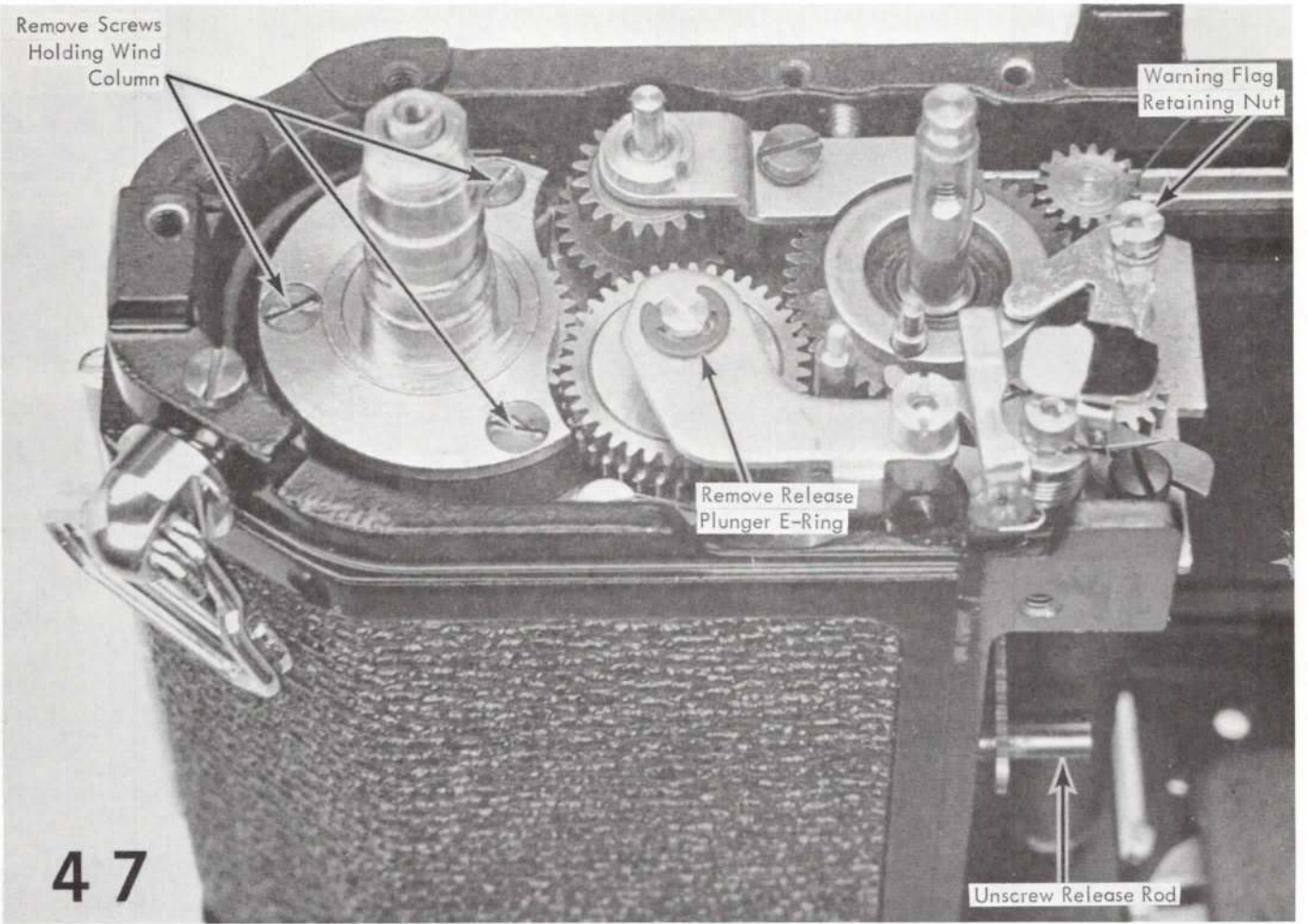

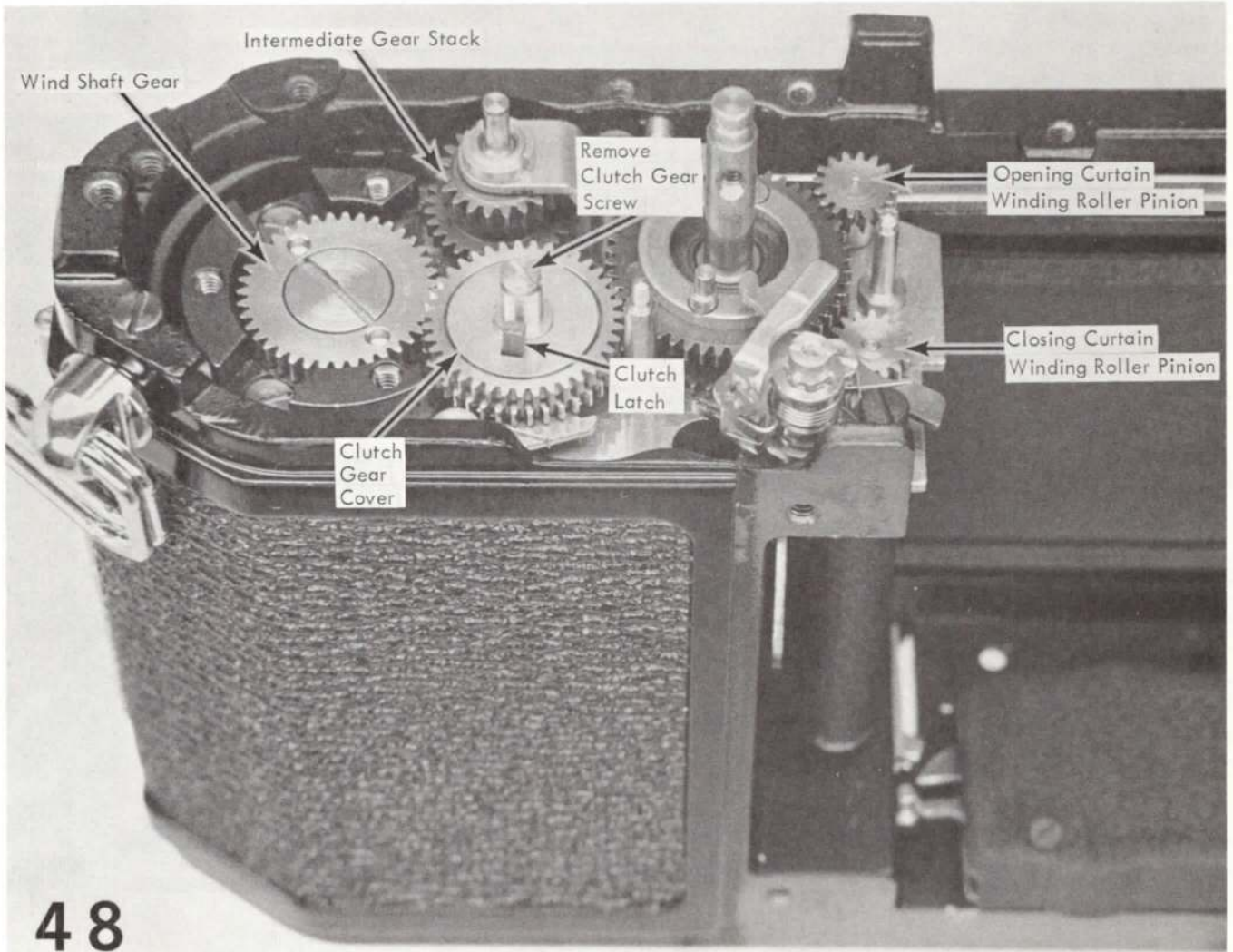

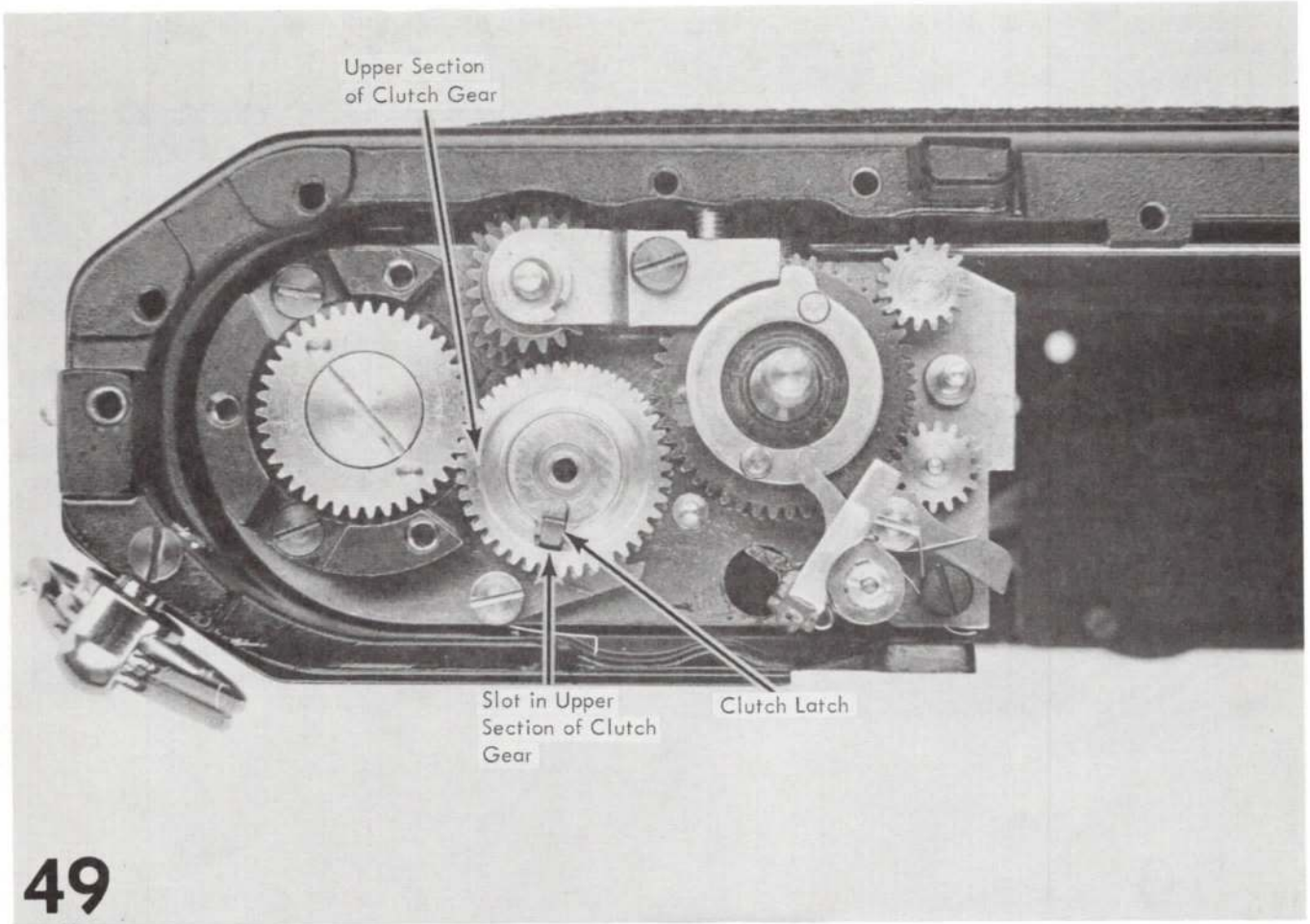

49

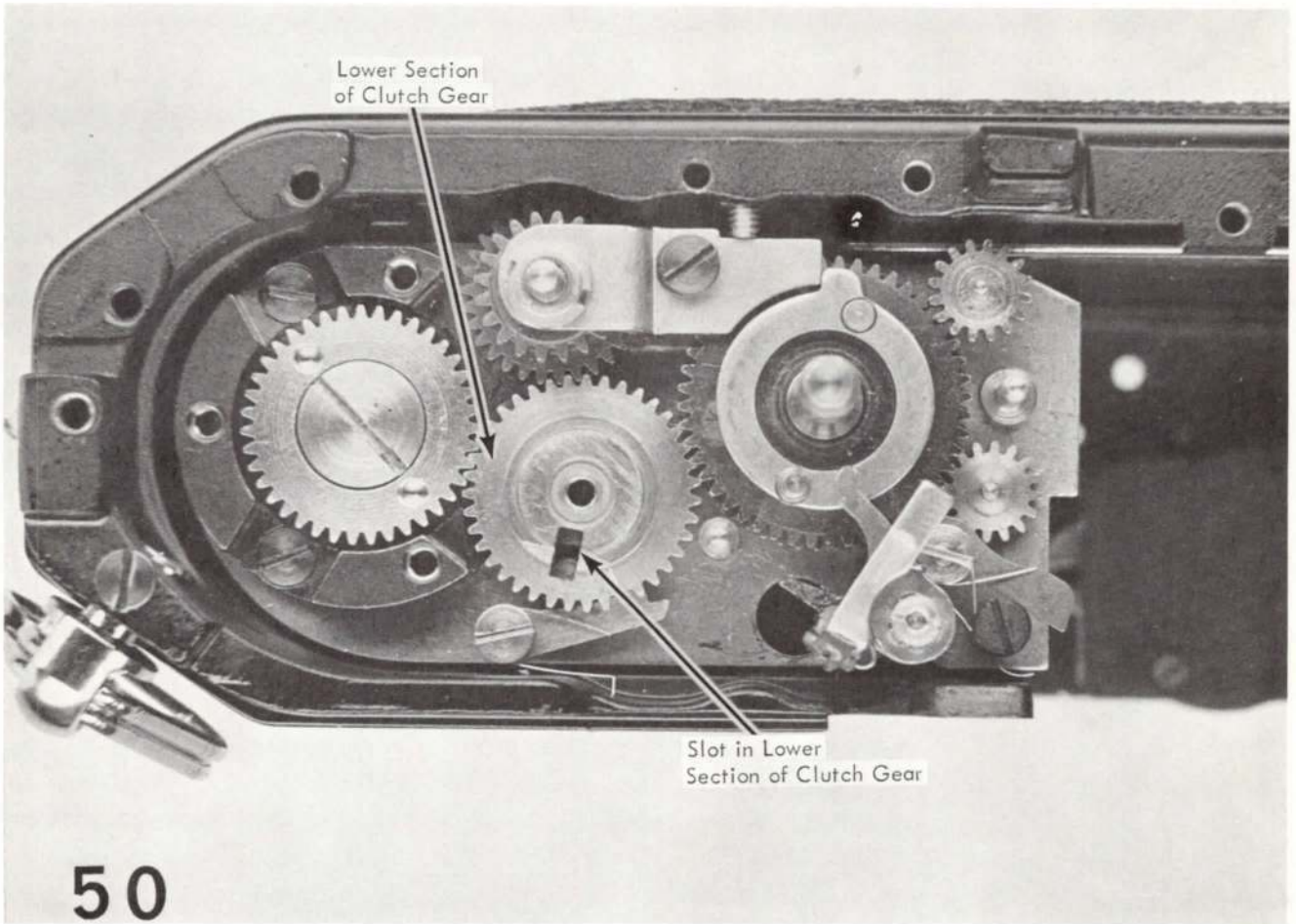

Lower Section  
of Clutch Gear

Slot in Lower  
Section of Clutch Gear

50

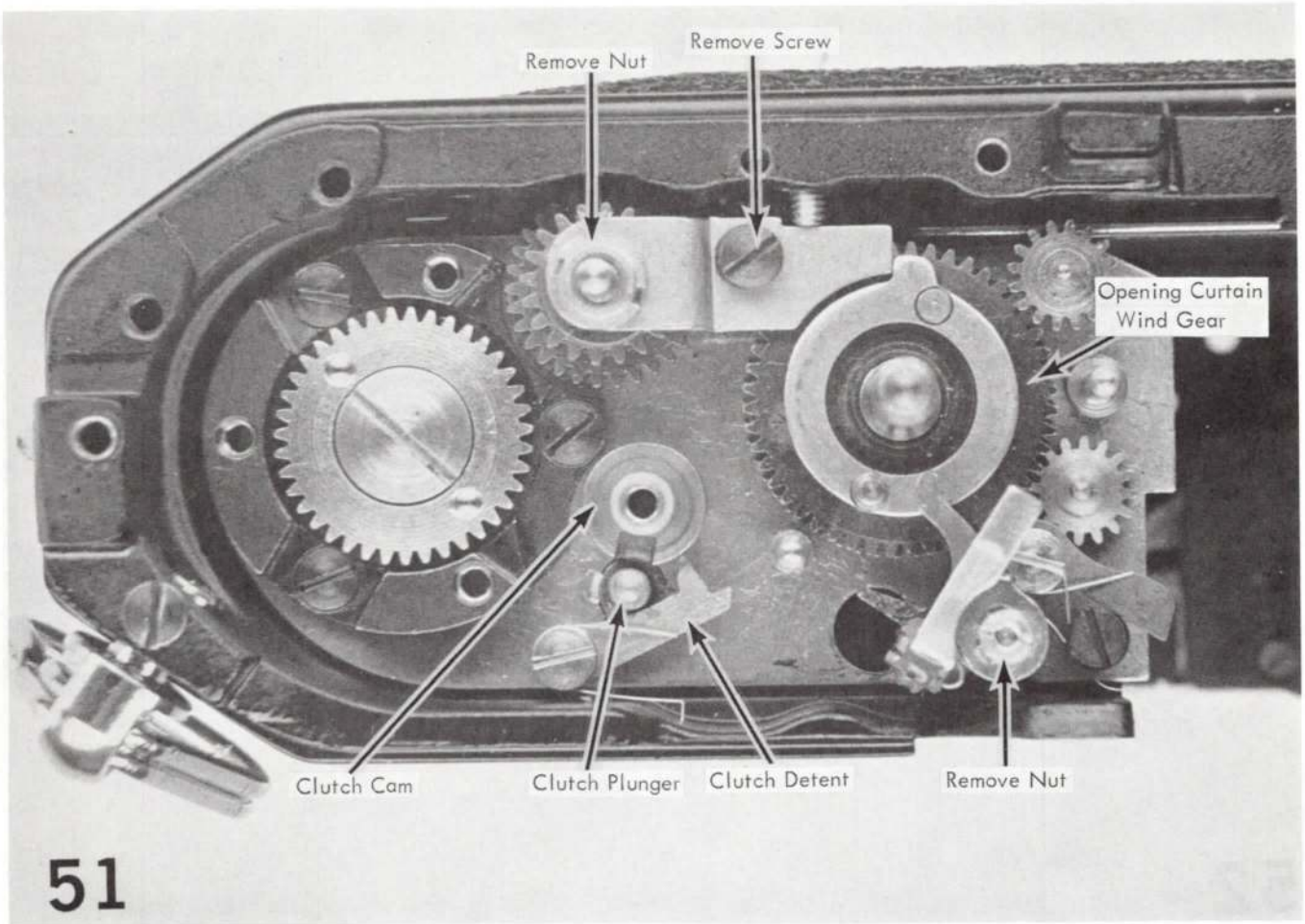

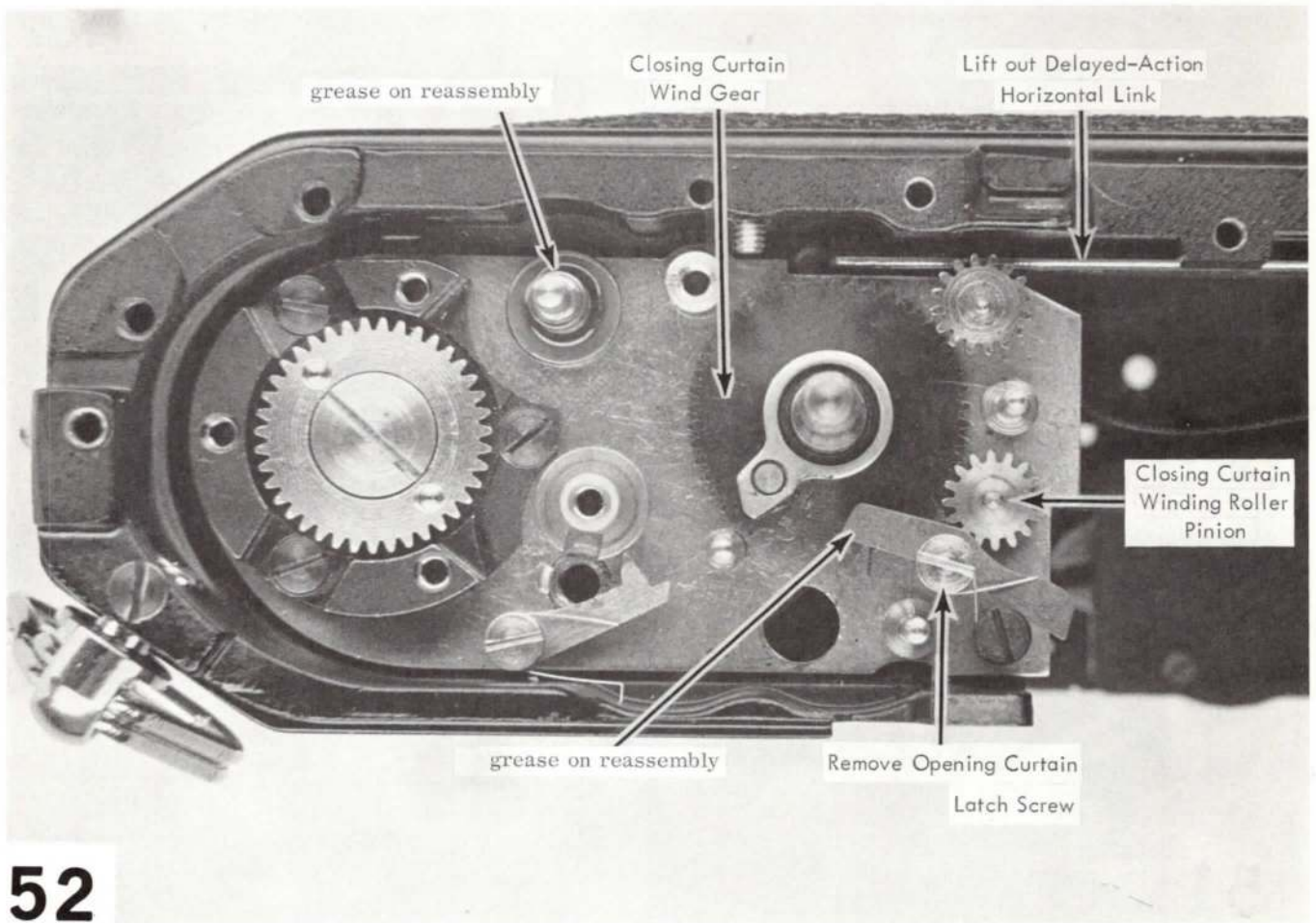

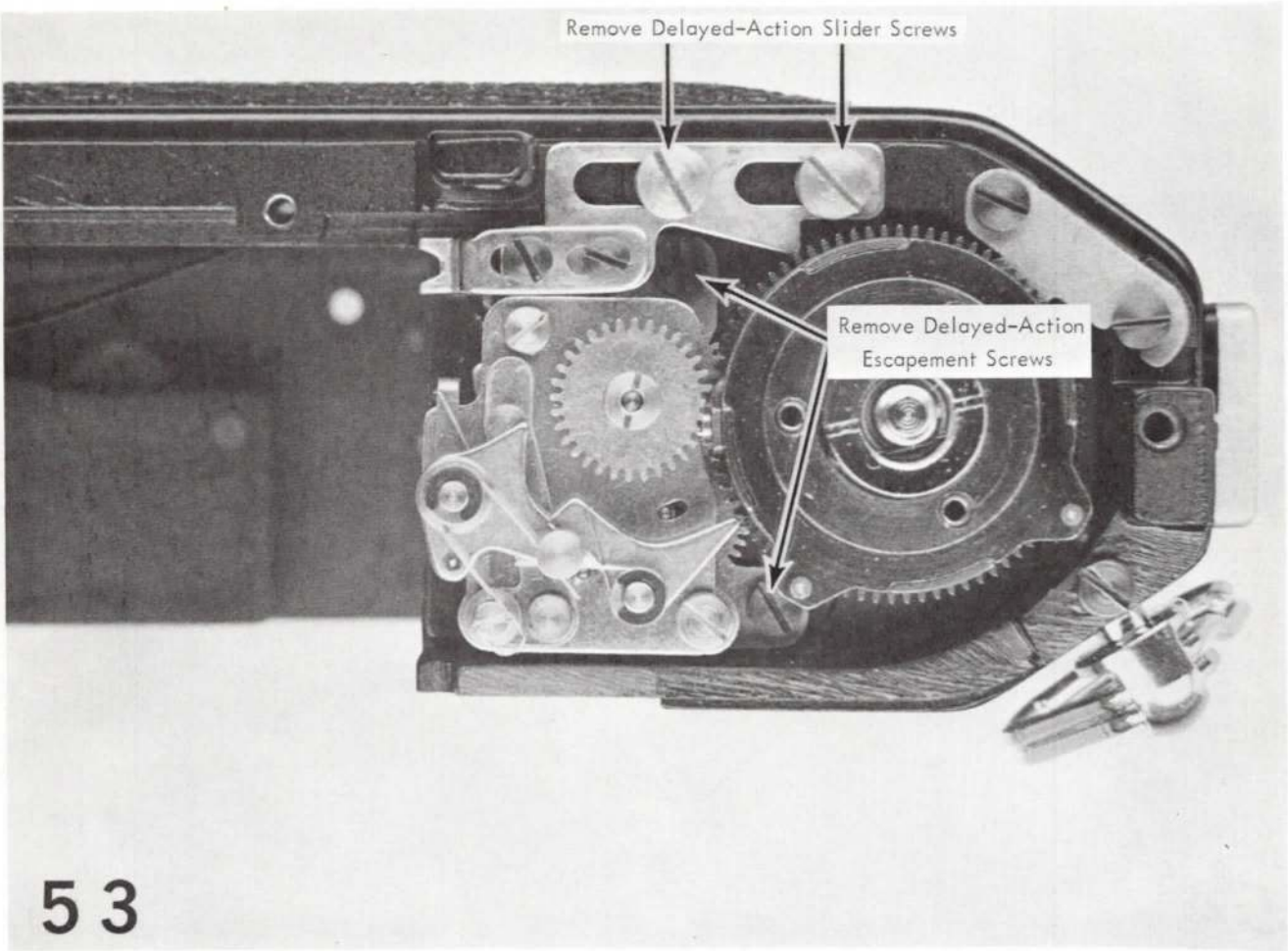

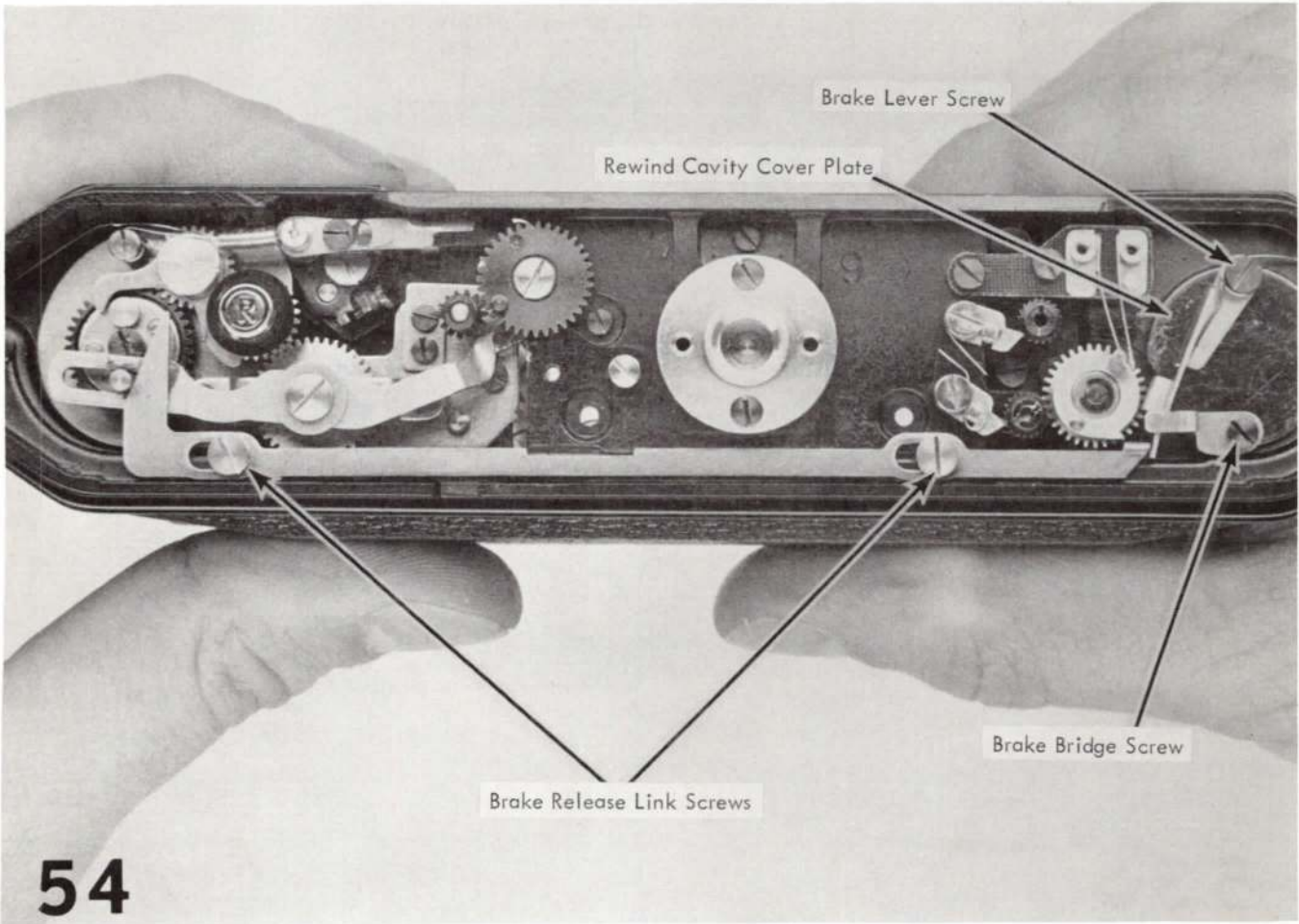

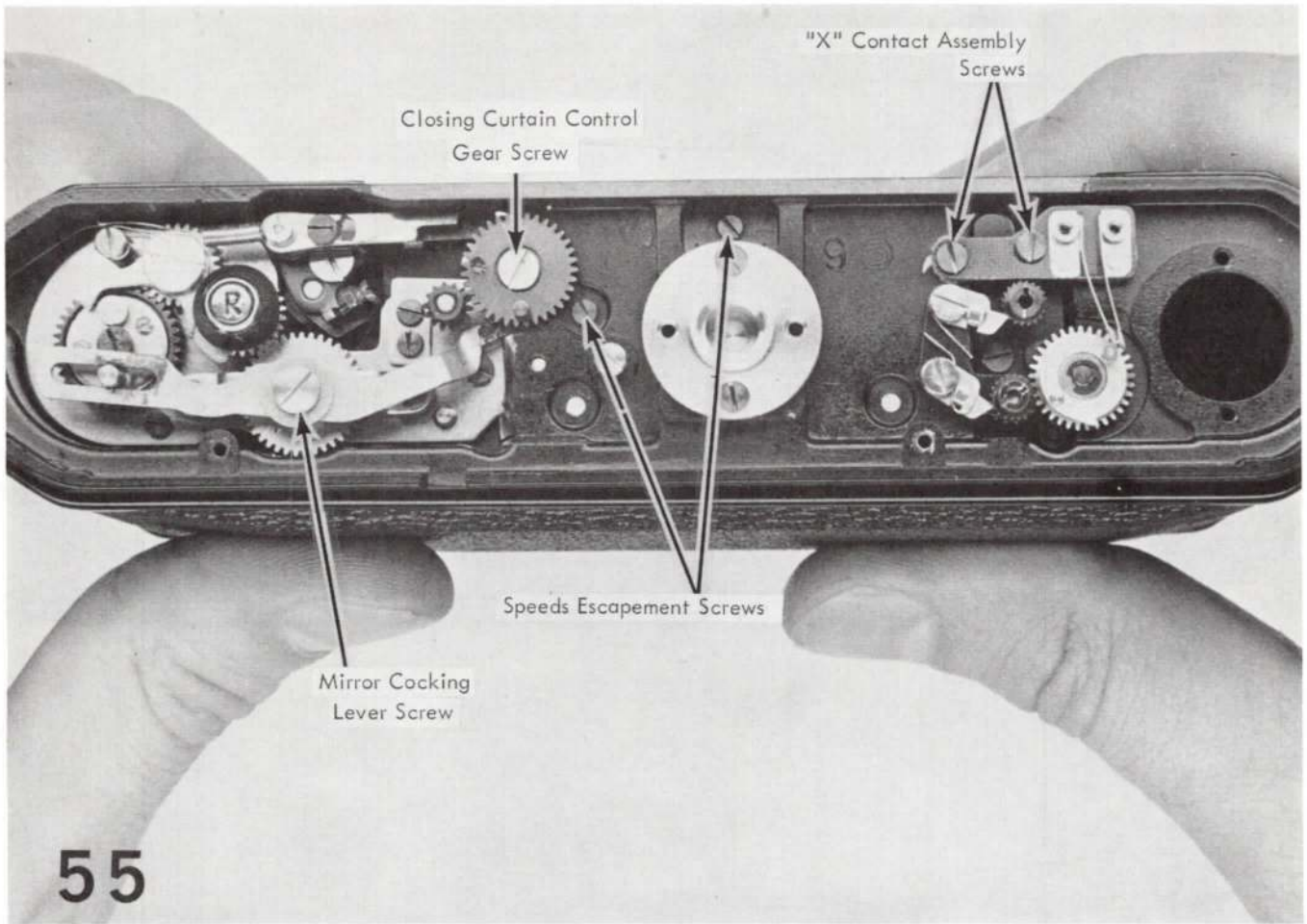

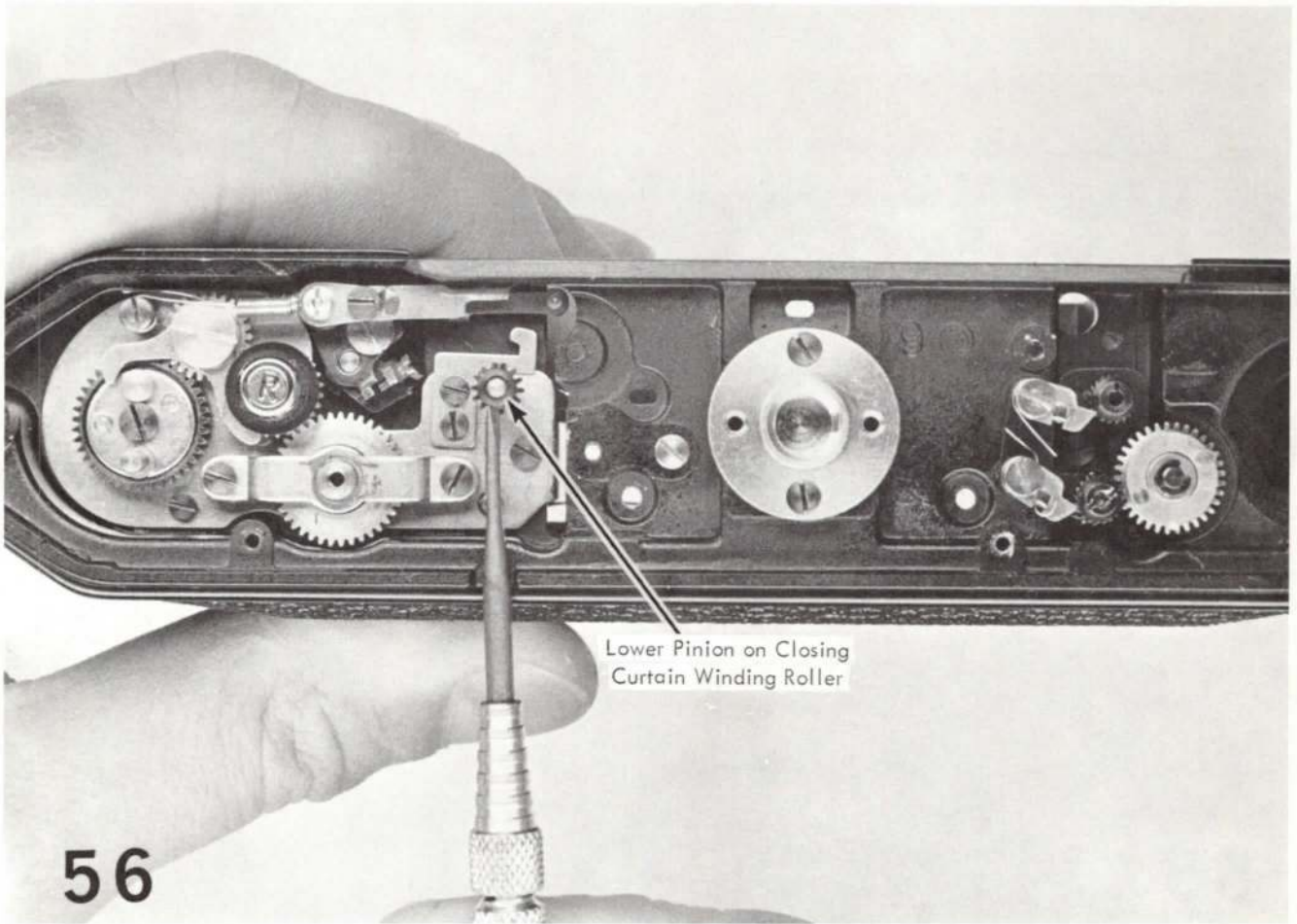

Lower Pinion on Closing  
Curtain Winding Roller

56

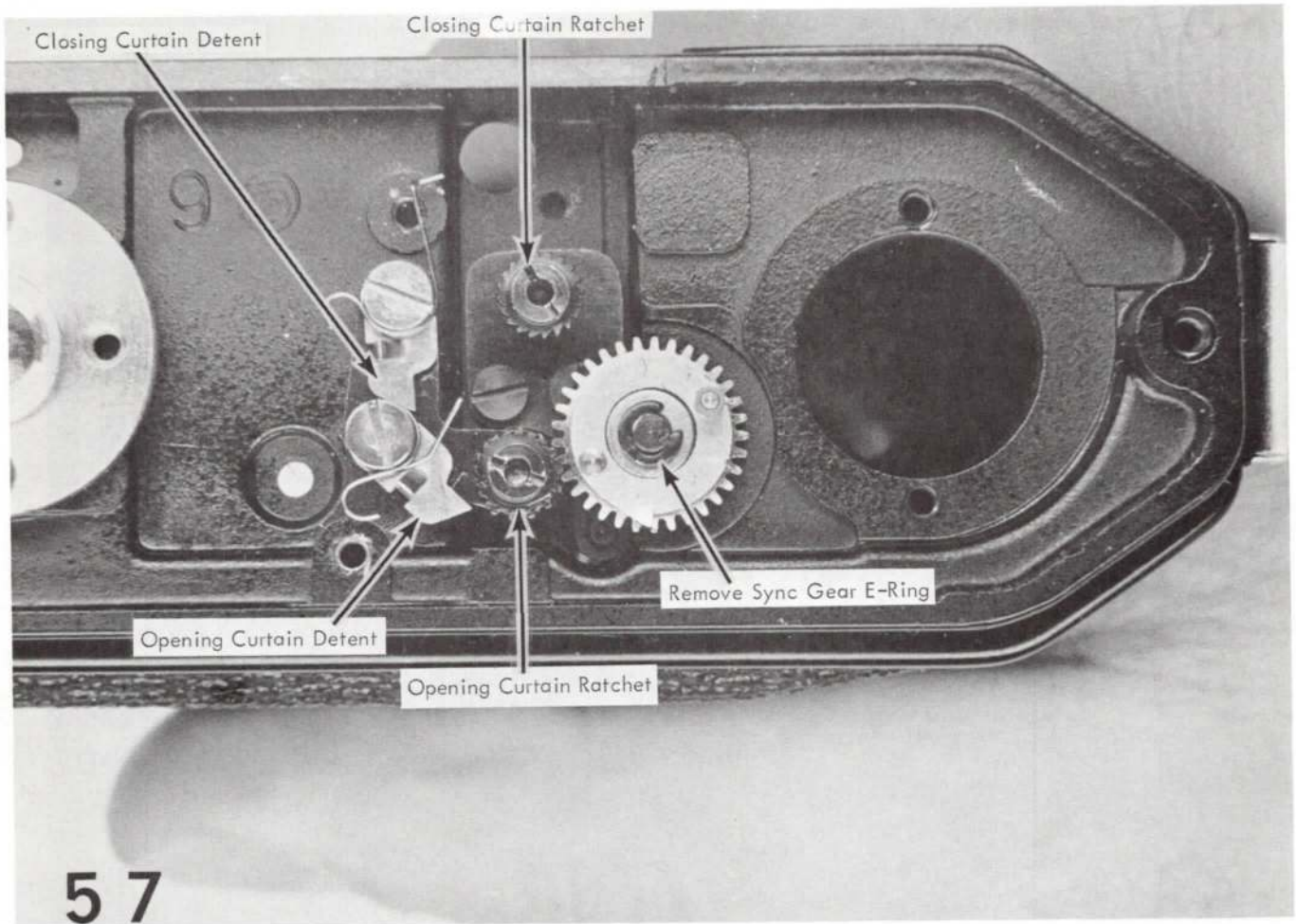

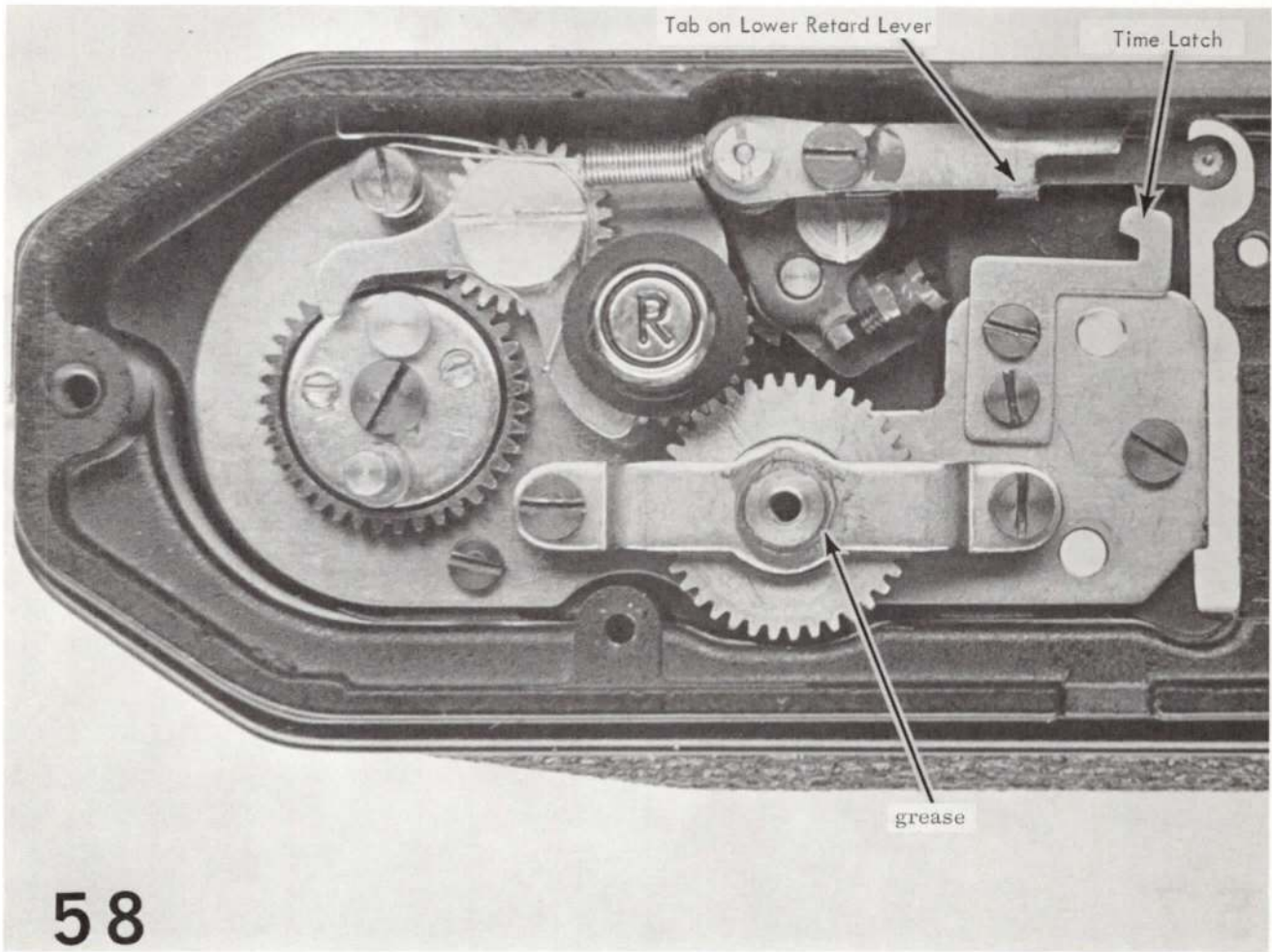

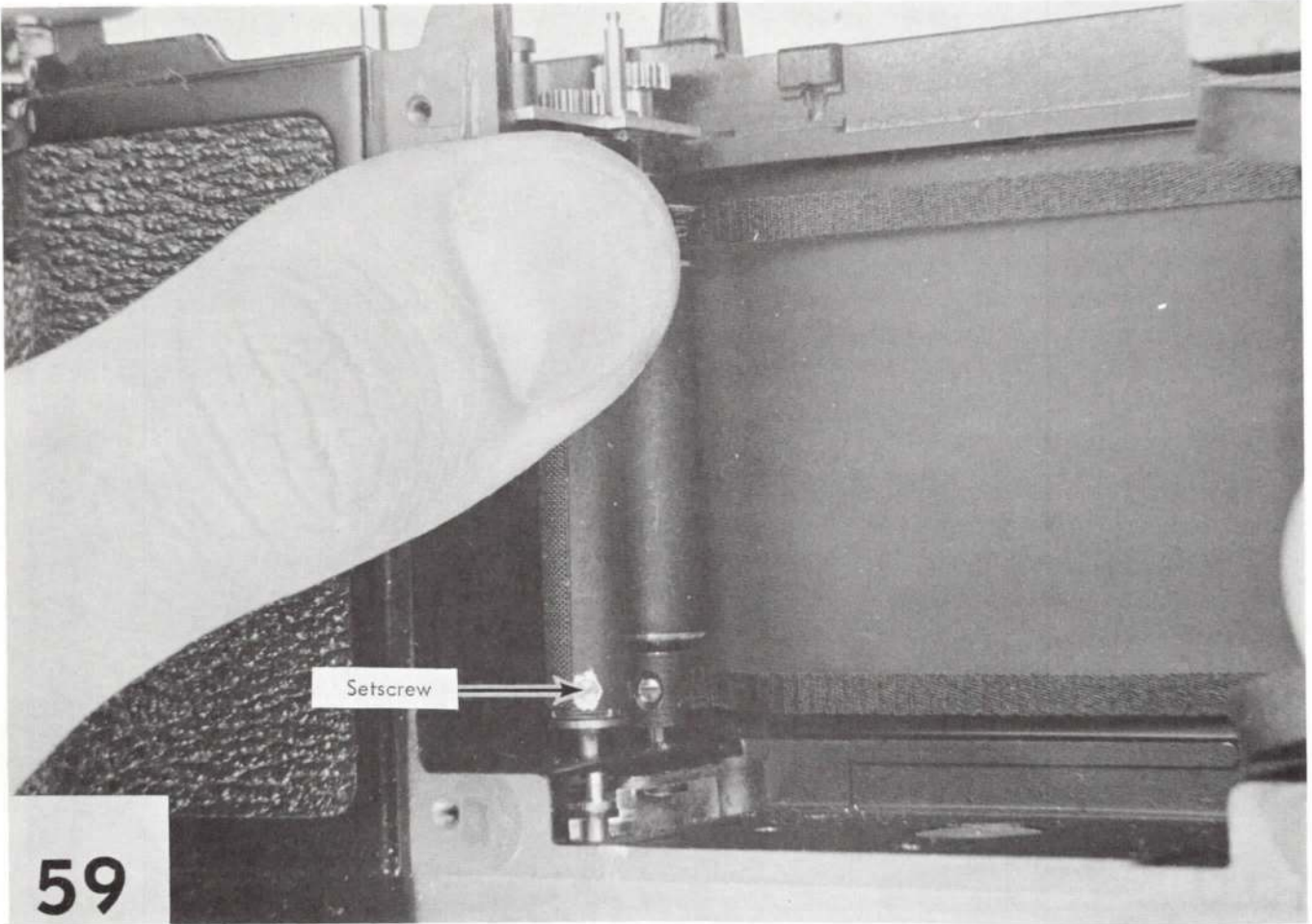

59

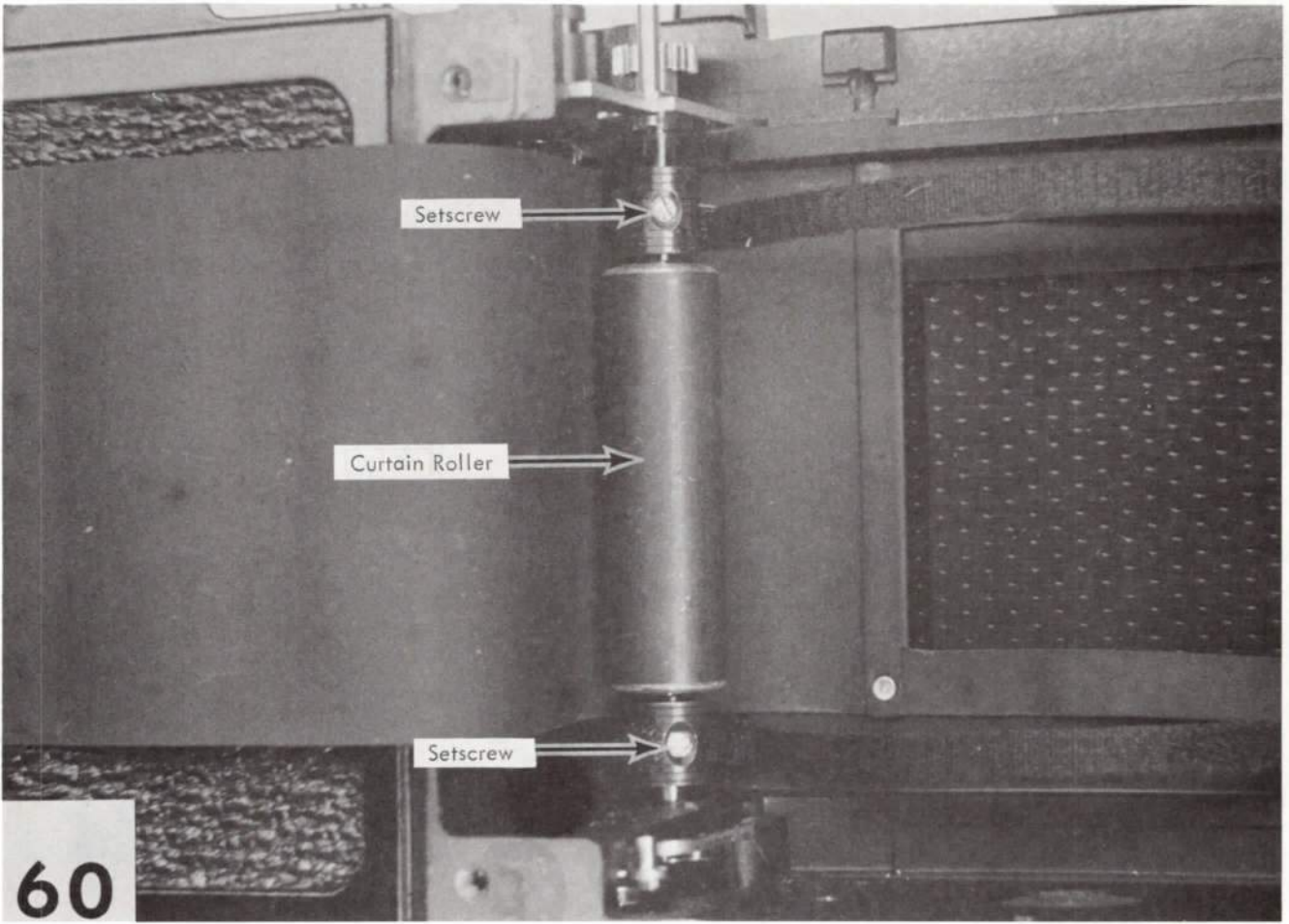

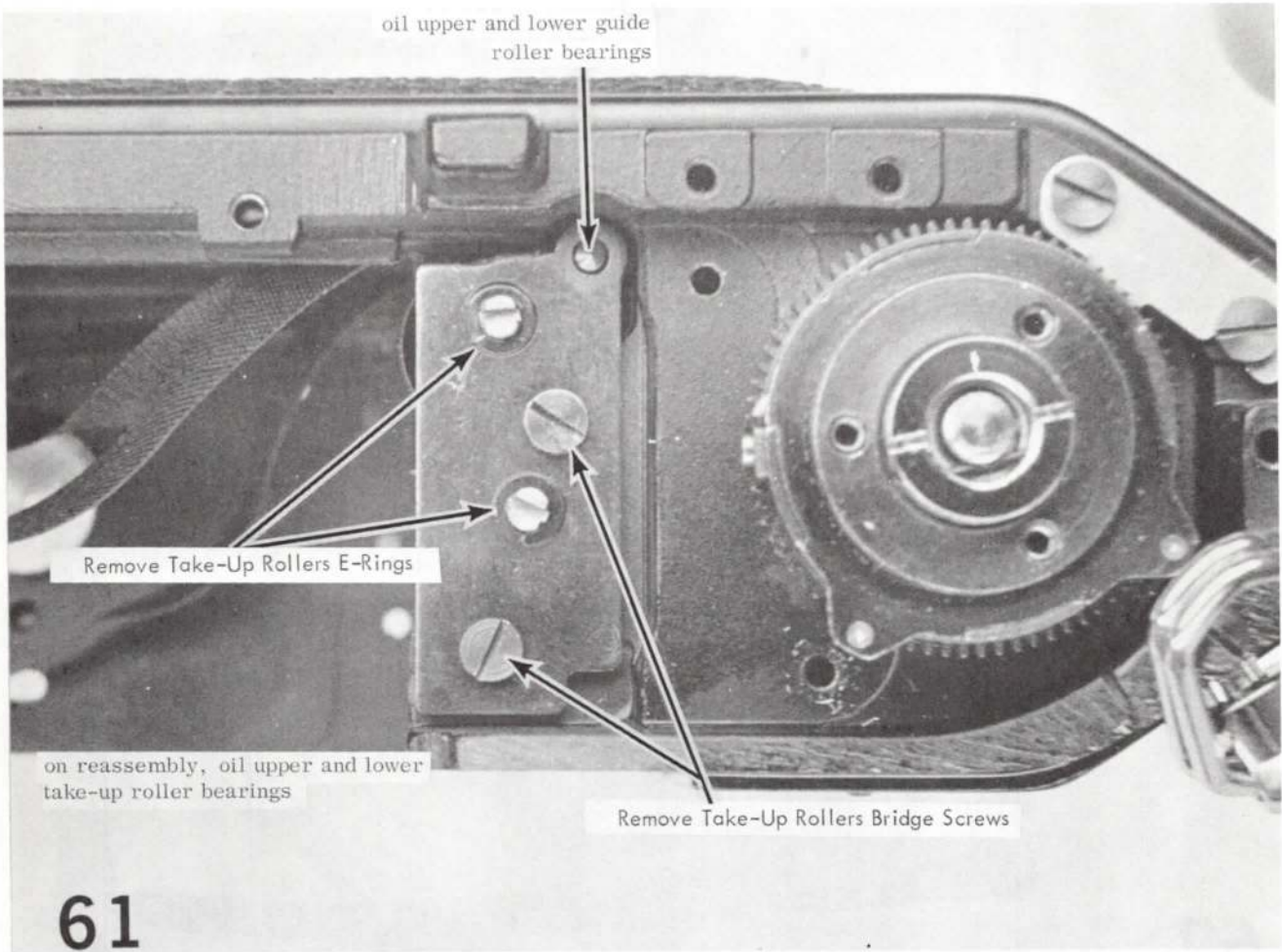

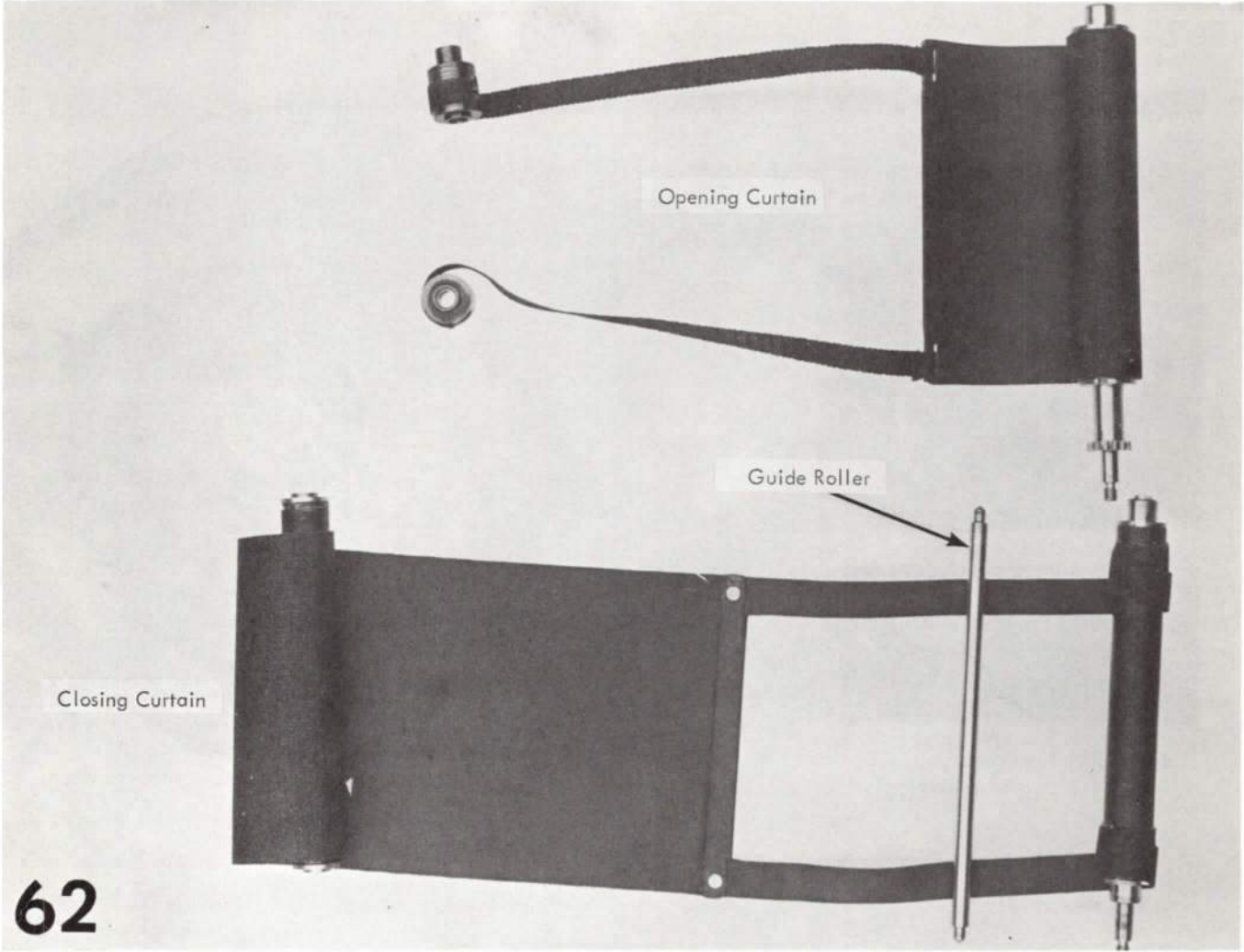

Opening Curtain

Closing Curtain

Guide Roller

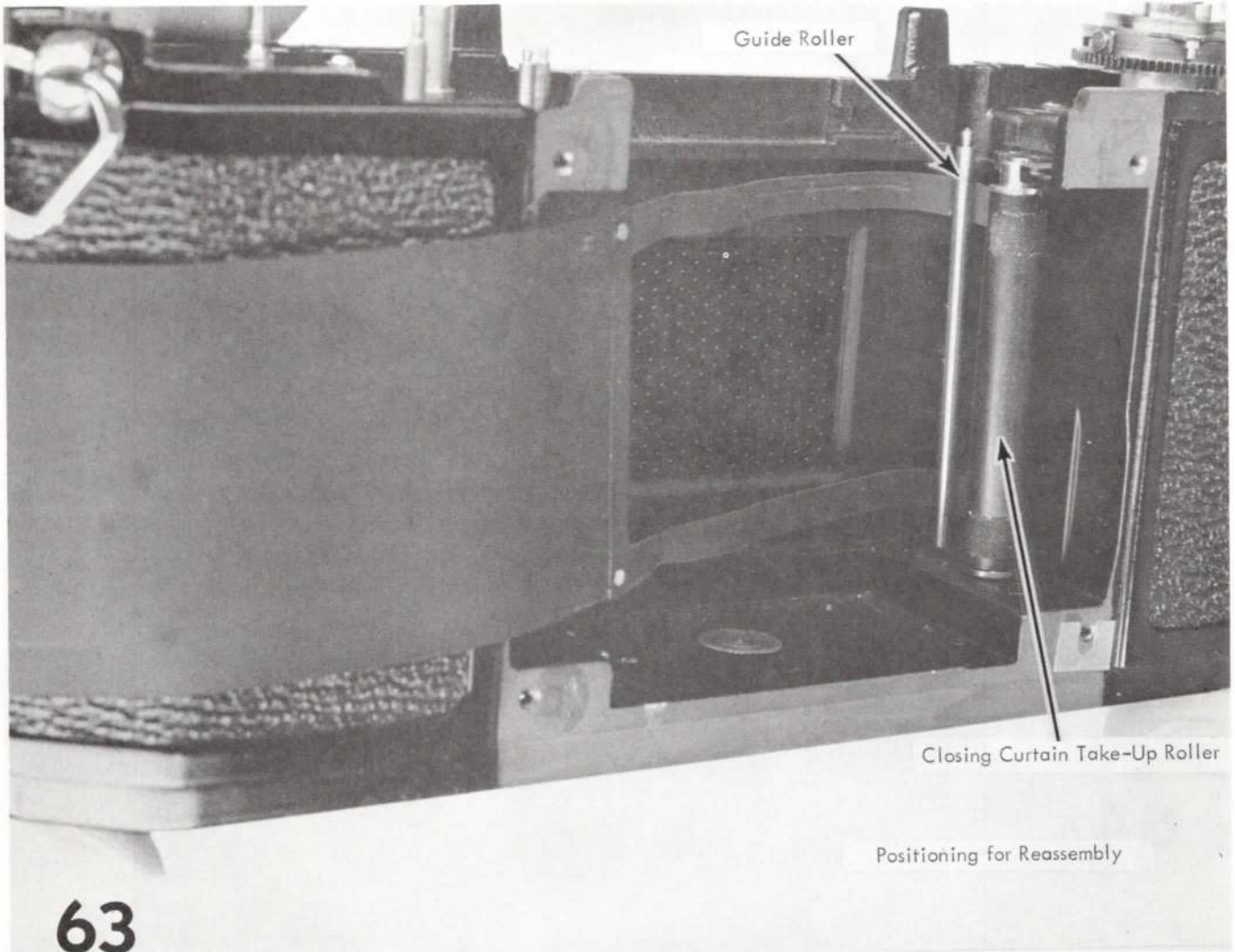

Guide Roller

Closing Curtain Take-Up Roller

Positioning for Reassembly

63

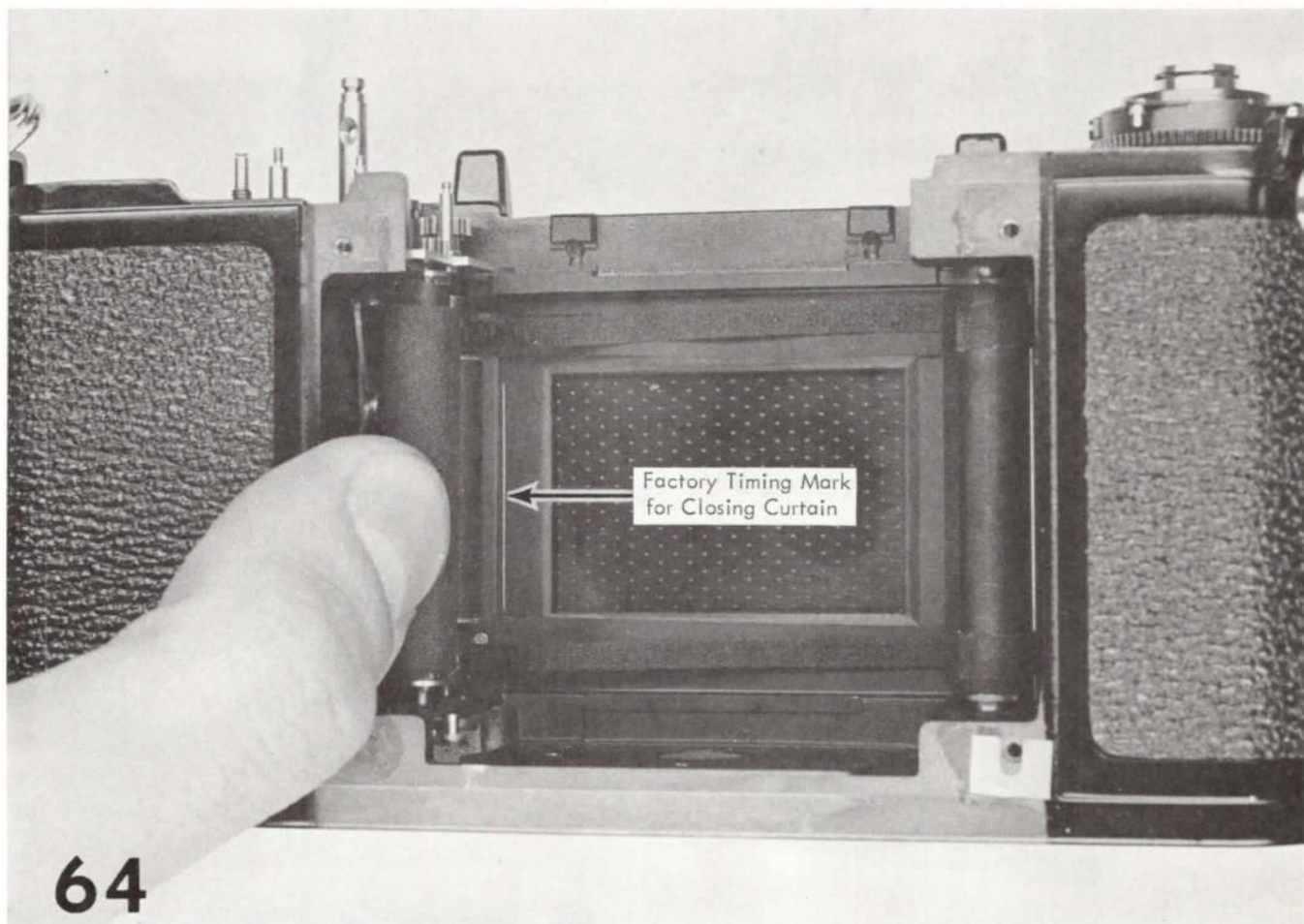

Factory Timing Mark  
for Closing Curtain

64

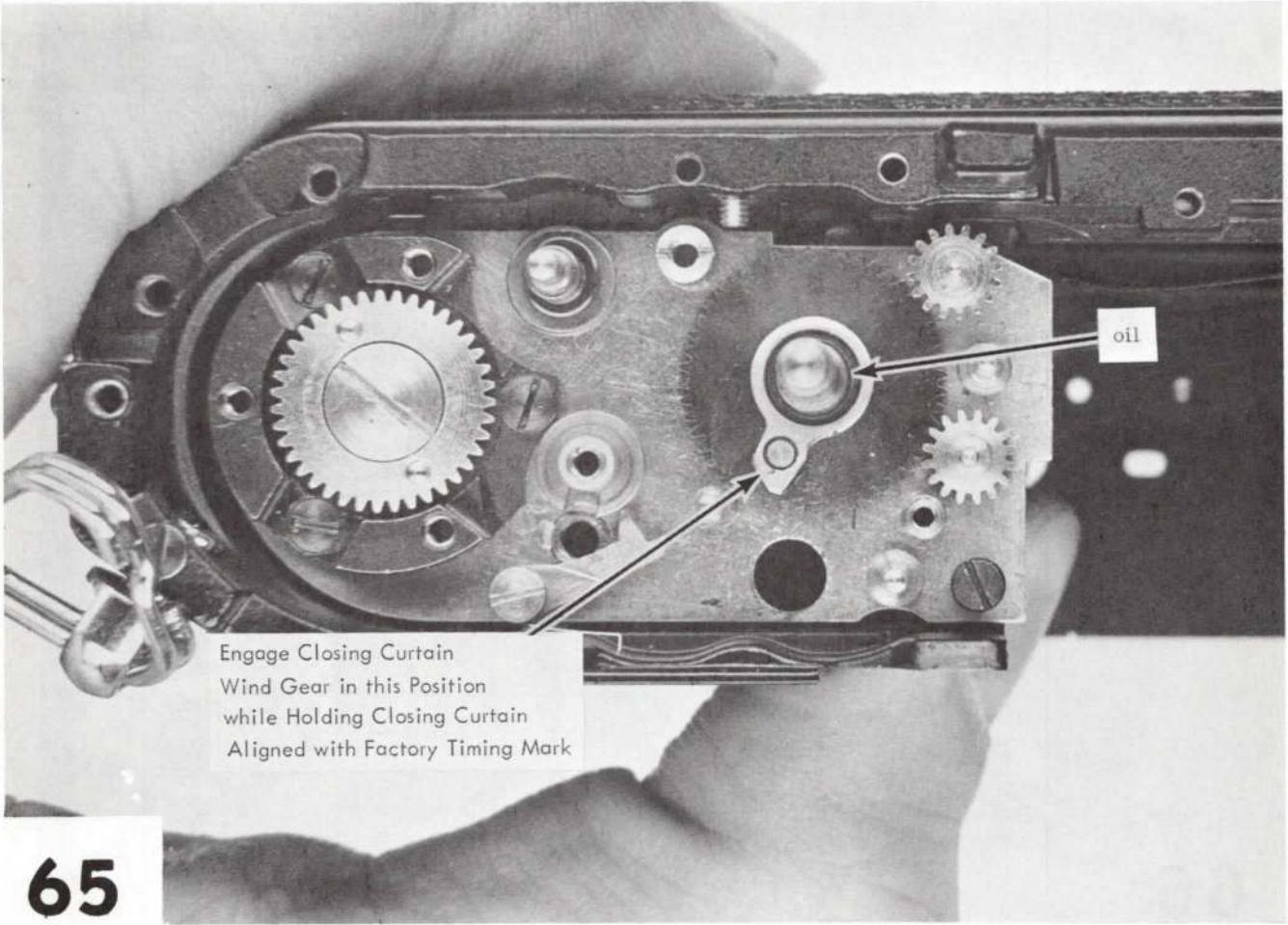

Engage Closing Curtain  
Wind Gear in this Position  
while Holding Closing Curtain  
Aligned with Factory Timing Mark

65

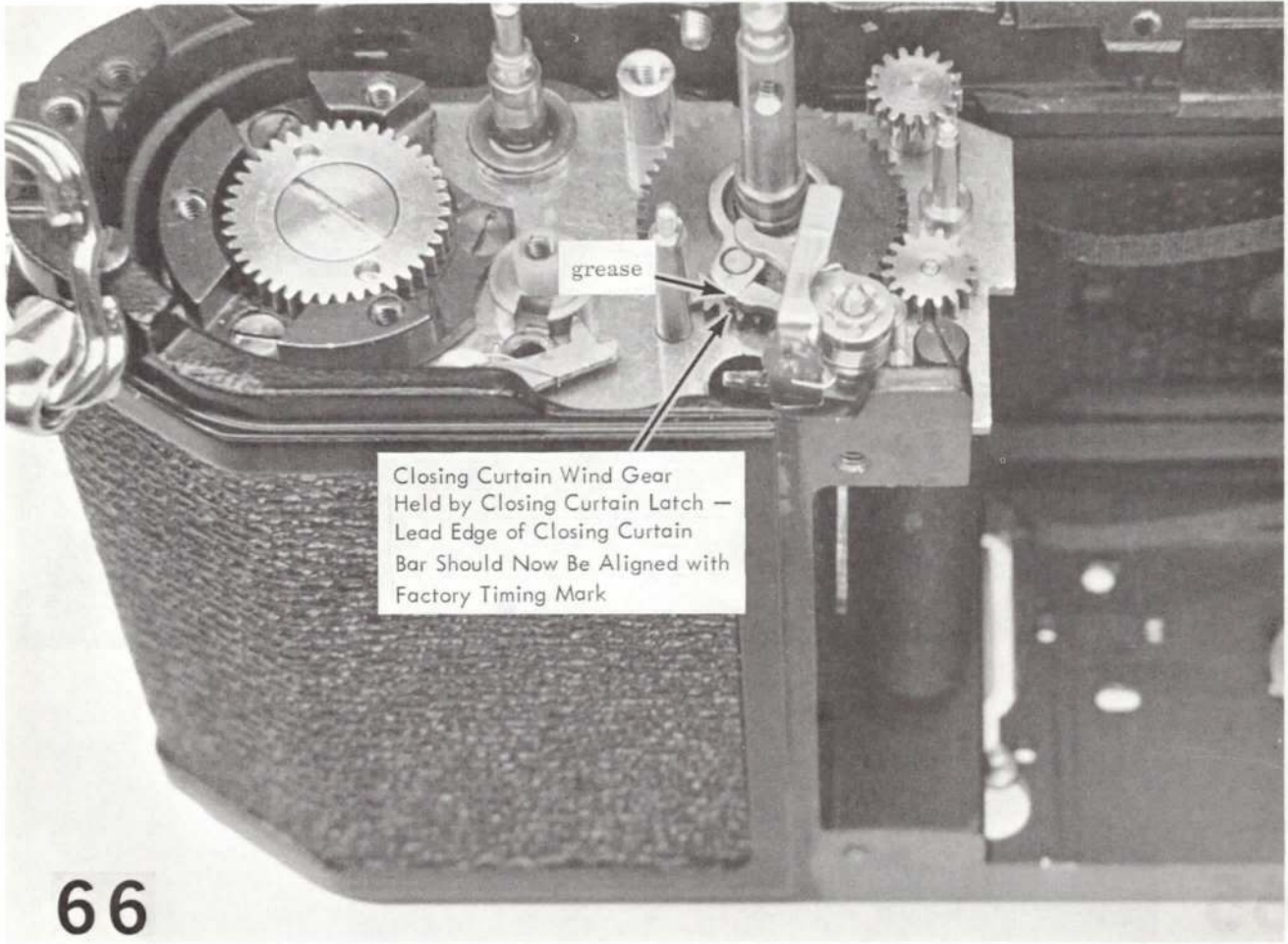

grease

Closing Curtain Wind Gear  
Held by Closing Curtain Latch —  
Lead Edge of Closing Curtain  
Bar Should Now Be Aligned with  
Factory Timing Mark

66

Engage Opening Curtain Wind Gear in  
this Position — Adjust Timing between  
Opening Curtain Wind Gear and Opening  
Curtain Winding Roller Pinion for  
One Bar Overlap

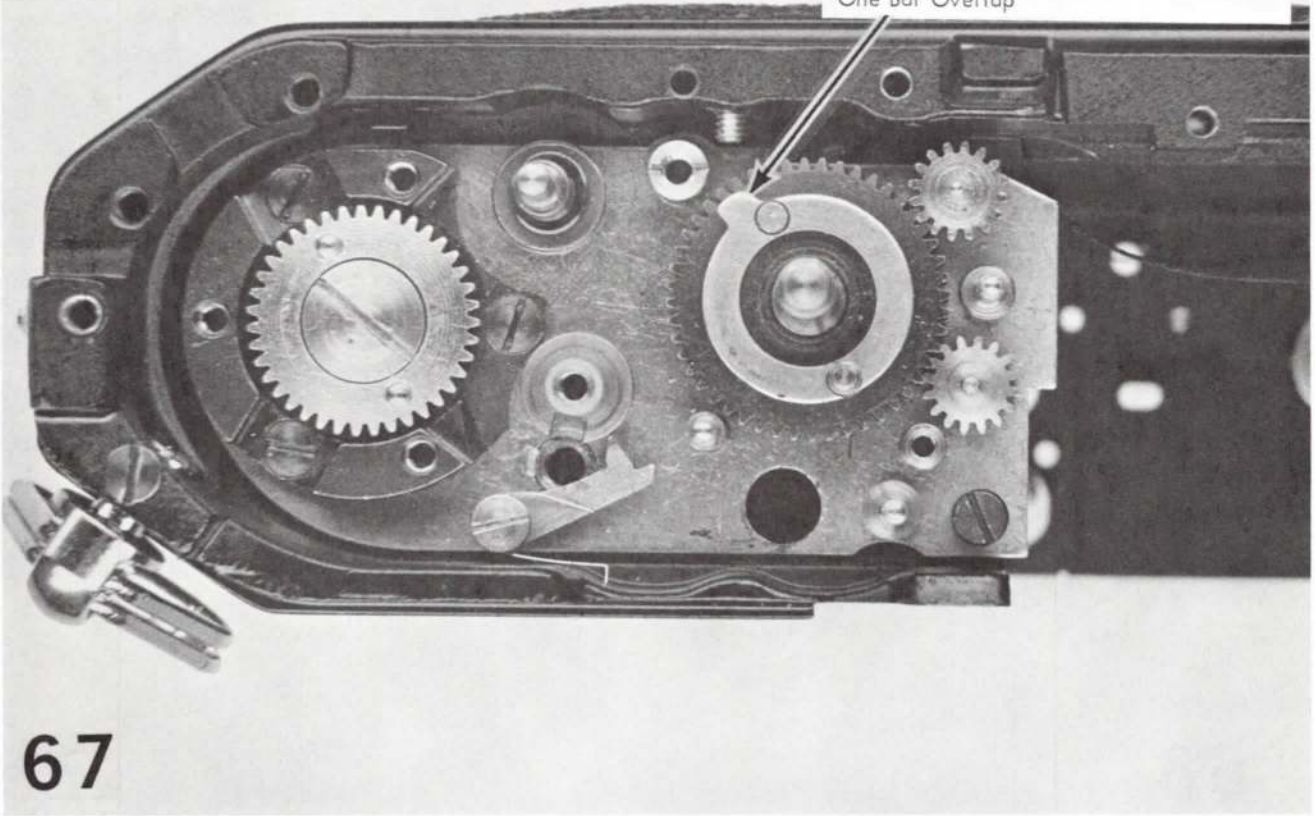

67

Note Disassembly Illustrations for Proper Timing of Clutch Gear — Install Wind Driver and Hook Return Spring as Shown

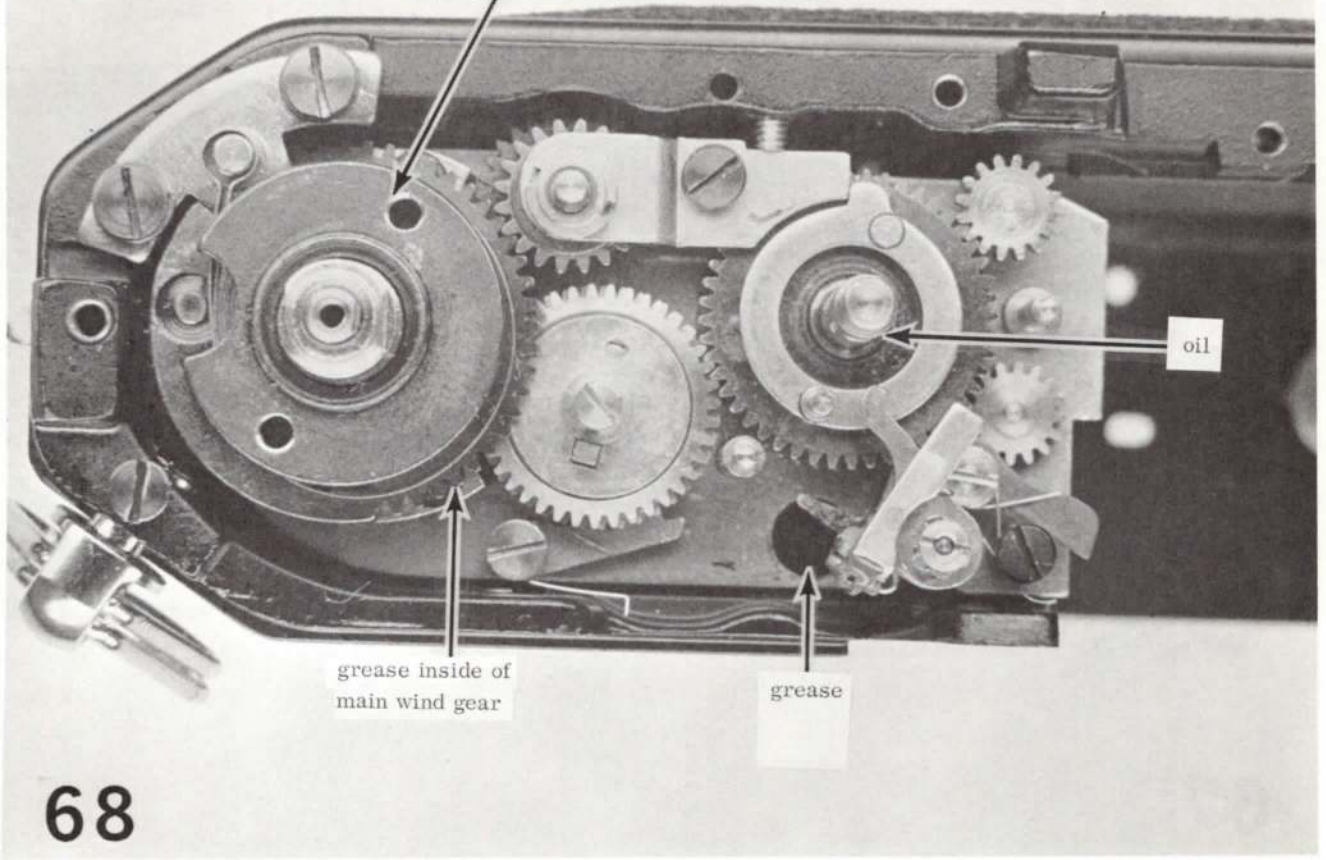

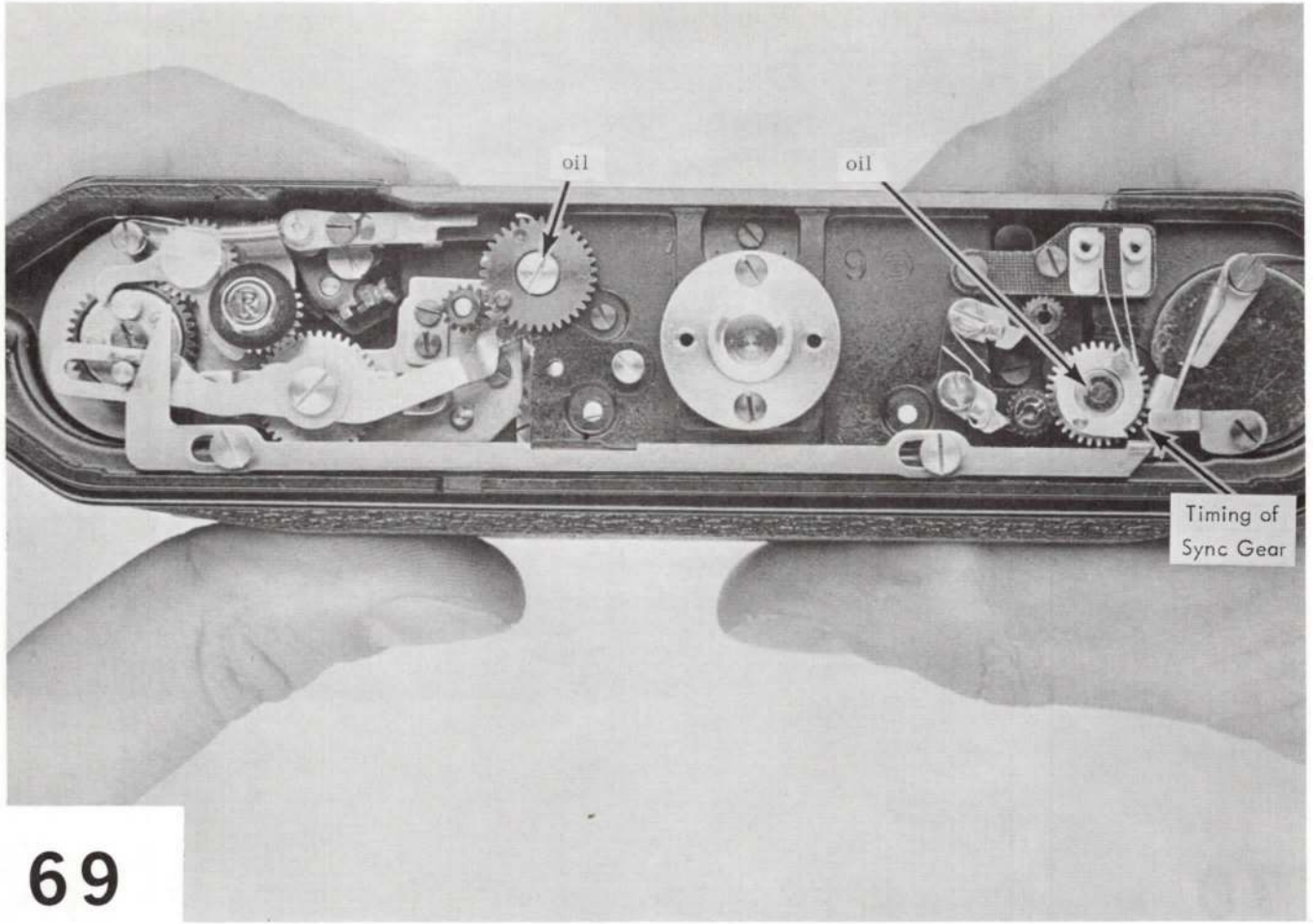

69

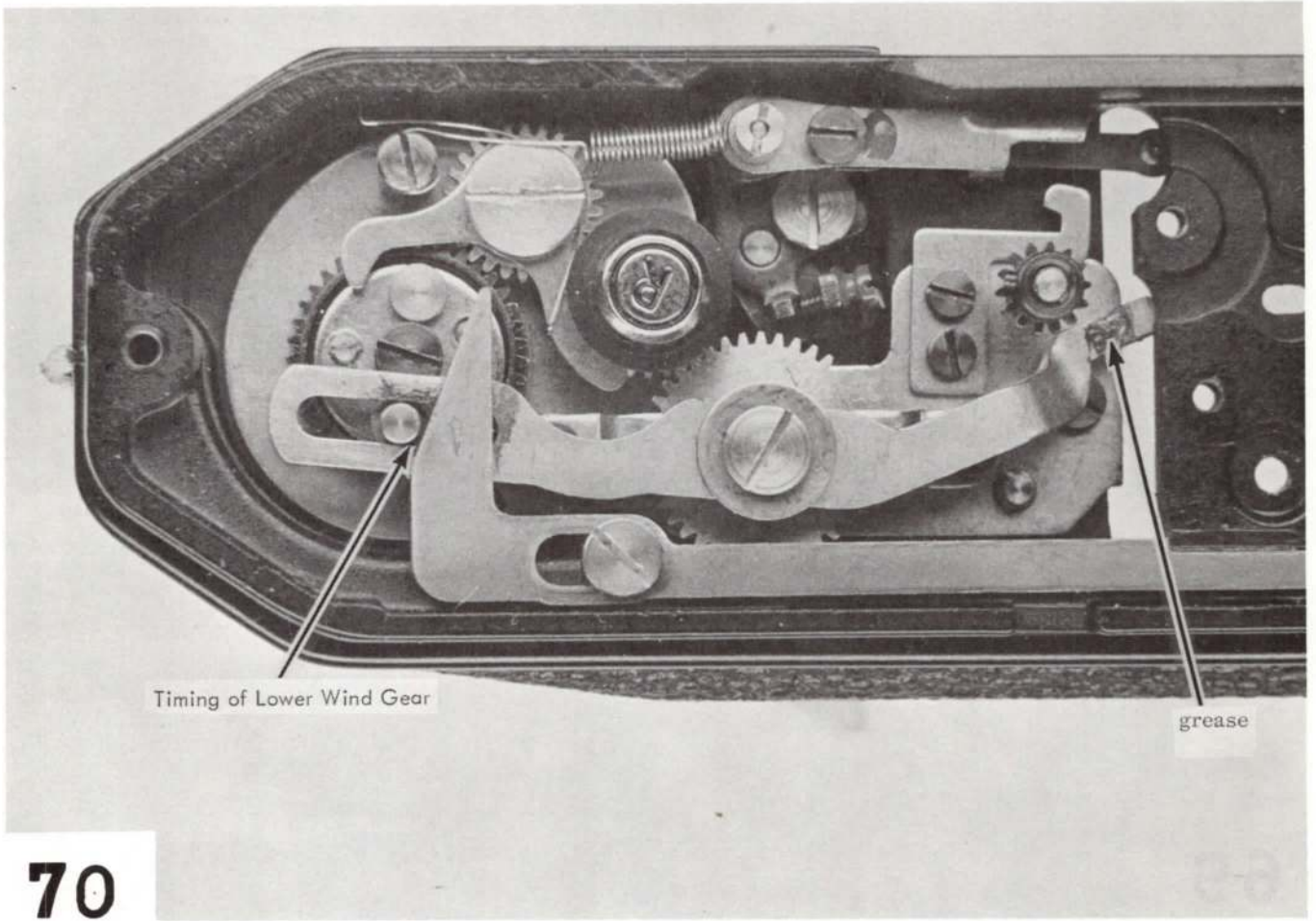

Timing of Lower Wind Gear

grease

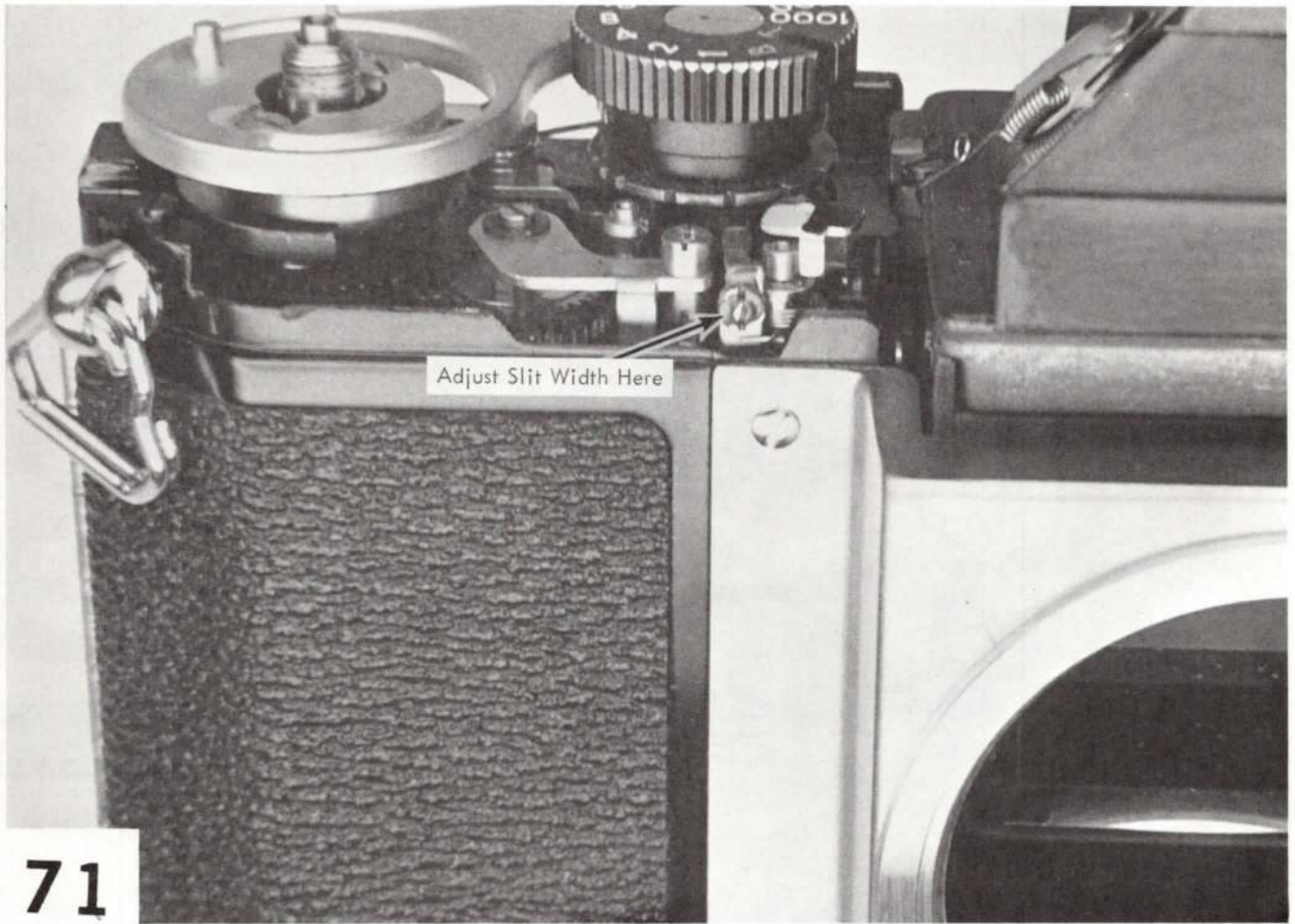

Adjust Slit Width Here

71

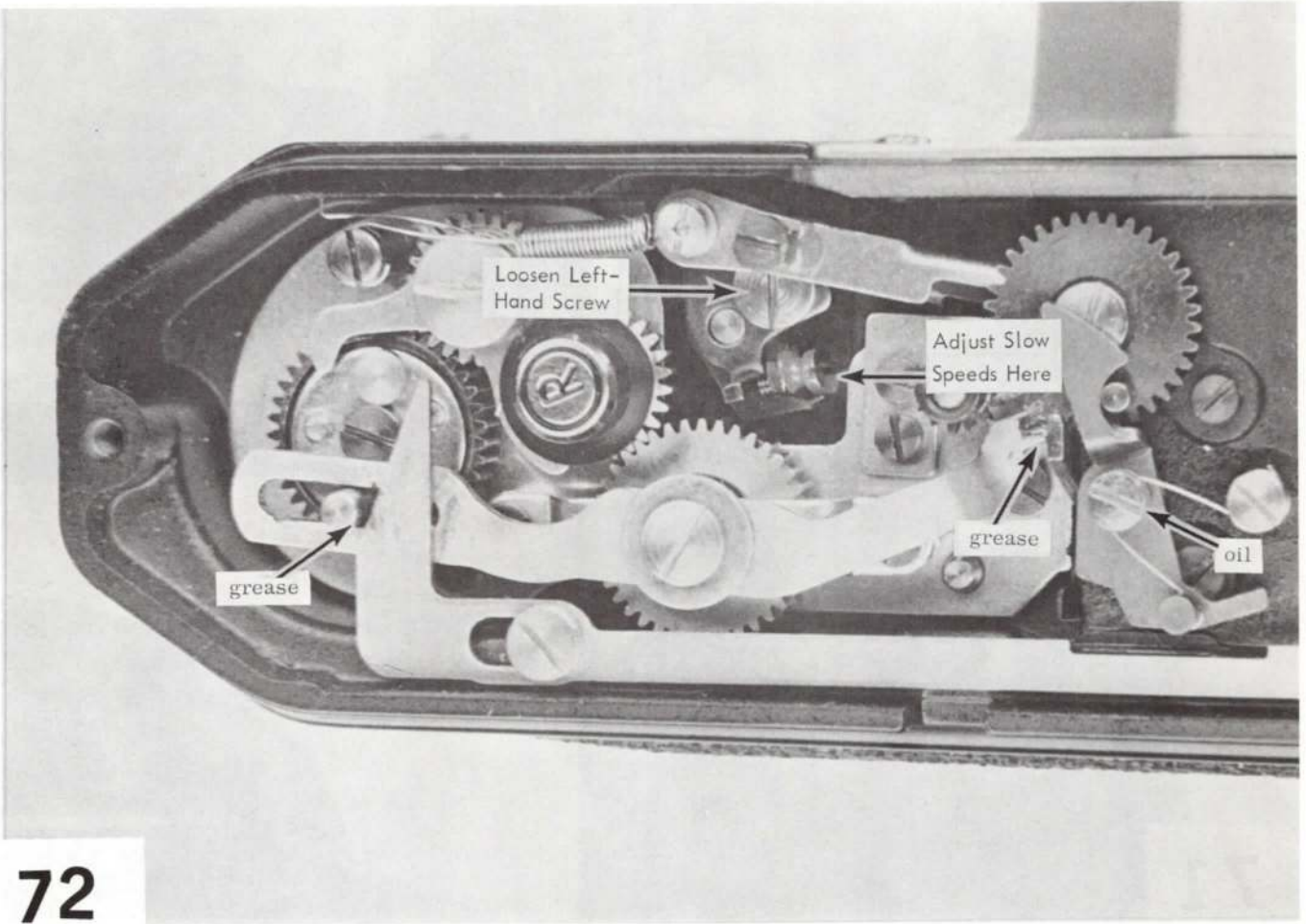

72