

THE HONEYWELL

THE CAMERA CRAFTSMAN appreciates the cooperation of Honeywell Photo Products, Inc.

These days, it's easy to get the attention of a camera enthusiast — just mention the Pentax ES. The widely acclaimed ES signifies more than another new camera model — it's a major design breakthrough.

Why? Because the Pentax ES is the first SLR to offer fully automatic exposure control with an electronic shutter.

One SLR feature held back earlier SLR designs in trying to combine through-the-lens metering with automatic shutter-speed control: The mirror flips up to the viewing position prior to the exposure. Once the mirror reaches the viewing position, the photocells can no longer see the light coming through the lens.

So enterprising Pentax engineers developed the first "memory" circuit. The memory circuit calculates the exposure data as you start depressing the release button. Pushing the release button a little further triggers the mirror.

Now, the mirror starts its climb to the taking position. At the beginning of its travel, the mirror opens the memory-circuit switch — that latches in the exposure data. Continuing in its travel, the mirror releases the shutter.

By then, the CdS cells can no longer see the light coming through the lens. But it doesn't matter — the memory circuit has already recorded the proper exposure.

As in most electronically controlled cameras, the Pentax ES uses the aperture-preferred metering system. "Aperture-preferred" is a term that's become fashionable to distinguish between cameras that set the shutter speed automatically (aperture-preferred) and those that set the diaphragm opening automatically (shutter-speed preferred).

Anyway, "aperture-preferred" simply means that you select the diaphragm opening you want. The camera then takes the lens aperture

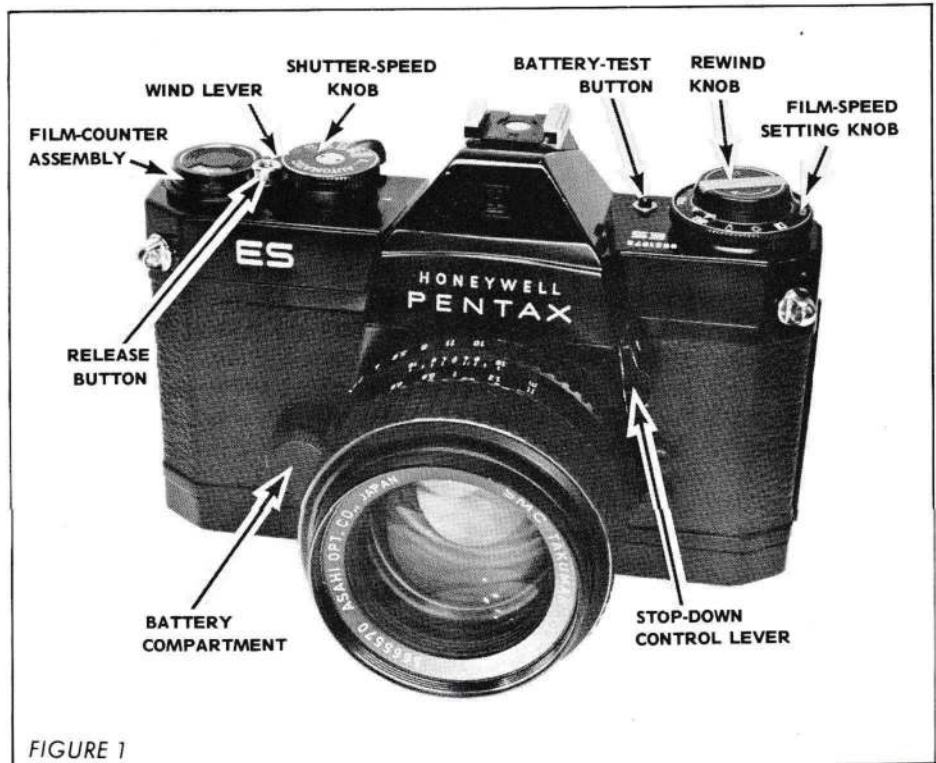

into consideration and programs the shutter speed automatically.

What's "ES" Stand For?

There's some question as to whether the "ES" in Pentax ES stands for "Electronic Shutter" or for "Electro Spotmatic." We've heard both. And both terms seem to apply equally well.

"Electro Spotmatic" is particularly descriptive. Mechanically, the Pentax ES is nearly a mirror image of the conventional Spotmatic. Pentax engineers have cleverly added a highly refined exposure-control system to the faithful design.

Even with the electronic brain, the Pentax ES is only slightly larger than the mechanical Spotmatic — around three ounces heavier and 1/4 inch higher. Most of the electronic system sits neatly packaged on a single circuit board at the bottom of the

camera. Fig. 2 shows the circuit board after removing the camera's bottom plate.

The prototype ES packed some 30 separate components into the base of the camera. But, as you can see in Fig. 2, Honeywell's version replaces the separate components with four IC's (integrated circuits).

IC's definitely have their advantages — more compact, more durable, and better protected from such solid-state enemies as dirt, light, and temperature. But IC's give cold chills to many technicians. Without a schematic, there's no way of knowing exactly what's inside those mysterious "black boxes." Not that a schematic of IC innards would be that much help. Service-wise, about all you can do is check the input and the output to see if the IC is working.

Removing the complete circuit board is as easy as unplugging a lamp (almost). There're no wires to

PENTAX ES

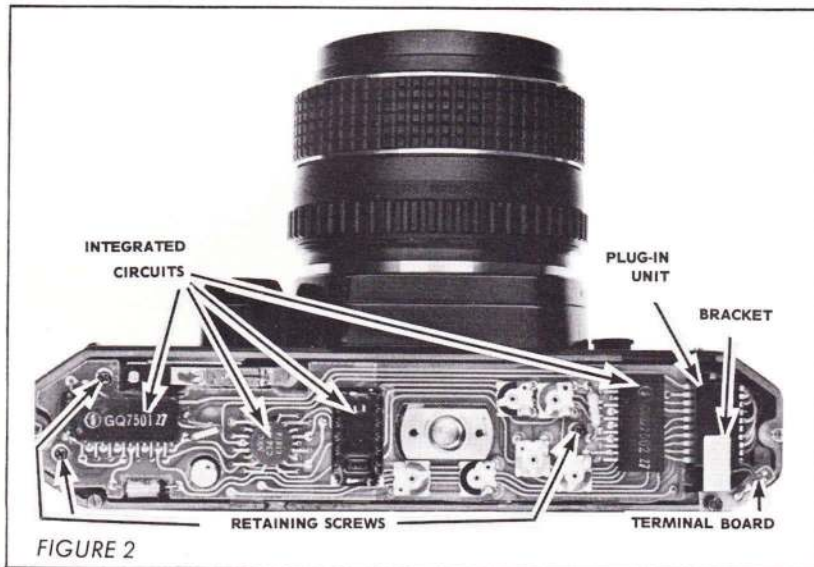

FIGURE 2

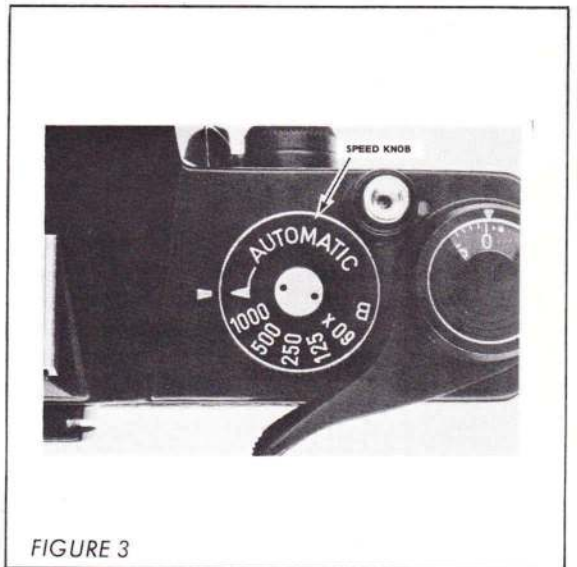

FIGURE 3

disconnect and only four screws to remove.

To remove the circuit board, take out the three cross-point screws, Fig. 2. Also, remove the screw which secures the small terminal board and the bracket holding the plug-in unit. You can now detach — unplug — the circuit board from the plug-in unit.

Features of The Pentax ES

As we mentioned, the mechanical portion of the Pentax ES seemed to jump right out of a Spotmatic blueprint. Which makes sense. Why tamper with a proven design? Especially when that design lends itself so well to electronic control.

The method Pentax engineers used to adapt the Spotmatic shutter for electronic control is especially impressive. Using the same double-roller focal-plane shutter, they've simply added a second latch to the closing curtain — a latch controlled by the electronic brain.

Consider the typical system of electronic-exposure control. In a leaf-type shutter, the shutter blades open mechanically. But an energized electromagnet prevents the blades

from closing until the electronic-control circuit decides that enough light has reached the film.

With a focal-plane shutter, the opening curtain is released mechanically. The closing-curtain latch then holds back the closing curtain for the length of the exposure. All the while, a timing capacitor is charging to a specified voltage — a voltage which will eventually shut off the electromagnet.

Typically, the armature of the electromagnet serves to release the closing-curtain latch. As soon as the timing capacitor reaches a specified charge, it signals the switching circuit to shut off the electromagnet. The electromagnet, now deprived of current, releases its magnetic hold on the armature. And the spring-loaded armature kicks the closing-curtain latch out of engagement to free the closing curtain.

The Pentax ES uses a slight variation. There're two closing-curtain latches, one of which we can call the AUTO LATCH. As long as the electromagnet is energized, it holds the armature — and the armature holds the auto latch engaged with the

closing-curtain wind gear. Once the electromagnet releases its hold on the armature, the closing-curtain wind gear simply pushes aside the auto latch.

If the ES functioned solely as an electronic camera, the one closing-curtain latch would be sufficient. But the ES retains enough Spotmatic features to allow mechanical control as well.

Setting the speed knob, Fig. 3, to "AUTOMATIC" switches in the electronic circuitry. Here, the camera selects the shutter speed electronically, from 1/1000 second to 8 full seconds. Selecting one of the calibrated shutter speeds — 1/60 second to 1/1000 second — opens the switch that feeds the electronic circuitry.

On the manually set shutter speeds, the shutter action is strictly mechanical. That's pretty handy should the battery lose its stuff during an important photographic assignment — you can still use the camera. Now, the conventional closing-curtain latch holds the closing-curtain wind gear for the length of the exposure. The opening curtain kicks

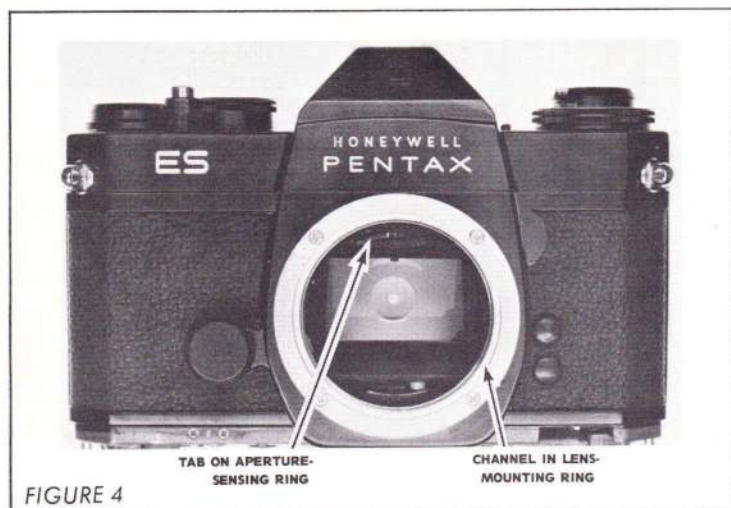

FIGURE 4

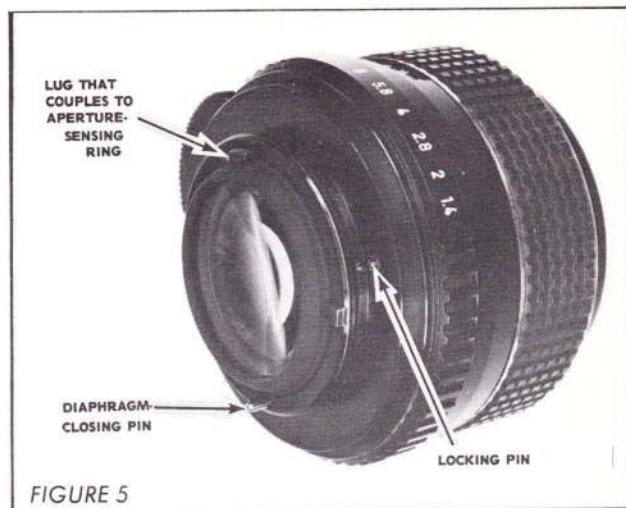

FIGURE 5

the closing-curtain latch out of engagement in typical Pentax fashion.

Power for the ES comes from a 6-volt silver-oxide battery. We're particularly fond of the battery compartment's position in the ES — on the front plate, right next to the lens, Fig. 1. Most cameras house the battery under the top or bottom cover. So, once you've removed the top or bottom cover to make tests and adjustments, you have to power the camera with a separate DC power supply.

The electromagnet sits right behind the battery compartment. In the Spotmatic, this space houses the delayed-action mechanism — the self-timer is the one Spotmatic feature missing in the ES. With the battery compartment and the electromagnet, there just wasn't enough space left for a delayed action.

Full-Aperture Metering In The ES

Lenses for the Spotmatic and the ES are interchangeable. But there is a difference — whereas the Spotmatic takes its exposure reading at stopped-down aperture, the ES meters the light at full aperture. The bonus is that you get a brighter focusing-screen image.

The ES lens couples mechanically to a variable resistor inside the lens-mounting ring. A lug on the back of the lens engages a tab on the spring-loaded APERTURE-SENSING RING shown in Fig. 4. Changing the lens aperture moves the aperture-sensing ring to vary the resistance in the exposure-control circuit.

You can identify the ES lens by the locking pin shown in Fig. 5. With the lens removed from the camera, it's

impossible to switch the auto/manual lever on the lens to the "manual" position — the locking pin latches the auto/manual lever at the "auto" setting. To switch the lens to "manual," you'll have to depress the locking pin.

If you install the ES lens on a conventional camera, the locking pin comes against the lens-mounting ring. So the lens-mounting ring depresses the locking pin and frees the auto/manual lever. Then, you can switch the auto/manual lever to the "manual" position for a depth-of-field preview.

But notice the channel around the lens-mounting ring in the ES, Fig. 4. This channel clears the locking pin to latch the auto/manual lever. Consequently, you cannot stop down the lens by shifting the auto/manual lever to "manual."

Yet you can still take a stopped-down reading with the ES. Suppose, for example, that you're using a conventional lens that doesn't couple to the aperture-sensing ring. Or perhaps you're using an extension tube or bellows to separate the lens from the camera body.

In such cases, push up the stop-down control lever, Fig. 1. The stop-down control lever closes the lens diaphragm to the selected aperture. Simultaneously, the stop-down control lever throws a switch to override the aperture-sensing resistor in the lens-mounting ring. So you can use the stop-down control lever for stopped-down metering or for a depth-of-field preview.

The lens design reflects the factory's consideration for the photographer who already owns an array of Takumar lenses and wishes to move up to the ES. He can still use

his lenses with the ES body. Only two Takumar lenses won't couple properly: the Super-Takumar 50mm f/1.4 and the Super-Takumar 55mm f/1.8 (the one with the "1.8" calibration at the left-hand end of the diaphragm-control-ring scale, seen from the top).

There's even a built-in safety provision should you forget to push up the stop-down control lever. If the lens isn't coupled to the aperture-sensing ring — and if the stop-down control lever is down, in the full-open-metering position — the shutter remains open. A mistake costs you a frame of film. But at least you don't continue to shoot pictures which are improperly exposed.

You can see what happens by operating the camera at the "AUTOMATIC" setting with the lens removed. Removing the lens allows the aperture-sensing ring to travel as far as it can go in a counterclockwise direction, Fig. 4. The result is to open the aperture-sensing resistor — infinite resistance — so the timing capacitor cannot accept a charge.

Consequently — if the stop-down control lever is in the "down" position — the shutter cannot close. When you depress the release button, the shutter opens in the normal manner. But, since the timing capacitor doesn't charge, the closing curtain never gets the release signal.

To release the closing curtain, you can shift the stop-down control lever to the "up" position — that overrides the aperture-sensing resistor. Or you can turn the speed knob to one of the mechanically set shutter speeds. Also, manually turning the aperture-sensing ring in a clockwise direction allows the timing capacitor to charge and release the closing curtain.

Basic Operation Of The Memory Circuit

Although Pentax pioneered the memory circuit, other cameras quickly followed suit with similar circuitry. Recently introduced contenders include the Minolta XM, the Yashica Electro AX, and the Nikkormat EL.

The memory-circuit cameras all hover around the \$600 price category. So none of the cameras really promises to make other automatic systems obsolete — at least for awhile. But the memory circuit nonetheless indicates the going thing in today's camera design.

Fig. 6 is a block diagram of the basic operation. In the ES, pushing the release button part way supplies current to the light-measuring circuit. The memory capacitor then begins to accumulate a charge according to the light intensity.

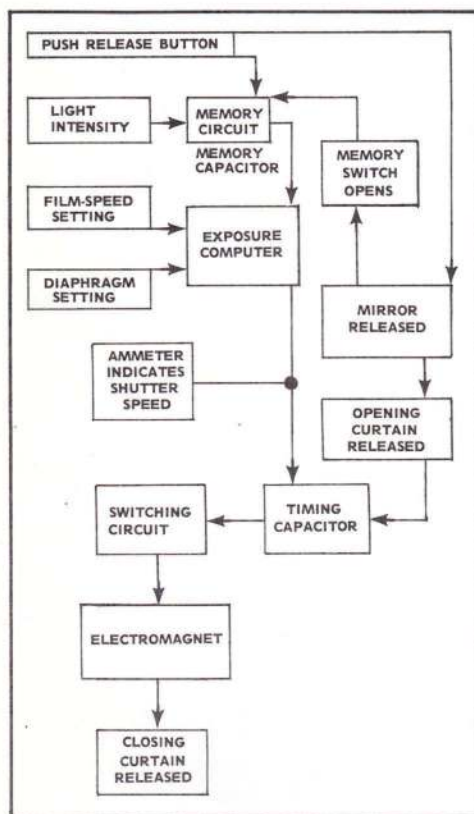

FIGURE 6

Pushing the release button a little further triggers the mirror. The mirror then starts its climb to the taking position and opens the memory switch. Now, the memory capacitor memorizes the light intensity — information it received from the CdS cells before the mirror blocked off the light.

When the mirror reaches the taking position, it releases the opening curtain. And the opening curtain opens the timing-capacitor switch. Now, the timing capacitor begins to charge according to the information it receives from the light-measuring circuit.

If the light intensity were the only exposure consideration, the timing capacitor could simply charge until it reached the voltage level of the memory capacitor. But there are other factors — namely the diaphragm setting and the film-speed setting. So these settings, along with the voltage memorized by the memory capacitor, are fed to a "computer" — together, they decide the rate of current flow that charges the timing capacitor.

The current flow to the timing capacitor is the reciprocal of the exposure. In other words, a larger f/stop, higher film speed, or higher light intensity increases the charging current. And the greater the charging current, the faster the timing capacitor charges to the reference voltage which shuts off the electromagnet. So the end result of increasing the charging current is a faster shutter speed.

Once the timing capacitor reaches the predetermined charge, it notifies a transistor switching system. The transistor switching system then shuts off the current flowing through the electromagnet. And the electromagnet, now deprived of current, releases its armature to free the closing curtain.

Comparison — ES vs. Spotmatic

The first look inside an ES may cause temporary panic — there's quite a maze of wires running hither and yon throughout the camera. The wiring pictorial, Fig. 7*, gives you an idea of the complexity (the color codes marked on the pictorial are from the camera we disassembled for evaluation — we can't guarantee they'll be the same in other cameras).

But if you'll look past the wiring network, you'll quickly recognize an old friend — the Pentax Spotmatic. That's kind of a comforting feeling. After all, Pentax cameras have long enjoyed the reputation of being the most pleasant of all SLR's to service.

The family resemblance is apparent after removing the top cover, Fig. 8. Notice that even the galvanometer sits in the same position. But the galvanometer in the ES has a new role to play.

In the Spotmatic, the galvanometer couples electrically to the shutter controls. Changing either the shutter speed or the film speed varies the setting of a potentiometer in the exposure-meter circuit. Changing either the diaphragm opening or the light intensity affects the resistance of the CdS photocells, also in the exposure-meter circuit.

The Spotmatic metering action is semiautomatic. That is, the photographer sets the camera variables by aligning the exposure-

(continued page 18)

*See pages 16-17 for Figure 7.

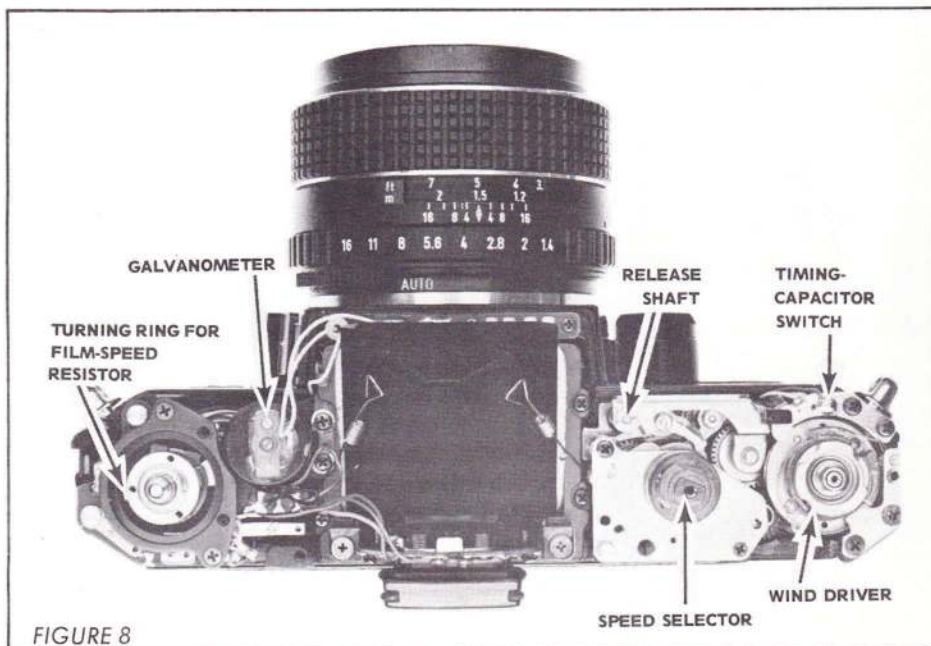
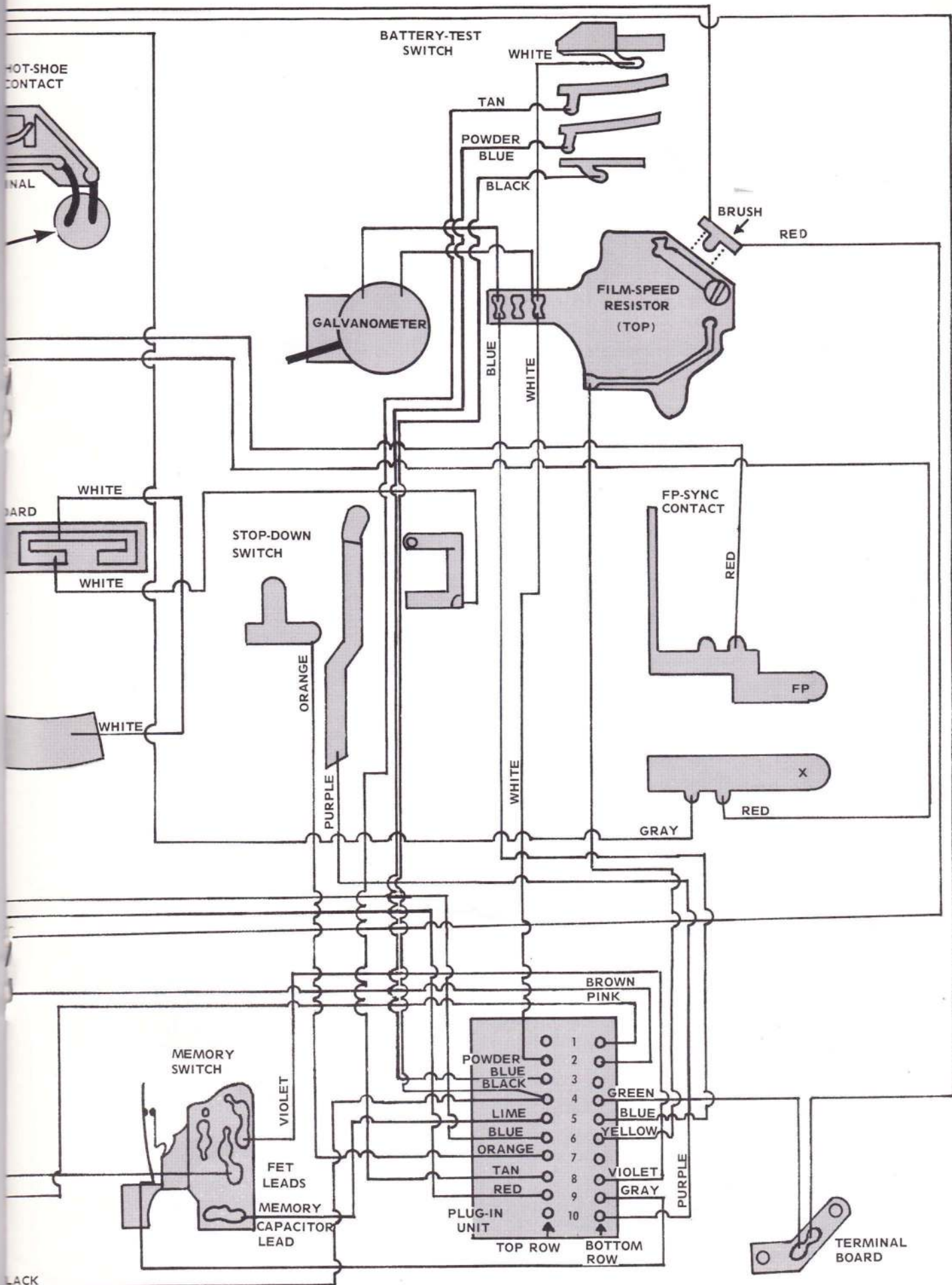

FIGURE 8



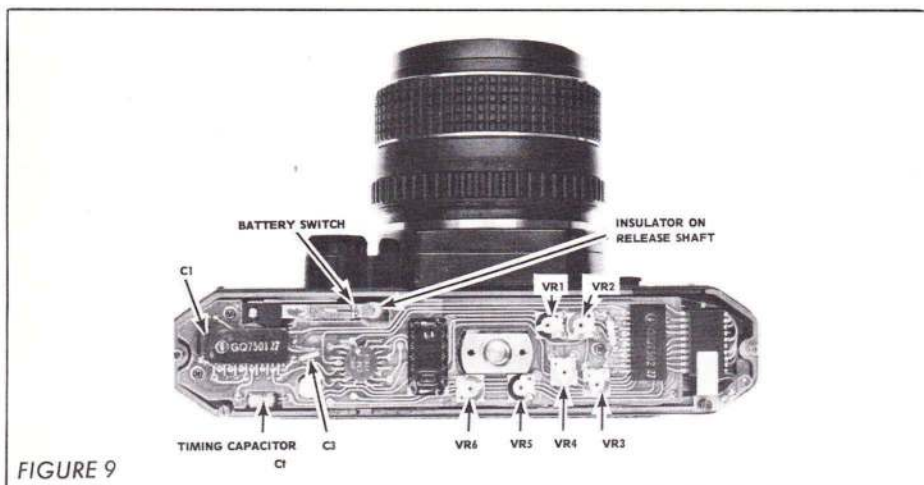

FIGURE 9

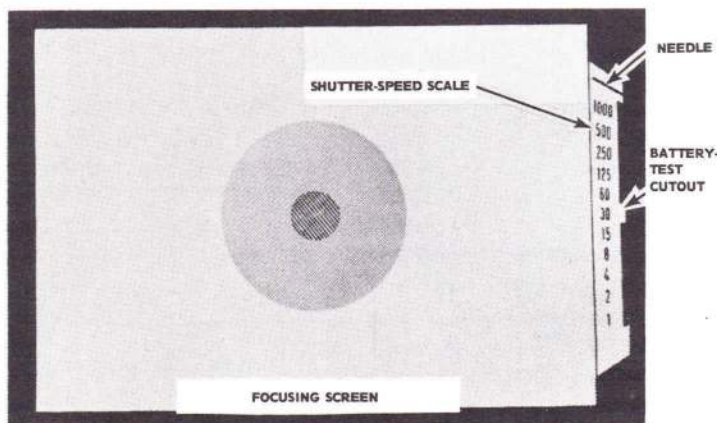

FIGURE 10

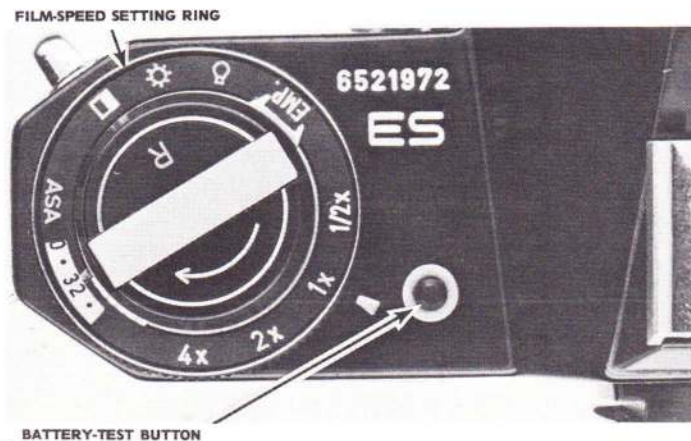

FIGURE 11

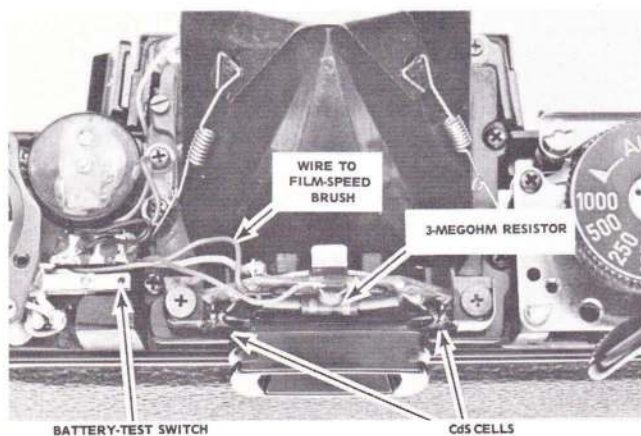

FIGURE 12

meter needle with an indicator. But the ES is fully automatic — the camera selects the shutter speed according to the light conditions, the diaphragm setting, and the film speed.

So the galvanometer in the ES serves to notify the photographer as to what shutter speed the camera is going to deliver automatically. In the block diagram, Fig. 6, you can see that the galvanometer takes all the variables into consideration to provide a time indication.

The galvanometer goes into action as you start depressing the release button. An insulator at the end of the release shaft closes the battery switch at the bottom of the camera, Fig. 9. Among other duties, the battery switch channels current to the galvanometer; the amount of current depends on the diaphragm opening, the film-speed setting, and the light intensity. So the galvanometer needle deflects along a shutter-speed scale calibrated on the focusing screen, Fig. 10.

That can be a pretty handy feature. Not too many automatic cameras tell you in advance what shutter speed to expect. Even though the exposure time is automatically programmed, you can nonetheless select the shutter speed you want — just vary the diaphragm opening.

Yet retaining the delicate galvanometer does seem to defeat one of the major advantages of the electronically controlled shutter: the increased ruggedness. The extra ruggedness of the electronic shutter is the result, after all, of eliminating the fragile galvanometer. Fortunately, a damaged galvanometer in the ES wouldn't be a complete disaster — you could still use the camera.

The galvanometer serves one other function in the ES — a battery-test indicator. Pushing the battery-test button on the top cover, Fig. 11, actuates the battery-test switch, Fig. 12. If the battery is good, the galvanometer needle moves to the center of a cutout adjacent to the "30" calibration, Fig. 10.

The adjustment for the battery-test circuit is the variable resistor VR3 on the main circuit board, Fig. 9. Variable resistors VR1 and VR4 also affect the needle movement during the battery test — use these resistors to adjust the exposure-time indication when you depress the release button. VR3 affects only the reading obtained by depressing the battery-test button.

To the left of the galvanometer, you can see the circuitry that compensates for different film speeds. The film-speed resistor mounts to the underside of the circuit board at the rewind side of the camera, Fig. 8.

A notch on the underside of the film-speed setting ring, Fig. 11, straddles the upward-projecting tab shown in Fig. 8 — the tab is part of the turning ring for the film-speed resistor. Moving the turning ring changes the position of a resistor ring with respect to a fixed brush.

The film-speed resistor also provides an automatic override for the exposure-control system. To change the film speed, lift and rotate the film-speed setting ring. But just rotating the film-speed setting ring (without lifting) allows you to dial in an exposure-compensation factor.

For normal lighting situations, leave the film-speed setting ring at the "1x" position, Fig. 11. Then, say you have a strongly backlit subject and need a slower shutter speed — just turn the film-speed setting ring clockwise until the "2x" calibration aligns with the index. "2x" means twice the exposure, the next-slower shutter speed. "4x" provides four times the normal exposure — for example, 1/30 second rather than 1/125 second.

If you want a faster-than-normal speed, use the "1/2x" setting. That gives you 1/2 the normal exposure, the next-faster shutter speed.

Notice that a red wire goes from the film-speed resistor to a circuit board behind the pentaprism, Fig. 12. The red wire attaches to the brush of the film-speed resistor. "Red" in the ES indicates the positive battery voltage. So the red wire in Fig. 12 supplies 6 volts to the 3-megohm resistor just above the eyepiece.

The two CdS cells, in series with one another, connect in parallel to the 3-megohm resistor. Fig. 12 points out the two CdS cells, one on either side of the eyepiece. The light-measuring philosophy is another Spotmatic carryover — that is, the two CdS cells read the light over the complete focusing screen for an averaging system.

Going now to the wind side of the camera, Fig. 8, you can again spot the mechanical similarities. At first glance, the wind-side mechanism looks nearly identical to the Spotmatic. One colorful difference, though, is that there're two wires —

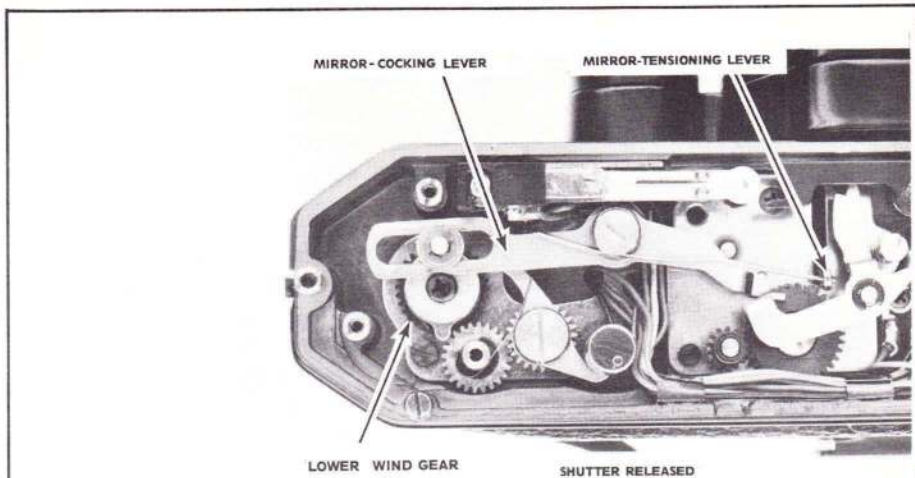

FIGURE 13

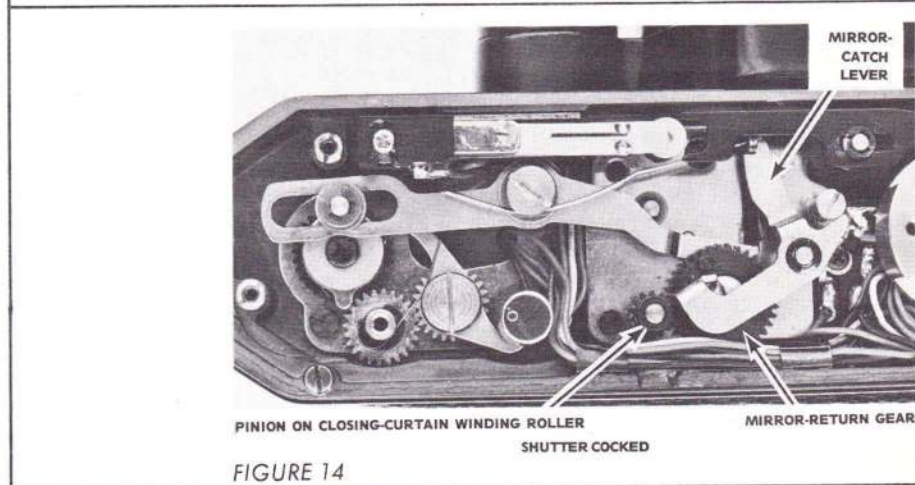

FIGURE 14

one red and one pink — attached to the contact points by the wind lever. These wires go to the timing-capacitor switch; that's the switch that controls the point at which the timing capacitor begins accepting a charge. We'll discuss the operation of the timing-capacitor switch after removing the speed-control bridge.

First, however, let's take a look at the mechanical similarities at the bottom of the camera. After removing the bottom plate, Fig. 2, the ES doesn't look much like the Spotmatic — or any other camera. But when you take out the main circuit board, you can see that the mirror-cocking mechanism remains virtually unchanged, Fig. 13.

When you advance the wind lever, the lower wind gear rotates in a clockwise direction. The rotation of the lower wind gear drives the slotted end of the mirror-cocking lever toward the back of the camera — that's because the slotted end of the mirror-cocking lever slips over a pin on the lower wind gear.

So the right-hand end of the mirror-cocking lever drives the mirror-

tensioning lever toward the front of the camera. And the mirror-tensioning lever tensions the mirror-lifting spring (the spring which will later lift the mirror to the taking position). In the shutter-cocked position, the mirror-catch lever latches the mirror-tensioning lever, Fig. 14.

Pushing the release button triggers the mirror. Now, the mirror rises to the taking position and releases the opening curtain. On the "AUTOMATIC" setting, the closing curtain remains latched until the electromagnet gets the release signal.

The mirror-catch lever continues holding the mirror-tensioning lever until the closing curtain crosses the focal-plane aperture. Naturally, the mirror must remain in the taking position during the exposure — so, in typical focal-plane fashion, it's the closing curtain that brings the mirror back to the viewing position.

Notice the pinion attached to the bottom of the closing-curtain winding roller, Fig. 14. The pinion drives the mirror-return gear. Consequently, the mirror-return gear always rotates as

the closing curtain crosses the focal-plane aperture — both during the cocking cycle and during the release cycle.

During the release cycle, the mirror-return gear rotates clockwise. Finally — when the closing curtain nears the end of the focal-plane aperture — the stud on the mirror-return gear strikes the mirror-catch lever. Disengaging the mirror-catch lever frees the mirror-tensioning lever. Now, the mirror returns to the viewing position.

within the memory-switch assembly, sealed in epoxy. One lead of the memory capacitor hooks to the fixed blade of the memory switch. The other end extends through the circuit board where it joins the green wire coming from the plug-in unit, Fig. 7.

Fig. 16 shows the arrangement of the components within the memory-switch assembly. Notice that the lead of the memory capacitor — the same lead that hooks to the switch — couples to the gate of a FET (field-

effect transistor). The FET, also sealed within the memory-switch assembly, provides a large gate-source impedance to prevent signal leakage from the memory capacitor.

Pushing the release button all the way down releases the mirror. And the mirror-operating parts release the memory-switch control lever, Fig. 15. The spring-loaded memory-switch control lever then fires from right to left in Fig. 15.

All you can presently see of the memory-switch control lever is the insulated stud shown in Fig. 15. The memory-switch control lever mounts to the bottom of the mirror cage. The insulated stud then passes through a hole in the camera body to operate the memory switch.

As the memory-switch control lever moves from right to left, the insulated stud opens the memory switch, Fig. 17. So the memory's brain stops its calculations at the moment the mirror releases. The last exposure data seen by the photocells is now on record.

NOTE: We're simulating the action in Fig. 17. With the circuit board removed, the shutter won't stay open. Without the circuit board — or without the battery — the ES delivers 1/1000 second at the "AUTOMATIC" setting.

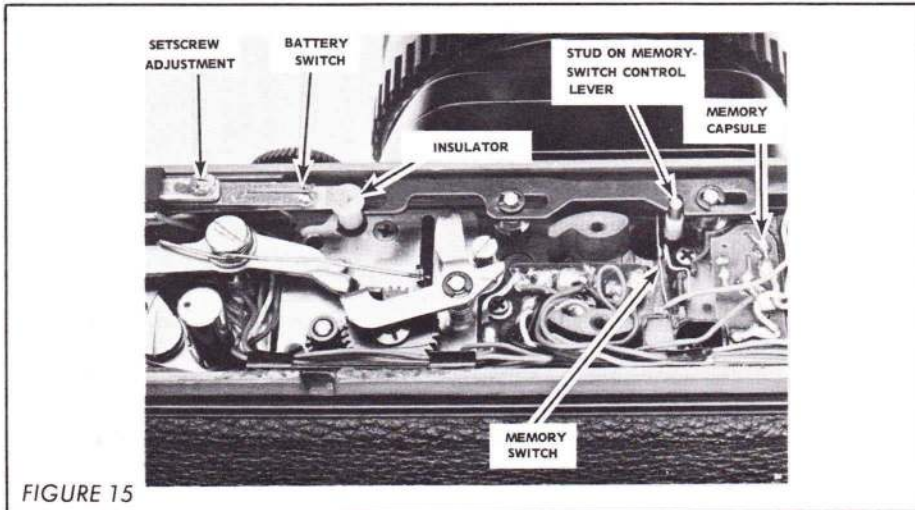

FIGURE 15

Memory And Battery Switch Operation

If you already know the Spotmatic camera, all that description is old stuff. But there are a couple of new twists at the bottom of the ES. In Fig. 15, we've removed the tripod socket to show the memory switch.

The memory switch is normally closed. So the memory circuit is ready for action — to take notes as dictated by the CdS cells.

Remember, depressing the release button brings the insulator, Fig. 15, against the lower blade of the battery switch. The battery switch now routes current to the galvanometer, the electromagnet, and the memory circuit. And the memory circuit records the resistance of the photocells by charging the memory capacitor.

You can't see the memory capacitor — in fact, you never will unless you destroy the memory-switch assembly (which we did using a replacement component just to see what was inside). The memory capacitor sits

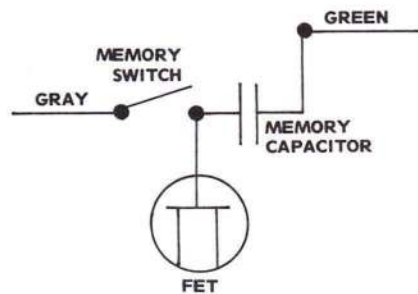

FIGURE 16

You can check the action of the memory switch by hooking a voltmeter across the timing capacitor Ct, Fig. 9. With the shutter in the released position, depress the release button to close the battery switch. Now, vary the shutter controls and the light intensity while observing the charge on Ct.

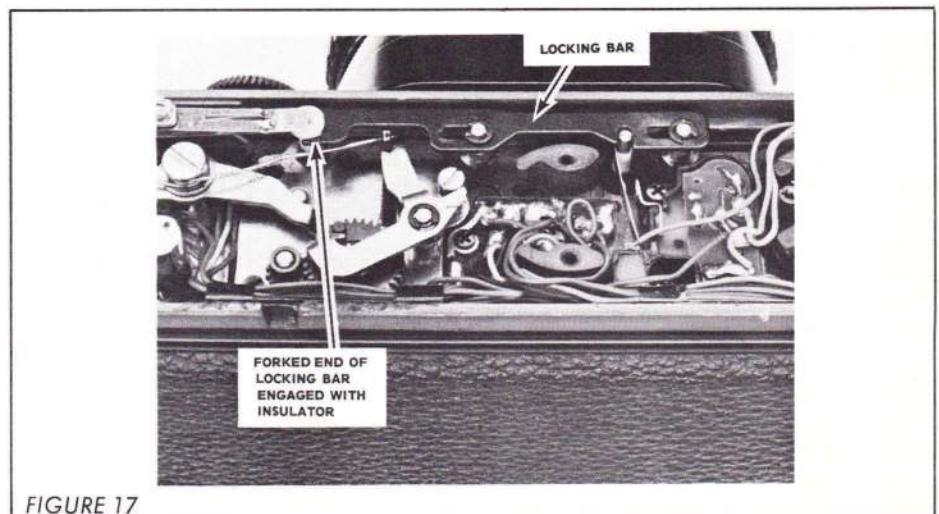

FIGURE 17

The larger the *f*/stop, the greater the charge on Ct. Setting a faster film speed also increases the charge on Ct. And, as follows, increasing the light intensity increases the charge.

Suppose, then, that changing the light intensity has no effect on the charge. The problem could be that the memory switch isn't closing properly — or isn't making good contact. A faulty memory switch could also cause erratic exposure times.

Next, hold the memory switch open and make the same voltage check. This time, there should be no voltage change across Ct as you vary the light intensity.

With the shutter cocked, the timing capacitor cannot accept a charge. The reason is that the timing-capacitor switch closes as you cock the shutter. Releasing the shutter opens the timing-capacitor switch, allowing the timing capacitor to charge. So the timing capacitor charges to the voltage you noted when the shutter was in the released position.

But the closing curtain may release before the timing capacitor reaches its full charge. As soon as the timing capacitor reaches the reference voltage stored across C1, Fig. 9, the transistor-switching system shuts off the current flowing through the electromagnet. The shutter variables and the memory circuit just determine how long it takes for Ct to reach the reference charge.

The other capacitor on the main circuit board — C3 in Fig. 9 — hooks in parallel with the coils of the electromagnet. C3 appears to be a shock absorber. That is, it handles the counter electromotive force induced in the coils when the transistor-switching system shuts off the current.

Adjusting the exposure time does require an EE testing system such as the Comparasystem. Naturally, you have to know what shutter speed the shutter should be delivering in order to make adjustments.

You'll then find that variable resistor VR2, Fig. 9, controls the voltage across the timing capacitor when the stop-down control lever is down (the full-open-metering position). And variable resistor VR6 controls the voltage across Ct when the stop-down control lever is up (the stopped-down-reading position). So you can use VR2 to adjust the exposure time in the full-open-metering position; and use VR6 to adjust the exposure time in the

stopped-down-metering position.

Fig. 17 illustrates another function of the memory-switch control lever. Notice the locking bar positioned above the memory switch — the insulated stud on the memory-switch control lever passes through a cutout in the locking bar. As the memory-switch control lever moves from right to left, it carries the locking bar in the same direction.

The forked end of the locking bar then moves underneath a lip on the release-shaft insulator (the insulator that closes the battery switch). As long as the shutter is open — and the mirror is in the taking position — the locking bar holds the insulator engaged with the battery switch.

The reason? Naturally, you have to maintain battery current for the full duration of the exposure. Without the locking bar, the battery switch could open as soon as you let up the release button. That would cut off the current to the electromagnet, ending the exposure.

But the locking bar keeps the battery switch closed — even after you let up the release button. The insulator, you see, isn't firmly attached to the release shaft; rather, it just fits loosely over the end of the shaft. So the release shaft can return to its rest position while the insulator continues to hold the battery switch in the switch-closed position.

When the mirror returns to the viewing position, the mirror-cage parts drive the memory-switch control lever from left to right. The memory switch then closes, in

preparation for the next exposure. And the battery switch pushes the insulator toward the top of the camera — against the release shaft.

Notice that the battery switch features a typical Pentax-type adjustment — a setscrew with a locking collar, sealed with red lacquer. After loosening the locking collar, you can turn the setscrew in or out. The result is to change the space gap between the blades of the battery switch.

The adjustment decides how far you have to depress the release button before closing the battery switch. In our test camera, the battery switch closed just as the lip of the insulator moved above the forked end of the locking bar. If the battery switch made later than that, it would open as soon as you let up on the release button.

Incidentally, we didn't describe the disassembly technique for the top cover. But the procedure is nearly the same as in the Spotmatic. There are no timing points to scribe, no wires to disconnect.

We might mention, however, the retaining nut that holds the counter plate, Fig. 18. In the Spotmatic, this nut may have a left-hand thread — most have right-hand threads. In our sample ES, the nut had a left-hand thread.

There's also a reassembly precaution worth noting: make sure the fork on the underside of the film-speed setting ring straddles the tab on the turning ring for the film-speed resistor. Then, the pin on the

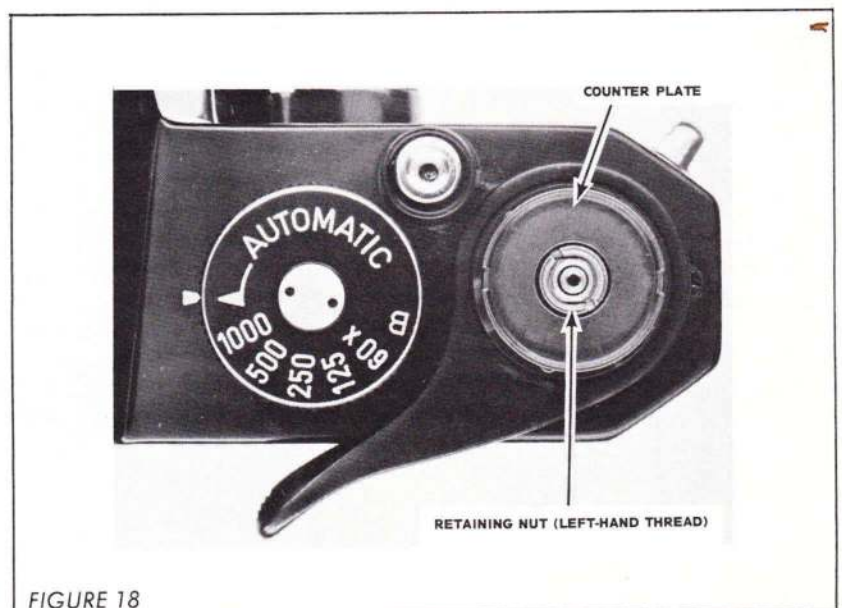

FIGURE 18

underside of the film-speed indicator assembly must pass through a hole in the film-speed setting ring. Fig. 19 shows the three screws that hold the film-speed indicator assembly.

Removing And Adjusting The Front Plate

The view underneath the front leatherette holds a real treat in store for the camera-repair technician, Fig. 20. Each of the front-plate retaining screws passes through the center of a threaded bushing. The five threaded bushings serve as mounting seats for the front plate.

The advantage? In the ES, you can adjust the front plate by simply turning the threaded bushings. That's many times faster and easier — not to mention more accurate — than adjusting the front plate with shims, the normal procedure.

You'll adjust the front plate for both the proper lens-mounting distance (45.46mm) and for parallelism. To adjust the lens-mounting distance, turn the threaded bushings equally — that moves the entire front plate in or out.

Since our test camera checked O.K. in the parallelism department, we scribed the positions of the threaded bushings in Fig. 20. But it's a good idea to check the parallelism of any camera before you remove the front plate — an extreme parallelism error is a good indication that the camera has been dropped.

You can check parallelism with a dial gauge or with a depth micrometer. But the easiest way — as well as the fastest and most accurate — is with an Auto-Collimator. So we'll describe the front-plate adjustment technique using the National Camera Auto-Collimator.

Besides the Auto-Collimator, you'll need the camera-alignment fixture shown in Fig. 21. The camera-alignment fixture, available for either 35mm or 70mm film formats, consists of a flat, front-silvered mirror which fits the film-guide rails. There's one adjustable leg to level the fixture, Fig. 22.

The procedure we're using takes advantage of one of the Auto-Collimator's optical traits:

If a mirror is placed so that it is perfectly perpendicular to the optical axis of the Auto-Collimator, the illuminated target appears centered on the reticle, Fig. 23.

SCREWS HOLDING FILM-SPEED INDICATOR ASSEMBLY

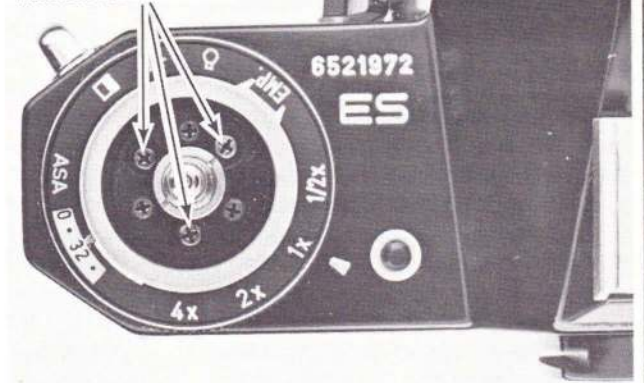

FIGURE 19

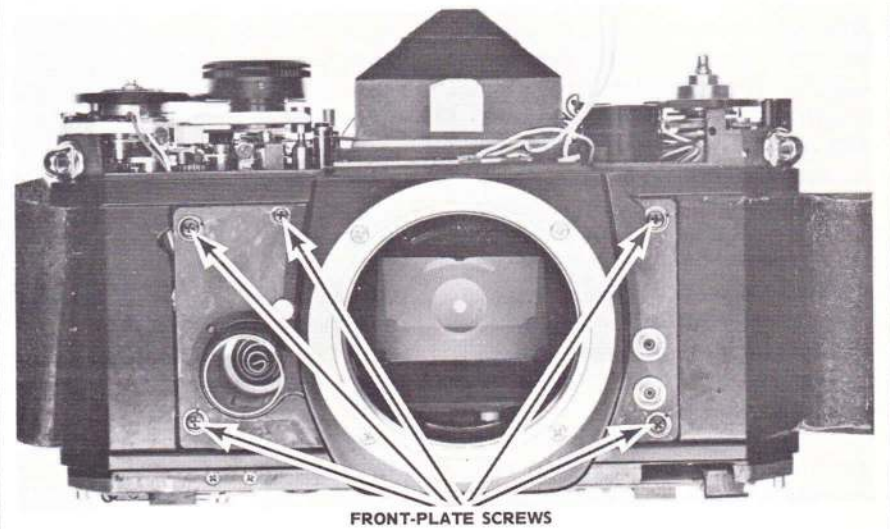

FIGURE 20

MIRROR SURFACE



FIGURE 21

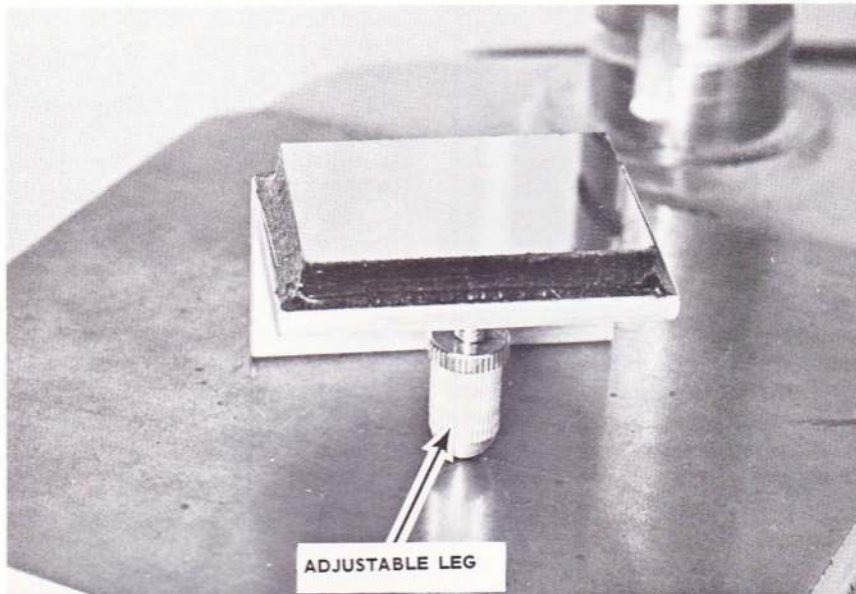

FIGURE 22

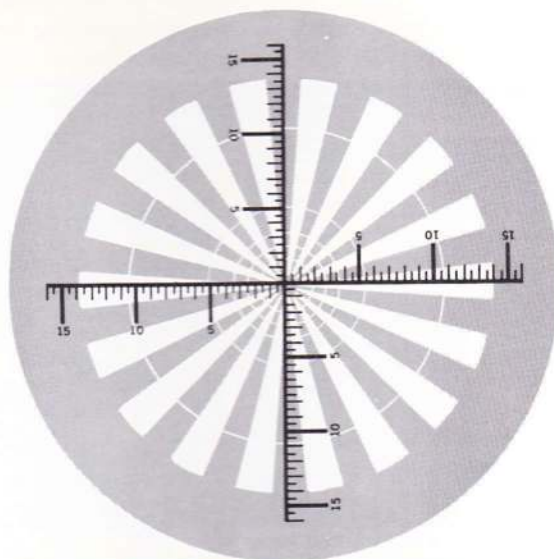

FIGURE 23

TARGET CENTERED ON RETICLE

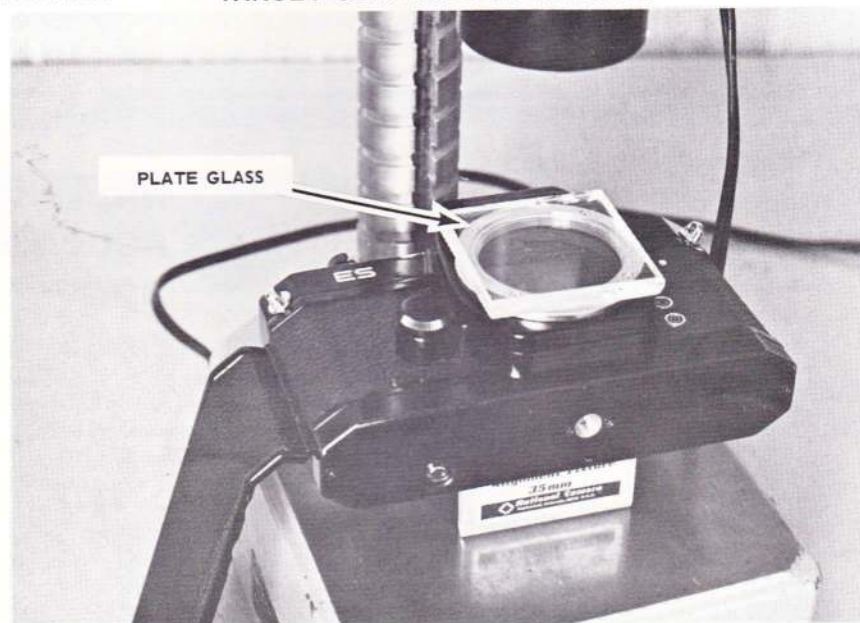

FIGURE 24

In other words, Fig. 23 shows the picture you'll see looking through the eyepiece of the Auto-Collimator (providing the mirror is perpendicular to the optical axis). But if the mirror is tilted, the illuminated target appears off-center — perhaps completely out of the picture.

Place the camera-alignment fixture on the Auto-Collimator, Fig. 21. Now, examine the position of the illuminated target with respect to the reticle.

For the parallelism test, it's not essential that the target is perfectly centered on the reticle. However, you can center the target if you wish. To move the target up or down, adjust the leg on the camera-alignment fixture; to move the target from side to side, swing the head of the Auto-Collimator.

Next, remove the taking lens of the camera. Carefully place the camera on the camera-alignment fixture — only the film-guide rails must touch the mirror surface.

As shown in Fig. 24, set a piece of plate glass on the lens-mounting ring of the camera. The plate glass comes supplied with the camera-alignment fixture.

You can now tell if the lens-mounting ring is parallel to the film-guide rails. If it is, the target seen on the plate glass should be in the same position as that seen on the camera-alignment fixture. Probably the easiest way to check the two images is to hold open the shutter on "bulb." That allows you to view the two images simultaneously. If the two surfaces are parallel, the two images should be superimposed on one another.

But say the two images don't superimpose. How do you know which side of the front plate requires adjustment? Simply tilt the glass. Suppose, for example, that lifting the right-hand side of the glass superimposes the images. Then, you know that you must raise the right-hand side of the front plate — or lower the left-hand side.

In most 35mm SLR's, such an adjustment requires removing the front plate to add or take out shims. But in the ES, all you have to do is loosen the appropriate front-plate retaining screw. Then, screw in the threaded bushing to raise that corner of the front plate — or screw out the threaded bushing to lower it.

To remove the front plate, you'll have to unsolder the white wire shown

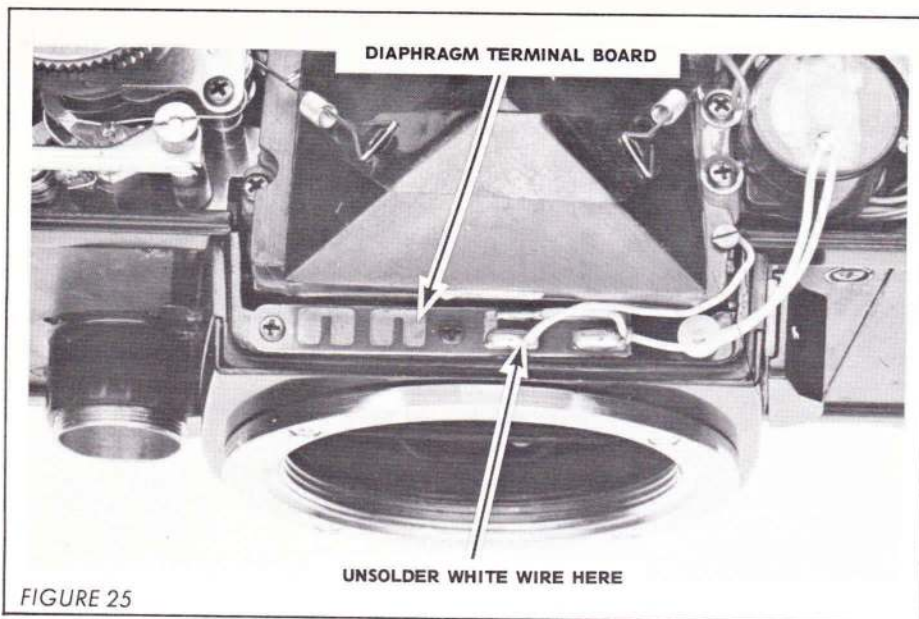

FIGURE 25

in Fig. 25; this is the wire that connects the resistance band behind the lens-mounting ring to a switch inside the camera.

Next, remove the five front-plate retaining screws, Fig. 20. Notice that one of the screws is quite a bit smaller than the other four. Each screw passes through the center of a conical bushing; the five conical bushings serve to clamp the adjusted positions of the threaded bushings.

You can only lift the front plate a slight distance from the camera body — the battery-compartment wires are still hanging on. Unsolder the black (negative) wire from its hooking point at the back of the battery compartment, Fig. 26. And unsolder the red (positive) wire from the ground strip mounted on the front plate, Fig. 27.

(continued in next issue)

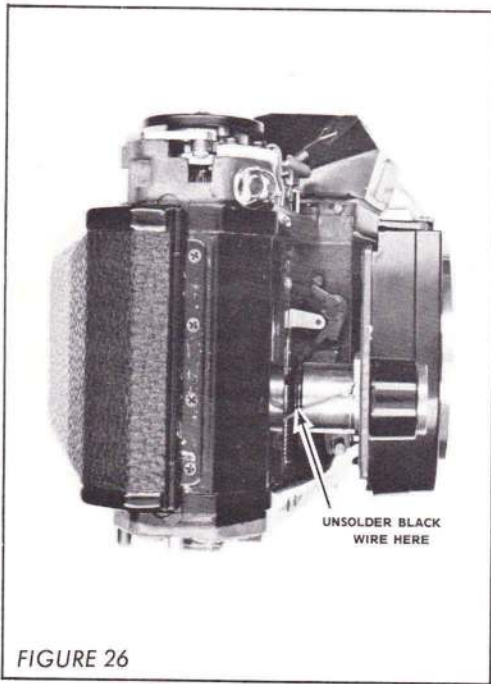

FIGURE 26

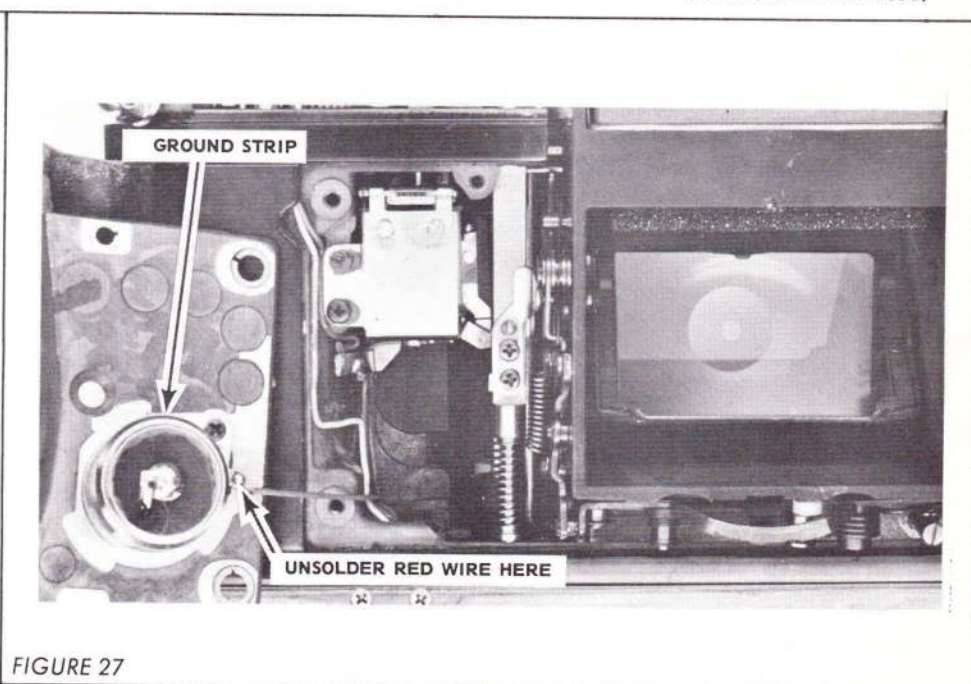







FIGURE 27



	Flat Head	Chrome	Black Nickel
		1.4 x 2.0	1.2 x 2.5
		1.7 x 2.2	1.4 x 1.6
		1.7 x 5.0	1.4 x 2.0
		2.0 x 2.5	1.4 x 3.0
	Round Head		
		2.3 x 3.5	1.7 x 2.2
			1.7 x 4.0
			1.7 x 7.0
			2.0 x 2.5
		Black Nickel	
		1.4 x 1.4	
		1.4 x 2.0	
	Chrome	1.4 x 4.0	1.7 x 6.0
	1.7 x 2.0	1.7 x 1.4	2.0 x 4.5
	1.7 x 3.0	1.7 x 2.0	2.0 x 6.0
	2.3 x 4.5	1.7 x 3.0	2.3 x 5.0

	Setscrews	Chrome	1.4 x 2.0
		1.2 x 2.0	1.4 x 3.0
		1.4 x 1.2	1.7 x 1.8
		1.7 x 2.0	1.7 x 2.5
		Black Nickel	1.7 x 3.0
	1.2 x 1.8	2.0 x 2.0	
	1.4 x 1.6	2.0 x 3.0	

	Fillister Head	Black Nickel	1.7 x 2.0
		1.2 x 1.6	1.7 x 4.0
		1.2 x 2.5	1.7 x 8.0
		1.4 x 1.4	2.0 x 1.6
		1.4 x 2.0	2.0 x 3.0
	1.4 x 3.0	2.0 x 4.0	
	1.4 x 4.0	2.0 x 9.0	
	1.7 x 1.4	2.3 x 9.0	

Steel Balls  **METRIC screws and balls**

1.0 1.2
1.5 1.6
2.0 3.0
5.0

SAVE NOW ON
METRIC SCREWS AND BALLS in packages of 25 at great reduction! Don't lose valuable repair time — have essential sizes on hand. Any five packages of 25 — \$7.50; Individual packages of 25 — \$2.00. Specify size. DO NOT send samples. All sizes in millimeters.
ADDRESS ORDER TO PARTS DEPT. National Camera, 2000 W. Union Ave., Englewood, Colo. 80110.



THE HONEYWELL

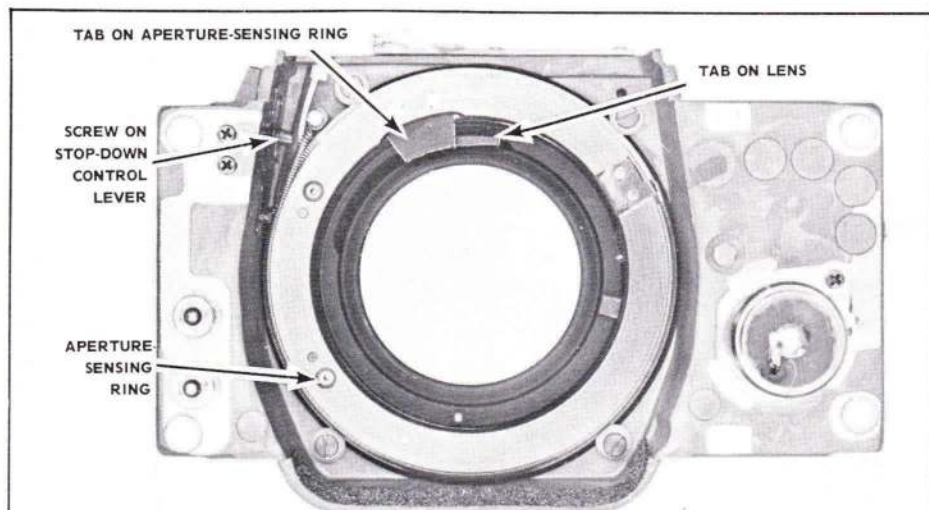

FIGURE 28

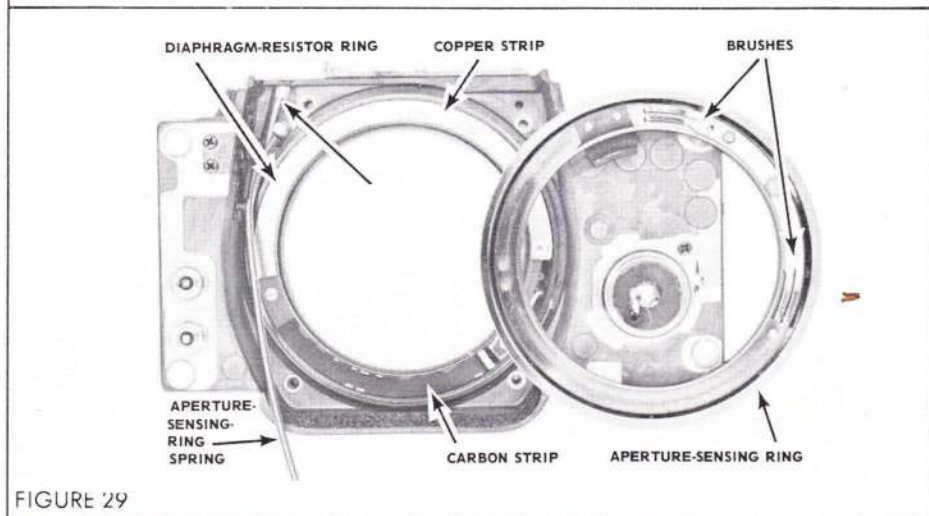

FIGURE 29

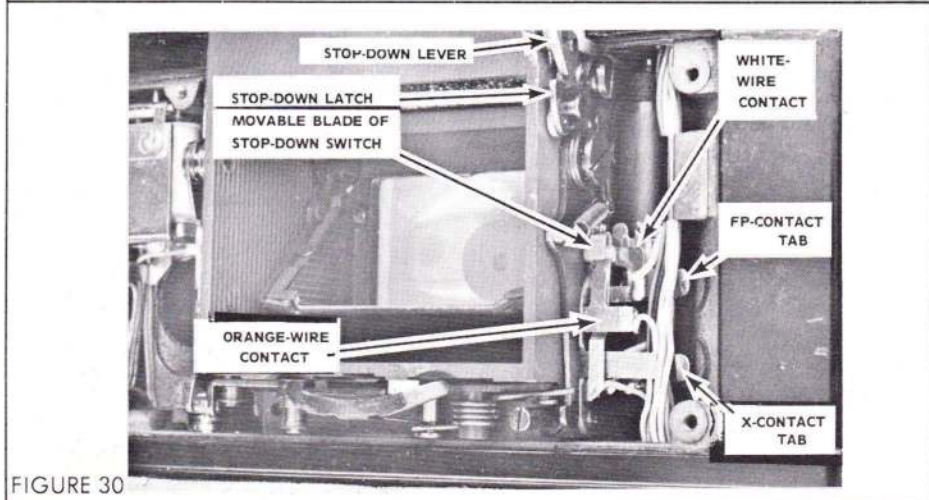

FIGURE 30

Diaphragm Resistor And Stop-Down Switch

Fig. 28 shows the inside of the front-plate assembly with the lens in place. Notice how the tab on the lens connects to the tab on the aperture-sensing ring.

Turning the diaphragm-setting ring (on the lens) moves the aperture-sensing ring — counterclockwise in Fig. 28 if you're setting larger f/stops. And the aperture-sensing ring carries the two brushes, shown in Fig. 29 after disassembly.

The diaphragm-resistor ring, Fig. 29, is grounded to the front plate. But the carbon strip is insulated from the diaphragm-resistor ring. So the brushes on the aperture-sensing ring bridge the electrical gap between the carbon strip and the grounded copper strip of the diaphragm-resistor ring.

The white wire shown in Fig. 29 connects the carbon strip to the diaphragm-terminal board, Fig. 25 — to the same point electrically as the white wire you disconnected. The other end of the wire you disconnected attaches to the stop-down switch, Fig. 30.

In the full-open-reading position of the stop-down switch, the movable blade is against the white-wire contact, Fig. 30. Then, the resistance between the white wire and ground is in the exposure-control system.

Shifting the stop-down control lever to the stopped-down-reading position throws the movable blade toward the front of the camera. That disconnects the white-wire contact and instead connects the orange-wire contact to the circuit. Now, the diaphragm-resistor ring has nothing to say about the length of the exposure. But the stopped-down aperture affects the exposure by controlling the resistance of the CdS cells.

A screw on the stop-down control lever, Fig. 28, engages the upper end of the stop-down lever, Fig. 30. Moving the stop-down control lever up

PENTAX ES

pushes the upper end of the stop-down lever toward the back of the camera.

The lower end of the stop-down lever then pushes the diaphragm-control bar toward the front of the camera. The diaphragm-control bar is the part that engages the pin in the lens, stopping down the diaphragm to the taking aperture.

In the stopped-down-reading position, the stop-down latch, Fig. 30, holds the stop-down lever. Notice the insulated stud on the stop-down lever that passes through a loop in the movable blade of the stop-down switch — this is the stud that moves the movable blade forward to override the diaphragm-sensing resistor.

Pushing down the stop-down control lever disengages the stop-down latch. So the diaphragm opens to the full-aperture position and the stop-down switch connects the diaphragm-sensing resistor to the circuit.

Checking The Electromagnet

At the other side of the mirror cage, Fig. 31, you can see the electromagnet. The pin on the electromagnet's armature reaches through a cutout in the camera body to engage the auto latch. As long as the electromagnet remains energized, the electromagnet holds the armature against the core. In turn, the armature's pin holds the auto latch engaged with the closing-curtain wind gear.

When energized, the electromagnet drops nearly the full 6 volts supplied by the battery. So, if you suspect a defective electromagnet (maybe the shutter won't stay open), you can quickly check the operation with a 6-volt power supply.

Two tabs at the bottom of the electromagnet supply the two coils — a brown wire hooks to the negative

side and a bare (ground) wire hooks to the positive side. While holding the power-supply leads to the two tabs, the shutter should stay open; the shutter should close as soon as you remove one of the leads.

Alternately, you can test the electromagnet with an ohmmeter. Disconnect the brown wire. Then check the resistance between the two tabs of the electromagnet. The coil resistance in our test camera measured 320 ohms.

Fig. 32 provides a better view of the

pin on the electromagnet's armature. Here, you can also see the mirror-release linkage.

When you depress the release shaft, the release actuator pushes the mirror latch out of engagement with the mirror-lifting lever. The mirror-lifting lever then drives the mirror to the taking position. As the mirror reaches the taking position, another lever (not yet visible) drives the opening-curtain striker against the opening-curtain latch. *continued*

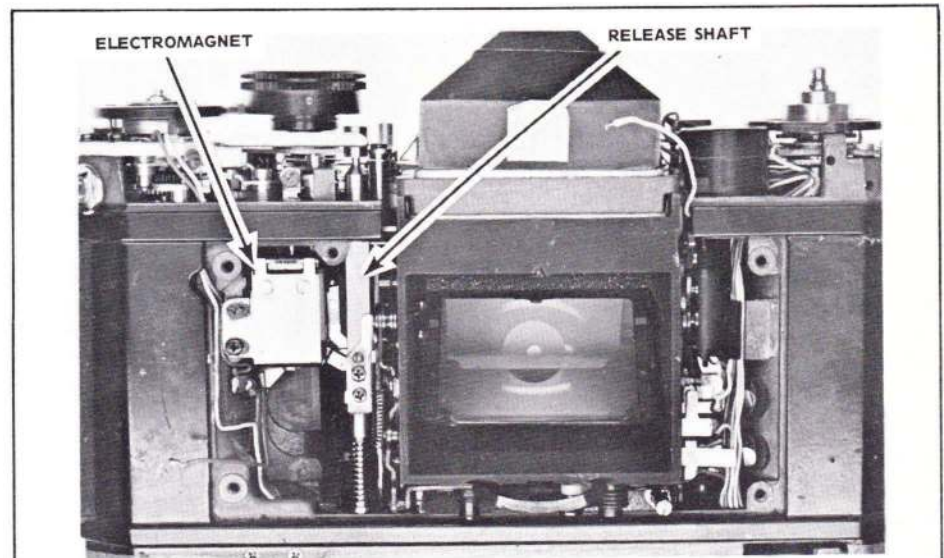

FIGURE 31

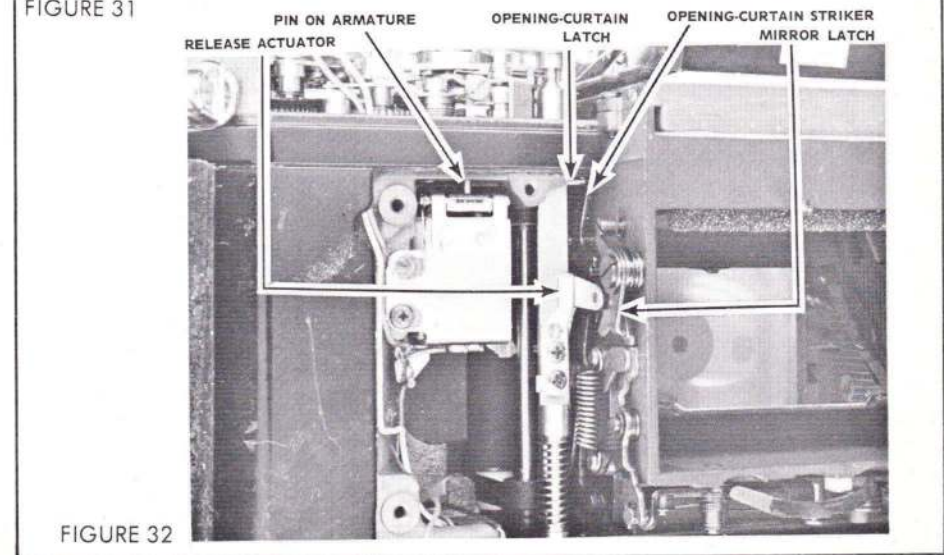

FIGURE 32

Disengaging the opening-curtain latch frees the opening-curtain wind gear. So the opening curtain begins its journey across the focal-plane aperture. The closing curtain, however, remains latched until the electromagnet lets go of the armature.

Looking behind the electromagnet, Fig. 33, you can see the auto switch. The auto switch is open at the manual settings — closed at the automatic setting. What's especially ingenious is that the auto switch is controlled by a slightly modified Spotmatic part — even though the Spotmatic has no such switch. We'll point out the part that controls the auto switch when we get into the shutter mechanism.

In Fig. 34, we have removed the electromagnet to get a better look at the auto switch and the X-sync contacts. We should first mention, however, that the electromagnet has the same type of adjustment as does the battery switch — a screw with a locking collar. The adjustment assures that the armature pin holds the auto latch engaged with the opening-curtain wind gear.

The adjustment on the electromagnet is quite critical. If the upper end of the electromagnet moves in too far, the armature may be unable to touch the core of the electromagnet. If the upper end of the electromagnet isn't in far enough, the armature pin may not hold the auto latch engaged with the closing-curtain wind gear.

However, you can remove the electromagnet without disturbing the adjustment. First, unsolder the two electromagnet wires — the brown wire and the bare wire. Then, without disturbing the position of the adjusting screw, unscrew the locking collar. Remove the cross-point screw and lift out the electromagnet.

Notice that the adjusting screw for the electromagnet threads into the camera body. A shoulder on the adjusting screw serves as a seat for the electromagnet. So turning in the adjusting screw allows the upper end of the electromagnet to move toward the back of the camera.

The switches now exposed, Fig. 34, are the previously mentioned auto switch and the X-sync contacts. You may already be familiar with the sync-contact arrangement — here again, the ES borrows from the Spotmatic design.

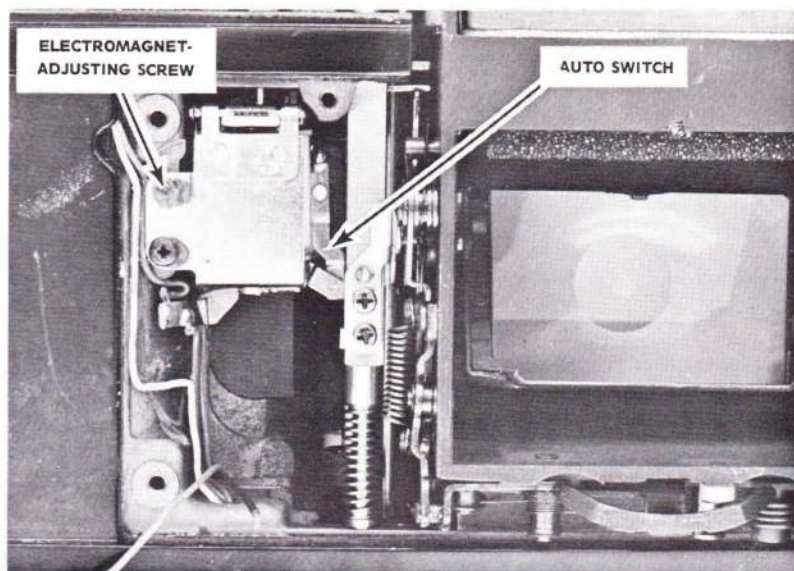

FIGURE 33

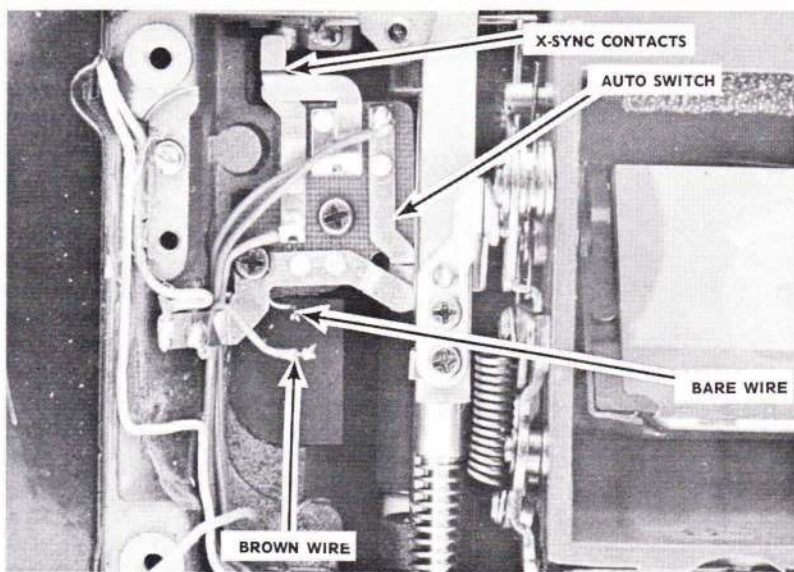

FIGURE 34

Sync Contacts in The ES

We've removed the mirror cage to better illustrate the X-sync contacts in Fig. 35 and Fig. 36. (We'll describe the procedure for removing the mirror cage in a moment.) The opening-curtain cam, Fig. 35, attaches to the bottom of a shaft on the opening-curtain wind gear. So the opening-curtain cam always rotates during the travel of the opening curtain — both during the cocking cycle and during the release cycle.

In the shutter-released position, Fig. 35, an insulated stud on the opening-curtain cam holds the X-sync contacts closed. But the closed X-sync contacts do not complete the X-sync circuit. As

in the Spotmatic, the X-sync circuit has a safety switch — the FP-sync contacts.

The mirror closes the FP-sync contacts. As you can see in the sync-circuit schematic, Fig. 37, the FP-sync contacts must be closed before the X-sync circuit is complete. And the mirror must be in the taking position before the FP-sync contacts are closed.

As you cock the shutter, the opening-curtain cam rotates in a counterclockwise direction (as seen from the bottom). The insulated stud then moves away from the X-sync contacts, allowing the contacts to

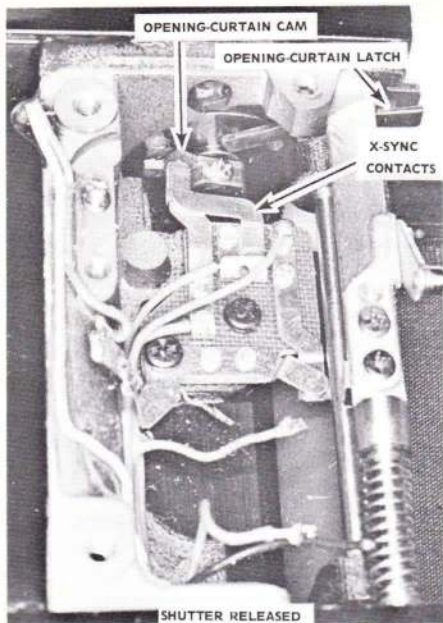

FIGURE 35

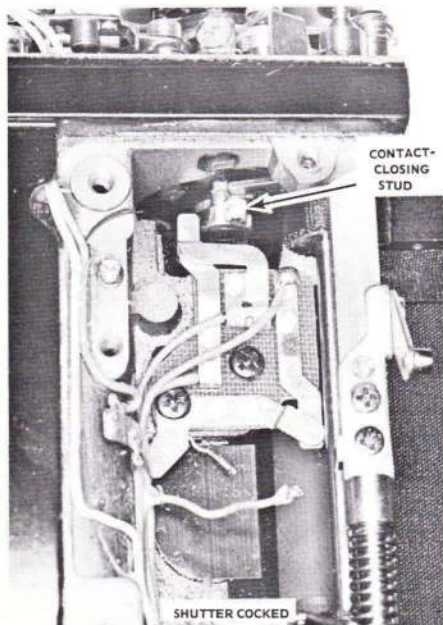

FIGURE 36

open. In the shutter-cocked position, Fig. 36, the opening-curtain latch engages the opening-curtain cam.

Now, assume that you've just depressed the release button to free the mirror. The mirror rises to the taking position and closes the FP-sync contacts. If the flash unit is plugged into the FP-sync terminal on the front plate, closing the FP-sync contacts fires the flash.

Also, the mirror-lifting mechanism kicks the opening-curtain latch out of engagement with the opening-curtain cam. So the opening curtain starts its journey across the focal-plane aperture. And the opening-curtain cam rotates clockwise.

The X-sync contacts remain open until the opening curtain clears the focal-plane aperture. By then, the opening-curtain cam has turned far enough to once again close the X-sync contacts. Since the mirror is still holding the FP-sync contacts, closing the X-sync contacts fires the flash unit plugged into the X-sync terminal.

Removing The Mirror Cage

The procedure for removing the mirror cage is again quite similar to the Spotmatic disassembly. But

there's one new twist. To take out the ES mirror cage, you have to unsolder a myriad of wires — and some of the wires aren't too easy to reach.

The wires that are tough to get to are the ones attached to the stop-down switch and sync contacts at the side of the mirror cage, Fig. 30. Obviously, working in such cramped quarters requires a delicate touch with a soldering iron. You may find it easier to leave those wires until you've separated the mirror cage from the camera body.

So we'll start the mirror-cage disassembly with the pentaprism. Disconnect and remove the two prism-cover springs. Then, lift off the prism cover.

As in the Spotmatic, two screws hold the pentaprism. The two screws, toward the front of the camera, pass through the sides of the focusing-screen frame. But the screws do more than hold the pentaprism — they also permit a shifting adjustment.

By loosening one screw — and tightening the other — you can shift the lateral position of the pentaprism. The trick in disassembly is to loosen just one of the screws; you can then lift out the pentaprism. On reassembly, tighten just the screw

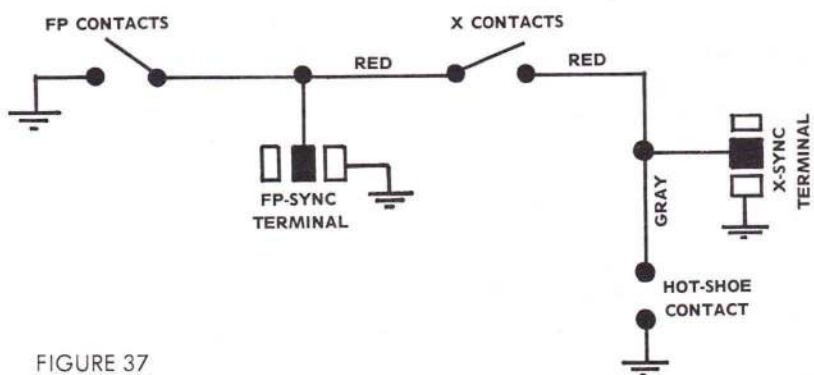

FIGURE 37

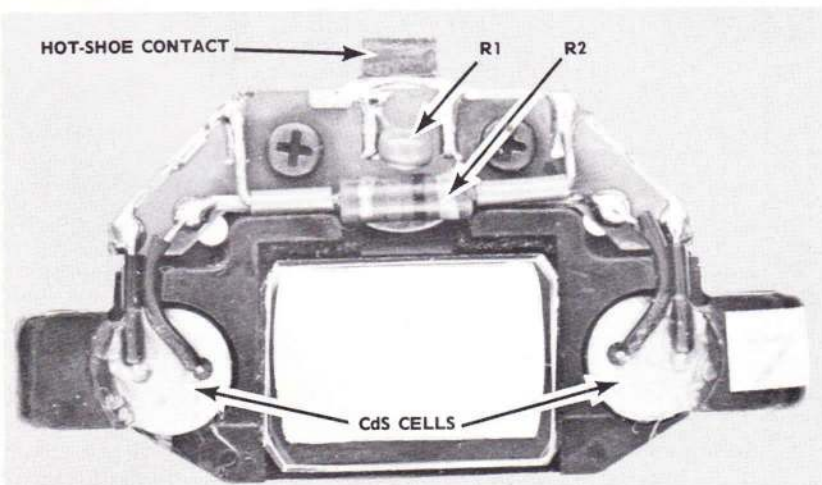

FIGURE 38

you previously loosened. That way, you won't disturb the adjusted position of the pentaprism.

Now, unsolder the wires at the photocell terminal board — the green wire, the red wire, and the gray wire. The green wire and the red wire feed current to the photocells; the gray wire connects the hot-shoe contact on the photocell terminal board to the X-sync terminal. Remove the two screws and lift off the photocell terminal board.

Fig. 38 shows the photocell terminal

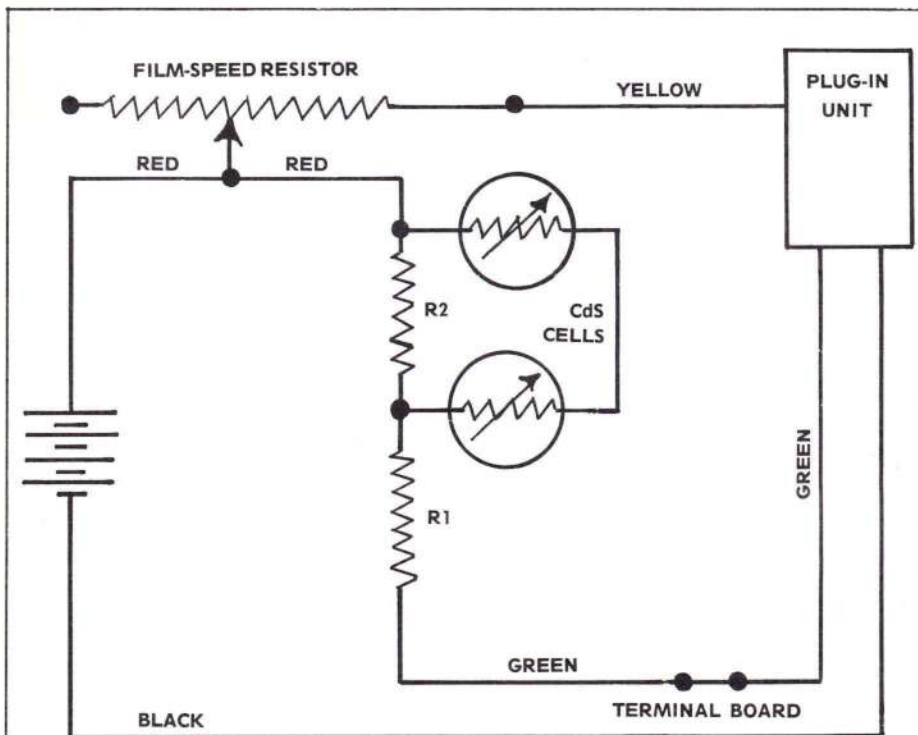

FIGURE 39

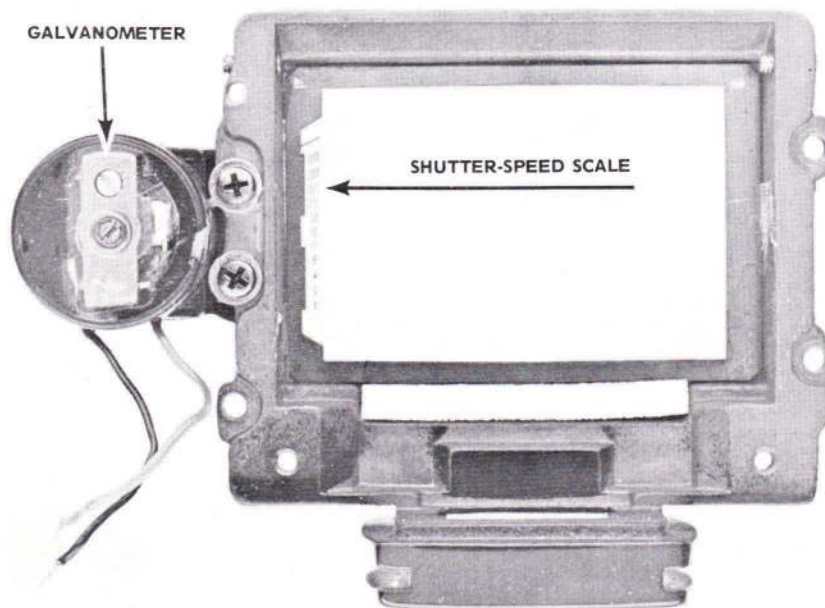

FIGURE 40

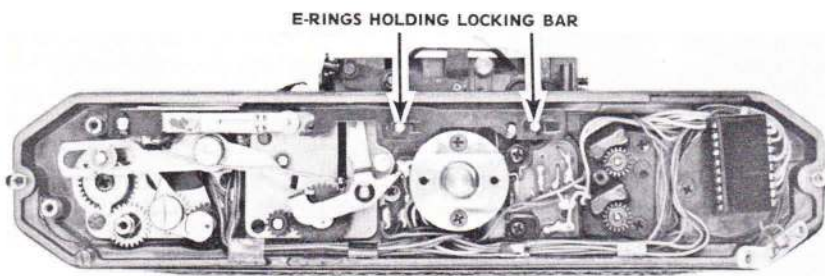

FIGURE 41

board after removal. And Fig. 39 provides the schematic arrangement of the photocells and the film-speed resistor.

To remove the focusing-screen frame, first disconnect the two wires — a red wire and a black wire — that hook the galvanometer to the film-speed-resistor terminal board. Then, remove the four focusing-screen-frame screws; notice that three are cross-point screws, one is a slotted screw. Lift out the focusing-screen frame complete with the galvanometer.

In Fig. 40, you can see the calibrations on the focusing screen. Naturally, with the pentaprism in place, the calibrations appear on the other side of the focusing screen.

Once you've removed the focusing-screen frame, you can reach the two upper-mirror-cage positioning screws. Take out both screws.

At the bottom of the camera, Fig. 41, remove the two E-rings holding the locking bar. The two support posts for the locking bar also serve as the lower retaining screws for the mirror cage. So remove the locking bar and unscrew the two support posts. Note that the two support posts are slightly different in shape and must be returned to their proper positions.

You'll also have to remove the mirror-return spring — one end of the mirror-return spring passes through the hole in the mirror-tensioning lever. And the mirror-tensioning lever remains with the mirror cage.

However, you'll find that there's not enough room to disconnect the mirror-return spring from the mirror-cocking lever — the battery switch gets in the way. So first remove the two screws at the front of the camera that hold the battery switch. Then, lift aside the battery switch (still held to the camera by two blue wires).

Be sure to lift off the insulator that closes the battery switch. The insulator, slipping over the end of the release shaft, is loose once you remove the battery switch.

Now, disconnect the hooked end of the mirror-return spring from the mirror-cocking lever. Remove the mirror-cocking-lever screw, the mirror-return spring, and the keyed washer. You can leave the mirror-cocking lever in the camera — its slotted end is still held by an E-ring to the post on the lower wind gear.

Finally, separate the mirror cage from the camera body and unsolder the remaining wires. Once you've

disconnected the wires from the stop-down switch and the sync contacts, you can completely remove the mirror cage.

Mirror Cage Operation In The ES

Operation-wise, the ES mirror cage isn't much different from the Spotmatic. As you've seen, cocking the shutter drives the mirror-tensioning lever, Fig. 42, toward the

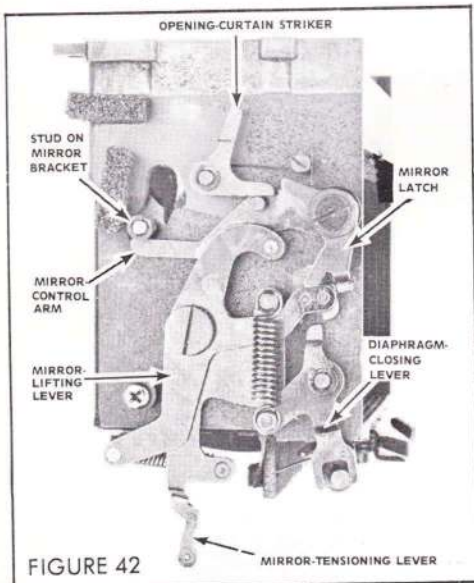

FIGURE 42

front of the mirror cage — this tensions the mirror-lifting spring. But the mirror-lifting lever is latched by the mirror latch. So the mirror cannot as yet rise to the taking position.

When you depress the release shaft, the release actuator (on the release shaft) disengages the mirror latch. The mirror-lifting lever then swings toward the front of the mirror cage. And a roller at one end of the mirror-lifting lever drives the mirror-control arm, Fig. 42, toward the top of the mirror cage.

The mirror-control arm performs two roles. For one, it contacts the stud on the mirror bracket — that raises the mirror to the taking position. Also, the mirror-control arm drives the opening-curtain striker in a counterclockwise direction. The opening-curtain striker then disengages the opening-curtain latch, Fig. 35.

The diaphragm stops down during the upward swing of the mirror. As the mirror-lifting lever starts its release travel, it frees the diaphragm-closing lever, Fig. 42. The diaphragm-closing lever then moves toward the front of the mirror cage, stopping down the diaphragm.

Much of this operation may already sound familiar to you. But the ES does feature a new mirror-cage part — the memory-switch control lever at the bottom of the mirror cage, Fig. 43.

As the mirror-lifting lever begins its mirror-lifting movement, its stud moves away from the memory-switch control lever. The spring-loaded memory-switch control lever then swings in a clockwise direction — the direction that opens the memory switch.

After the exposure, the mirror-return gear strikes the mirror-catch lever — that disengages the mirror-tensioning lever. Now, the mirror-return spring drives the back of the mirror-tensioning lever toward the back of

the mirror cage. The spring-hooking post on the mirror-tensioning lever then comes against the mirror-lifting lever. So the mirror-lifting lever moves back to its "rest" position and the mirror returns to the viewing position.

On the return route, the stud on the mirror-lifting lever strikes the tab on the memory-switch control lever. That's how the mirror-lifting lever drives the memory-switch control lever away from the memory switch. The memory switch thus closes in preparation for the next exposure.

Looking at the other side of the mirror cage, Fig. 44, you can see the switch assembly. The two sync terminals in the front plate press

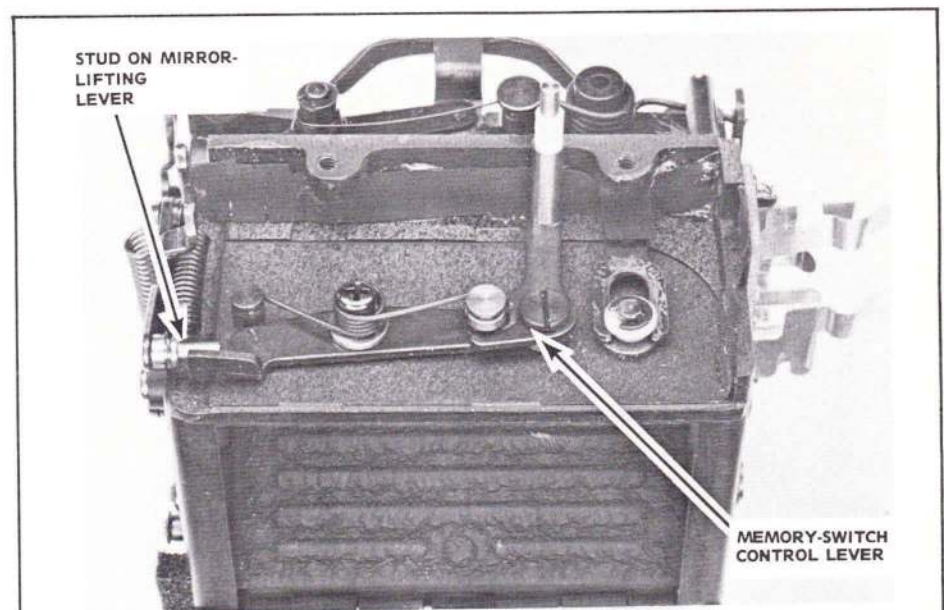

FIGURE 43

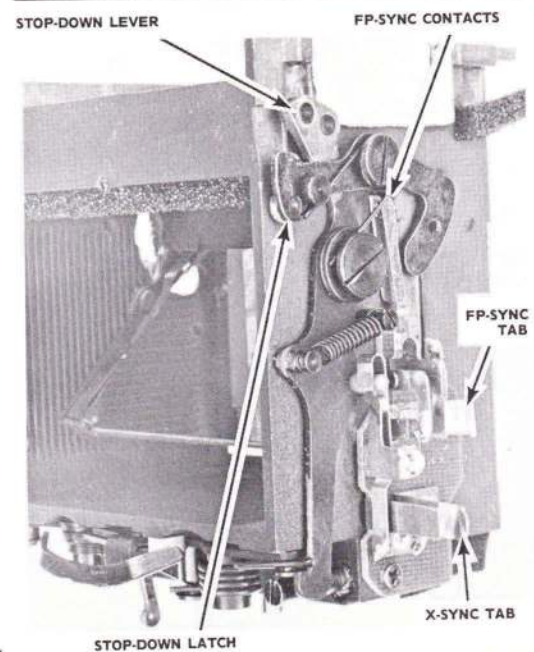

FIGURE 44

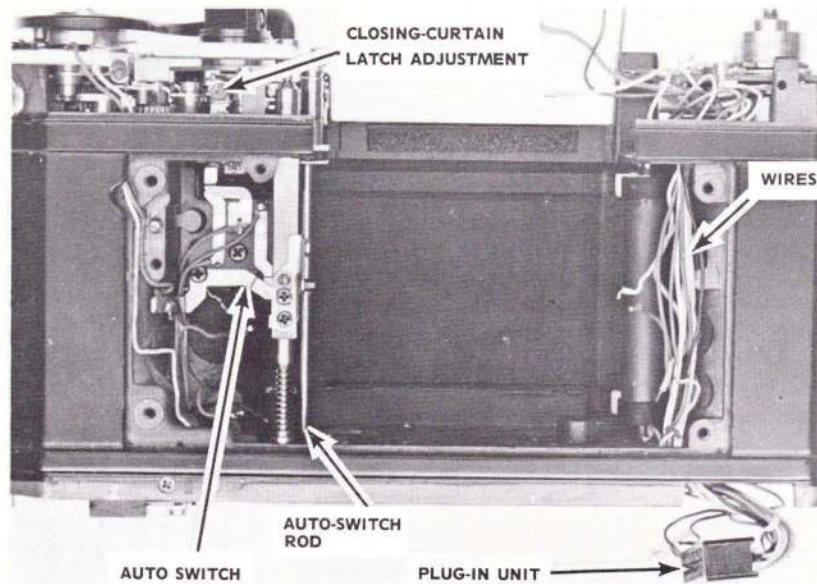

FIGURE 45

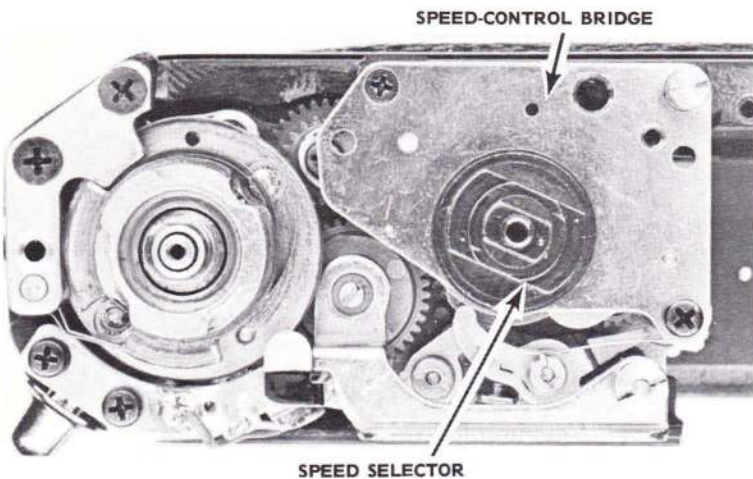

FIGURE 46

against the two tabs — one for X sync and one for FP sync. That bundle of wires remaining with the camera body, Fig. 45, sits to the front of the sync tabs.

Shutter Operation in The ES

Removing the speed-control bridge, Fig. 46, again points out the mechanical similarity between the ES and the Spotmatic. At first glance, it appears that even the pallet-control rod has been retained, Fig. 47 — yet there's no speeds escapement.

What appears to be a Spotmatic pallet-control rod is actually the auto-switch rod. The upper arm on the auto-switch rod — the auto-switch-cam follower — rides against a cam on the underside of the speed selector, Fig. 48.

Selecting the "AUTOMATIC" setting swings the auto-switch rod in a

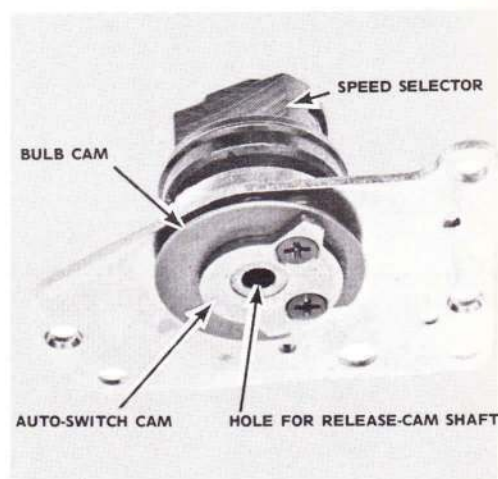

FIGURE 48

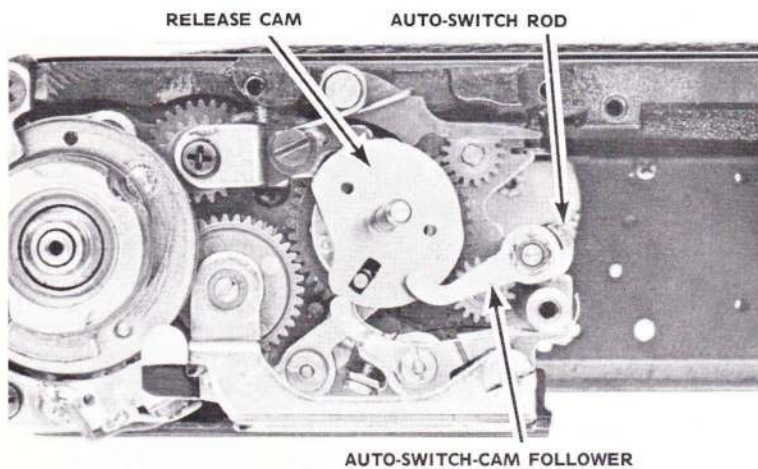

FIGURE 47

counterclockwise direction. An insulated pin on the auto-switch rod then closes the auto switch, Fig. 45. The insulated pin is about the only modification that distinguishes between the auto-switch rod in the ES and the pallet-control rod in the Spotmatic.

The other cam shown in Fig. 48 controls the bulb lever. "Bulb" action in the ES is strictly mechanical. Selecting the "bulb" setting opens the auto switch to disconnect the electromagnet. A cutout on the edge of the bulb cam then faces the control arm of the bulb lever, Fig. 49.

Depressing the release shaft releases the mirror to free the opening-curtain wind gear, Fig. 49. But the tail of the bulb lever drops into

a tapered groove in the release shaft. The latching end of the bulb lever then engages a lug on the closing-curtain wind gear (underneath the opening-curtain wind gear and not yet visible).

Consequently, the bulb lever holds the closing-curtain wind gear to keep the shutter open. Letting up on the release button then brings the release shaft against the tail of the bulb lever. So the release shaft pushes the bulb lever out of engagement with the closing-curtain wind gear, allowing the shutter to close.

You can see the closing-curtain latch just beneath the bulb lever, Fig. 49. Again, the action of the closing-curtain latch is identical to the action in the Spotmatic. Remember, the ES provides mechanically set shutter speeds of 1/60 second through 1/1000 second. These are slit-width speeds, governed by controlling the release point of the closing curtain.

Turning the speed selector over the mechanical speed range imparts an eccentric motion to the release cam, Fig. 47. As in the Spotmatic, the shaft on the release cam fits through the hole in the speed selector, Fig. 48. The release cam is the part that disengages the closing-curtain latch for the mechanical speeds.

Notice that a slot in the release cam fits over a post on the opening-curtain wind gear. So the release cam always turns as the opening curtain moves across the focal-plane aperture. Once the opening curtain releases, the closing-curtain latch holds the closing-curtain wind gear. The release cam then kicks the closing-curtain latch out of engagement according to how far the opening curtain has traveled.

The closing-curtain latch still has the conventional Spotmatic adjustment point, Fig. 45. By loosening the locking collar and turning the setscrew, you can change the position of the closing-curtain latch — this is your adjustment point for the mechanically controlled shutter speeds. Turn in the setscrew for a faster speed — out for a slower speed.

Other mechanical adjustments in the ES also mirror the Spotmatic. Adjust both the stop plate (for the opening-curtain wind gear) and the brake lever from the back of the camera. Fig. 50 shows the adjustment points with the speed-control bridge still installed.

Notice that the brake lever moves toward the opening-curtain wind gear in the shutter-cocked position, Fig. 51.

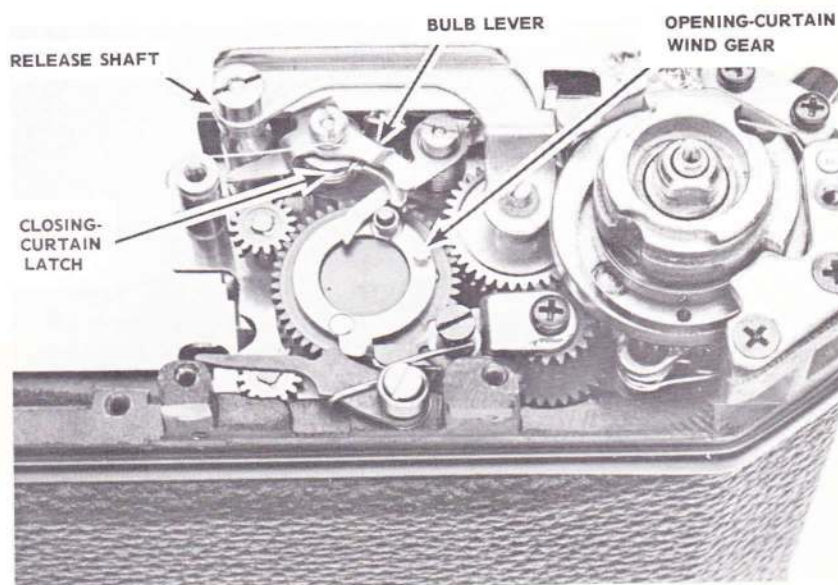

FIGURE 49

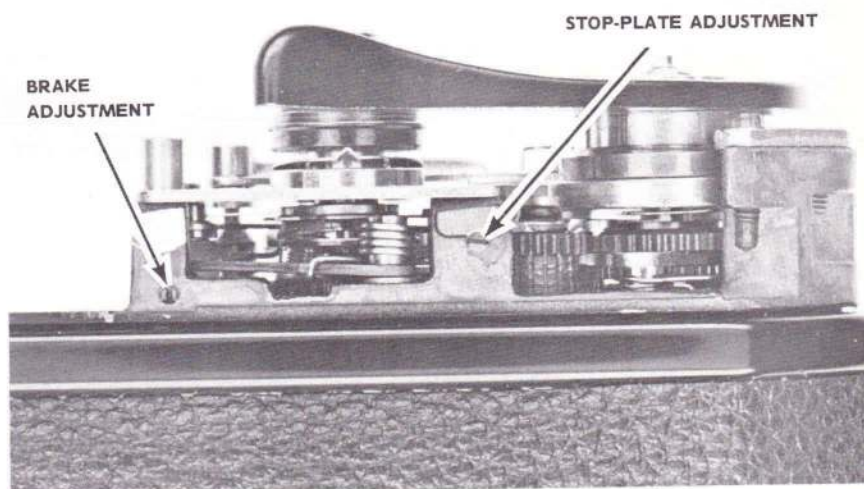

FIGURE 50

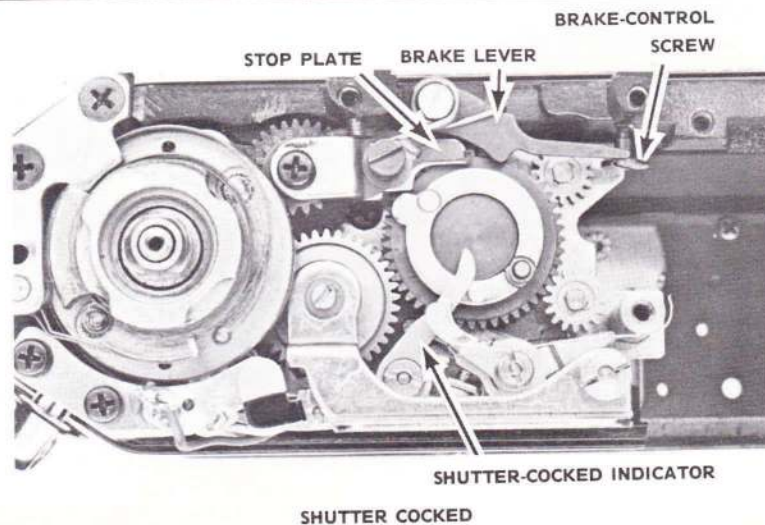
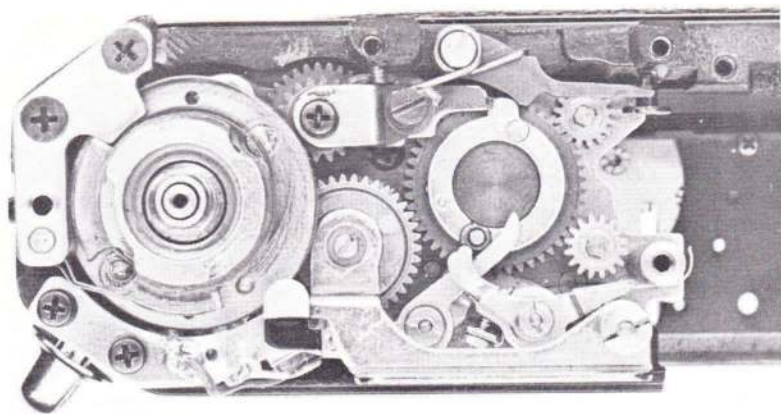

FIGURE 51



SHUTTER RELEASED

FIGURE 52

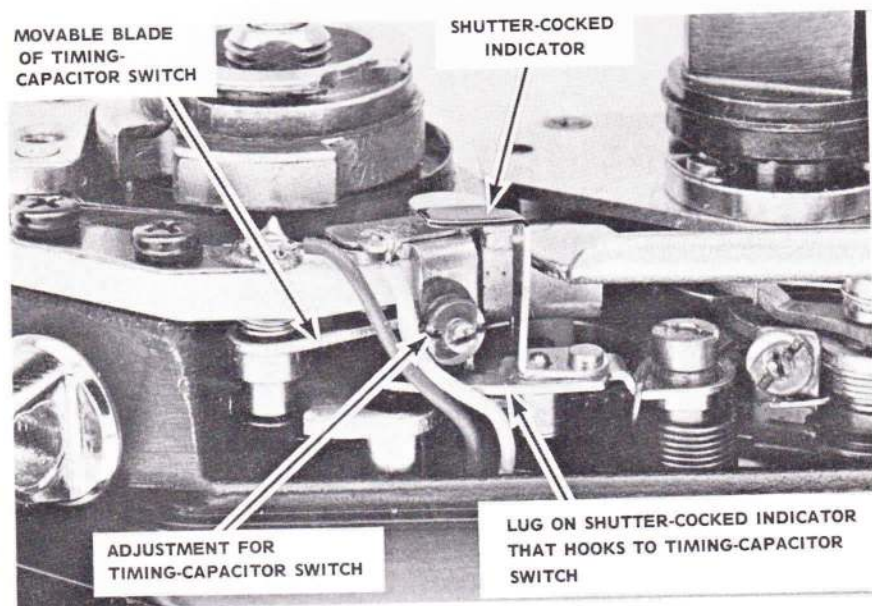

FIGURE 53

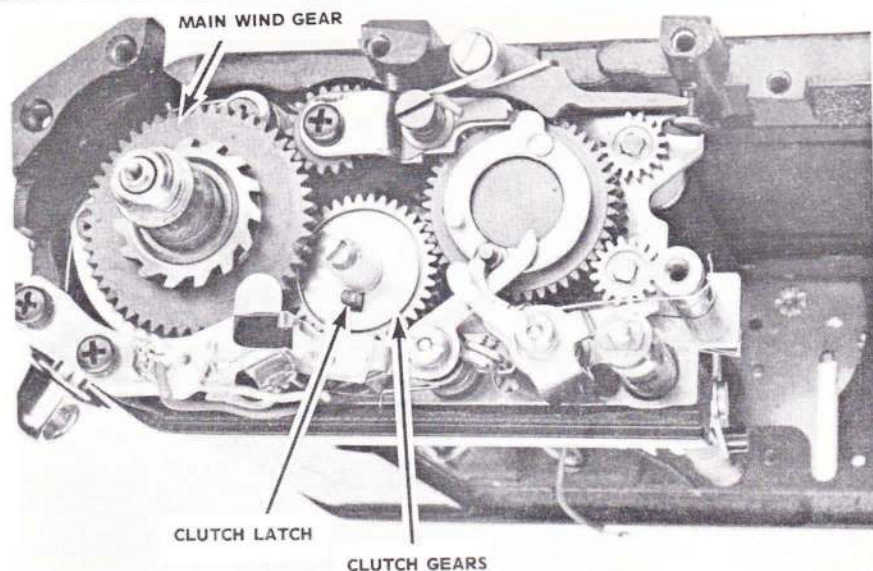

FIGURE 54

The brake-control screw acts as a stop for the brake lever; that is, it determines how far the brake lever can move toward the opening-curtain wind gear.

The opening-curtain wind gear rotates counterclockwise during the release cycle. Nearing the end of the release rotation, the opening-curtain wind gear pushes the brake lever aside, Fig. 52. So, by turning the brake-control screw, you can determine how much the brake lever opposes the rotation of the opening-curtain wind gear. Increasing the braking action may be necessary to eliminate opening-curtain bounce.

The other adjustment pointed out in Fig. 50 controls the position of the stop plate, Fig. 51. As you cock the shutter, the opening-curtain wind gear turns clockwise until its lug strikes the stop plate. Releasing the wind lever then allows the opening-curtain wind gear to recoil slightly in a counterclockwise direction — until the opening-curtain wind gear is held by the opening-curtain latch.

Adjusting the position of the stop plate is your control over the amount of overtravel for the opening-curtain wind gear. Some overtravel is necessary — it provides the clearance the opening-curtain latch needs to drop into positive engagement.

Check the overtravel in the shutter-cocked position, Fig. 51. Note the slight space gap (around 0.2mm) between the lug on the opening-curtain wind gear and the stop plate.

Fig. 51 and Fig. 52 also illustrate the action of the shutter-cocked indicator. At first glance, the action may again appear typical of the Pentax cameras. But in the ES, there's a little more than first meets the eye — the shutter-cocked indicator provides the link between the opening-curtain wind gear and the timing-capacitor switch.

In the shutter-released position, Fig. 52, the black half of the shutter-cocked indicator appears through a window in the top cover. Cocking the shutter brings a stud on the opening-curtain wind gear against the tail of the shutter-cocked indicator, Fig. 51. So the shutter-cocked indicator swings counterclockwise until the red section shows through the top-cover window. The red section says, "Danger — the shutter's cocked."

But more important, the shutter-cocked indicator opens the timing-capacitor switch. Pretty clever, getting double-mileage out of the shutter-cocked indicator. Remember,

the timing capacitor starts accepting a charge when the opening curtain starts to move.

A lug on the shutter-cocked indicator hooks to the movable blade of the timing-capacitor switch — Fig. 53 shows the switch before removing the speed-control bridge. The movable switch blade is spring-loaded — the spring tries to push the movable switch blade toward the front of the camera. Moving toward the front of the camera, the movable switch blade comes against the fixed switch blade.

In the shutter-released position, the shutter-cocked indicator holds the movable switch blade away from the fixed switch blade. The timing-capacitor switch is then open. And the timing capacitor C_t can accept a charge.

Cocking the shutter pushes the shutter-cocked indicator toward the front of the camera. Consequently, the movable blade of the timing-capacitor switch moves against the fixed blade. The timing-capacitor switch is now closed, preventing the timing capacitor from accepting a charge.

When you release the shutter, the opening-curtain wind gear frees the shutter-cocked indicator. So the spring-loaded shutter-cocked indicator pushes the movable blade of the timing-capacitor switch away from the fixed blade. Now, the timing capacitor starts charging — when the opening curtain begins to move.

The timing-capacitor switch is another part sporting the typical Pentax fine adjustment, Fig. 53. In the shutter-cocked position, the movable switch blade comes against a setscrew passing through the fixed blade. By turning the setscrew in or out, you can change the actual point at which the timing capacitor begins accepting a charge.

Practically all electronically controlled shutters you'll encounter have a similar adjustment for the timing-capacitor switch. The sooner the switch opens, the faster the resulting exposure time. The timing-capacitor switch is the normal adjustment point for the fast shutter speeds.

The remaining shutter-control parts are barely distinguishable from the Spotmatic — until we get down to the auto latch. Fig. 54 shows the shutter-cocking and releasing mechanism after removing the wind driver. Two spring-loaded pawls on the underside of the wind driver engage the ratchet teeth of the main wind gear.

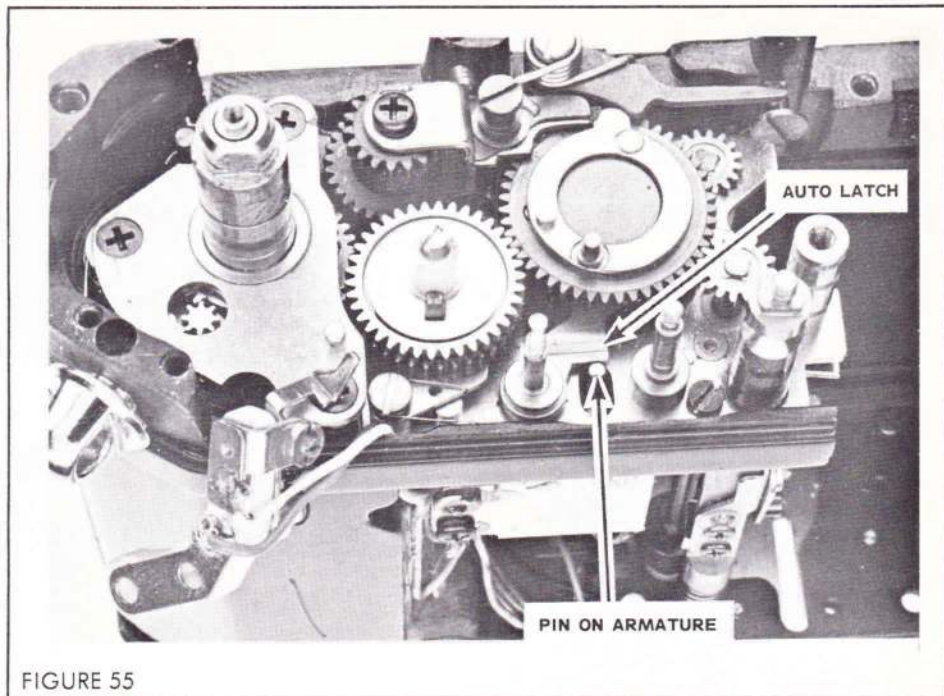

FIGURE 55

The main wind gear advances the curtains by turning the intermediate reduction gear and the two clutch gears (called "spill gears" by Honeywell). The upper clutch gear engages the opening-curtain wind gear; and the opening-curtain wind gear turns the closing-curtain wind gear during the cocking cycle.

As you well may know, depressing the release button brings the upper platform of the release shaft against the clutch latch (or "spill" in Honeywell's terminology). That disengages the upper clutch gear from the lower clutch gear. Then, once the mirror releases the opening-curtain wind gear, the opening curtain is free to travel across the focal-plane aperture.

In true focal-plane fashion, the gear train should disengage before the mirror releases. There's an adjustment on the release actuator for the proper sequence. But in the ES, the release shaft has one additional step to add to the sequence — it must close the battery switch. So in the ES, the release sequence is: first the battery switch closes, next the gear train disengages, and finally the mirror releases.

In Fig. 55, we've removed the closing-curtain latch, the bulb lever, and the shutter-cocked indicator (notice that it's also necessary to lift aside the timing-capacitor switch). And we've replaced the

electromagnet to show how the armature controls the auto latch.

The auto latch sits underneath the closing-curtain-latch/bulb-lever assembly. In Fig. 55, you can see how the pin on the armature extends through a cutout in the mechanism plate. The pin then sits against the side of the auto latch.

In the shutter-cocked position, the auto latch engages a lug on the closing-curtain wind gear. However, the auto latch doesn't actually latch the closing-curtain wind gear — it just gets in the way. If there's no current flowing through the electromagnet — so there's nothing to hold the armature — the closing-curtain wind gear merely pushes aside the auto latch and spins along its merry way.

But with the electromagnet energized, the core holds the armature. In turn, the pin on the armature holds the auto latch against the closing-curtain wind gear. So the closing-curtain wind gear is unable to push aside the auto latch as long as current flows through the electromagnet.

Setting The Curtain Tensions in The Pentax ES

Adjusting the curtain tensions is another procedure that's typically Pentax. Only in the ES you have to remove the circuit board to reach the tension-setting adjustments, Fig. 56.



Camera Problems?

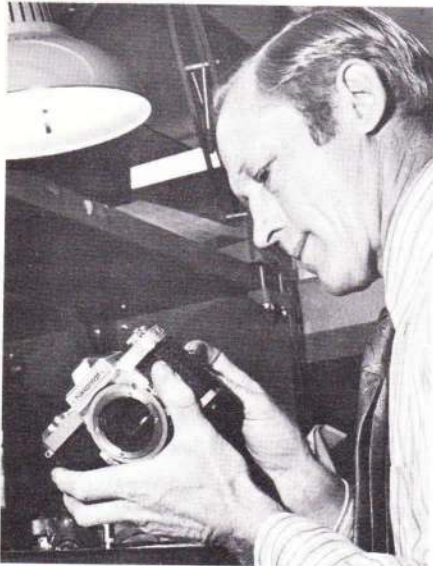

For professional service on your photo equipment, rely on your

National Camera



Your National Camera ServiShop manager is a trained, professional photo equipment technician. You know you can rely on him for

**QUALITY REPAIRS
PRECISION TESTING
WRITTEN WARRANTY**

A ServShops warranty is good at all ServShops. For a ServiShop near you see the Yellow Pages or write:

**NATIONAL CAMERA ServShops Hq.
2000 West Union Avenue
Englewood, Colorado 80110**

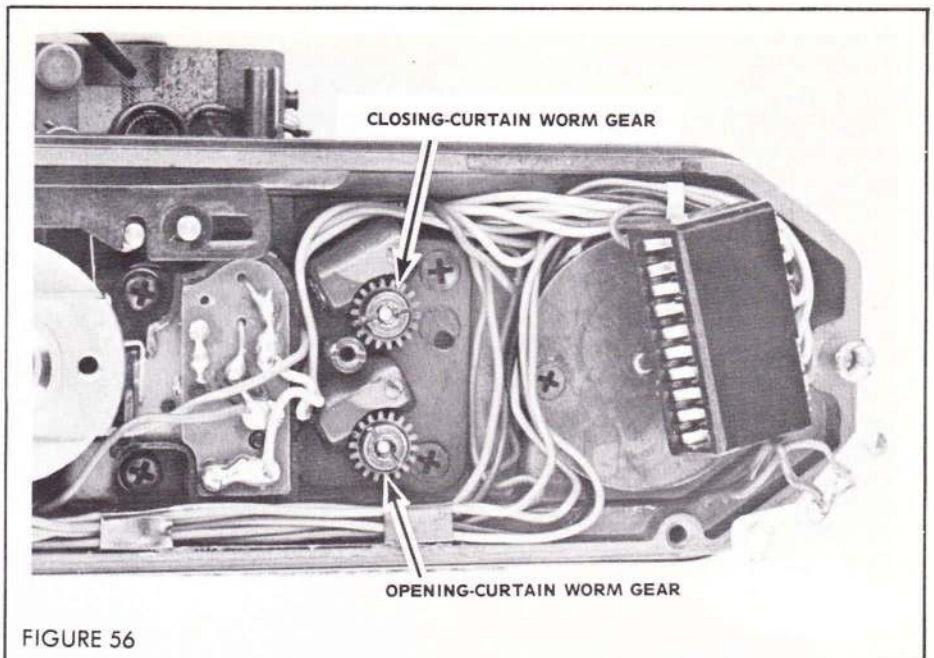

FIGURE 56

However, the curtains in our sample ES zipped across the focal-plane aperture about 2 milliseconds faster than Spotmatic specs. The edge-to-edge travel time in the Spotmatic is 14.5 milliseconds — our ES clocked in at 12.5 milliseconds. That translates to 11.4 milliseconds using the National Camera Travel-Time Mask.

Conclusions On The Pentax ES

It seems such a short time ago that we first heard rumors of a fully automatic Pentax — a "dream" camera on the drawing boards. But already the Pentax ES is off and running as Honeywell's top-of-the-line 35mm SLR.

In sales appeal, there's little to hold it back (except maybe the price tag). It seems the ES has it all — full automation in a top-quality SLR, electronically controlled focal-plane shutter, through-the-lens metering, multi-coated lenses, and the magic of the "Honeywell Pentax" nametag. And when you add the words "solid-state dependability" — no matter what you're selling — you have instant customers.

The ES model we were privileged to explore and illustrate may not be the first one you'll see in your neighborhood. There's also a Japanese version, not intended for export, that's been riding to the U.S. in the gadget bags of servicemen. Plus, there's already a new, modified ES — the ES II.

As we're preparing this report, the ES II is still waiting in the wings. But it may be introduced to the camera-buying public before we actually go to press.

The ES II, it appears, has an answer to everything that might be considered a drawback in the ES. For example, there's now a lock lever on the release that prevents accidentally closing the battery switch. So, when the camera's not in use, you can prevent unnecessary battery drain.

Also, if you're a prospective buyer who likes the self-timer feature, you'd best wait for the ES II. The ES II adds a delayed-action mechanism — location-wise and operation-wise, the same as in the Spotmatic.

To provide room for the self-timer, the ES II has its battery compartment at the bottom of the camera. Rather than using the 6-volt silver-oxide battery, the ES II gets its power from four 1.5-volt silver-oxide cells.

Other modifications include a second "AUTOMATIC" speed-knob setting. The new setting — identified by a square index — closes viewfinder blinds to prevent stray light entry. And additional focusing-screen calibrations now announce the ultra-long exposures — 2, 4, and 8 seconds.

The ES II looks like a near-ultimate in camera sophistication. But as fast as these Pentax people are moving, we'd hesitate to predict how long the ES II will reign. At least, perhaps, until the development of an ES III. ♦