

# PENTAX 6x7

The new cameras are marked 67 rather than 6x7

**Battery:** 1 6V silver oxide 544, negative ground

**Product numbers:**

23400—original product, parts no longer available

23401—current product

**Note:** For the differences between the original product and the current product, see, *Revised Sections*.

## QUICK REFERENCE

Operation with back open	pg. 12
Adjustment procedures	pg. 12
Disassembly	pg. 15
Current draw	pg. 29
Troubleshooting	pg. 29
Switch checks	pg. 33
Revised sections	pg. 26
Operating instructions	pg. 35
Wiring pictorials	30, 31, 32
Schematic	pg. 28
Part numbers	pg. 36

## ADJUSTMENT LOCATIONS

2nd-curtain brake	A	fig. 4
1st-curtain brake	B	fig. 4
Mirror angle	C	fig. 4
Battery check	D*	fig. 4
Shutter speed (slow)	E*	fig. 4
Shutter speed (fast)	F*	fig. 4
Travel time, 1st curtain	G	fig. 5
Travel time, 2nd curtain	H	fig. 5
A-M switch	I	fig. 7
Magnet	J	fig. 16
Coupler slider	K	fig. 20
Focusing screen	L	fig. 20
1st-frame position	M	fig. 29

\*Fig. 4 shows the old-style circuit board (brown board). The variable resistors are in different locations in the new-style board (green board), Fig. 21. Fig. 6 shows the adjustments on both boards.

## ADJUSTMENT VALUES

**Curtain-travel time:**

22.9ms (62mm distance—Pentax probe)

19.5ms (53mm distance)

**Flange-focal distance:** 84.95

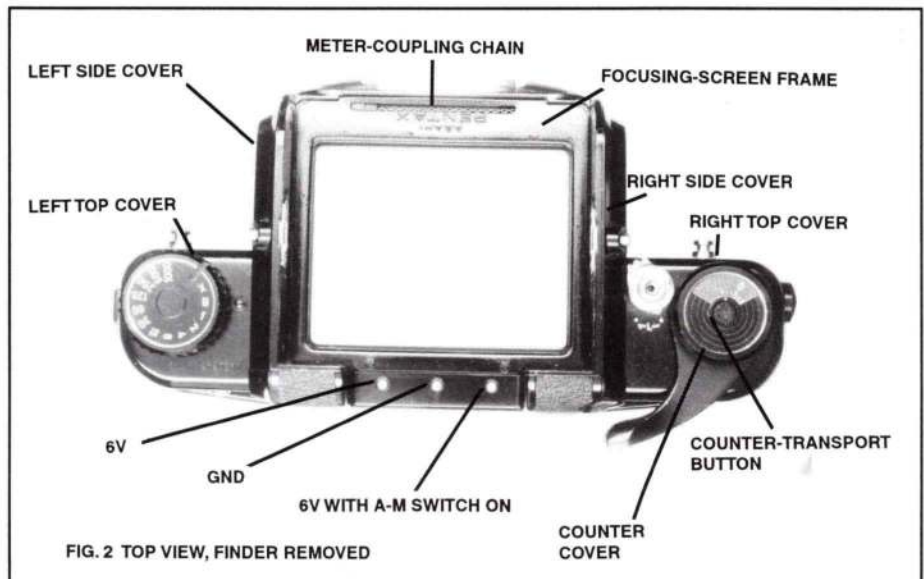
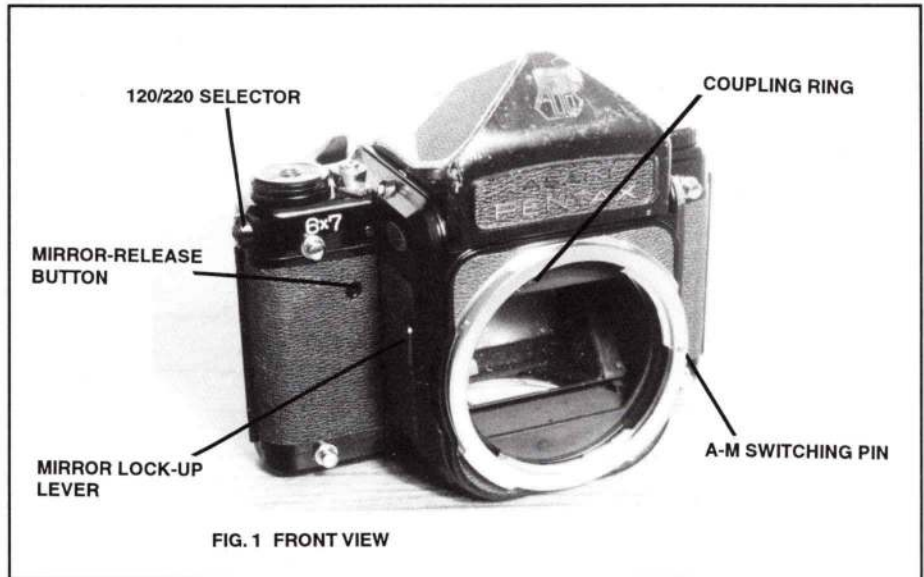

±0.04mm (front of lens-mounting ring to film rails)

**X-sync speed:** 1/30

**Battery-test voltages:**

5V—lamp turns on

4.9V—lamp does not turn on

**Initial tensions:**

- 1st & 2nd curtain: 2 1/2 turns

- wind-lever spring: 180° (1/2 turn)

- restoring spring (spring inside

restoring gear that returns mirror,

Fig. 30): 180°~220°

-flip-up spring (spring under mirror-

actuator disk that raises mirror,

Fig. 30): 90~120°

- timing-cam spring (under timing

cam, Fig. 30): 90°

- counter-return spring: 2~4 turns

**2nd-curtain position:** 5.2 ±0.2mm, lead edge of 2nd-curtain bar to lead edge of focal-plane aperture with 2nd-curtain gear held by 2nd-curtain latch (marked by line on back of mirror-housing frame)

**Curtain overlap:** 0.1 +0.2, -0.1mm, lead edge of 1st-curtain bar to lead edge of 2nd-curtain bar, curtains in charged positions held by latches (around a 1-bar overlap with the curtains advanced halfway across the aperture)

**A-M switching pin:** With the lens removed, the A-M switching pin, Fig. 1, should extend 1.7mm from

the lens mount; the A-M switch should be open. When you push in the A-M switching pin until it extends 1.2mm from the lens mount, the A-M switch should close.

**First-frame position:** 220mm between start mark on paper backing and lead edge of first frame

**Test voltages at finder contacts:** see Fig. 2

## OPERATION WITH BACK OPEN

With the back open—or with no film in the camera—the wind lever advances freely. The lever pawl, Fig. 12, holds the pawl in the main gear disengaged. As you advance the wind lever, the top section of the main gear turns without turning the gear section. As a result, neither the mirror nor the shutter charges. To operate the camera:

1. Wedge in the reset actuator plate, Fig. 14, through the camera-body slot as shown in Fig. 3. Pentax uses a special *coin plate* (dealer item supplied with new cameras—see drawing below) to wedge in the reset actuator plate.

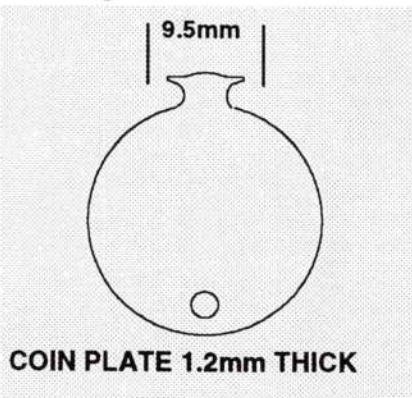

2. With the reset actuator plate pushed in, the film-metering roller will advance the counter dial. Turn the film-metering roller, Fig. 3, to advance the counter dial past the "1" position.

3. Advancing the wind lever now charges the mirror and shutter.

## ADJUSTMENT PROCEDURES

**Note:** When checking curtain-travel times and shutter speeds, it may be

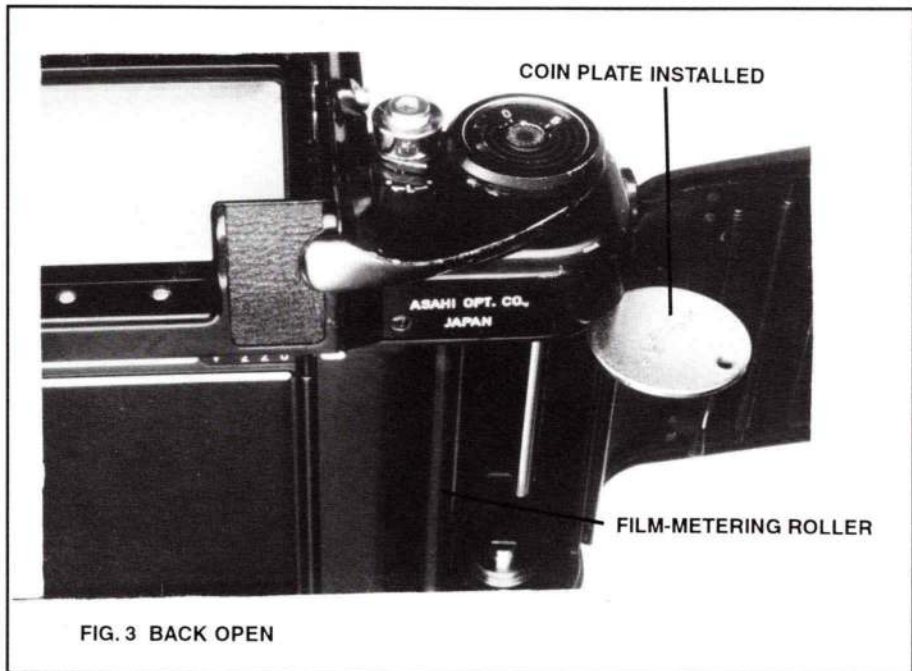

FIG. 3 BACK OPEN

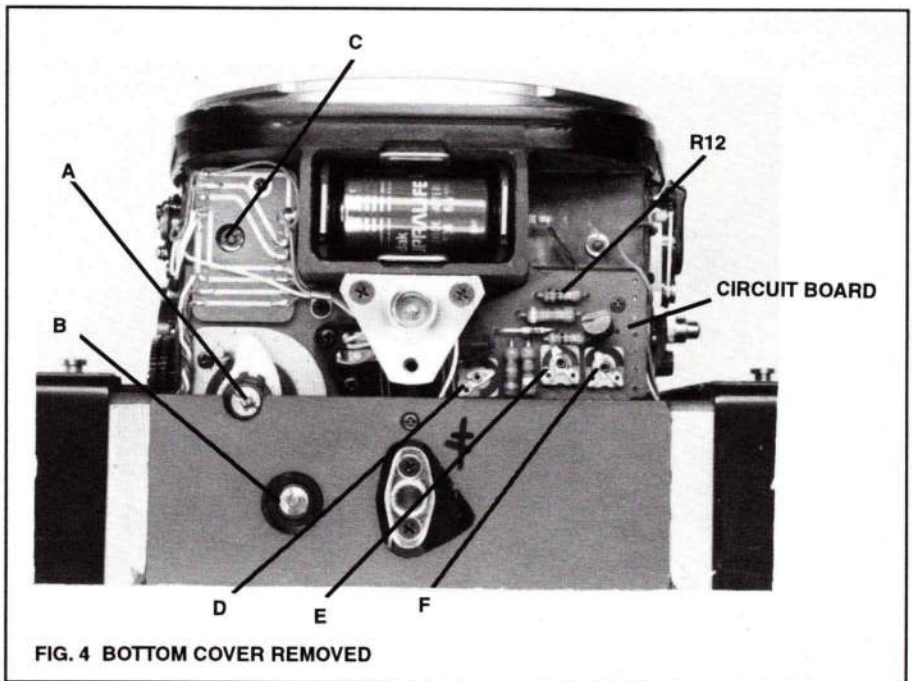

FIG. 4 BOTTOM COVER REMOVED

awkward to hold in the reset actuator plate. If you haven't replaced the right-side top cover, you can remove the lever pawl, Fig. 12. The shutter will then operate without the coin plate. Or make your shutter tests before you replace the lever pawl.

### 1. Curtain-travel times

Loosen the setscrews on top of the worm housings, Fig. 5. Adjust the curtain-travel times by turning the worms from the back of the camera.

*1st curtain—turn worm counterclockwise to increase tension, clockwise to decrease tension*

*2nd curtain—turn worm clockwise to increase tension, counterclockwise to decrease tension*

**Caution:** Since you're turning the back of the 1st-curtain worm, it's possible to push the worm out of its housing. Hold the front end of the worm at the front of the housing with a flat tool (such as a — head screw-

driver). Then use a small – head screwdriver to turn the worm from the back of the housing.

## 2. Shutter speeds

a. Check at 1 second. Adjust the slow-speed VR, Fig. 6, for an accurate exposure time. Turn the wiper counterclockwise for a faster speed, clockwise for a slower speed.

b. Check at 1/1000 second. Adjust the fast-speed VR, Fig. 6, for an accurate exposure time. Turn the wiper counterclockwise for a faster speed, clockwise for a slower speed.

3. **A-M switch.** Set a vernier or depth micrometer to 1.2mm. Use the vernier to push in the A-M switching pin, Fig. 1. The A-M switch, Fig. 7, should close. Adjust with I, Fig. 7.

4. **Focusing screen.** Remove the focusing-screen frame, Fig. 2 (2 post screws at front, 2 + head screws at back)—watch for washers under the focusing-screen frame (normally cemented). Adjust the focusing screen by turning the 3 adjustment screws (L in Fig. 20—the photo shows 2 of the 3 adjustment screws).

**Note:** Pentax uses a depth micrometer to set the focusing-screen height and to level the focusing screen. Alternately, install the lens and use a loupe to check the focusing-screen image. Turn the adjustment screws to correct the focus at the center and at all 4 corners of the focusing screen.

5. **Magnet:** After loosening screw J, Fig. 16, you can shift the magnet core up or down. The adjustment changes the clearance between the core and the armature. With the shutter charged, push the magnet armature, Fig. 16, against the magnet core; there should now be a space gap of 0.1mm between the latching section of the armature and the edge of the mirror-coupling cam. Further adjustment may be necessary for proper operation with the particular camera.

6. **Coupler slider.** With the tab on the coupler ring 0.2–0.4mm from the center line, Fig. 8, the edge of the coupler slider should align as shown

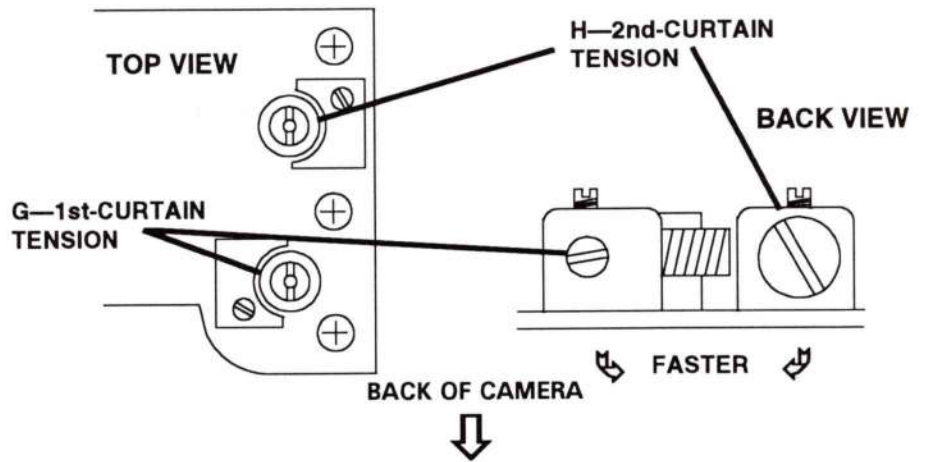

FIG. 5 TOP, SPEED-KNOB END

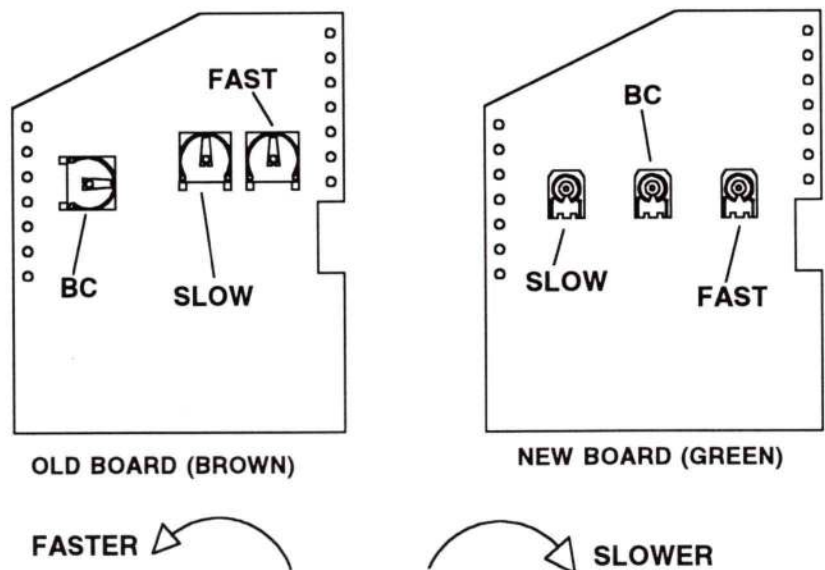

FIG. 6 ADJUSTMENTS ON OLD-STYLE CIRCUIT BOARD (LEFT) AND NEW-STYLE CIRCUIT BOARD

in Fig. 8. Shift the pulley—K in Fig. 20— after loosening its screw (reach the adjustment by removing the focusing-screen frame, Fig. 2).

## 7. Curtain brakes:

**Increase braking action:** Turn out the left-hand setscrew on top of the adjustment nut (clockwise). Then turn in the left-hand adjustment nut (counterclockwise). After setting the adjustment, turn in the setscrew to its stop (counterclockwise).

**Decrease braking action:** Turn out the left-hand adjustment nut (clockwise). Then turn in the left-hand

setscrew (counterclockwise) to hold the adjustment.

8. **Flange-focal distance.** Adjust with spacers under the lens-mounting ring at the screw-hole positions. The W8 washers are available in thicknesses of 0.02mm, 0.03mm, 0.07mm, 0.1mm, 0.15mm, 0.2mm, 0.25mm, and 0.3mm.

9. **Mirror angle.** Adjust the mirror angle with the adjustment screw at the release side of the mirror box—adjust with setscrew C, Fig. 4.

With the mirror in the down (view-

ing) position, there should be a space gap of 0.3mm between the other mirror damper (speed-knob side of mirror box) and the mirror. Adjust with the other damper-adjustment setscrew (to the right of the battery box in Fig. 4).

#### 10. Wind overtravel

##### a. Mirror-charge mechanism

Adjust the overtravel on the mirror mechanism by changing the timing between the mirror-charge 1st gear and the main gear, Fig. 12.

*To increase overtravel, turn the mirror-charge 1st gear clockwise.  
To decrease overtravel, turn the mirror-charge 1st gear counterclockwise.*

##### b. Shutter curtains

Adjust the overtravel on the shutter by changing the timing between the curtain-charge gear and the main gear, Fig. 12.

*To increase overtravel, turn the curtain-charge gear clockwise.  
To decrease overtravel, turn the curtain-charge gear counterclockwise.*

##### c. Checkpoints

Check the overtravel on the shutter, mirror, and main gear as follows:

##### (1) Overtravel on shutter

From the top of the camera, watch the curtain latches, Fig. 18, and the winding-lever ratchet, Fig. 13, as you advance the wind lever. Near the end of the wind stroke, you should see the 2nd-curtain latch (lower latch) drop into engagement with the 2nd-curtain gear. You should also see the winding-lever ratchet disengage and move counterclockwise to free the main gear.

The winding-lever ratchet should swing counterclockwise at the same time or slightly after the 2nd-curtain latch engages the 2nd-curtain gear. If the winding-lever ratchet disengages before the 2nd-curtain latch engages the 2nd-curtain gear, the wind lever can return—even though the 2nd curtain hasn't latched.

Alternately, you can slowly advance

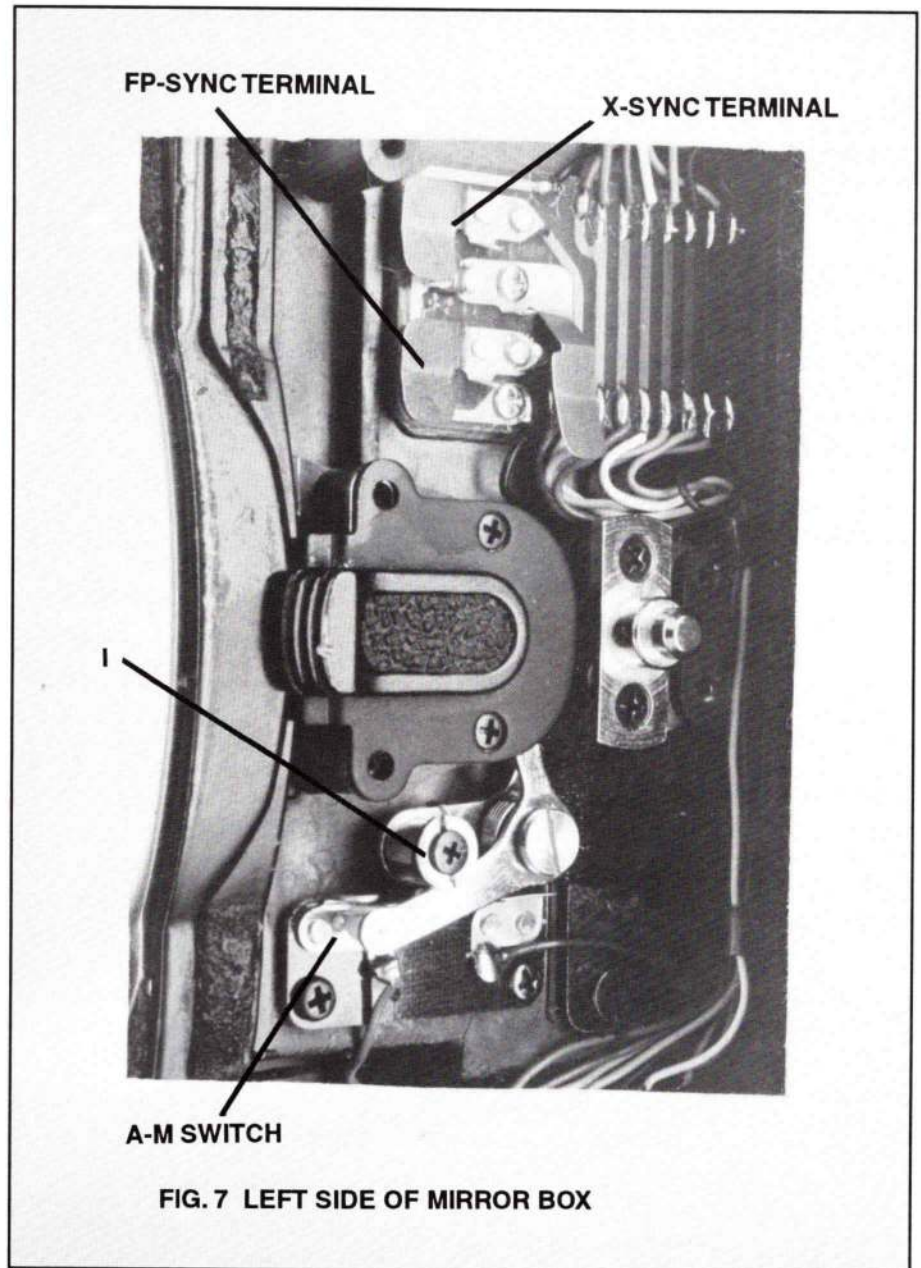

FIG. 7 LEFT SIDE OF MIRROR BOX

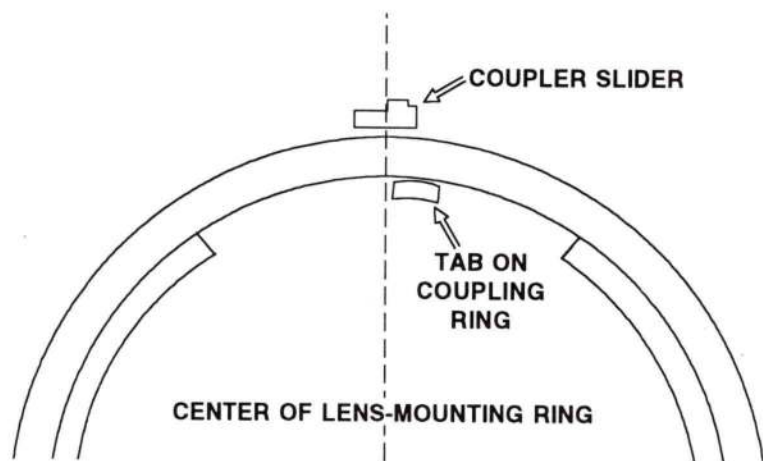

FIG. 8 FRONT OF LENS-MOUNTING RING

the wind lever—stop advancing the wind lever the moment you see the winding-lever ratchet disengage. Then operate the camera at a slow shutter speed. If the 2nd-curtain latch hasn't engaged, the shutter won't time out (the curtains cross the aperture together).

**(2) Overtravel on mirror-charge mechanism**

Check with the mirror and shutter charged. Turn the timing cam, Fig. 16, in a counterclockwise direction to its stop (very slight rotation). There should now be a space gap between the timing cam and the end of the timing-checker lever of at least 0.2mm.

**(3) Main gear**

Advance the wind lever until the winding-lever ratchet disengages (moves clockwise). The stop lug on the main gear should then come against—or be within 0.2mm of—the wind-lever stopper, Fig. 12. Pentax supplies the wind-lever stopper in three sizes for adjustment—C27a, C27b, and C27c. If the space gap with C27a is excessive, use C27b.

**11. First-frame position.** Loosen screw M, Fig. 29. Then slide the counter-advance worm on the lever to change the distance between the 1st frame and the start mark on the paper backing. Ideally, the lead edge of the first frame should be 220mm from the start mark. But the adjustment is acceptable if the distance is greater than 215mm—as long as you get 10 frames on 120 film. See *Other Comments #1* (procedure for marking test film).

**DISASSEMBLY**

Covers	pg. 15
Main gear	pg. 17
Wind-lever shaft assy	pg. 19
Meter chain	pg. 21
Mirror box	pg. 22
Curtain gears, timing	pg. 23
Curtain latches	pg. 24
Brakes	pg. 25

**Locations of left-hand threads:** nut holding counter-dial housing, Fig. 10, adjustment nuts and setscrews for curtain brakes, Fig. 4 (A and B)

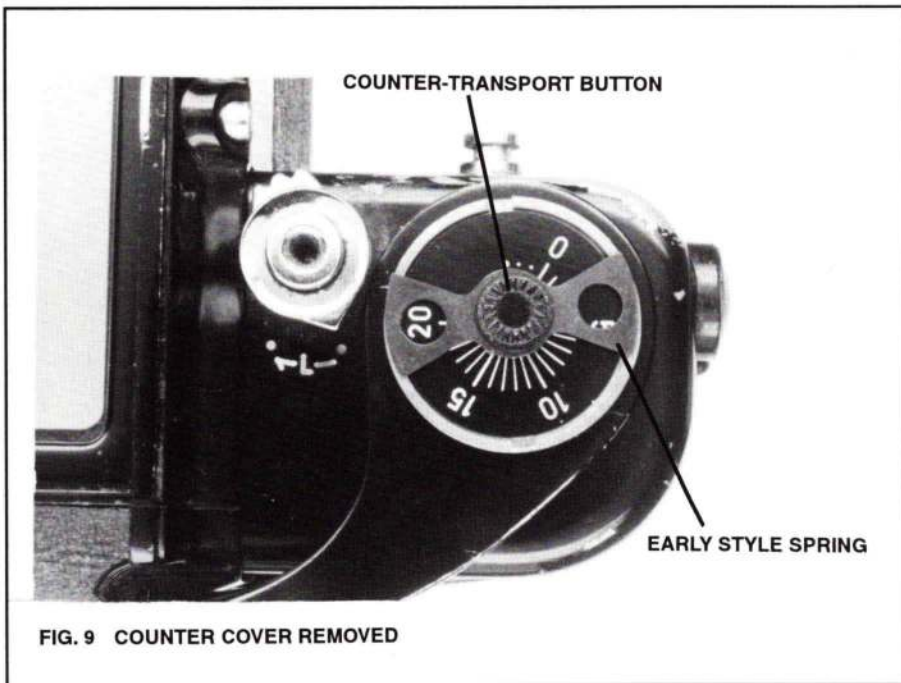

FIG. 9 COUNTER COVER REMOVED

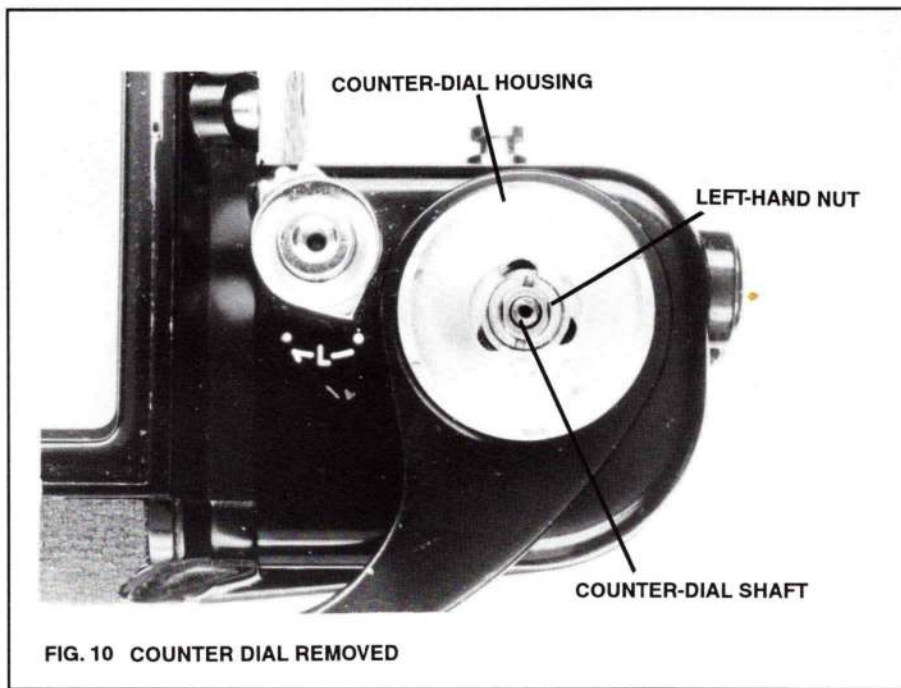

FIG. 10 COUNTER DIAL REMOVED

**Settings for disassembly:** shutter released and back cover open to remove counter dial

**Precautions:** watch for adjustment washers—the sizes and locations vary according to the individual camera

**Sequence to remove covers:**

**Right top cover (wind side)**  
1. remove counter cover, Fig. 2 (loosen 3 setscrews)

**Note:** The counter-transport button and spring are loose, Fig. 9. Early cameras use a flat spring; the counter-transport button fits in the hole at the center of the spring, Fig. 9. Later cameras use a coil spring under the counter-transport button. The coils of smaller diameter go down—the bottom (smallest) coil fits over the counter-dial screw. There may also be a small washer fitting around the counter shaft.

2. remove counter dial (1 screw)

**Caution:** Avoid pushing down the counter-dial shaft, Fig. 10—if the counter-dial shaft moves down, you'll lose the initial tension on the counter-return spring. Retensioning the counter-return spring requires removing the wind-lever shaft assembly, Fig. 15.

3. unscrew left-hand nut holding counter-dial housing, Fig. 10
4. lift counter-dial housing and allow wind-lever spring to unwind
5. remove counter-dial housing (disconnect from upper end of wind-lever spring)

**Note:** The wind-lever spring normally stays with the main gear, Fig. 12. A straight end at 90° to the spring body fits into a hole at the top of the main gear.

6. unscrew wind-lever nut (normal thread, but may be very tight—hold the wind lever as you unscrew the wind-lever nut)
7. remove spring washer and flat washer(s) above wind lever
8. remove wind lever
9. remove black dust seal under wind lever
10. remove 120/220 selector, end of right top cover, Fig. 1 (1 screw, center)
11. remove 2 screws holding right top cover (front and back)
12. remove right top cover (slide toward wind-lever end of camera body—the housing for the 120/220 selector may come loose)

#### Reassembly highlights, counter-dial housing:

1. The counter-dial housing has 3 slots for hooking the upper end of the wind-lever spring, Fig. 10. Align the counter-dial housing with the flat sides of the wind-lever shaft so that 1 slot faces the back of the camera—hook the upper end of the wind-lever spring to this slot.
2. Lift the counter-dial housing to clear the flat sides of the wind-lever shaft. Then rotate the counter-dial housing 180° in a clockwise direction to tension the wind-lever spring. Seat the counter-dial housing over the flat sides of the wind-lever shaft.

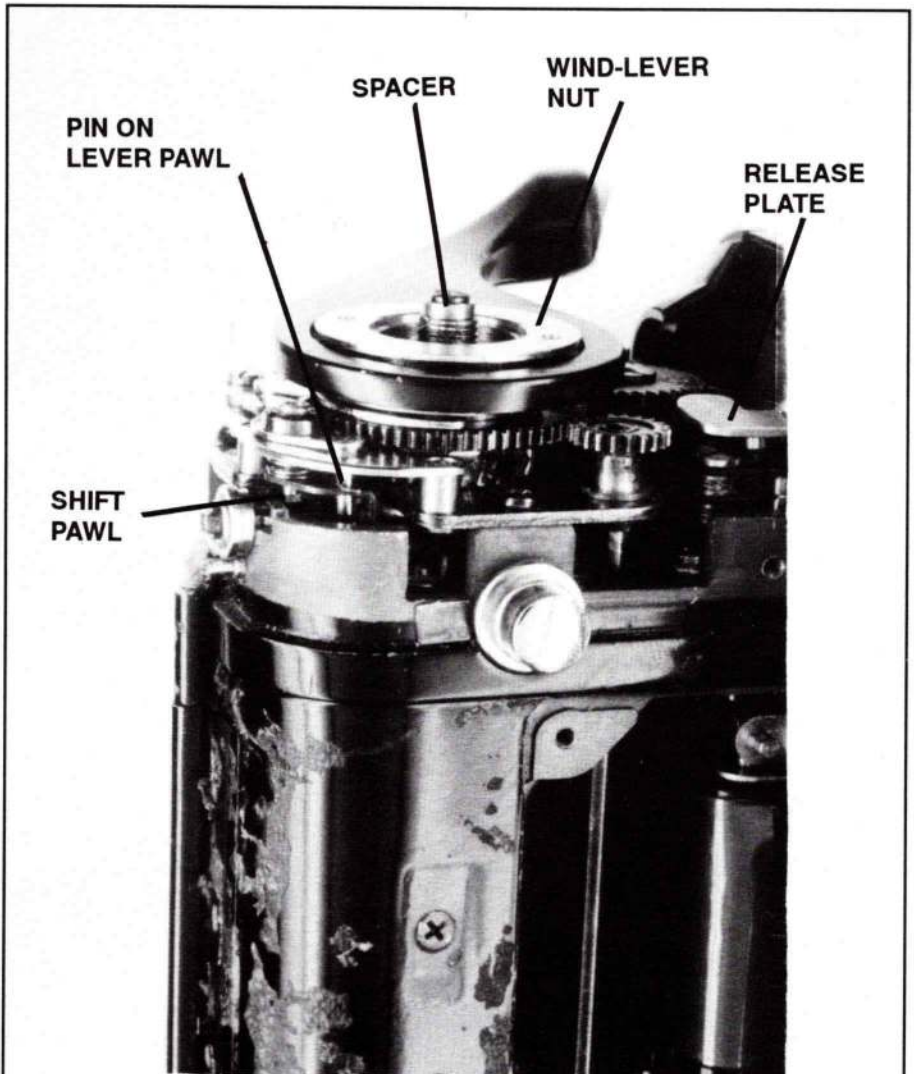

FIG. 11 RIGHT TOP COVER REMOVED, FRONT VIEW

3. If necessary, you can increase the initial tension of the wind-lever spring by 60°. Use a different spring-hooking slot in the counter-dial housing. However, do not increase the initial tension more than 60° from the normal 180°. Excessive initial tension may damage the wind-lever spring.

#### Left top cover (speed-knob end)

1. remove speed knob (loosen 3 setscrews, outer circumference—note dust seal under speed knob)
2. remove 3 top-cover screws
3. remove left top cover (slide toward back-latch end of camera body)

#### Reassembly:

1. Turn the brass shutter-dial base

until its notch faces the front of the camera (bulb setting).

2. As you seat the left top cover, make sure the inside end of the battery-test button passes to the back of the BC-switch contact. Replace the dust seal.

3. Seat the speed knob and align the B calibration with the red indicator for the battery-check lamp.

#### Side covers

**Note:** It's normally not necessary to remove the left side cover, Fig. 2—even to remove the mirror box. Remove the right side cover, Fig. 2, for most repairs.

1. remove 2 strips of leatherette, 1 on each side cover

2. remove 3 machine screws holding each side cover (under leatherette)
3. remove screws, 2 for each side cover, from inside the finder mount (with the current product, the screws inside the finder mount are self-tapping)
4. remove side covers

**Note:** The 2 lock-release buttons and springs for the finder will be loose. On reassembly, position the springs with the smaller ends facing the lock-release buttons.

#### Bottom cover

1. remove battery holder
2. remove leatherette, bottom of camera
3. remove 3 side screws holding bottom cover (2 on back-latch side, 1 on wind-lever side)
4. remove 2 screws holding bottom edge of bottom cover (from back)
5. remove bottom cover

#### Front covers

**Note:** For most repairs, you don't have to remove the front cover at the speed-knob side of the lens mount.

1. remove leatherette sections, front of each front cover
2. remove front covers (2 screws each)

#### Operation with right top cover removed:

1. Replace the wind lever and the wind-lever nut, Fig. 11.
2. As a precaution, temporarily replace the counter dial to prevent the counter-dial shaft from moving down. If the counter-dial shaft moves down slightly, the film-metering cam may disengage from its stop pin on the underside of the wind-lever shaft assembly, Fig. 15. The counter-return spring then loses its initial tension. To retension the counter-return spring, it's necessary to remove the wind-lever shaft assembly, Fig. 15.

**Note:** Alternately, you can use a spacer to prevent the counter-dial shaft from moving down. Spacer dimensions: OD—4mm, ID—2.4mm, thickness—1.2mm. Install the spacer and the counter-dial screw as shown in Fig. 11. If you replace a wind-

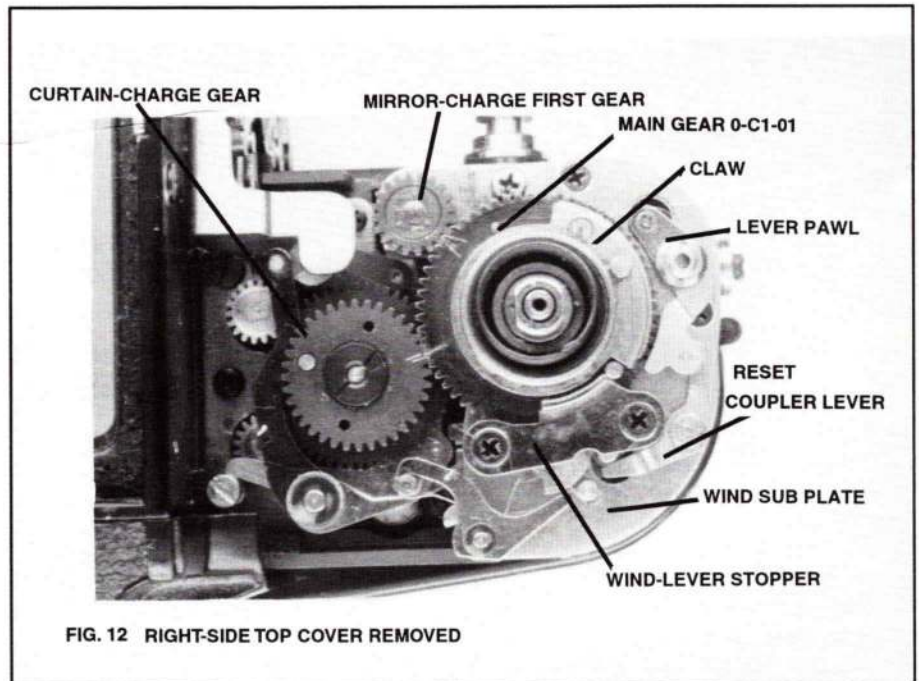

FIG. 12 RIGHT-SIDE TOP COVER REMOVED

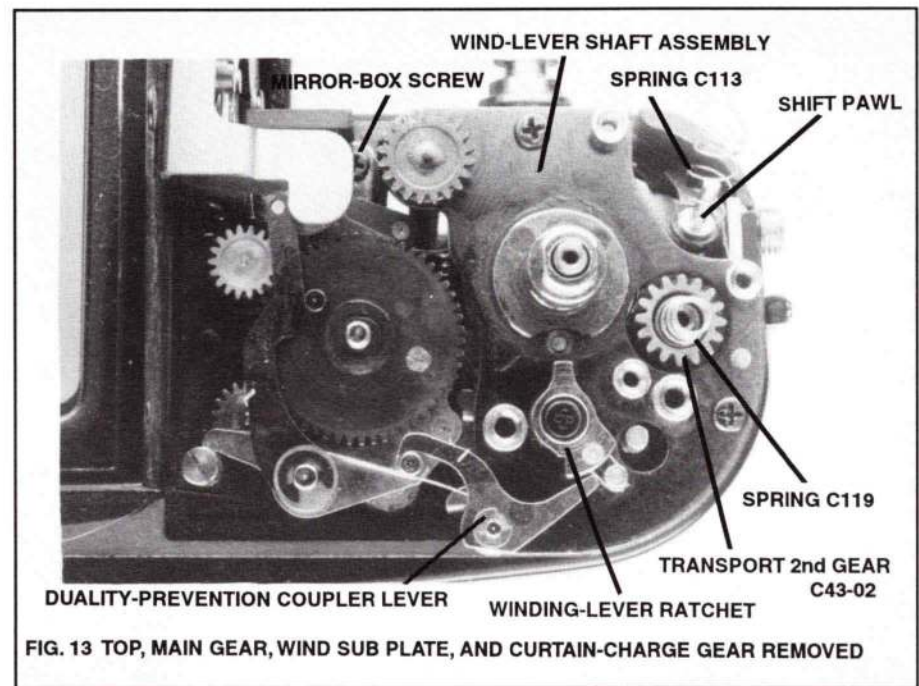

FIG. 13 TOP, MAIN GEAR, WIND SUB PLATE, AND CURTAIN-CHARGE GEAR REMOVED

lever shaft assembly, the replacement part comes with the spacer installed to hold the tension on the counter-return spring. Save the spacer for use as a special tool.

3. Hold in the reset actuator plate, and turn the film-metering roller, Fig. 3, to advance the counter dial past the "1" position. Advancing the wind lever should now charge the shutter and mirror. Release the

shutter by pushing down the release plate, Fig. 11.

4. For repeated shutter tests, you may prefer to remove the lever pawl, Fig. 12. The mirror and shutter will then operate—it's not necessary to wedge in the reset actuator plate.

#### Sequence to remove main gear:

1. scribe timing between main gear and mirror-charge 1st gear and

- between main gear and curtain-charge gear, Fig. 12
- 2. remove wind-lever stopper, Fig. 12 (2 screws)
- 3. remove lever pawl, Fig. 12 (retaining ring)
- 3. lift out main gear

**Note:** If you're replacing the winding-lever ratchet, remove the winding-lever-ratchet screw, Fig. 13; the spring may stay with the winding-lever ratchet.

On reassembly, seat the spring on the underside of the winding-lever ratchet; connect the spring ends to opposite sides of the post on the underside of the winding-lever ratchet. Then, as you install the winding-lever ratchet, connect the spring ends to the opposite sides of the post on the wind-lever shaft assembly, Fig. 13.

**Reassembly, main gear:**

1. Align the scribe lines on the main gear with the scribe lines on the mirror-charge 1st gear and on the curtain-charge gear, Fig. 12. If you're installing a new main gear (no scribe lines), turn the mirror-charge 1st gear and the curtain-charge gear clockwise—align the scribe marks with the main-gear position. Install the main gear in the position shown, Fig. 12. If you have no scribe lines for reference, time the main gear as follows:

- a. Turn the mirror-charge 1st gear, Fig. 12, clockwise to its stop—align the scribe on the mirror-charge 1st gear with the main-gear position, Fig. 12.
- b. Turn the curtain-charge gear, Fig. 12, fully clockwise (until it comes against the post on the 1st-curtain gear). Then back up the curtain-charge gear around 2 teeth.
- c. Replace the main gear as shown in Fig. 12. Replace the wind-lever stopper. Temporarily replace the wind lever to check operation.
- d. Since the lever pawl is removed, advancing the wind lever will charge the mirror and cock the shutter. Advance the wind lever fully until the winding-lever ratchet, Fig. 13, disengages from the main gear. Return the wind lever to the start position.

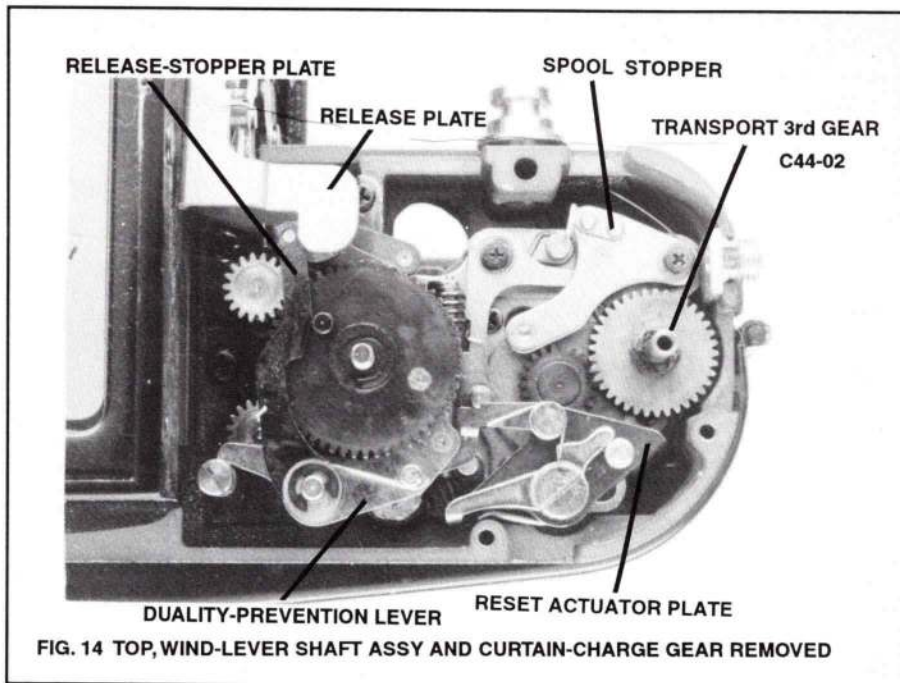

FIG. 14 TOP, WIND-LEVER SHAFT ASSY AND CURTAIN-CHARGE GEAR REMOVED

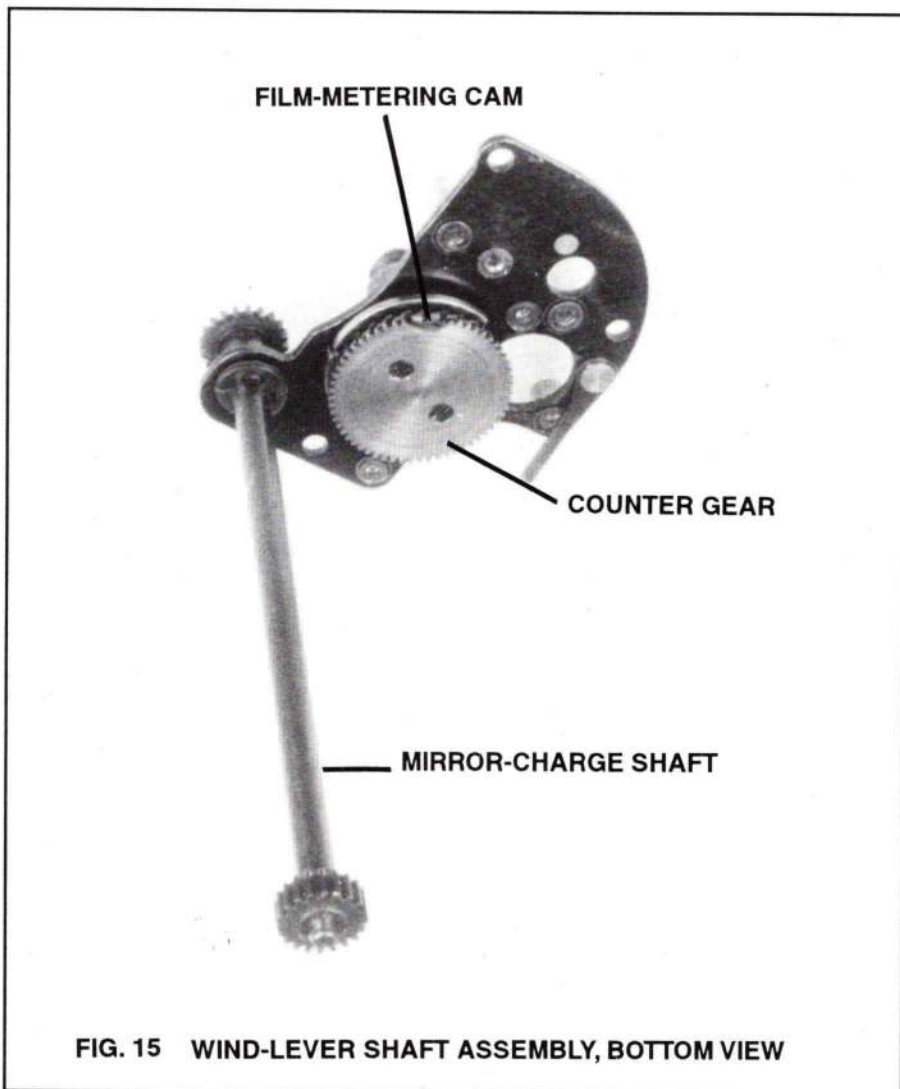

FIG. 15 WIND-LEVER SHAFT ASSEMBLY, BOTTOM VIEW

If you can't advance the wind lever far enough for the winding-lever ratchet to disengage, the overtravel is excessive—either the mirror mechanism or the shutter is stopping the wind lever.

**Caution:** Don't apply excessive force at the end of the wind cycle. If the shutter mechanism is stopping the wind lever, force could pull the curtains from the rollers.

To decrease the overtravel, lift the main gear and turn it 1 tooth counter-clockwise.

If the overtravel on the curtains is insufficient, the curtains will release together (2nd curtain not latching). Or the shutter may release as soon as you allow the wind lever to return (1st curtain not latching).

*To increase the overtravel on the shutter, loosen the nut holding the curtain-charge gear, Fig. 12. Lift the curtain-charge gear to disengage it from the main gear. Then turn the curtain-charge gear 1 tooth in a clockwise direction.*

If the overtravel on the mirror-charge mechanism is insufficient, the mirror mechanism won't latch. As a result, you can't release the shutter by pushing the release plate (release the curtains by disengaging the 2 curtain latches, Fig. 18, from the curtain gears).

*To increase the overtravel on the mirror-charge mechanism, lift the main gear to disengage it from the mirror-charge 1st gear. Turn the mirror-charge 1st gear 1 tooth in a clockwise direction.*

2. To replace the lever pawl, Fig. 12, locate the lower end of the shift-pawl spring C113, Fig. 13—the lower spring end hooks against the lever-pawl pin as shown in Fig. 17. Grasp the lower spring end and pull it toward the end of the camera (clockwise, as seen from the top). Hold the lower spring end as you seat the lever pawl. Pass the pin on the lever pawl through the slot at the top of the shift pawl, Fig. 11. Make sure the pin on the other end of the lever

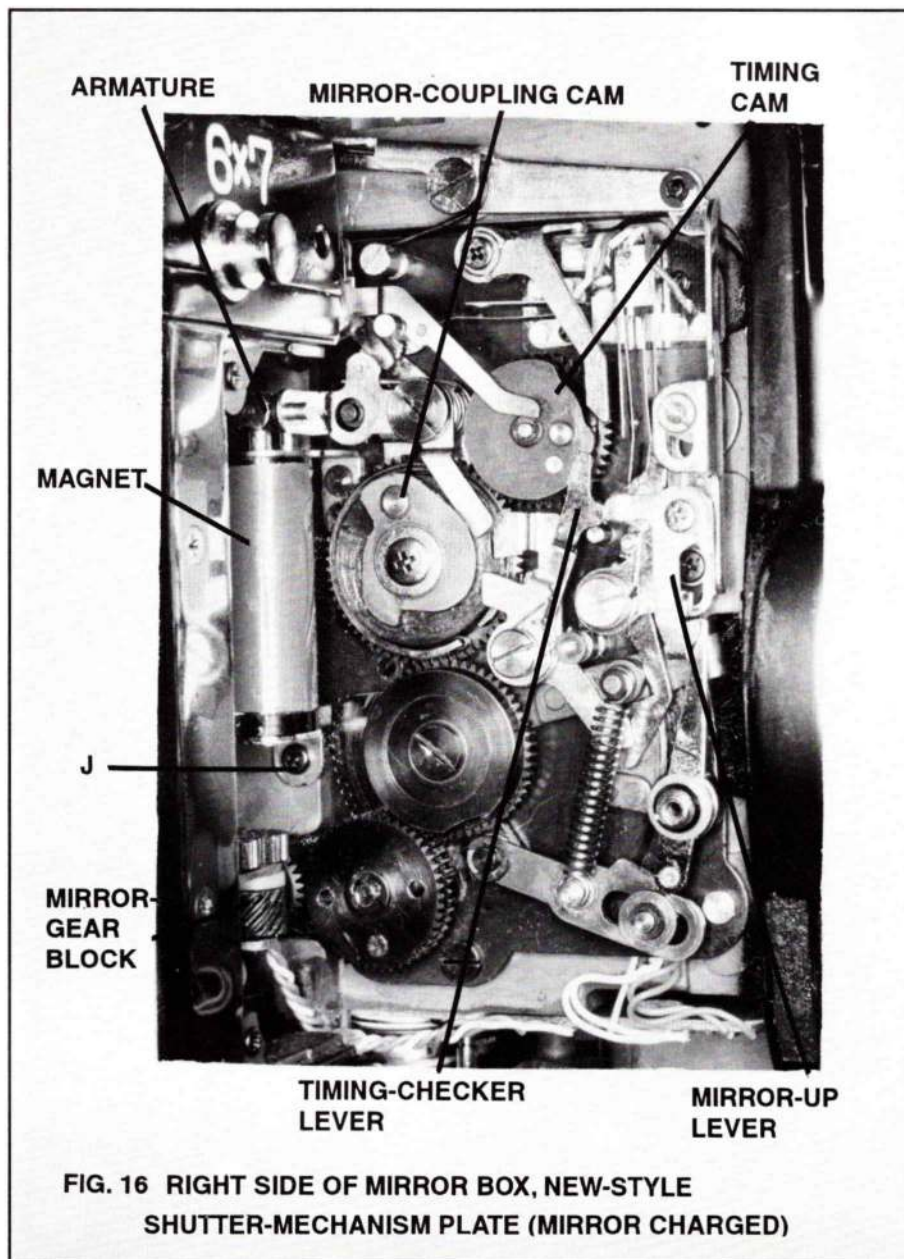

FIG. 16 RIGHT SIDE OF MIRROR BOX, NEW-STYLE SHUTTER-MECHANISM PLATE (MIRROR CHARGED)

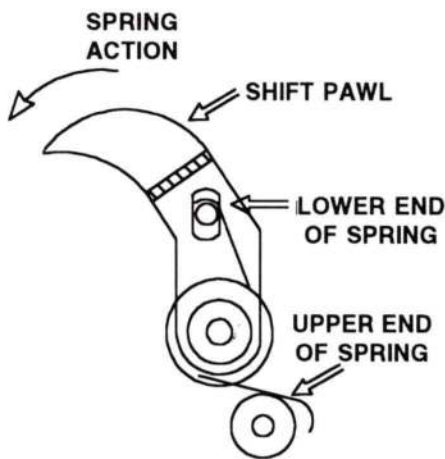

FIG. 17 SHIFT PAWL

pawl (underside) passes to the inside of the reset-coupler lever, Fig. 12.

**Sequence to remove wind-lever shaft assembly:**

1. remove main gear (previous sequence)
2. remove wind sub plate, Fig. 12 (4 countersunk screws)
3. lift out loose shift pawl, shift-pawl spring, and compression spring above transport 2nd gear, Fig. 13
4. remove duality-prevention coupler lever, Fig. 13 (E-clip—spring stays with duality-prevention coupler lever)
5. unscrew post screw for duality-prevention coupler lever

6. remove 2 remaining screws holding wind-lever shaft assembly, Fig. 13 (long screw to front also holds strap lug)
7. lift out wind-lever shaft assembly together with mirror-charge shaft, Fig. 15

**Reassembly, wind-lever shaft assembly:**

1. If you've lost the initial tension on the counter-return spring, tension the spring as follows:
  - a. Looking from the bottom of the wind-lever shaft assembly, Fig. 15, turn the counter gear clockwise to its stop—the post on the film-metering cam then comes against the post on the base plate.
  - b. Lift and turn the counter gear slightly clockwise until the post on the film-metering cam is on the other side of the post on the base plate—the post on the film-metering cam should be clockwise of the post on the base plate as seen from the bottom.
  - c. When you now turn the counter gear clockwise, the counter-return spring should return the assembly in a counterclockwise direction—until the post on the film-metering cam is against the post on the base plate.
  - d. Repeat the procedure to apply 2 more full turns of initial tension to the counter-return spring. The counter-return spring now has 2+ turns of initial tension. To prevent the film-metering cam from moving down and losing the initial tension, install the counter dial or the spacer, Fig. 11.

2. Seat the wind-lever shaft assembly, Fig. 13. Replace the 3 screws (including the post screw).

3. Seat the spring on top of the transport 2nd gear, Fig. 13 (smaller diameter coils up).

4. You can seat the shift pawl and shift-pawl spring as shown in Fig. 13—and then seat the wind sub plate. However, it may be difficult to locate the lower end of the shift-pawl spring—the spring end tends to

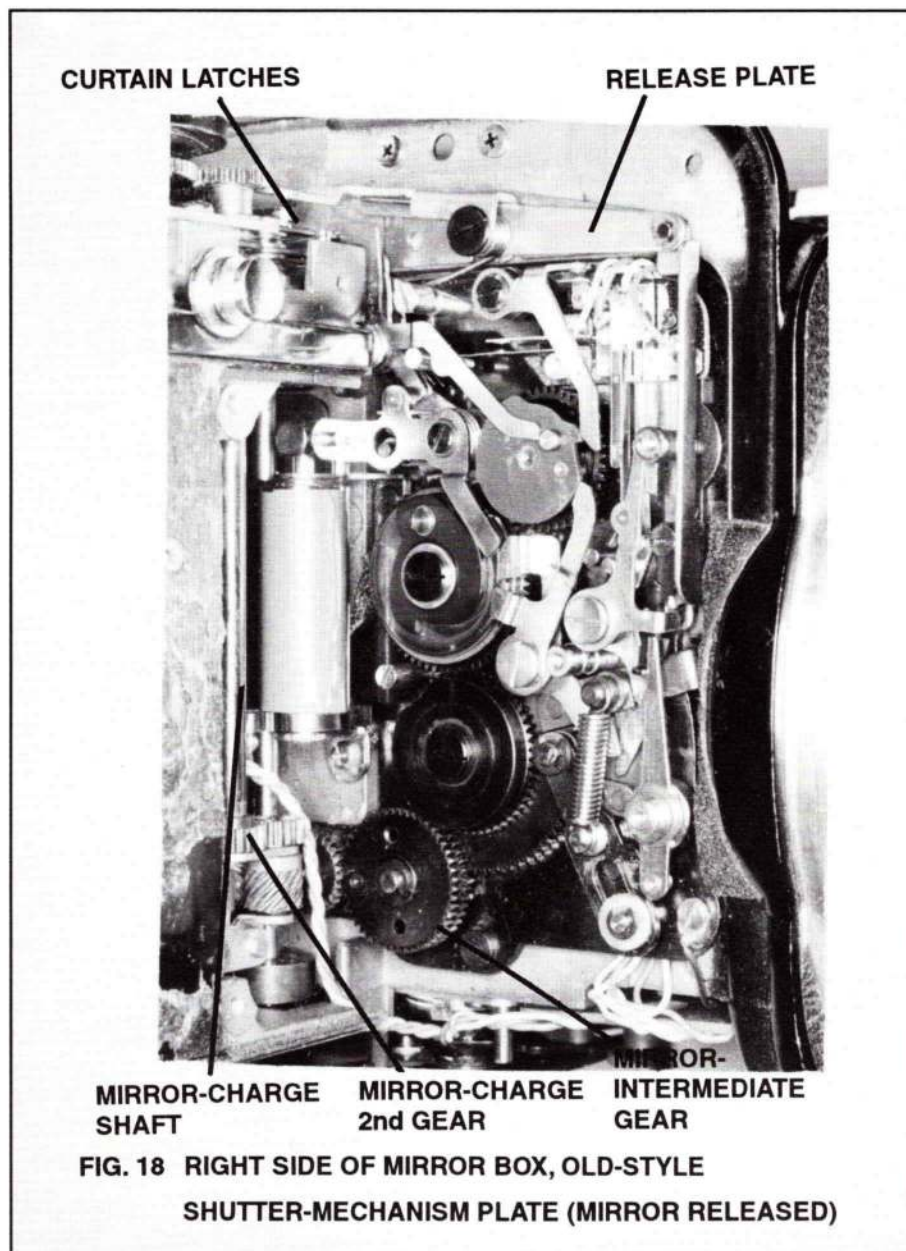

sneak underneath the base plate of the wind-lever shaft assembly. It's probably easier to assemble the shift pawl to the wind sub plate first; then install the parts as a unit. Procedure:

- a. Seat the shift-pawl spring over the shaft of the shift pawl.
- b. Seat the shift-pawl post in the bushing of the wind sub plate. Hold the shift pawl in position—against the pressure of the shift-pawl spring—as you seat the wind sub plate.

**Note:** To keep the lower end of the

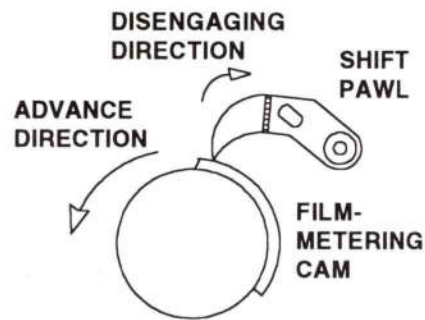

**FIG. 19 SHIFT PAWL BEING DISENGAGED BY FILM-METERING CAM**

shift-pawl spring in position, you can use a bent paper clip. Install the end of the paper clip through the hole in the wind sub plate and the slot of the shift pawl—the position of the pin on the lever pawl. Hook the lower end of the shift-pawl spring to the outside of the paper clip. Leave the paper clip in position until you're ready to replace the lever pawl. You'll then be able to reach the lower end of the shift-pawl spring.

c. Seat the wind sub plate by feeding the shift pawl into the cutout and alongside the film-metering cam. Make sure the end of the shift pawl passes to the outside edge of the film-metering cam, Fig. 19. Connect the upper end of the shift-pawl spring to the post on the wind-lever shaft assembly, Fig. 17, as you fully seat the wind sub plate. Replace the 4 countersunk screws holding the wind sub plate. With the wind sub plate installed, you should be able to push up the shift pawl—the shift-pawl spring should then push down the shift pawl.

5. The scribe line on the mirror-charge 1st gear may no longer be valid—the timing between the mirror-charge 2nd gear and the mirror-intermediate gear, Fig. 18, has been changed. Before you install the main gear, turn the mirror-charge 1st gear, Fig. 12, fully clockwise—the mirror-intermediate gear, Fig. 18, is then ready to pick up and charge the shutter-mechanism plate as soon as you start advancing the wind lever. Replace the main gear, aligning its other scribe line with the scribe on the curtain-charge gear. Then check timing as described earlier (*Adjustment Procedures* #10).

**Note:** You can now check for proper operation. However, with the wind-lever stopper removed, be careful to avoid overcharging the wind lever—advancing the shutter too far can pull the curtains from the rollers.

Temporarily seat the wind lever over the post on the main gear. Then advance the wind lever—stop advancing the wind lever as soon as the winding-lever ratchet disengages and swings clockwise. Return the

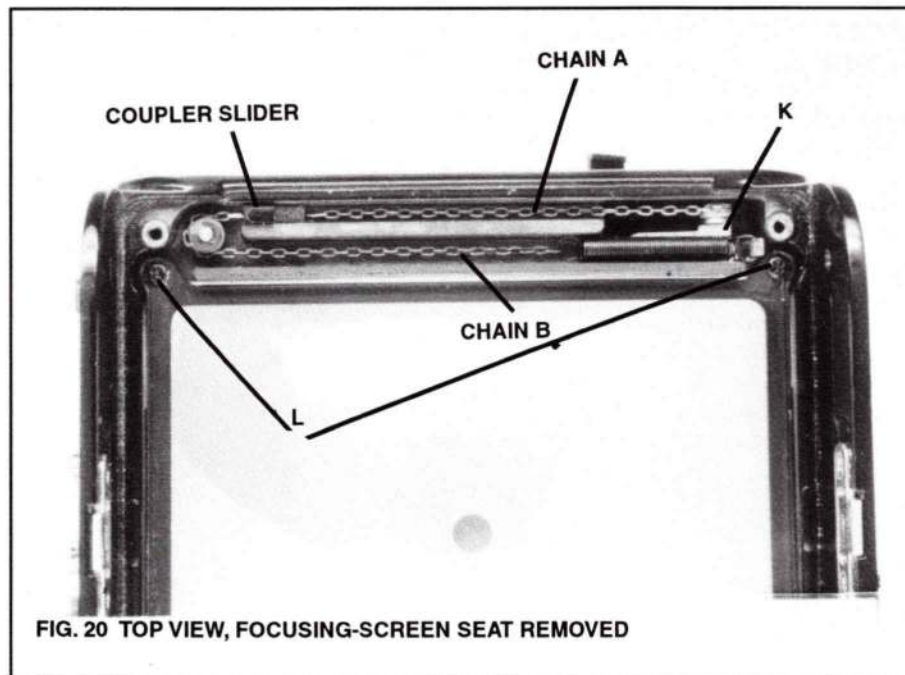

FIG. 20 TOP VIEW, FOCUSING-SCREEN SEAT REMOVED

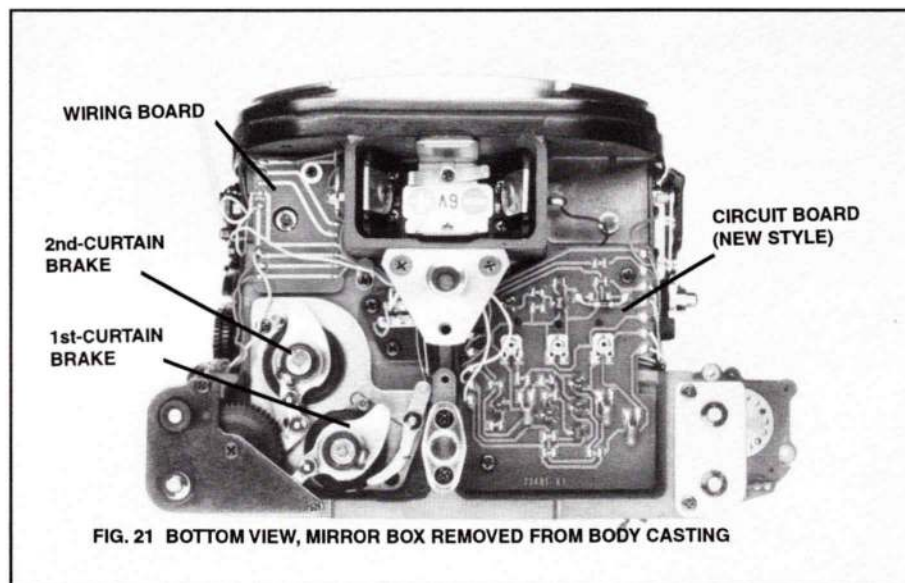

FIG. 21 BOTTOM VIEW, MIRROR BOX REMOVED FROM BODY CASTING

wind lever (and main gear) to the start position—the curtain-charge gear should then push the release-stopper plate, Fig. 14, toward the mirror box.

With the lever pawl removed, the curtains and mirror should charge—even without film in the camera. Release the shutter by pushing down the release plate, Fig. 14.

6. Replace the wind-lever stopper. Lock the threads of the two screws.

7. Replace the duality-prevention coupler lever, Fig. 13. Hook the spring for the duality-prevention

coupler lever to the back of the post on the duality-prevention lever.

8. To seat the lever pawl, hold the lower end of the shift-pawl spring toward the outside of the camera. Then pass the pin on the lever pawl through the slot in the shift pawl. With the lever pawl fully seated, allow the lower end of the shift-pawl spring to move against the lever-pawl pin, Fig. 17.

#### Sequence to replace meter chain:

1. remove viewfinder frame (plate above focusing screen, Fig. 2)—2

post screws at front, 2 small black screws at back

**Note:** Watch for spacer washers under the front corners of the viewfinder frame—the spacers are normally cemented in position.

Fig. 20 shows the route of the meter chain at the top of the camera. There are 2 chains: chain A connects between the coupler slider, Fig. 20, and the coupling ring, Fig. 1; chain B connects between the coupler slider and the spring, Fig. 20. If you're replacing chain B, you don't have to remove the coupling ring.

2. remove 4 leather sections, front corners of bayonet seat (lens-mounting ring)
3. remove bayonet seat (4 screws)

**Caution:** Watch for loose adjustment washers under corners of bayonet seat.

4. remove 2 coupling-ring covers, front of coupling ring (each held by 2 screws)
5. lift coupling ring to disconnect chain (the chain connects to a wire hook at the edge of the coupling ring)

#### Sequence to remove mirror-box/shutter assembly:

1. remove covers (it's not necessary to remove the left side cover)
2. remove wind-lever shaft assembly (*Sequence to remove wind-lever shaft assembly*)
3. remove finder-contact frame, Fig. 2—peel up 2 leather sections at back of finder-contact frame and remove 2 machine screws, remove 2 self-tapping screws from front of finder-contact frame (focusing-screen side)

**Note:** The plate with the finder contacts is now loose—it's held only by the 3 wires.

4. remove mirror-gear block, Fig. 16—2 screws (shoulder screw toward top)
5. lift out mirror-charge 5th gear (geared shaft between mirror-gear block and mirror-intermediate gear)—watch for a spacer washer

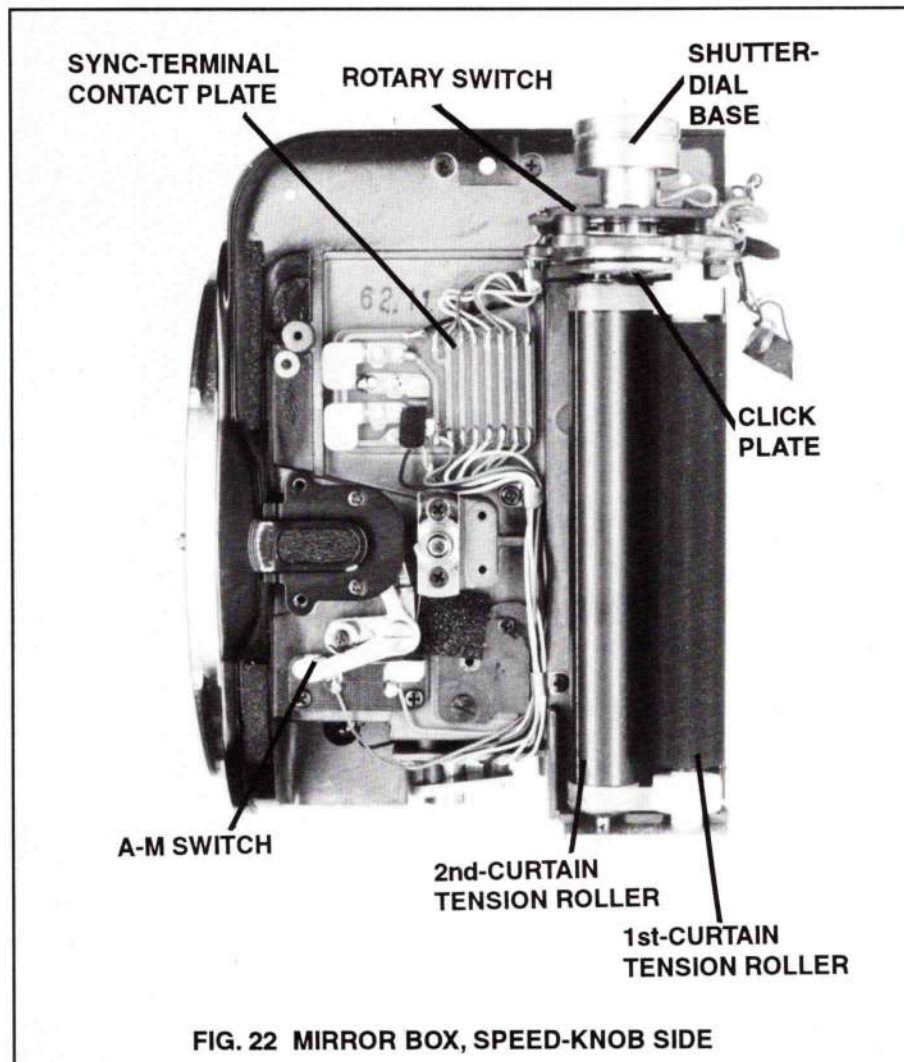

FIG. 22 MIRROR BOX, SPEED-KNOB SIDE

over the pivot end of the shaft (the pivot that goes into the mirror-gear block)

6. remove mirror-box screw at bottom of camera (in front of tripod socket, Fig. 4)
7. remove 2 mirror-box screws at top, speed-knob side (watch for a washer under the plate at the position of the screw toward the front of the camera)
8. remove 1 mirror-box screw at top, wind-lever side, Fig. 13 (watch for a washer under the plate at the screw position)
9. remove 5 mirror-box screws at the back of the camera—3 on top, 2 on bottom (the shoulder screw goes to the top at the speed-knob side)
10. remove the 2 porous-plastic light traps, 1 at each side of the mirror box (double-stick adhesive)

**Note:** Each L-shaped light trap sticks both to the body casting and to

the mirror box. You can leave the light traps on the body casting, Fig. 29. However, it's then necessary to hold the light traps out of the way as you install the mirror box.

11. lift out mirror-box/shutter assembly toward top of body casting, Fig. 22

#### Reassembly, mirror box:

1. Charge the curtains by turning the curtain-charge gear, Fig. 12, in a clockwise direction. With the curtains charged, you aren't as likely to catch the curtain tapes on the body casting.

2. Seat the mirror-box/shutter assembly from the top of the body casting. The armature on the magnet may tend to catch on the body casting during assembly. Push the spool-release coupler lever, Fig. 29, toward

the back of the camera as you fully seat the mirror box—the downward-projecting post on the reset-actuator lever, Fig. 24, must fit to the front of the spool-release coupler lever.

3. Before replacing the screws, seat the mirror 5th gear (shaft) on the side of the mirror box. With the assembly loose, you can shift the mirror box enough to install the mirror 5th gear.

4. Seat the mirror box fully. Replace the shoulder screw at the top back, speed-knob end. Then replace the remaining screws at the back and top.

5. Replace the spacer washer (if used) over the pivot of the mirror 5th gear. Then replace the mirror-gear block, Fig. 16. Fit the pivot of the 5th-gear shaft into the bearing hole on the underside of the mirror-bear block and replace the 2 screws (shoulder screw at top).

6. Check the coupling of the first-frame stabilizer, Fig. 29. With the shutter released, there should be a clearance of 0.2-0.5mm between the D-shaped stud of the stopper-release lever and the latching step of the first-frame stabilizer. When you close the back cover, the first-frame stabilizer should engage the stopper-release lever as shown in Fig. 14.

Disengage the first-frame stabilizer by pushing it toward the back of the camera (in normal operation, the duality prevention lever, Fig. 24, disengages the first-frame stabilizer at the completion of the shutter charge). As you then turn the curtain-charge gear to charge the shutter, the stud on the stopper-release lever should move within a range of 0.2~0.5mm as shown in the drawing below.

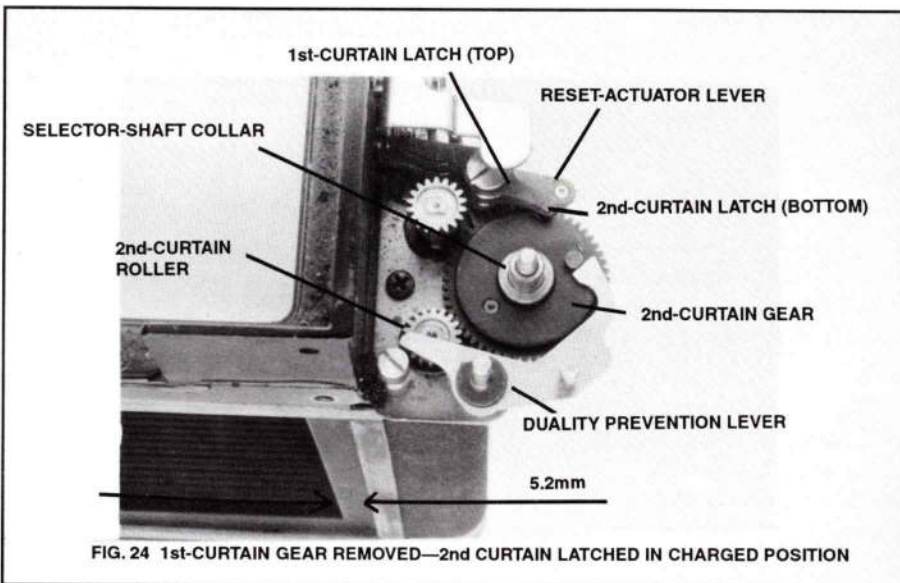
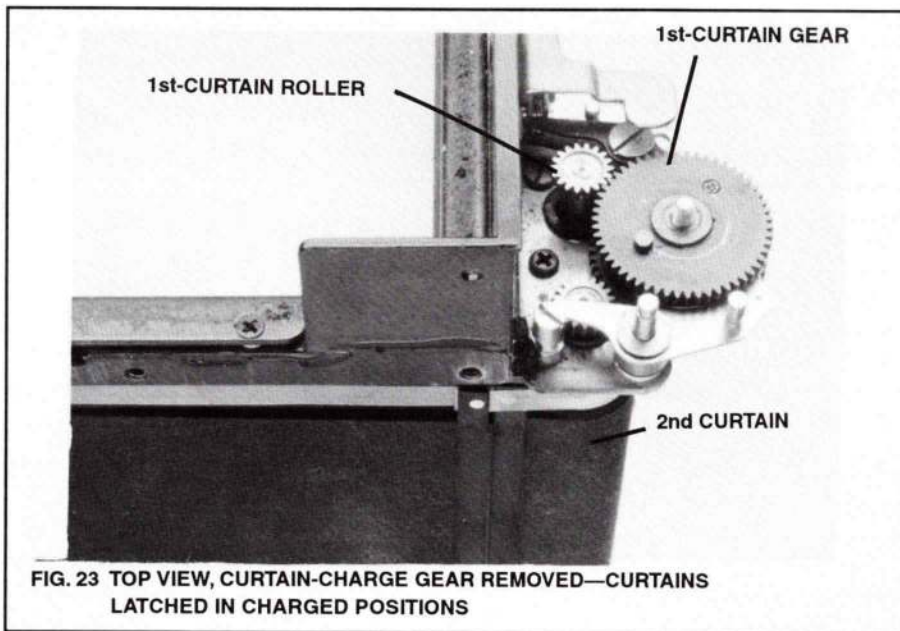
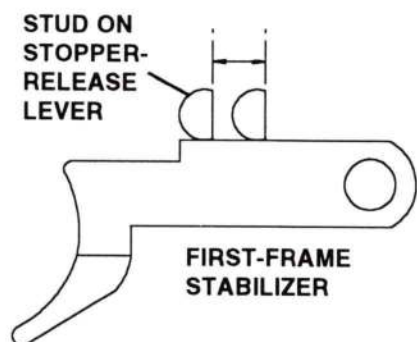

7. Replace the 2 porous-plastic light traps at the top of the body casting, one on each side of the mirror box.

8. Apply flat black lacquer to the joint between the back edge of the mirror box and the body casting to act as a light seal.

**Removing and timing curtain gears (mirror box removed):**

1. remove release-stopper plate, Fig. 14 (E-clip and washer—spring stays with release-stopper plate)
2. unscrew selector-shaft nut (nut holding curtain-charge gear, Fig. 12)
3. lift off curtain-charge gear, Fig. 12
4. scribe timing between 1st-curtain

- gear and 1st-curtain roller pinion, Fig. 23
5. lift off 1st-curtain gear and spacer, Fig. 23
6. lift off selector-shaft collar, Fig. 24
7. scribe timing between 2nd-curtain gear and 2nd-curtain roller pinion, Fig. 24
8. lift off 2nd-curtain gear, Fig. 24

**Reassembly, curtain timing:**

**Note:** If you scribed the curtain gears, you can use the scribe lines for retiming the curtains. Or you can time the gears by the curtain positions (described in the following

sequence). If you use the scribe lines for timing, check your timing by noting the curtain positions.

1. Turn the 2nd-curtain roller to wind on the 2nd curtain. Continue until the lead edge of the 2nd-curtain bar is 5.2mm behind the lead edge of the focal-plane aperture—aligned with the factory scribe, Fig. 24. Hold the curtain roller as you seat the 2nd-curtain gear in the latched position (held by the 2nd-curtain latch, Fig. 24). Check to make sure the 2nd curtain still aligns with the factory scribe. If not, change the timing between the 2nd-curtain gear and the 2nd-curtain pinion, Fig. 24.

2. Install the duality-prevention lever, Fig. 24 (if you removed it). Replace the selector-shaft collar.

3. Turn the 1st-curtain winding roller to wind on the 1st curtain. Position the 1st curtain for a 0.1mm overlap as shown in the drawing below.

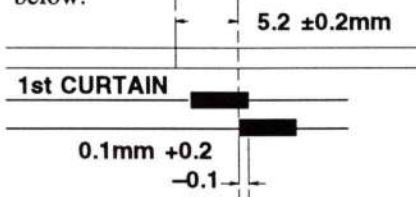

4. Hold the 1st-curtain roller and install the 1st-curtain gear in the latched position. Both curtains should now be charged, held by their latches. Check the position of the 1st curtain. If it isn't correct, change the timing between the 1st-curtain gear and the 1st-curtain pinion.

5. Seat the spacer on top of the 1st-curtain gear, Fig. 23. Then replace the curtain-charge gear with the selector-shaft nut, Fig. 12.

6. Disengage the 1st-curtain latch, Fig. 24, to release the 1st curtain. Disengage the 2nd-curtain latch, Fig. 24, to release the 2nd curtain. Charge the curtains by turning the curtain-charge gear in a clockwise direction—stop during the curtain-charge gear as soon as the curtain latches drop into engagement with the curtain gears. (turning the curtain-charge gear too far could pull the curtains from the rollers).

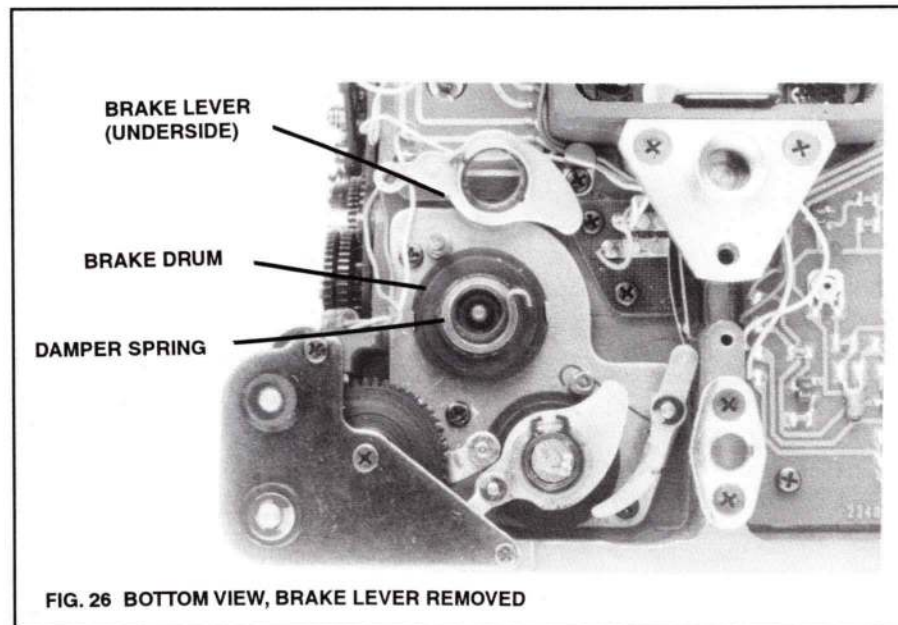
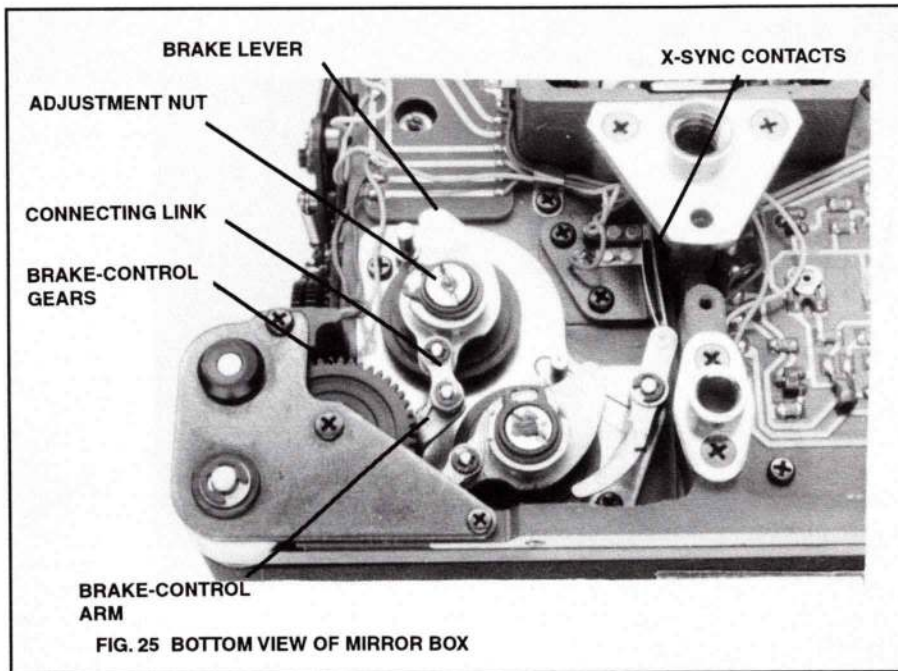

7. Replace the release-stopper plate, Fig. 14. Hook the spring for the release-stopper plate to the back of the post on the duality-prevention lever.

**Sequence to remove curtain latches: (curtain gears don't have to be removed):**

**Note:** You can remove the curtain latches without removing the mirror box or the curtain gears. If the mirror box is still installed, remove the release plate, Fig. 14 (E-clip at end,

large screw and spring)

1. remove screw holding curtain latches, Fig. 24
2. lift out 1st-curtain latch, Fig. 24
3. lift out brass shoulder bushing with spring
4. lift out 2nd-curtain latch
5. lift out brass shoulder bushing with spring

**Note:** The reset-actuator lever, Fig. 24, fits over a shoulder on the base plate. With the curtain latches removed, the reset-actuator lever

tends to move off the shoulder. There's usually a spacer washer under the reset-actuator lever.

### Reassembly:

1. Both brass shoulder bushings and both curtain latches are the same. Just make sure the curtain latches are right side up, Fig. 24.

2. Seat the bushing for the 2nd-curtain latch on top of the reset-actuator lever, Fig. 24. Hook the spring to the front of the post on the curtain plate.

3. Seat the 2nd-curtain latch, Fig. 24. Pass the hooked end of the spring under the 2nd-curtain latch—hook the spring to the back edge of the 2nd-curtain latch as shown in Fig. 24.

4. Seat the bushing for the 1st-curtain latch on top of the 2nd-curtain latch. Replace the 1st-curtain latch and the screw, Fig. 24. Before tightening the screw, make sure the reset-actuator lever, Fig. 24, moves freely. It may be necessary to shift the reset actuator lever until it fits over its shoulder without binding.

5. Pass the hooked end of the spring under the 1st-curtain latch; connect the hooked end to the back edge of the 1st-curtain latch, Fig. 24.

### Sequence to disassemble curtain brakes:

**Note:** You can replace the damper spring, Fig. 28, without disturbing the adjustment—avoid turning the setscrew at the top of the adjustment nut, Fig. 25. Be sure to note and replace washers above and below the compression brake spring, Fig. 28.

The illustrations show the disassembly of the 2nd-curtain brake. However, the procedure is the same for both brakes.

1. remove mirror box from body casting
2. remove E-clip and washer from end of connecting link that couples to brake-control arm, Fig. 25

**Note:** The connecting link, Fig. 25,

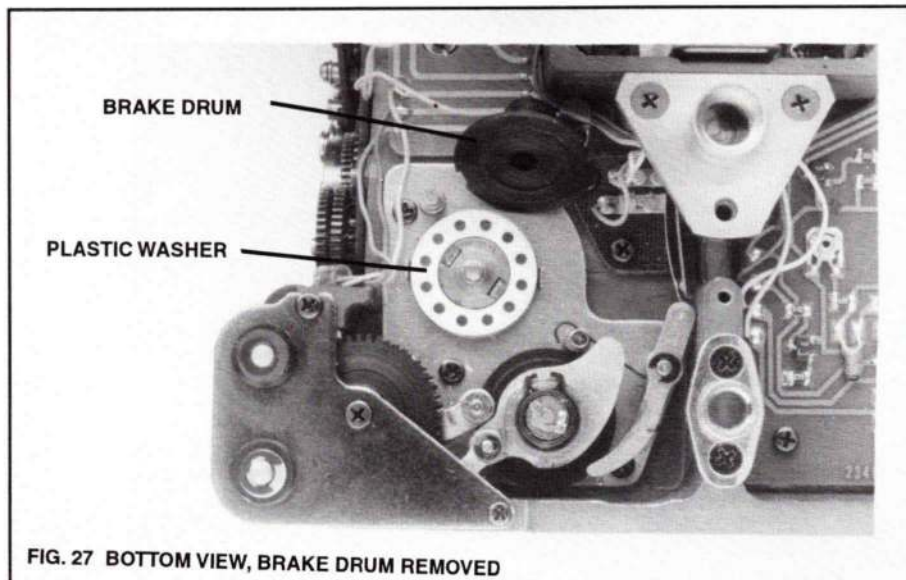

connects the brake lever to the brake-control arm. Each curtain gears to its own brake-control gear, Fig. 25. When a curtain crosses the aperture, its brake-control gear drives the brake lever in a counterclockwise direction, Fig. 25—against the pressure applied by the brake spring.

A torsion-type spring at the top of the brake lever hooks to the post for the connecting link. Disconnect the end of the connecting link that couples to the brake-control arm (rather than the end that couples to the brake lever). The end of the torsion-type spring then stays in place.

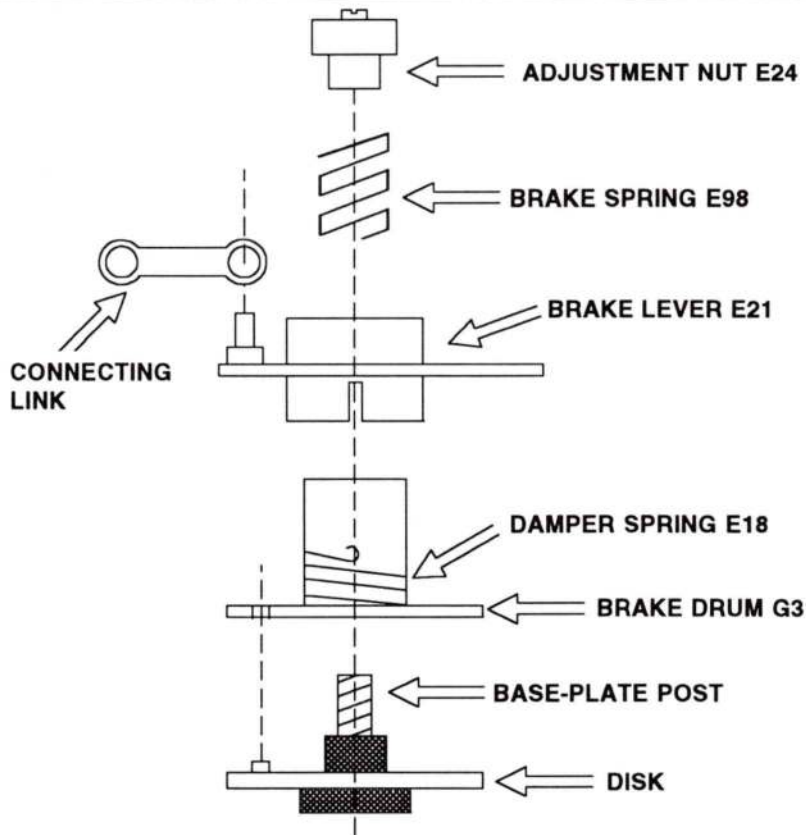

FIG. 28 BRAKE ASSEMBLY

3. unscrew adjustment nut, Fig. 25—left-hand thread
4. lift out compression brake spring, Fig. 28—note washers at each end of brake spring
5. remove snap ring holding brake lever—there may be an adjustment washer under the snap ring
6. lift out brake lever, Fig. 26
7. lift out brake drum, Fig. 27
8. remove brake-damper spring E18 from brake drum, Fig. 28—there may be an adjustment washer under the damper spring

**Note:** There are white plastic washers, Fig. 27, on each side of the disk, Fig. 28. There may also be an additional metal washer and a third plastic washer above the disk.

### Reassembly, brakes:

1. Seat the damper spring over the brake drum as shown in Fig. 26 and Fig. 28 (hooked end up).
2. Seat the brake drum with its 2 slots passing over the tabs on the disk, Fig. 28.
3. Seat the brake lever with its slot passing over the end of the damper spring, Fig. 28. Replace the snap ring.
4. Replace the brake spring (washer at each end) and screw down the adjustment nut, Fig. 28.
5. Connect the connecting link to the post on the brake-control arm, Fig. 25. Replace the washer and E-clip. Check for curtain bounce after you replace the mirror box in the body casting.

### Other disassembly notes:

1. **Counter 1st gear.** Hold the film-metering roller, Fig. 2. Then unscrew the counter 1st gear, Fig. 29 (normal thread). Watch for a washer around the shaft of the counter 1st gear.
2. **Shutter-mechanism plate**  
Pentax supplies the shutter-mechanism plate, Fig. 30, as a complete unit. You can also get individual parts for the shutter-mechanism plate. Remove the mirror box from the body casting. Then:

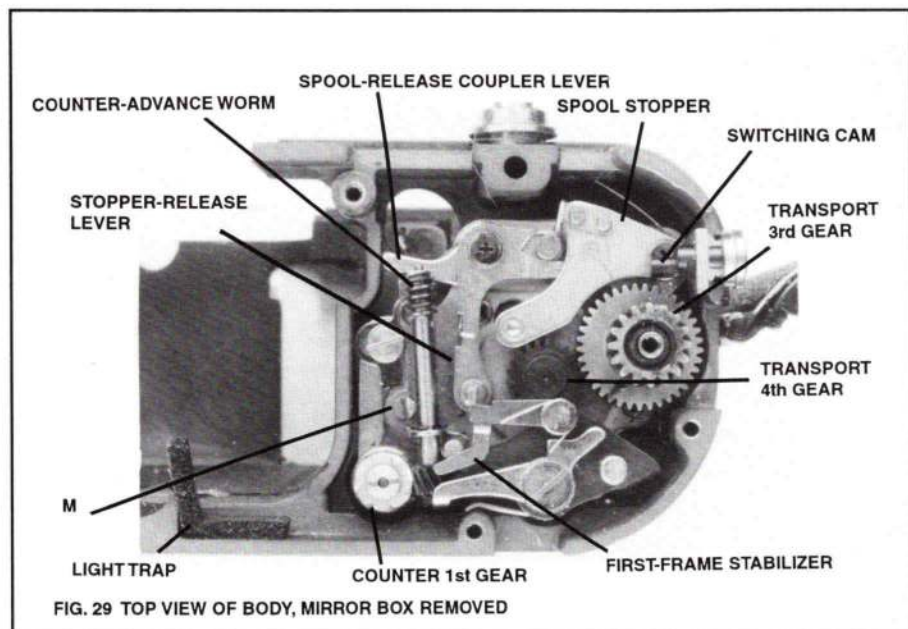

- a. remove mirror damper and spring from inside mirror box, wind-lever side (hold open shutter and reach from back)
- b. remove release plate, Fig. 30 (E-clip, screw with spring)
- c. unsolder wires from main-switch assembly, Fig. 30 (see Fig. 36 for wiring diagram)
- d. remove 4 screws holding shutter-mechanism plate—post screw in upper left-hand corner (spring-hooking post for release-plate spring), shoulder screw that passes through slot in release-coupler plate, minus-head screw in lower right-hand corner, minus-head screw at bottom
- e. lift out shutter-mechanism plate—tilt the shutter-mechanism plate until the diaphragm-closing lever clears the camera-body slot.

3. **Rotary switch.** Remove the left-side top cover, Fig. 1. Set the shutter-dial base (brass shaft, Fig. 22) to bulb—the notch in the shutter-dial base then faces the front of the camera. Remove the shutter-dial base by unscrewing the nut (top). Fig. 34 shows the wiring to the rotary switch. On reassembly, make sure the click plate, Fig. 22, is still on the bulb hole. Turn the movable contact of the rotary switch until it centers on the bulb contact, Fig. 33. Replace the shutter-dial base with its downward-projecting tab facing the front of the camera.

### REVISED SECTIONS

Since the Pentax 6x7 has been in production over 20 years, there have been many modifications. The following revisions may affect your repairs:

1. There are two versions of the camera—the original version (product #23400) and the current version (product #23401). Parts are no longer available for the original product. But in many cases, you can install the new-style parts to update the camera. Both versions provide 10 exposures on 120 film. The original version gives 21 exposures on 220 film, while the current version gives 20 exposures on 220 film. The original version does not have the mirror lock-up feature. Other ways to identify the different products:
  - The original version has metal side covers and a metal bottom cover (plastic in the current version).
  - The original version has a rubberized film-metering roller, Fig. 3 (metal in the current version).
  - In the original version, the end of the right top cover is marked 21-10 next to the 120/220 selector (for 21 exposures or 10 exposures). The calibrations on the current version are 220-120.

2. **Film-metering cam,** Fig. 15.  
Pentax revised the film-metering cam

to provide the change from 21 exposures to 20 exposures. If you replace the wind-lever shaft assembly, Fig. 15, in an old-style camera, also replace the counter dial C105 (the old style has a "21" calibration). Explain to the customer that the camera now provides 20 exposures on 220 film rather than 24 exposures.

**3. Shutter-mechanism plate,** Fig. 30 (mirror-operating mechanism at side of mirror box). Revised to provide the mirror-up feature. Fig. 16 shows the current style; Fig. 18 shows the early style that doesn't have the mirror-up lever. If you're replacing the shutter-mechanism plate in an original version, also replace the right side cover, Fig. 2. You've then updated the camera to add the mirror lock-up feature.

**4. Main gear,** Fig. 12. The current production camera may also have the old-style main gear. You can identify the style by the number of ratchet teeth on the underside of the main gear; the winding-lever ratchet, Fig. 13, rides against the ratchet teeth. The old-style main gear has 16 ratchet teeth; the new-style main gear has 10 ratchet teeth. Only the new style is supplied. If you're replacing the main gear in a camera that has the old style, also replace the winding-lever ratchet, Fig. 13. The winding-lever ratchet has been revised for the new-style main gear.

**5. Circuit board,** Fig. 4. The old style, Fig. 4, is brown; the new style, Fig. 21, is green. The position of the slow-speed and battery-check adjustments are reversed in the two boards. Fig. 6 shows the adjustments on both boards. Interchangeable.

The new-style circuit board uses surface-mount transistors and resistors. The wiring is the same. But in the old-style board, the wires pass through holes in the underside of the board. In the new-style board, the wires connect to solder lands at the top of the board. The difference in the circuit is the connection of C2, Fig. 31—in the new-style board, C2 connects to the TR1 emitter.

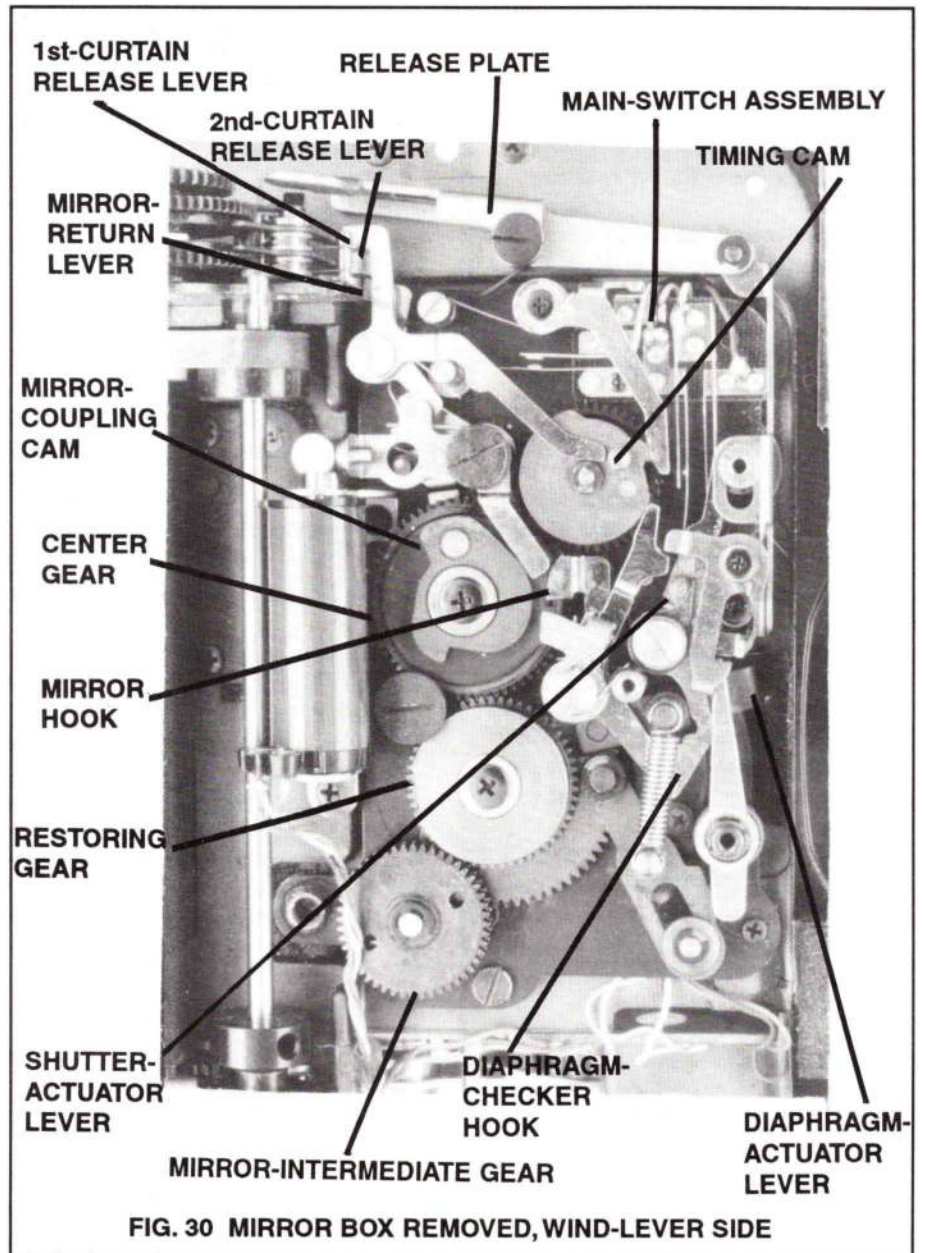

FIG. 30 MIRROR BOX REMOVED, WIND-LEVER SIDE

**6. Spring for counter-transport button.** The old style is a flat spring—the counter-transport button fits in the hole on top of the spring, Fig. 9. The new-style spring is a coil spring. Only the new style is supplied—C132-01.

**7. Main-switch assembly,** Fig. 30. The new style has thicker, gold-plated contacts.

**8. Multiple-exposure feature.** The multiple-exposure mechanism (not illustrated) disengages the film transport. Advancing the wind lever then charges the mirror without

advancing the film.

Pentax provides parts to modify the camera for intentional multiple exposures. The modification requires replacing the right top cover and adding parts to disengage the transport. The new-style camera body has a cutout at the end that provides clearance for the added parts. The old-style camera body has no cutout; it's then necessary to file a cutout.

Making the modification with the old-style body may not be practical (although Pentax will make the modification with either style body).

Since the parts are expensive (over \$100 for all the parts), it may be more economical to have Pentax make the modification—the charge isn't much more than you pay for the parts. The parts for the revision are supplied individually, not as a kit. The following list shows the parts required for the modification:

- C22-50
- C207-50
- C209-50
- C211-50
- 0-C206-50
- C204-50
- 0-C210-50 (top cover)
- C203-50
- C201-50
- C202-50
- CNL D1.4x2.2 (screw)
- CNS 1.7x5.0 (screw)
- C208-50 (locking pin)

The locking pin C208-50 that holds the multiple-exposure lever in the normal or multiple setting comes in 3 diameters—A, B, and C. The difference is the diameter of the end that engages the multiple-exposure lever (C is the largest size). If you're making the modification, you may need all 3 sizes to assure that the multiple-exposure lever latches positively at both settings.

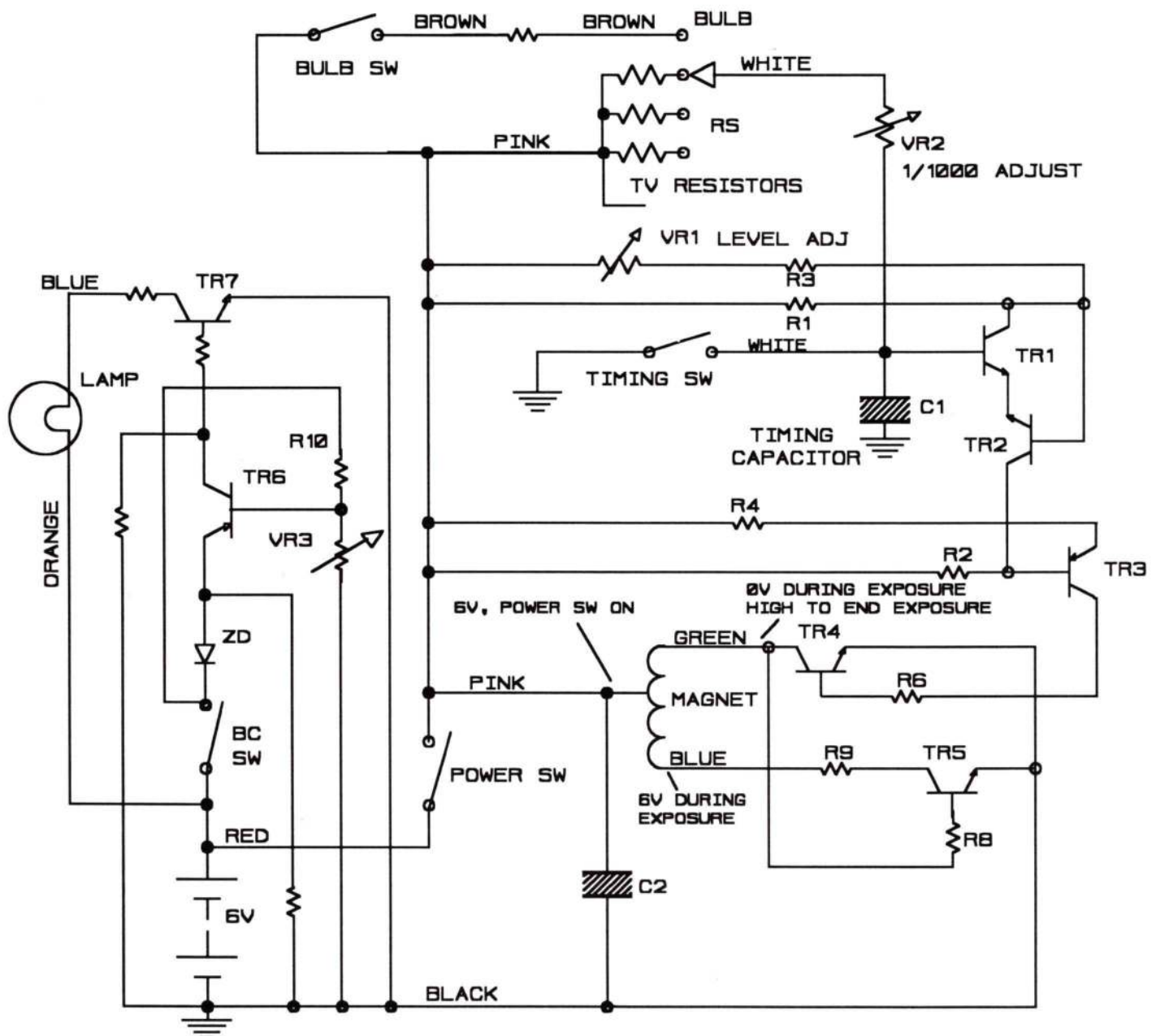

FIG. 31 SCHEMATIC

# TROUBLESHOOTING

**Behavior without battery:** mirror locks up (moves part way up). To free the mirror, push the mirror-release button (front, release-button side of lens)—the mirror should move up fully. Then push the release button to release the shutter.

**Behavior without film or with back cover open:** advancing the wind lever turns the spool, but does not charge the mirror and shutter

## Current draw:

leakage—under  $2\mu$ a  
shutter open—around 25ma

## Frequently repaired sections:

**Note:** Most of the repairs in the 6x7 are mechanical—circuit repairs are normally limited to the switches. The circuit, Fig. 31, is a basic analog timing circuit. When the timing switch opens, the timing capacitor C1 charges through the TV (RS) resistance selected by the speed knob. The circuit then shuts off the current through the magnet. The magnet releases its armature to disengage the 2nd curtain.

1. **Curtain bounce** because of broken damper spring. With 1st-curtain bounce, you can normally see the 1st curtain re-enter the aperture (check at a slow speed). With 2nd-curtain bounce, you can see a slit of light at the closing side of the aperture (check at the X setting and 1/1000).

**Disassembly required:** Remove mirror-box/shutter assembly from body shell.

2. **Wind slips** because of worn main gear. Or the **wind lever fails to latch** after the film advance because of a worn winding-lever ratchet.

**Disassembly required:** Right-side top cover, main gear.

3. **Shutter hangs open** because of dirty RS-resistor contacts on rotary switch, Fig. 33.

**Disassembly required:** Left-side top cover.

4. **Mirror locks up** with good battery because of poor contact in power switch, Fig. 32.

**Disassembly required:** Right side cover.

## 5. Meter-coupling chain broken.

**Disassembly required:** Lens-mounting ring, focusing-screen frame.

6. **Overlapping film frames** because of bent shaft on counter 1st gear, Fig. 29.

**Disassembly required:** Remove mirror-box/shutter assembly from body shell.

## Troubleshooting steps:

1. Shutter hangs open

### RS-resistor contacts

Clean the RS-resistor contacts and wiper, Fig. 33. Check the RS resistors by measuring the resistance between the pink and white wires to the rotary switch, Fig. 33. Approximate resistances:

1/1000—800 $\Omega$
1/500—1.7K
1/250—3.2K
1/125—6.4K
1/60—12.5K
1/30—25K
1/15—50K
1/8—100K
1/4—198K
1/2—395K
1—790K
X—26.5K
Bulb—1K

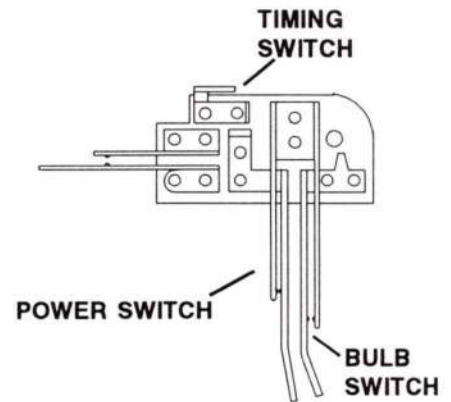

**FIG. 32 MAIN-SWITCH ASSEMBLY, RELEASE SIDE OF MIRROR BOX**

### Power switch, chattering

Clean the power switch and reform the contacts for better pressure, Fig. 32. The power switch may be making adequate contact to release the shutter. However, if the contact isn't firm, contact bounce may prevent the shutter from timing out.

### Timing switch

Check for a constantly closed timing switch, Fig. 32. The timing switch should be open (white wire to ground) with the mirror charged.

### Timing capacitor C1, circuit board

C1, Fig. 35, should charge after the release (when the timing switch opens). You can check at the white wire to the RS resistors, Fig. 33. When you release the shutter, the voltage at the white wire should

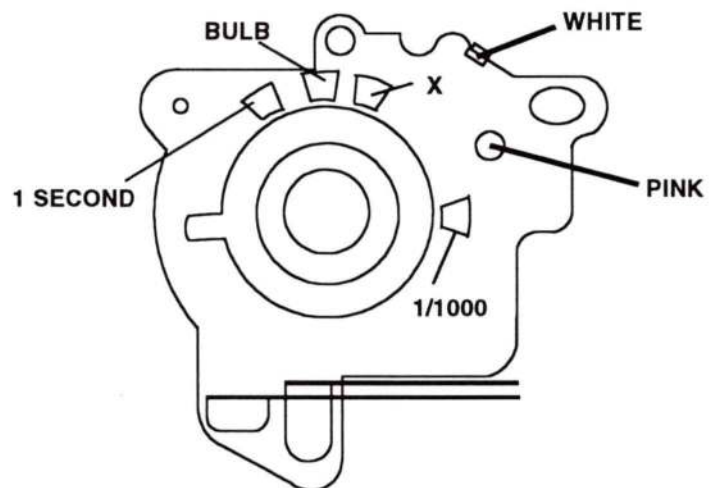

**FIG. 33 ROTARY SWITCH, TOP REWIND END**

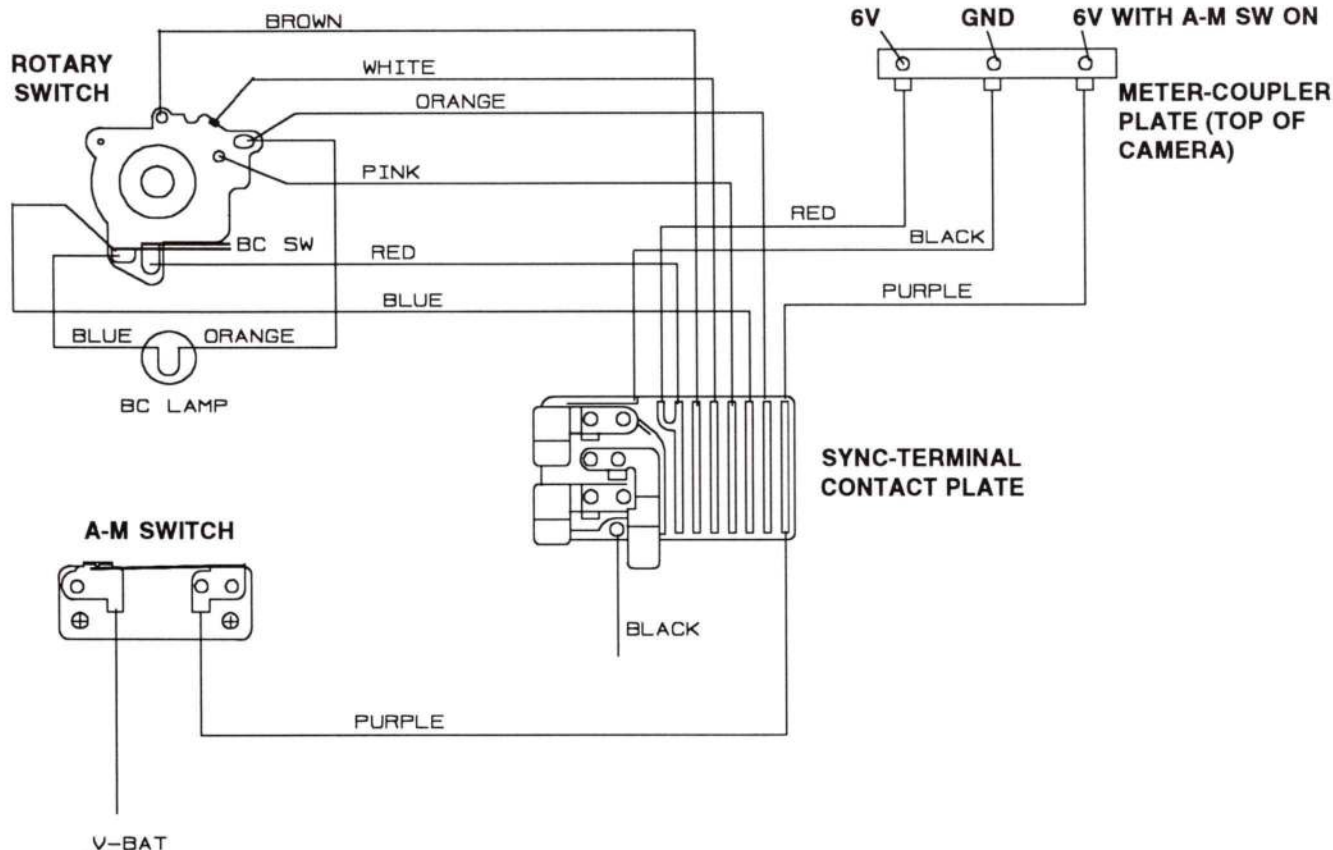

**FIG. 34 WIRING, TOP TO REWIND SIDE OF MIRROR BOX**

increase as C1 charges. When the voltage reaches around 1.8V, the shutter should close.

*Voltage at white wire doesn't increase or fails to reach 1.8V*—the timing capacitor C1 may be defective. Also check the voltage at the pink wire to the RS resistors—the voltage should switch to 6V when you release the shutter. If not, check the pink-wire solder connections at the RS resistor, at the circuit board, and at the sync-terminal contact plate, Fig. 34.

*Voltage at white wire does reach 1.8V, but shutter won't close*—circuit board defective.

2. Mirror locks up (moves part way, shutter won't release)

#### **Battery, battery connections**

Check for 6V at the red wire to the power switch, Fig. 36. No voltage—red-wire solder connections, battery connection to wiring board at bottom

of camera, Fig. 36.

#### **Power switch**

Clean the power switch, Fig. 36, and improve the switch contact. Check the voltage to the pink power-switch wire when you release the shutter—the pink wire should switch to 6V.

#### **Magnet**

Clean the armature/core interface. Check the magnet coils at the pink, green, and blue leads, Fig. 36.

pink to blue—165Ω  
pink to green—270Ω  
blue to green—435Ω

#### **Circuit board**

The circuit board may not be providing power to the magnet. Check the voltages at the pink, green, and blue magnet leads, Fig. 36.

Pink or blue to ground—6V when you release the shutter.  
Green to ground—0V during

exposure, switches high to end exposure.

3. Shutter won't close at bulb

#### **Bulb switch**

Check for poor contact, Fig. 36.

#### **Power switch**

Clean and reform the power switch, Fig. 36, for better contact. The contact may be sufficient for the shutter release, but not sufficient for the timing capacitor to charge at bulb.

#### **RS contact**

Check for poor contact between the wiper and bulb contact, Fig. 33.

#### **Circuit board**

The bulb reesistor R12 (1K) may be open or have poor solder, Fig. 4. Check for 1K at bulb between the pink and white wires of the rotary switch, Fig. 33.

4. Shutter won't stay open at bulb

**Bulb switch**

The bulb switch, Fig. 36, should open when you release the shutter. Check for a shorted switch, insufficient space gap.

5. Shutter runs through without opening

**Wind overtravel**

Watch the curtain latches, Fig. 24, as you advance the wind lever. At the end of the wind stroke, you should see both latches drop into engagement with their respective curtain gears. If the latches don't engage, it may be necessary to increase the shutter overtravel by changing the timing between the curtain-charge gear and the main gear.

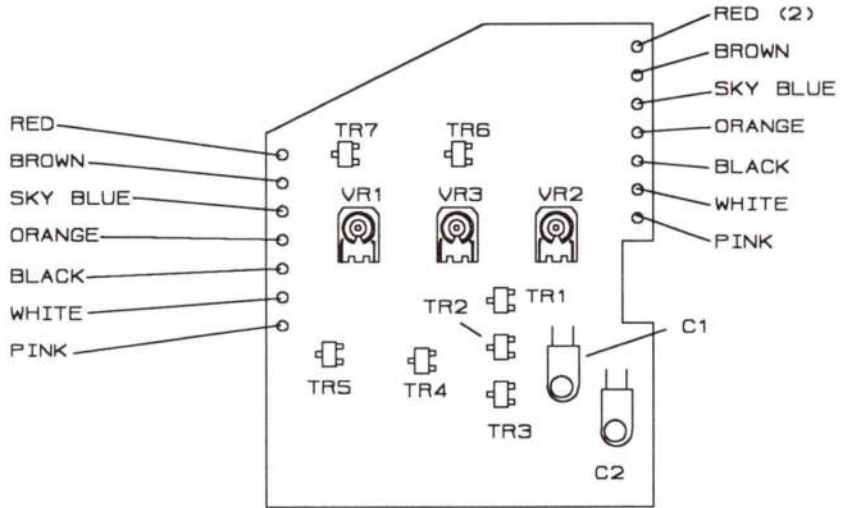

**FIG. 35 NEW-STYLE CIRCUIT BOARD**

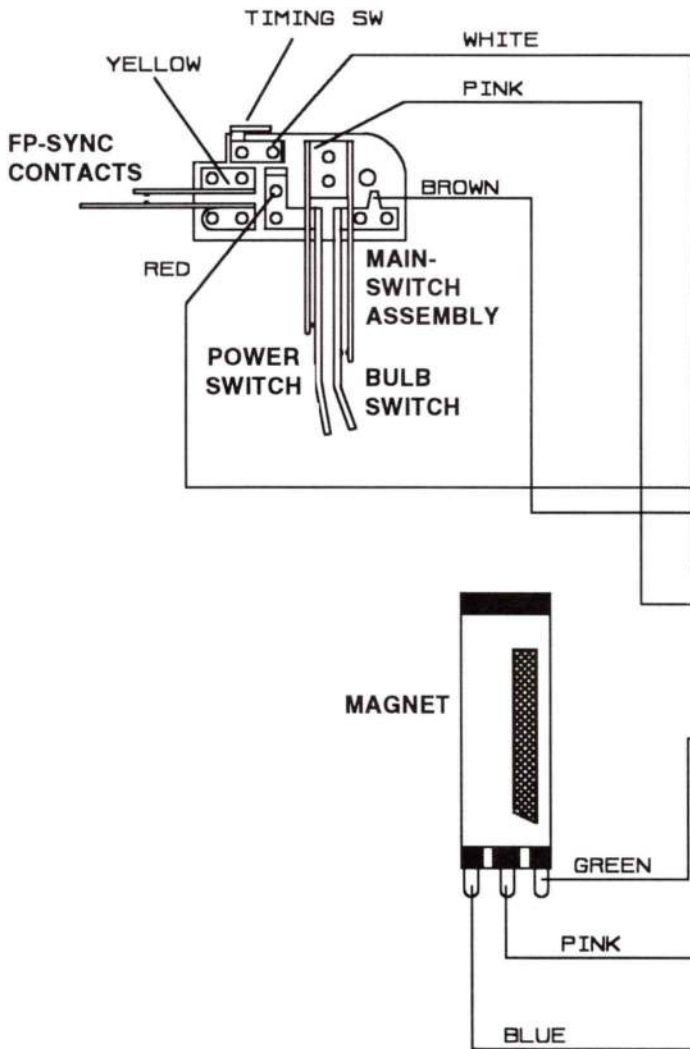

**FIG. 36 WIRING, RELEASE SIDE OF MIRROR BOX TO BOTTOM OF CAMERA**

**2nd-curtain latch**

Check the 2nd-curtain latch, Fig. 24, for free movement, disconnected or broken spring, burr on latching end. Also check for a bent 2nd-curtain latch. If the 2nd-curtain latch is bent up slightly, it may bind against the geared section of the 2nd-curtain gear.

6. 1st curtain releases when wind lever returns

**Wind overtravel**

Check the overtravel on the shutter curtains (*Adjustment Procedures #10*).

**1st-curtain latch**

Check for a bind or a burr that may be preventing the 1st-curtain latch, Fig. 24, from engaging the 1st-curtain wind gear.

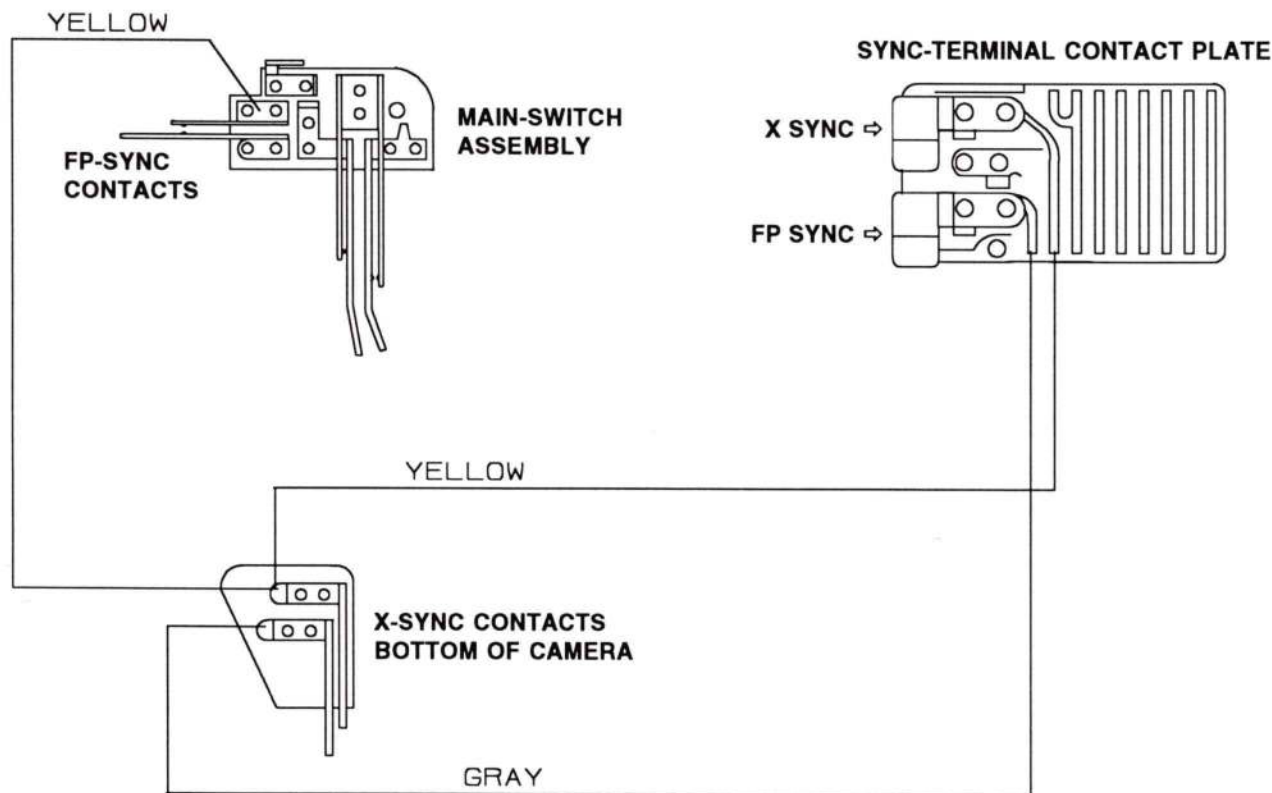

**FIG. 37 WIRING, SYNC CONTACTS**

**Shutter-mechanism plate**

At the completion of the wind cycle, the timing-checker lever should latch the timing cam as shown in Fig. 16. If not, check the timing-checker lever for a bind, broken spring.

7. Wind lever doesn't latch after advancing film

**Winding-lever ratchet**

Check the end of the winding-lever ratchet, Fig. 13, for wear.

**Duality-prevention coupler lever**

At the end of the wind stroke, the duality-prevention coupler lever should latch the winding-lever ratchet, Fig. 13; the duality-prevention lever then holds the winding-lever ratchet in position to block the main gear. The 2nd curtain disengages the duality-prevention coupler lever when it ends the exposure. Check the end of the duality-prevention lever (the end that engages the winding-lever ratchet) for wear.

8. Wind doesn't disengage after final frame

**Shift pawl**

Make sure the shift pawl is riding against the outside circumference of the film-metering cam, Fig. 19. After you shoot the final frame, the cam surface should push the shift pawl toward the front of the camera to disengage the main-gear clutch.

**Note:** The shift pawl sits on top of the switching cam, Fig. 29. When you set the 120/220 selector, the switching cam rotates to change the vertical position of the shift pawl. The vertical position determines which of two cam surfaces will push the shift pawl toward the front of the camera—the cam surface after the 10th exposure for 120 film or the cam surface after the 20th exposure for 220 film. Make sure that the shift pawl moves freely up and down as well as from side to side.

9. Shutter won't release, mirror rises fully

**Shutter gears, binding**

Push the 1st-curtain release lever, Fig. 30, toward the back of the camera—the 1st curtain should release. If not, check the curtain gears, Fig. 23 and Fig. 24, for binding. When you push the 2nd-curtain release lever, Fig. 30, toward the back of the camera, the 2nd curtain should release and the mirror should return.

**Shutter-mechanism plate**

When the mirror rises, the timing-checker lever, Fig. 16, releases the timing cam. The spring-loaded timing cam rotates clockwise and drives the 1st-curtain release lever against the 1st-curtain latch. If the timing cam won't turn clockwise, check for a broken spring (under the timing cam) or a bind in the timing cam.

10. Mirror won't return after exposure

**Shutter mechanism**

Push the mirror-return lever, Fig. 30, from left to right—the mirror should

return. If so, the 2nd-curtain gear isn't driving the mirror-return lever toward the front of the camera after the exposure. Check the reset-actuator lever, Fig. 24, for a bind.

#### Shutter-mechanism plate

After the exposure, the spring-loaded restoring gear, Fig. 30, should rotate counterclockwise to return the mirror and open the diaphragm. The restoring gear may be binding or the clock-type spring inside the restoring gear may be broken.

11. Mirror won't move up when you push release button

#### Timing, shutter-mechanism plate

Check for insufficient overtravel on the mirror-charge mechanism (*Adjustment Procedures* #10).

#### Shutter-mechanism plate

The mirror flip-up spring (under mirror-actuator disk, Fig. 30, may be broken.

12. Flash won't fire

**Note:** No contact at the X-sync terminal could mean a problem with either the FP-sync contact or the X-sync contact. The FP-sync contact acts as a safety switch for X sync—the FP-sync contact must close to provide ground for the X-sync contact.

#### FP-sync contacts

Check at the FP-sync terminal or the FP-sync contact at the sync-terminal contact plate, Fig. 37—you should get direct continuity to ground when the mirror rises.

#### X-sync contacts

Check at the X-sync terminal or X-sync contact at the sync terminal contact plate, Fig. 37—you should get direct continuity to ground when the shutter opens.

12. Advancing wind lever doesn't turn spool

#### Transport gears

Check the transport 2nd gear, Fig. 13, and the transport 3rd gear, Fig. 14. Studs on the bottom of the transport 2nd gear interlock with studs on top

of the transport 3rd gear to advance the spool—spring C119, Fig. 13, pushes down the transport 2nd gear to keep the studs interlocked.

#### 13. Film metering

For film-metering problems (uneven frame spacing, failure to get the full number of exposures on a roll, etc.), check the film-advance mechanism, Fig. 29. As the film turns the film-metering roller, Fig. 2, the counter 1st gear turns the counter-advance worm, Fig. 29. The counter-advance worm turns the counter gear and the film-metering cam, Fig. 15,

With the film advanced one frame, the film-metering cam allows the spool stopper, Fig. 29, to move counterclockwise—the upper tab on the spool stopper falls into a slot in the film-metering cam. The lower tab on the film stopper then locks the spool.

The spool remains locked until you release the shutter. After the exposure, the spool-release lever, Fig. 29, moves toward the front of the camera. The spool-release lever then

pulls the spool stopper out of engagement with the spool.

## SWITCH LOCATIONS AND CHECKS

**Power switch.** On main-switch assembly, side of mirror box, Fig. 38. Normally off. Closes as the mirror rises, switching battery power to the timing circuit and magnet.

**Checkpoint:** Pink wire to power switch, Fig. 38, or to wiring board at bottom of camera, Fig. 36. You should get 6V when you release the shutter.

**Timing switch.** On main-switch assembly, side of mirror box, Fig. 38. Closed with the shutter cocked, shorting across the timing capacitor. Opens as the 1st curtain releases, allowing the timing capacitor to start charging.

**Checkpoint:** White wire to main-switch assembly, Fig. 38, or to wiring board at bottom of camera, Fig. 36. You should get direct continuity to ground with the shutter cocked, no continuity with the shutter released.

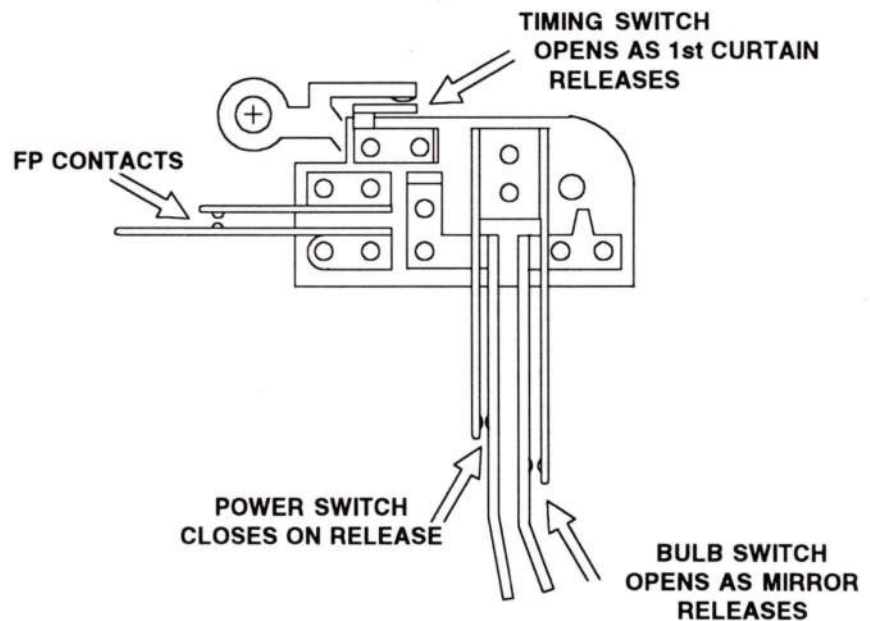

**FIG. 38 MAIN-SWITCH ASSEMBLY, RELEASE SIDE OF MIRROR BOX**

**Bulb switch.** On main-switch assembly, side of mirror box, Fig. 38. Normally closed. Opens when the mirror releases, keeping the shutter open on bulb operation. When you let up the release button, the bulb switch turns on; the timing capacitor charges, closing the shutter.

**Checkpoint:** Pink and brown wires on main-switch assembly, Fig. 38, or at wiring board, Fig. 36—direct continuity until you release the shutter. Or check by operation at the bulb setting. If the shutter won't stay open on bulb, the bulb switch may not be opening. If the shutter won't close on bulb, the bulb switch may not be closing.

**FP switch.** On main-switch assembly, side of mirror box, Fig. 38. Sync switch for the FP terminal and safety switch for the X terminal. Closes as the mirror rises, closing contact to the FP PC terminal and connecting the X PC terminal to ground.

**Checkpoint:** FP-sync terminal or FP contact on sync-terminal contact plate, Fig. 37. You should get direct continuity to ground when the mirror rises.

**X switch.** Bottom of camera, operated by 1st-curtain brake, Fig. 37 and Fig. 25. Closes as the 1st curtain crosses the aperture to fire a flash connected to the X terminal.

**Checkpoint:** X-sync terminal or X-sync contact on sync-terminal contact plate, Fig. 37. You should get direct continuity to ground when the 1st curtain crosses the aperture (if you don't get continuity, also check the FP switch—both the X switch and the FP switch must close to fire the flash at the X terminal).

**A-M switch.** Speed-knob side of mirror box, Fig. 22. Detects the lens type and setting for full-aperture or stopped-down metering—the A-M switch is open for full-aperture metering, closed for stopped-down metering. The small pin in the center of the lens-locking pin controls the A-M switch. When the lens-locking pin moves forward to lock the lens, the small pin allows the A-M switch to open (full-aperture metering). If you set the lens to manual, a lever at

the back of the lens pushes in the small pin to close the A-M switch.

**Checkpoint:** A-M finder terminal of meter coupler plate, Fig. 34 and Fig. 2. You should measure battery voltage when you push in the lens-lock button (A-M switch closes).

**Rotary switch.** Top, speed-knob end of camera, Fig. 22. Selects the resistance value according to the shutter-speed setting. The resistance controls the charging time for timing capacitor C1, Fig. 31—the higher the resistance, the longer it takes for C1 to charge and close the shutter.

**Checkpoint:** Pink and white wires to rotary switch, Fig. 33. You should measure different resistances at different shutter-speed settings. The typical resistance values are listed on page 29.

**BC switch.** Battery-check switch on rotary switch, Fig. 34. Closes when you push the battery-test button at the back of the left top cover. If the battery is o.k., TR7, Fig. 31, turns on to route current through the battery-test lamp.

## BASIC OPERATION, SHUTTER-MECHANISM PLATE

A failure of the mirror to rise or return indicates a problem with the shutter-mechanism plate at the side of the mirror box, Fig. 30. The following describes the functions of the shutter-mechanism plate:

### Mirror charge:

1. The shutter-mechanism plate controls the mirror, diaphragm, and shutter-release operations. Advancing the wind lever turns the mirror-intermediate gear, Fig. 30, through the mirror-charge shaft and connecting gears. Interlocking studs couple the mirror-intermediate gear to the mirror-double gear (under the mirror-intermediate gear). During the charge cycle, the two gears turn counter-clockwise.

2. The mirror-double gear turns the diaphragm-charge gear (the sector gear under the restoring gear, Fig. 30)

clockwise to charge the diaphragm-actuator spring. The other end of the diaphragm-actuator spring hooks to the diaphragm-actuator lever. As yet, the diaphragm-checker hook, Fig. 30, prevents the diaphragm-actuator lever from moving down.

3. The mirror-double gear also turns the restoring gear, Fig. 30, clockwise. The restoring gear tensions the restoring spring, a clock-type mirror-return spring inside the restoring gear.

4. As the restoring gear moves clockwise, it turns the center gear, Fig. 30. The center gear tensions another clock-type spring—the flip-up spring. One end of the flip-up spring connects to the center gear; the other end hooks to the underside of the mirror-coupling cam, Fig. 30. The mirror-lifting lever inside the mirror box connects to the mirror-coupling cam. As yet, the mirror-coupling cam can't turn—it's held by the mirror hook, Fig. 30.

5. At the end of the charge cycle, the reset hook (under the center gear) engages and holds the center gear. Latching the center gear also holds the restoring gear against the tension of the restoring spring.

6. The center gear also turns the timing gear (under the timing cam, Fig. 30) in a clockwise direction. The timing gear tensions the timing-cam spring (between the timing cam and the timing gear). In the charged position, the timing-cam spring moves the timing cam slightly clockwise—from the position shown in Fig. 18 to the position shown in Fig. 16. Here the timing-checker lever, Fig. 16, latches the timing cam.

7. In the charged position, Fig. 16, four springs are tensioned:

- ✓the diaphragm-actuator spring on the diaphragm-actuator lever for operation of the diaphragm
- ✓the restoring spring inside the restoring gear to return the mirror
- ✓the flip-up spring under the mirror-coupling cam to raise the mirror
- ✓the timing-cam spring under the

timing cam to release the 1st curtain.

8. As the wind lever returns, the mirror-intermediate gear turns clockwise. The other parts remain in the latched and tensioned positions.

#### **Mirror and shutter release:**

1. All the release operations are mechanical—the electronic control only holds the 2nd curtain for the length of the exposure. When you push the release button, the release plate, Fig. 30, pulls up the release-coupler plate. The release-coupler plate moves the shutter-actuator lever, Fig. 30, toward the back of the camera.

2. The edge of the shutter-actuator lever comes against a post on the diaphragm-checker hook. Now the shutter-actuator lever pushes the diaphragm-checker hook out of engagement with the diaphragm-actuator lever. The diaphragm-actuator spring pulls down the diaphragm-actuator lever, closing the lens diaphragm.

3. As the diaphragm-actuator lever moves down, its spring-hooking post strikes the lower end of the mirror hook. The mirror hook then disengages the mirror-coupling cam, Fig. 30. Now the flip-up spring drives the mirror-coupling cam counterclockwise. The mirror-lifting lever, attached to the mirror-coupling cam, raises the mirror.

4. The large lobe on the mirror-coupling cam strikes the lower end of the timing-checker lever, Fig. 16. The timing-checker lever disengages, allowing the timing cam to turn clockwise. The post on the timing cam strikes the underside of the 1st-curtain release lever. The upper end of the 1st-curtain release lever disengages the 1st-curtain latch to release the 1st curtain.

5. The 2nd curtain remains held as long as current flows through the magnet. To end the exposure, the circuit switches off the magnet. The magnet releases its armature, allowing the 2nd-curtain release lever to

disengage the 2nd-curtain latch.

#### **Mirror return:**

1. As the 2nd curtain completes the exposure, the 2nd-curtain gear drives forward the reset actuator, Fig. 24. The lower end of the reset actuator drives the reset hook out of engagement with the center gear.

2. Since the center gear can now turn, the spring-driven restoring gear turns counterclockwise. The restoring gear turns the center gear clockwise. A tab on the center gear picks up a lobe on the mirror-coupling cam; the mirror-coupling cam also turns clockwise, moving down the mirror-lifting lever to return the mirror.

## **OPERATING INSTRUCTIONS**

1. Without film in the camera, the shutter won't charge—the wind lever advances freely, turning only the spool. When you load film and close the back cover, advancing the wind lever advances the film. The film turns the film-metering roller, and the film-metering roller turns the counter dial. Once the counter dial reaches "1," continuing to advance the wind lever charges the curtains and the mirror.

2. Set the film type (120 or 220) with the 120/220 selector at the release end of the camera, Fig. 1. With 120 film, the counter disengages after the 10th exposure. With 220 film, the counter disengages after the 20th exposure (after the 21st exposure with the old-style camera).

3. If the battery is too low for proper operation, the mirror locks up when you push the release button—moves part way up and stops. The shutter doesn't release. After you replace the battery, push in the mirror-release button (front of body, release side of lens), Fig. 1. The mirror moves up the rest of the way. Then push the release button to return the mirror.

4. The mirror lock-up lever is at the

release side of the lens mount, Fig. 1 (the old-style camera does not have the mirror lock-up feature). With the shutter charged, push up the mirror lock-up lever—the mirror rises without releasing the shutter. Then push the release button to release the shutter and return the mirror.

5. Check the battery by pushing the battery-test button (back of camera, back-latch end). If the battery is good, the lamp visible at the top of the left top cover turns on.

6. For full-aperture metering, install the lens first and then the finder. If you reverse the order, you'll only get stopped-down metering.

7. After changing the lens, disengage and lift the TTL finder. Then reseat the finder for proper full-aperture coupling. To get stopped-down metering, set the preview lever on the lens to the manual position. Or remove and replace the lens.

8. The counter-transport button, Fig. 2, allows the owner to check operation without film. Open the back cover. Then depress and turn the counter-transport button until the counter dial moves past "1." Close the back cover or install the coin plate (supplied with the camera). Advancing the wind lever now charges the mirror and shutter.

9. There are five interchangeable focusing screens for the 6x7. However, the owner can't install the screen—replacing the focusing screen disturbs the adjustment. To install a different focusing screen, turn in each of the three adjustment screws, Fig. 20, while counting the number of turns. Then remove the three adjustment screws and springs. After replacing the screen, turn in each adjustment screw fully. Back out each adjustment screw the number of turns you counted during disassembly.

## **OTHER COMMENTS, PART NUMBERS**

1. To check film metering, it helps to

make a special test roll from a properly operating camera. Load and advance the film to the 1st frame. Hold open the shutter on bulb. Use a marker to trace the shape of the focal-plane aperture on the film—mark the frame "1." Repeat the procedure until all the frames have been drawn and marked, Fig. 39.

When you use the test roll to check a customer's camera, hold open the shutter on bulb to check the alignment.

2. If the film winds too loosely on the spool, check the film roller on the back cover—a broken film roller may require replacing the back cover.

3. Adjustments on the TTL pentaprism finder are on the speed-knob side of the prism. Fig. 40 shows the locations of the adjustments you may have to make for accuracy. If there are only three variable resistors on the board, use the center VR to adjust full-aperture metering. Use the VR to the back of the camera to adjust stopped-down metering. Do not disturb the VR toward the front of the camera.

#### 4. Frequently replaced parts:

damper spring (brake)—E18  
main gear—0-C1-01  
winding-lever ratchet—0-C28-03  
main-switch assembly—0-D101  
wind-lever shaft assembly—A0-C34-02  
chain A (chain that connects to coupling ring, Fig. 20)—B90  
chain B (chain at top that connects to spring, Fig. 20)—B91

#### 5. Covers:

back cover—0-A6  
right side cover—0-A2  
left side cover—A0-A3-02  
bottom cover—A4  
right top cover—2-A7  
right front cover—1-A96-02  
left front cover—A97-01

#### 6. Body covering (leatherette):

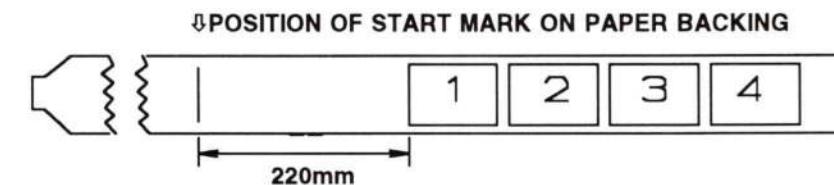

FIG. 39 TEST FILM

front right—A110-01  
front left—A111  
side right—A112  
side left—A113  
bottom—A114

#### 7. Mirror-charge and shutter-mechanism-plate parts:

mirror-charge 1st gear with mirror-charge shaft—0-C2  
mirror-charge 2nd gear, Fig. 18—C4  
mirror-gear block—0-C9  
mirror-charge 5th gear—0-C7-01  
flip-up spring—D19  
restoring spring—D27  
timing-cam spring—D8-01  
diaphragm-actuator lever—0-D28  
diaphragm-actuator-lever spring—D31  
shutter-mechanism plate (complete assembly)—A0-D1

#### 8. Film-advance and metering parts:

transport 2nd gear—C43-02  
spring for transport 2nd gear—C119  
transport 3rd gear—C44-02  
counter 1st gear—0-C93-01  
spool stopper—1-C20

shift pawl—0-C24  
shift-pawl spring—C113  
lever pawl—0-C23  
spring for winding-lever ratchet—C124

#### 9. Shutter parts:

release-stopper plate—0-E88  
curtain latch (both latches the same)—E82  
curtain-charge gear—0-E80  
1st-curtain gear—0-E75  
2nd-curtain gear—0-E76  
1st-curtain assembly—0-E63  
2nd-curtain assembly—0-E59-01

#### 10. Other parts:

battery case—0-B23-01  
tripod socket—B32  
counter-transport button spring—C132-01  
shutter-mechanism plate assembly—A0-D1  
rotary switch assembly—0-E128-01  
circuit board—0-K1  
back-cover hinge—A11  
mirror—L1  
magnet—0-D113-01  
wind-lever spring—C58  
counter dial—0-C52  
counter-transport button—C131  
spring for counter-transport button—C132-01  
rotary-switch assembly—0-E128-01  
battery-test lamp—E127-01  
120/220 selector (frame-control dial)—C105

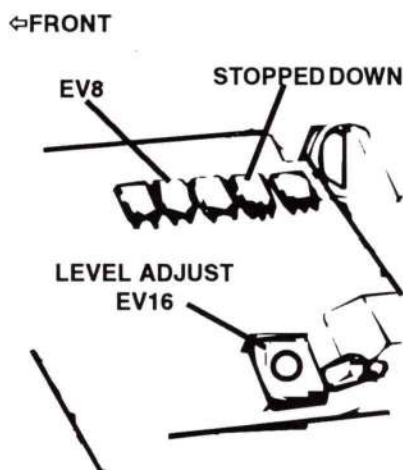



FIG. 40 SPEED-KNOB SIDE OF CIRCUIT BOARD, TTL FINDER

 SPT acknowledges with gratitude the cooperation of Pentax, Inc., in the preparation of this article.