

Disassembly and Drawings by Tetsuo Koyama

MODERN'S INSIDE YOUR CAMERA SERIES #35 OLYMPUS OM-4

Was the 35mm SLR already so well developed that only minor improvements to its basic design were possible? Olympus thought not, and proceeded, after more than seven years of toil and high-tech ingenuity, to give us the OM-4, the first SLR to combine exquisitely precise multiple spot-metering and full automation in a supremely compact, OM-sized body. Here, as told to us by two of the OM-4's principal designers, is how and why they did it.

by Y. Maitani and K. Tsunefuujii

A decade ago, Olympus introduced the OM-1, first of a generation of extremely compact, full-featured 35mm SLRs. Three years later, it brought forth the equally compact OM-2, the first SLR to incorporate direct, through-lens metering off the film and/or patterned shutter curtain, and TTL autoflash. Finally, late in 1983, Olympus announced the OM-4, the first SLR to combine all the salient features of a sophisticated professional exposure meter, plus a comprehensive LCD finder readout system, in a traditional OM-sized body.

As the name suggests, the OM-4's Multi-Spot Metering system is capable of measuring discrete, limited areas of the subject, either individually or in multiple readings which are automatically integrat-

ed into a single exposure. Suppose, for example, that you see areas of sharply different brightness within the frame. After you select the precise areas you want to be included in determining the exposure, and take separate readings of each, an on-board computer calculates and integrates them into the exposure you'll get when you press the shutter release. For instance, you might choose to take two separate readings of highlight and shadow areas of a face, plus a third reading off the subject's clothing.

The exterior design of the OM-4 represents a logical extension of the OM-1 and OM-2. In fact, the basic body shape and control arrangement of the OM-4 is quite similar to that of the previous models.

Continued on page 136

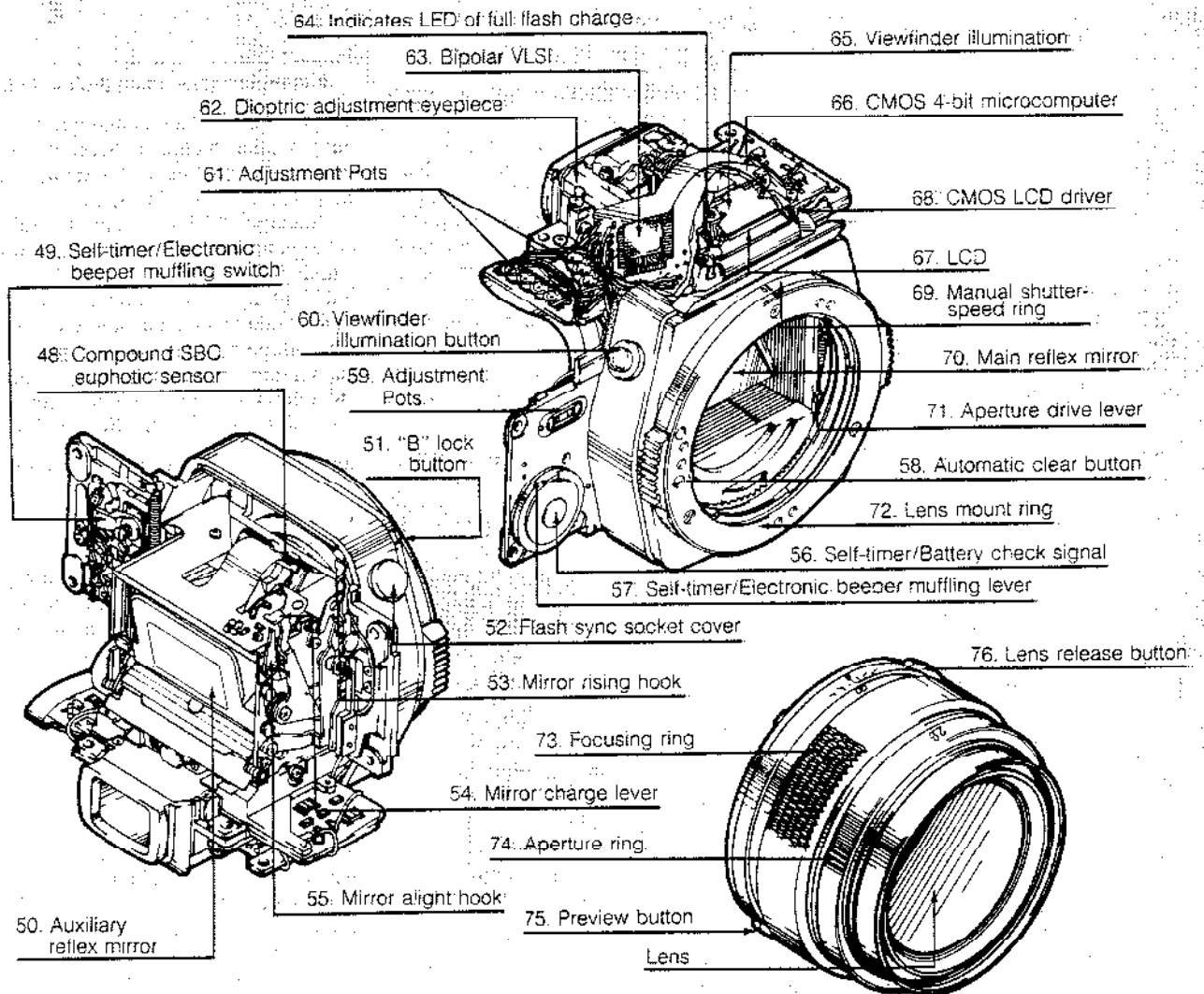

INSIDE YOUR CAMERA

Continued from page 79

Existing motor drives, film winders, data backs, 250-exposure backs and, of course, all lenses are fully interchangeable among all four OM models, including the OM-3. This modular "systems" approach allows photographers to add a wide variety of specialized accessories.

The pentaprism housing section atop the OM-4 was designed for maximum compactness, yet it contains some of the camera's most important and innovative features. These include complex electronic circuits, the new, all-LCD finder read-out systems, and the adjustable diopter eyepiece. Considerable effort and ingenuity were required to get such an enormous amount of new electronics and precision mechanics into a body as compact as the OM-4's. Indeed, this was the major hurdle faced by the OM-4 design team.

Another difficult engineering problem was devising a multi-function, spot metering system that was comprehensive yet easy to use. To provide easy access to the OM-4's unique metering functions, a cluster of buttons adjacent to the shutter release was employed, each of whose size, shape and position was determined on principles of "human engineering" and after considering their frequency of use. The aim was to have them be easily located by feel and operable at the touch of a fingertip with the camera at eye-level. Of particular importance was the "front right-hand" placement and design of the memory "all clear" lever, which holds or cancels all spot readings if the photographer changes his mind.

The OM-4's electronic circuitry

Functionally, the most important and distinctive of the OM-4's internal systems is its on-board microcomputer and associated mechanisms. Of course integrated circuits (ICs) have been at the core of camera electronics for over a decade, including the Olympus OM-2 of 1975.

In contrast to the OM-2's electronics, the OM-4's circuitry provides multiple programs to control various new functions. In addition to TTL direct light measuring (as in the OM 2), these include spot metering, multi-spot metering, an AE lock (which instantly memorizes light measurement values), a calculator function (which executes the optimum exposure based on values stored in the memory), and finally, highlight and shadow functions (which calculate and execute exposure based on the photographer's preferences in overall tonal rendition). Moreover, automatically read exposure values are memorized and may be recalled by the memory function for up to 60 min. In autoflash mode, the OM-4 provides an automatic "judgment" function which corrects the flash exposure in either direc-

tion based on a single manual setting, and fires the flash only when it's needed to obtain the correct exposure.

In addition to the above, the OM-4 incorporates many subordinate functions, including self-timer, battery check, viewfinder display cutoff, finder illumination cutoff, etc. These numerous and complex functions are electronically interrelated and user-selected.

All the OM-4's multiple functions are organized in a manner similar to the systems of large-scale computers. Essentially, the camera's computer system consists of the following four "packages": 1. The CPU (central processing unit) of the microcomputer, which is the nucleus of the system. 2. The light-measuring sensor, consisting of the SPD (silicon photodiode) and amplifier. 3. Large-scale bipolar IC which contains an analog-to-digital (A-D) converter. 4. The LCD driver IC which controls the camera's viewfinder display.

The OM-4's computer system

Perhaps the easiest way to explain the operations of the OM-4's on-board computer system is to compare its functions to those found on a typical big computer.

To begin with, the OM-4 provides "input units" that are analogous to a large computer's input keyboard. These are: The shutter-release button, auto-manual switching lever, spot-metering button, memory/all clear lever, viewfinder illumination button, self-timer lever, shutter-speed ring, and flash control terminal. Operating instructions from these "input units" are transmitted to the CPU. The processing unit monitors the input instructions by means of time sharing in order to respond as efficiently as possible to any series of input instructions.

The most important functional element of the OM-4, the light-measuring sensor, controls both spot and averaging light measuring. Switching in this two-mode system is controlled by the spot-metering button which "tells" the CPU to switch over to spot-metering mode. First the sensor reads the light as an analog value, which is then converted into a digital value by the A-D converter. The exposure value is then stored in the multi-spot AE Look RAM (random access memory) in the microcomputer. All individual spot exposure readings and any further instructions from the aforementioned "inputs" are stored and processed in the operation register. This processed information is always displayed on the LCDs in the finder. In other words, the OM-4's finder displays are equivalent to the CRT (cathode ray tube) displays of large computers. Thus the photographer can always monitor the processed information contained in the microcomputer while continuing to view and to focus through the camera at eye level.

Continued on page 138

INSIDE YOUR CAMERA

Continued from page 136

This full-time monitoring capability is made possible by the time-sharing system of the CPU, which transmits the results of all calculations immediately to the LCD driver. At the same time, the CPU outputs the results of these calculations to the shutter-speed ICs in order to control the exposure. Both AE shutter speeds and flash brightness are controlled in a similar manner, the end results of any of these processes being a single, correct-exposure value.

Once an exposure value has been calculated, the CPU determines whether

nology, including stacking the IC packages on both sides of an ultrathin flexible circuit.

Each integrated circuit, designed for minimum power consumption, is driven at 3 volts at very low amperage. Much time was spent in analyzing the OM-4's diverse electronic systems during the development of the CPU, which is controlled by a CMOS, 4-bit, 4-byte micro-computer. The development of the LCD finder display system proved to be especially difficult. The LCD contains more than 100 different alphanumeric elements, and each one is tiny—some measuring only 10 microns. Also, the display had to be legible over the extremely wide temperature range.

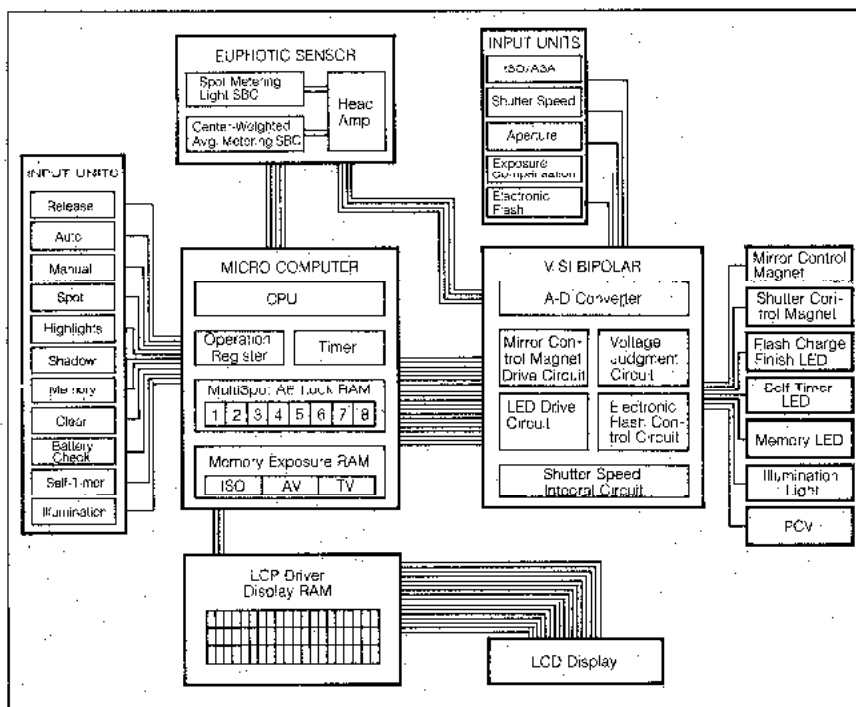

The OM-4's Electronic Heart: The camera's innovative IC system for exposure control, diagrammed for clarity.

flash is required to achieve the proper exposure, and prepares itself to accept input information for the next exposure. Thus the CPU processes and transfers information among the "input units," light-measuring sensor, LCD finder display, and the exposure control unit—an array of functions equivalent to full-scale data processing in large computers.

Packaging the system

Getting the complex, large scale electronic system outlined above into the compact body dimensions of the OM-4 proved to be a tough assignment for Olympus. Early prototype OM-4s had much larger pentaprism housings than previous OM-series models, but Olympus deemed this "big-bodied" OM-4 unacceptable, and began the difficult task of packing more features into a smaller space than ever before. The ICs were packaged more compactly by using advanced tech-

In order that the LCD display be as legible as possible without causing eye strain, the designers chose the so-called "negative display" method—light figures against a darker background.

The LCD display

The OM-4's exposure information display panel is situated below the viewfinder screen. In automatic exposure mode, numerals from 1 to 2000 are arrayed horizontally, and the camera-selected shutter speed is indicated by a dotted bar. This bar extends and contracts in response to the lighting conditions, and its tip indicates the shutter speed the camera will provide when the shutter release is pressed. The individual unit dots comprising this line indicate the exposure in $\frac{1}{2}$ EV increments, providing approximately the same precision and "single glance" readability as an analog readout system. When

Continued on page 142

INSIDE YOUR CAMERA

Continued from page 138

the user selects the spot-metering mode, a diamond-shaped dot appears above the bar to mark each individual spot-metering value up to a total of eight separate readings. Viewing these dots shows, at a glance, the distribution of exposure readings, so the photographer can easily grasp the range of exposure values and balance of each scene or subject. In the spot reading mode, the bar still indicates the proper-exposure shutter speed, but in this case it represents the calculated value of the entire series of spot readings.

The sophisticated finder display is one of the major factors enabling OM-4 users to control the camera's multi-spot metering system with ease and confidence. But to achieve maximum efficacy from its design Olympus had to improve the viewfinder eyepiece also.

The most singular aspect of the OM-4's finder eyepiece is that it provides a wide range of diopter adjustment for eyesight variances. This not only enables more precise viewing and focusing, but also allows the photographer to read the complex finder displays clearly and with instant recognition. In designing the eyepiece, special emphasis was placed on the following capabilities: 1. A wide adjustment range for dioptric correction (between +1.0 and -3.0 diopters). 2. A high viewfinder magnification. 3. Minimizing distortion in the viewfinder image when the photographer fails to center his eye behind the eyepiece when looking through the finder. 4. Achieving a compact design with a comfortable and pleasing shape.

The OM-4's Dioptic Adjustment Eyepiece

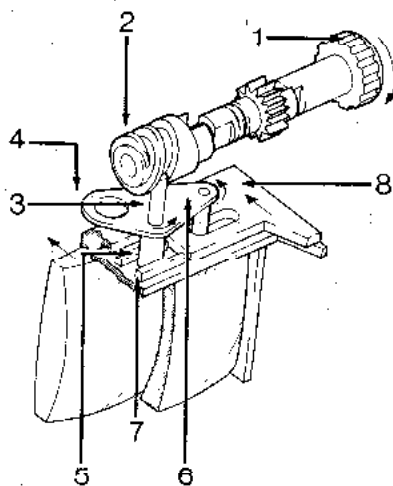

Turning gear (1) causes distance between front and rear eyepiece to change, thus varying its focal length to suit individual eyesight (see text for operational details).

The drawing below left shows the OM-4's eyepiece adjustment mechanism. Pull out knob (1) on the left-hand side of the pentaprism housing and the knob is now free to rotate. By rotating this diopter-adjustment knob while sighting through the finder, you can select the position that's optimal for your personal eyesight. Here's how it works. When you rotate knob (1), screw channel (2), which is connected to knob (1), travels along pin (3) causing lever (4) to turn counter-clockwise. Pins (5), and (6) affixed to lever (4), now move laterally in their respective channels, causing frame (8) holding the front eyepiece lens to move forward with respect to frame (7) which contains the rear eyepiece lens. In this manner the optical strength of the compound eyepiece lens is varied.

OM-4's Metering System

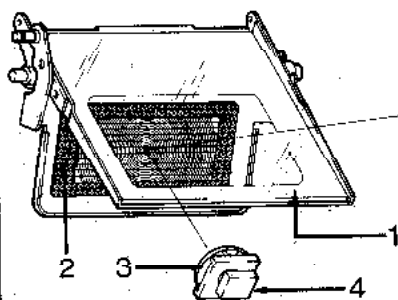

20% of light striking main mirror (1) passes through to secondary mirror (2) and is reflected down to Compound Euphotic Sensor (3 and 4) in base of body. (See text for additional details).

The drawing above illustrates in detail the metering mechanism. The main mirror (1) is a special semi-transparent mirror which is multi-layer coated on both sides. This special mirror reflects 80% of the incoming light rays up to the viewfinder, while the remaining 20% are reflected downwards, via a subsidiary mirror (2) to the light-measuring sensor. A three-lens optical assembly (3) which includes an aspherical element and an infrared cutout filter, is located in front of the stationary sensor (4).

Although the basic shutter mechanism of the OM-4 is based on the shutters found in previous OM models, over 50 different improvements were made to achieve a stable 1/2000 sec. shutter speed along with improved overall accuracy. Improvements found in the OM-4's accessories include motor driven film rewinding and the ability to attach and remove the motor with film loaded.

With rare exceptions, single-lens reflex cameras have stuck with center-weighted metering systems for the best part of two decades. With the emergence of the OM-4, we now have multiple spot-metering sophistication and more precise user control of the exposure process. —THE END