

# NIKON FG

Similar models: EM  
(mechanically similar)

Batteries: 2 each S-76  
(negative ground)

Fig. 1— front view, nameplate and  
leather removed

Fig. 2—top cover removed

Fig. 3—bottom cover removed

Fig. 4—top view, wind side

Fig. 5—top view, rewind side

Fig. 6—top view, speed-selector  
assembly removed

Fig. 7—top view, flex connector

Fig. 8—top view, flex connector  
disconnected

Fig. 9—front view, mirror box  
removed

Fig. 10—mirror box, back view

Fig. 11—mirror box, wind side

Fig. 12—mirror box, rewind side

Fig. 13—mirror box separated from  
front plate, wind side

Fig. 14—underside of wind seat

Fig. 15—shutter block

Fig. 16—top view, SV (ASA) resistor

Fig. 17—top view, TV contacts

Fig. 18—FPC wiring, bottom of  
camera

Fig. 19—FPC wiring, top of camera

Fig. 20—wiring, fo base plate  
(maximum-aperture  
resistor)

Fig. 21—I2L (CPU) IC, pin voltages

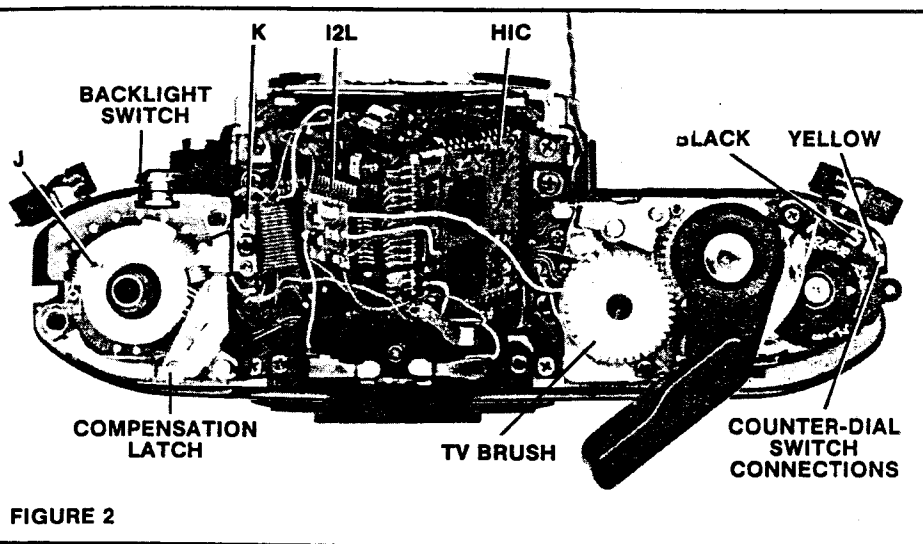
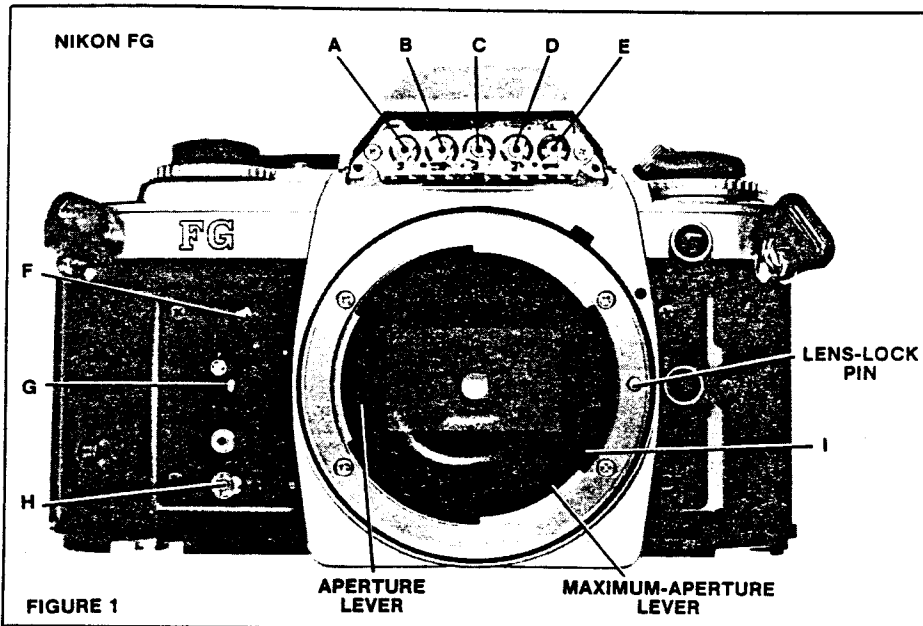

Fig. 22—HIC (hybrid IC), pin  
numbering and wiring

Fig. 23—schematic

## ADJUSTMENTS LOCATIONS:

Auto exposure, A mode	A
Warning signal, P mode	B
Auto exposure, P mode	C
TTL flash cutoff	D
LED readout	E

Release-button overtravel	F
Release-button switch	G
Shutter release (mirror height)	H
Mirror angle	I
SV brush	J
LED display, position	K
Mirror release	L
Mechanical-speed release	M
Mirror switch	N
Aperture lever position (charged)	O
Program switch	P

Aperture lever position (released) Q  
 Travel time, second curtain R  
 Travel time, first curtain S\*  
 Trigger (timing) switch T  
 \*normally not necessary to adjust

**ADJUSTMENT VALUES:**

Curtain-travel time: 5.8ms (20mm distance)

Flange-focal distance: 46.67 + or - 0.02mm (flange to pressure-plate rails)

P-mode warning: In the P mode, the under and over warning LEDs should flash alternately at  $f/11 + or - 1/6 AV$ . At  $f/16$ , the LED display should show the shutter speed.

Mechanical-speed release: Without batteries, the mirror should lock up at 1 second. Turning the speed dial to M90 should cause the shutter to release. The shutter should release when the speed dial is half way between 1 second and M90. To adjust, change the space gap of the mechanical-release lever, Fig. 8 (adjustment M). Spread the arms of the mechanical-release lever to make the shutter release sooner. Decrease the space gap between the arms to make the shutter release later.

Mirror release: Adjust eccentric L, Fig. 8, on the continuous lever for the mechanical release at M90. First turn the eccentric counterclockwise until the mirror does not release. Then turn the eccentric clockwise until the mirror just releases. From this point, turn the eccentric an additional 45° in a clockwise direction.

Shutter release (mirror height): The shutter should release when the mirror is 1 - 3mm from the porous-plastic strip at the top of the mirror box. To check, hold the mirror and push the release button. Allow the mirror to rise slowly. The shutter should release when the distance between the mirror and the porous-plastic strip is about the same as the thickness of the porous-plastic strip. Adjust with eccentric H, Fig. 1.

Release-button overtravel: The mirror should release when the release button moves down a distance of 0.4 + or - 0.2mm (measured from the top of the wind-lever retainer). Adjust with eccentric F, Fig. 1.

Battery check: If the battery voltage drops below 2.45 - 2.35V, the 16-

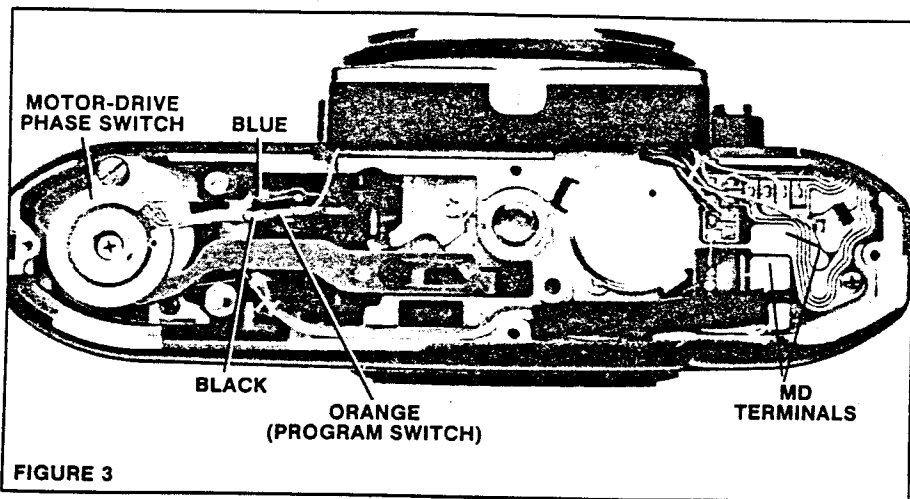

FIGURE 3

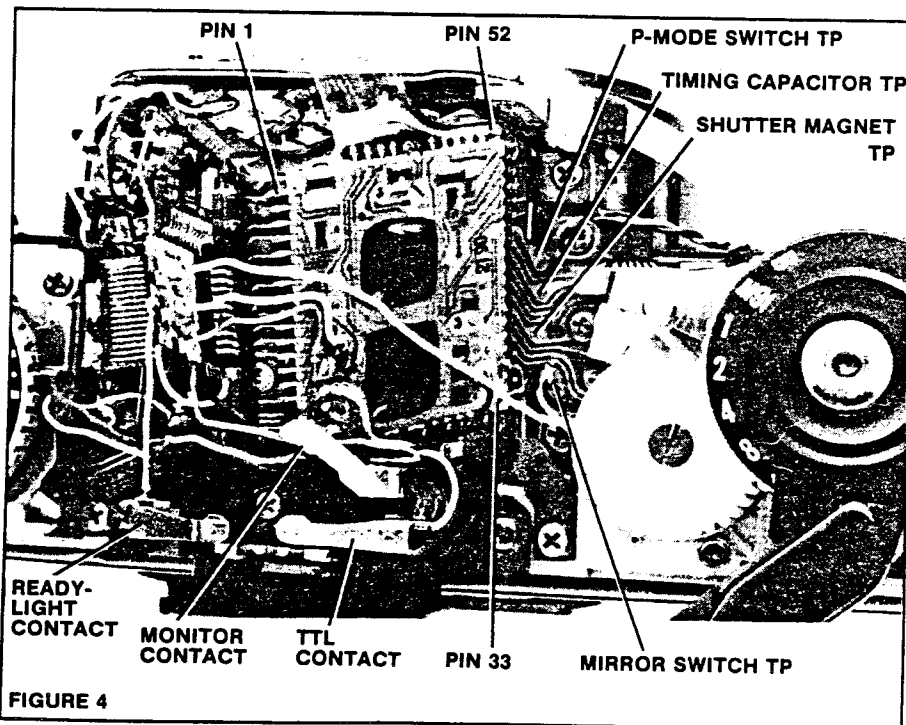

FIGURE 4

second timer will not hold on the LEDs. With less than 2.35V, the mirror locks up and the shutter doesn't release.

LED display, position: Check the LEDs with the counter dial in the start position. Only the "60" and the "125" LEDs should show. If these two LEDs do not show clearly — or if you can see another LED — shift the position of the LED display. Loosen the center screw. Then use the positioning screws, Fig. 2 (K) to raise or lower the ends of the LED display. Do not overtighten the center screw after the adjustment — the screw will bend the LED display. Just turn down the screw against the display and lock the screw with lacquer.

Aperture lever: Check the distance between the bottom of the aperture

lever, Fig. 1, and a horizontal line drawn through the center of the lens-lock pin. With the mirror charged, the distance should be 3.1mm. With the mirror box released, the distance should be 3.5 - 3.7mm.

Timing, TV brush and coupling gear: If you remove the TV-brush gear, Fig. 2, note the timing mark on one tooth. Align this timing mark with the timing mark on the coupling gear.

**SWITCH ADJUSTMENTS:**

1. Mirror switch  
 Adjust before replacing the mirror box, Fig. 11. Connect an ohmmeter between the pink and black mirror-switch wires. With the mirror box released, the mirror switch should be open.

Now use your finger to push down the mirror until the mirror touches the mirror stop (inside mirror box, rewind side). The mirror switch should still be open. Slightly push the mirror against the mirror stop (the spring action of the mirror stop allows the mirror to move down slightly further). The mirror switch should close when you push the mirror against the mirror stop. Adjust with eccentric N, Fig. 11.

2. Program switch

Adjust with the mirror box removed from the front plate, Fig. 13. Check with the mirror box released, mirror down. Push the continuous-release hook, Fig. 13, toward the front of the mirror box. The space gap between the contacts of the program switch should now be  $0.4 \pm 0.1\text{mm}$ . Adjust with setscrew Q, Fig. 13.

3. Release-button switch

Adjust before or after installing the front-plate/mirror-box assembly. The release-button switch should close when the release button moves down  $0.6 \pm 0.2\text{mm}$ . Make sure the LED display turns on before the shutter releases. Adjust with eccentric G, Fig. 9. You can also reach the eccentric through the clearance hole in the front plate, Fig. 1.

**ADJUSTMENT SEQUENCE, EXPOSURE:**

Note: With the back open, the camera delivers only the mechanical speed. Use a piece of soft plastic to wedge in the back-sensing lever. Then advance and release until the counter dial reaches the "1" position. Alternately, you can temporarily short the two contacts of the counter-dial switch (black and yellow wires, Fig. 2).

1. Auto exposure

Check in A mode, f/5.6, ASA 100, EV 12. Adjust A, Fig. 1, for 0 EV error or for a shutter speed of 7.37ms (6.88 - 7.9ms).

2. LED readout

Check in A mode, f/5.6, ASA 100, EV 12. The "125" LED should turn on. Adjust with E, Fig. 1. Then check at EV 15 — the "1000" LED should be on. If not, readjust at EV 12. Also check at EV 6 — the "2" LED should be on. If not,

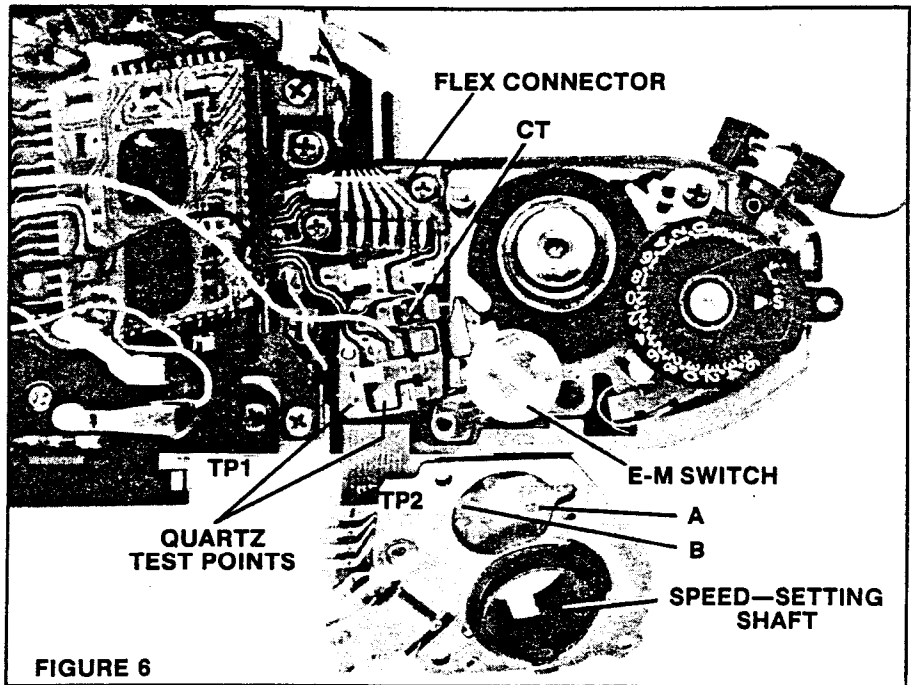
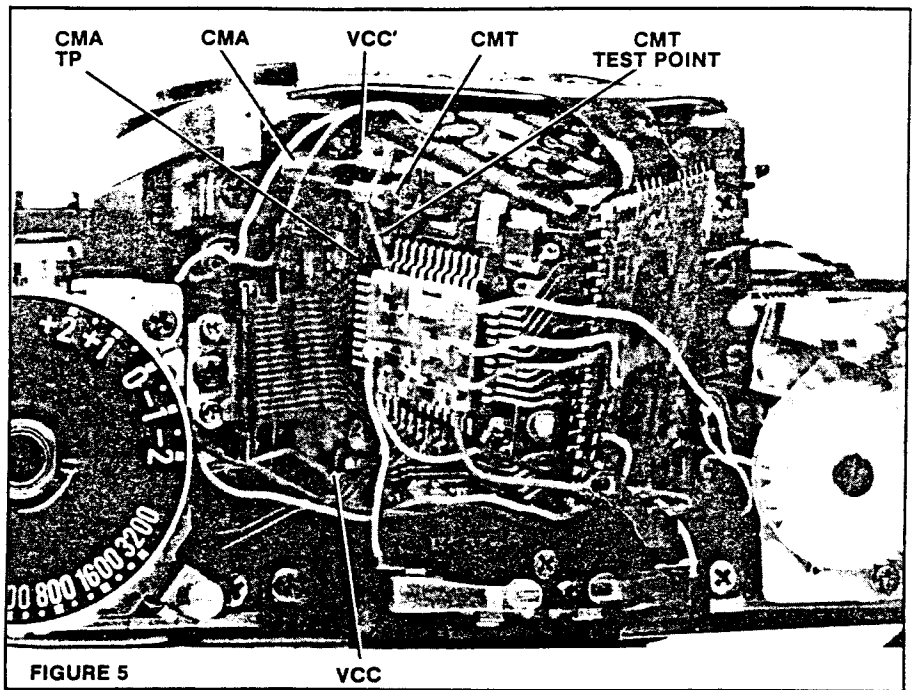

- 3. P-mode warning signal  
Set P mode, f/11. You should get the warning signal (over and under LEDs flashing alternately). At f/16, you should get the shutter-speed display. Adjust for the warning indication at f/11 with B, Fig. 1. Tolerance is  $\pm 1/6$  AV (turning the diaphragm-setting ring 1/6 stop on either side of f/11).
- 4. Program exposure  
Set P mode, ASA 100, f/22 (or smallest aperture of lens in use), EV 12. Adjust C, Fig. 1, for 0 EV error or for a shutter speed of

- 7.15ms (6.67 - 7.66ms).
- 5. TTL flash cutoff  
Requires Nikon special tool or a flash meter and the TTL flash unit (Nikon SB-15) to adjust. Using the flash meter technique, install an 18% neutral-gray card in the film position. Install the SB-15 flash on the hot shoe. Fire the flash at a neutral-gray test surface. Adjust D, Fig. 1, for the proper flash exposure.

**OPERATING INSTRUCTIONS:**

- 1. For film-loading, the camera delivers the mechanical speed

(1/90) until the counter reaches the "1" position. The LED display then shows the "60" and "125" LEDs flickering. As soon as the counter reaches "1," the LED display shows the proper shutter-speed indication.

2. The shutter-speed dial latches at A and P settings. Depress the latch button to free the shutter-speed dial.
3. For the program mode, set P and the smallest aperture. At an aperture of f/11 or larger, the LED display shows the P-mode warning signal — the over and under LEDs flash alternately. At an aperture setting smaller than f/11, the LED display shows the shutter speed the camera will program.
4. Pushing the release button part way turns on the LED display. A timer holds on the display for 16 seconds after you let up the release button.
5. At manual speed settings, the LED display may show two LEDs — a steady LED indicates the shutter-speed setting, and a flickering LED shows the proper setting for the light conditions. Set the proper shutter speed by turning the shutter-speed dial until there's only one LED illuminated.
6. The piezo crystal beeps for auto speeds of 1/30 or slower (slow-speed warning) or 1/1000 or faster (overexposure warning). The silencer switch on the top cover allows you to turn off the piezo beeper.
7. With a dedicated flash unit (SB-15, SB-10, SB-E), the flash ready-light LED in the display turns on when the flash charges. The "60" and "125" LEDs then glow steadily to indicate the flash speed of 1/90. If the shutter-speed dial is set to a manual speed of 1/125 or faster, the camera will deliver 1/90. At manual speed settings of 1/60 or slower, the camera will deliver the selected speed. The camera delivers 1/90 at the A and P settings.
8. With the TTL flash unit (SB-15), the camera shuts off the flash output. A silicon photodiode reads the light reflected from the film when the flash fires. A signal applied to the TTL contact, Fig. 4, shuts off the flash for proper

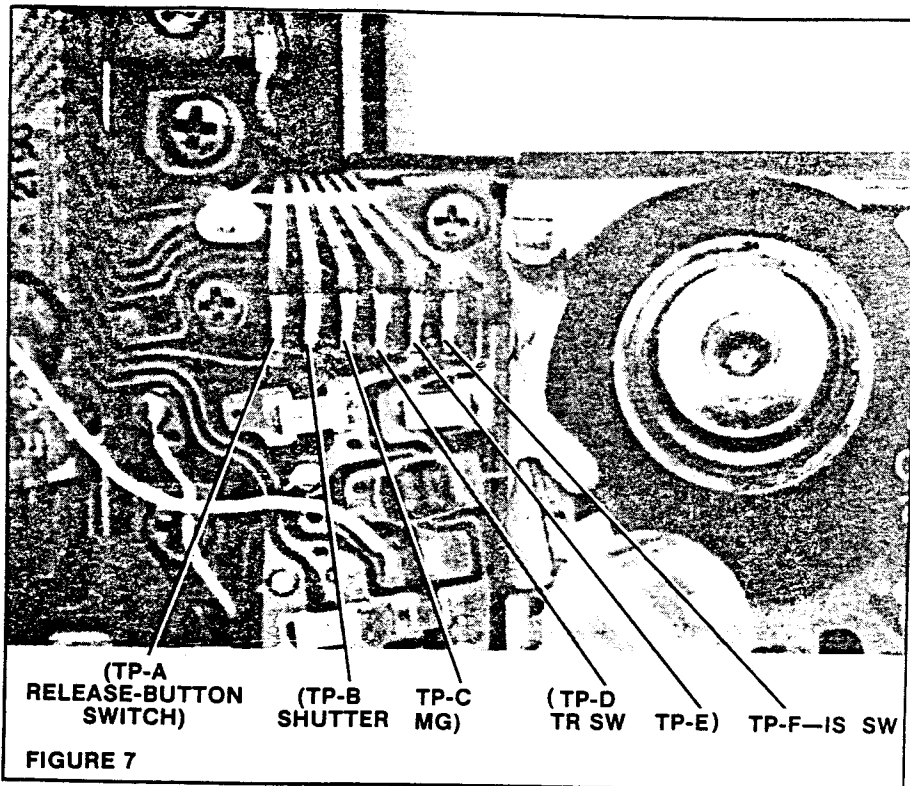

FIGURE 7

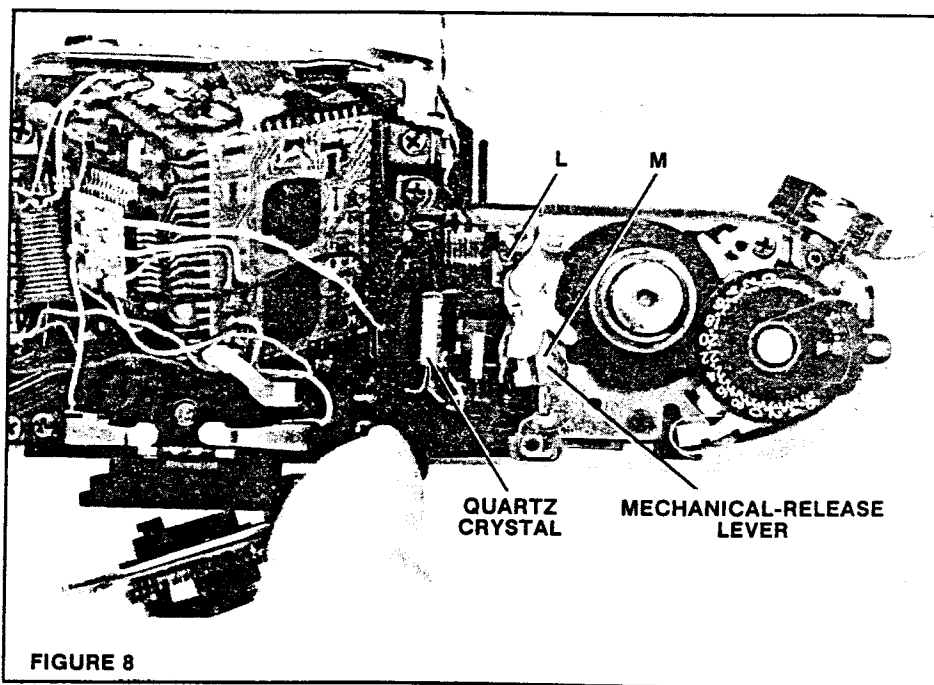

FIGURE 8

exposure. The flash inputs a signal to the monitor contact, Fig. 4, to tell the circuit there's a TTL flash installed.

#### OPERATION TESTS:

1. Check that the shutter delivers a speed of 11.7 - 11.9ms and that the "125" and "60" LEDs flicker until the counter dial reaches "1".
2. Set either P or A mode. Close the

camera back and advance the wind lever until the counter reaches "1". Set f/22 and cover the lens. Push the release button part way. The piezo should beep.

3. Set the P mode and remove the lens. Check the LED readout with the release button pushed part way; you should get the shutter-speed indication. Then move the maximum-aperture lever, Fig. 1, a slight distance toward the rewind side of the camera; the

display should now show the P-mode warning signal.

4. Set A or P mode. Check the flash-speed changeover by applying 1V between ground and the ready-light hot-shoe contact (the hot-shoe contact closer to the rewind side of the camera, or the orange-wire contact if you have the top cover removed). When you push the release button part way, the "60" and "125" LEDs should glow steadily. Increase the voltage to 2V. The ready-light LED (next to the electronic-flash symbol) should turn on.

#### LOCATIONS AND FUNCTIONS OF SWITCHES:

1. Release-button switch (half-way switch). At front of shutter, Fig. 9. Closes when you depress the release button half way to turn on the LEDs and apply the oscillator signal to I2L. The timer holds on the circuit for 16 seconds after the release-button switch opens.
2. E-M switch. Under the speed-selector assembly, Fig. 6. Switches the circuit on for electronic functions and off for mechanical speeds (M90 and bulb).
3. fo switch. On fo base plate, Fig. 10. Closed with no lens installed. Opens when the maximum-aperture lug on the lens pushes the maximum-aperture lever toward the rewind side of the camera. Opening the fo switch causes the P-mode warning signal to operate until the f-value ring reaches the f/16 position.
4. Program switch. On wind side of mirror box, Fig. 13. Normally open. Closes when the mirror rises, enabling the program mode.
5. Mirror switch. On wind side of mirror box, Fig. 11. Normally closed. Opens when the mirror moves up, locking the memory-capacitor voltages.
6. P-mode switch. On the TV-contact board, Fig. 17. Closes at the P mode to connect pin 46 of HIC to ground.
7. Trigger switch. In shutter block, Fig. 15. Closed with the shutter cocked. Opens when the first curtain starts to run, starting the timing cycle.
8. TV switches. Four digital switch-

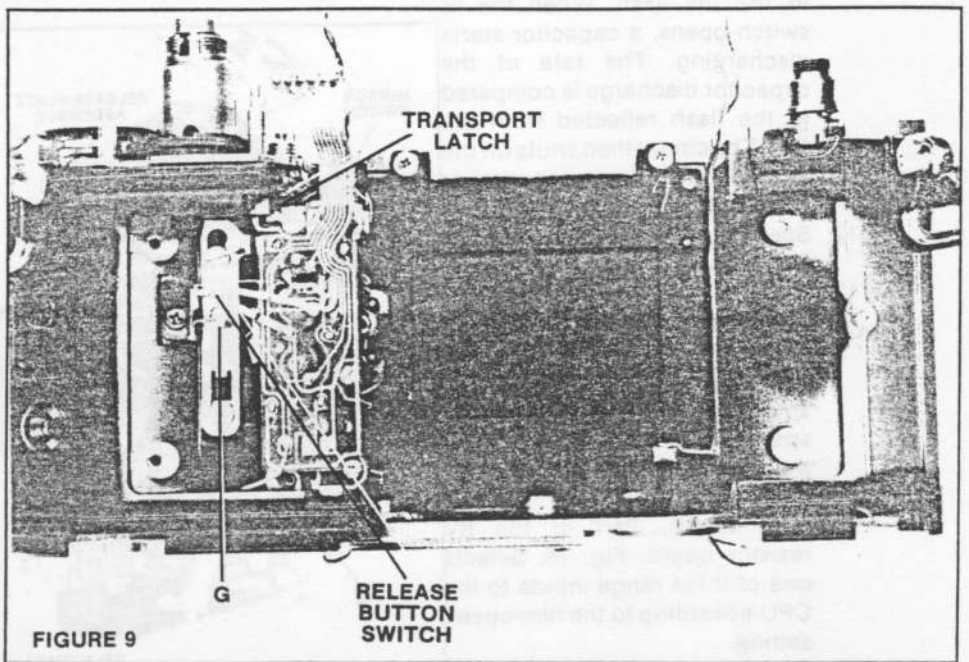

FIGURE 9

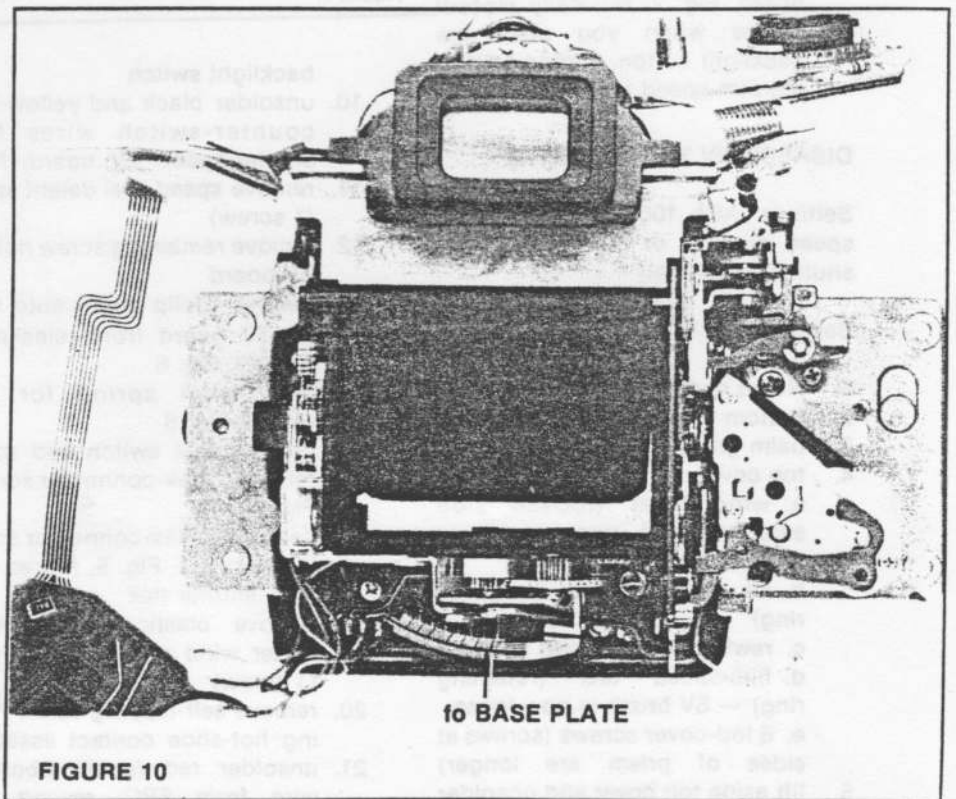

FIGURE 10

es opened or closed by speed selector, Fig. 17. The combination of opened and closed switches inputs a Gray-code signal to the CPU.

9. Second-curtain switch. At top of shutter block, Fig. 15. Closed with the shutter in the released position to start the motor drive. Opens as the second curtain moves to the cocked position.
10. Motor-drive phase switch. At bottom of wind shaft, Fig. 3.

Normally open. Closes during the cocking cycle to keep the motor drive running after the second-curtain switch opens. At the end of the cocking cycle, both the second-curtain switch and the motor-drive phase switch are open. The motor drive then turns off.

11. IS switch. In shutter block, Fig. 15. Normally closed (by the movable X-sync contact). Opens when the sync contact is moved

to fire the flash. When the IS switch opens, a capacitor starts discharging. The rate of the capacitor discharge is compared to the flash reflected from the film. The circuit then shuts off the TTL flash output for proper exposure.

12. Silencer switch. In top cover. Turns on or off the piezo beeper.
13. Counter-dial switch. At wind-lever end of camera, Fig. 2. Open until the counter dial reaches the "1" position, causing the shutter to deliver the mechanical speed for film-loading. Closed by the counter dial at the "1" position.
14. ASA switch. Part of the SV resistor board, Fig. 16. Selects one of three range inputs to the CPU according to the film-speed setting.
15. Backlight switch. Under the SV board, Fig. 2. Normally closed. Opens when you push the backlight button, adding 1.6K to the film-speed resistance.

#### DISASSEMBLY HIGHLIGHTS:

Settings: ASA 100 (to remove film-speed dial), B or M90 (to remove shutter-speed dial)

#### Sequence:

1. Nikon nameplate (2 screws)
2. bottom cover (4 screws)
3. palm grip (coin screw)
4. top cover
  - a. wind lever (loosen side setscrew and unscrew cover ring)
  - b. shutter-speed dial (retaining ring)
  - c. rewind knob, rewind shaft
  - d. film-speed dial (retaining ring) — SV brush is now loose
  - e. 6 top-cover screws (screws at sides of prism are longer)
5. lift aside top cover and unsolder 4 wires —
  - red piezo wire from FPC
  - black piezo wire from silencer switch
  - red and black X-sync wires from silencer-switch board (wires coming from shutter)
6. lift out SV brush
7. remove compensation latch, Fig. 2 (2 screws — may have washers under latch)
8. remove FPC screw, rewind side
9. lift film-speed board and remove

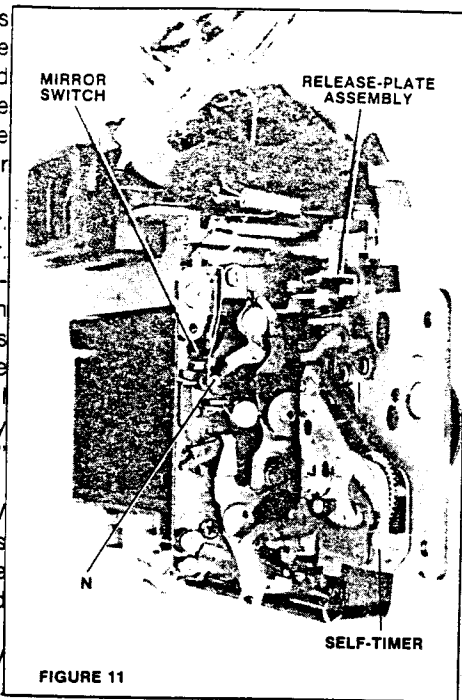

FIGURE 11

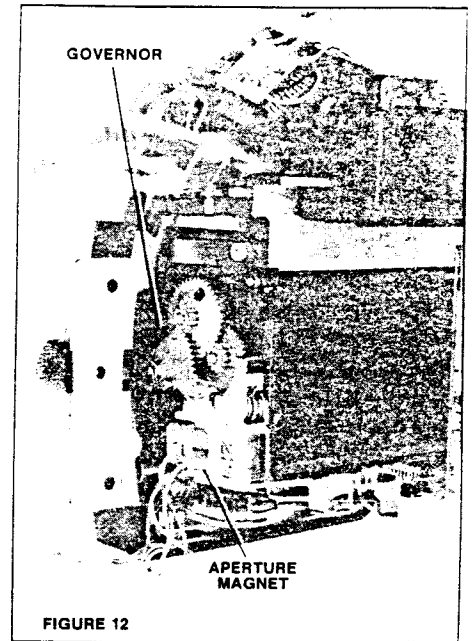

FIGURE 12

- backlight switch
10. unsolder black and yellow film-counter-switch wires from shutter-speed TV board, Fig 2
11. remove speed-dial detent spring (1 screw)
12. remove remaining screw holding TV board
13. remove E-clip under auto latch
14. lift TV board from release assembly, Fig. 6
15. disconnect spring for E-M switch, Fig. 6
16. remove E-M switch and spring
17. remove 2 flex-connector screws, Fig. 6
18. desolder 6 flex-connector solder connections, Fig. 6, to free FPC from shutter flex
19. remove plastic support plate under wind side of FPC, Fig. 8 (1 screw)
20. remove self-tapping screw holding hot-shoe contact assembly
21. unsolder red (positive-battery) wire from FPC, rewind side
22. unsolder green and brown flash-SPD wires from corner of HIC, Fig. 22
23. remove battery holder and battery-box ground ring
24. peel off light-trap porous-plastic strip, bottom of camera
25. unsolder orange program-switch wire from contact (near motor-drive phase switch)
26. unsolder all wires, bottom of FPC, Fig. 18
27. remove screw at bottom of FPC

28. remove self-timer lever (1 screw under leather disc)
29. remove right and left front leather
30. remove plate at rewind end of camera body (3 screws)
31. remove 2 upper mirror-box screws (white screws near eyepiece)
32. remove 4 front-plate screws
33. lift SV (ASA) board to clear rewind-shaft assembly
34. lift out front-plate/mirror-box assembly

#### Reassembly highlights:

1. Cock the shutter and the mirror before replacing the mirror box. To cock the shutter, push the transport latch, Fig. 9, against its spring tension.
2. Hold the mirror-box/front-plate assembly down and toward the rewind side of the camera as you tighten the front-plate screws.
3. As you seat the speed-selector assembly (TV board), Fig. 6, make sure the tab of the speed-setting shaft passes into the cutout in the plastic mechanical-speed cam.
4. To replace the shutter-speed dial, feed the slot on its underside over the upturned tab on the speed-coupling gear. Also seat the tab in the center of the shutter-speed dial into the slot in the speed-setting shaft. Hold

aside the speed-dial detent spring to fully seat the shutter-speed dial.

5. Seat the wind lever by positioning the front side first. Fit the wind-lever tab into the cocking-shaft slot.

Sequence to remove shutter:

1. unsolder leads of release-button switch from shutter flex, Fig. 9
2. remove release-button switch (1 screw)
3. remove release slide and spring (2 shoulder screws)
4. remove screw accessible through hole in side of sprocket
5. lift out rewind button and spring
6. remove wind seat (3 screws — minus-head post screw goes to front)
7. remove sprocket shaft and sprocket (loose washer on upper end of sprocket)
8. unsolder yellow and pink wires from shutter flex
9. unsolder black and blue wires from MD phase switch
10. remove shutter (3 screws — 2 at top of blade assembly and notched screw at back of aperture that also serves as ground contact for data back)

Sequence to replace shutter and wind seat:

1. Seat the shutter from the top of the camera body. Replace the three screws, and resolder the pink and yellow wires.
2. Time the wind seat before installation. First advance the wind lever until the transport latch drops into the notch in the transport cam, Fig. 14.
3. Turn the mechanical-speed cam to the bulb setting, Fig. 8 (the mechanical-speed lever can then move away from the shutter block — the mechanical-speed lever must pass to the wind-lever side of the white plastic lever at the top of the shutter block, Fig. 8).
4. Position the counter-advance gear until the pie-shaped cutout faces away from the counter dial, Fig. 8. The pie-shaped cutout should be facing the cutout in the wind seat for the back-sensing lever.
5. Turn the wind shaft so that the

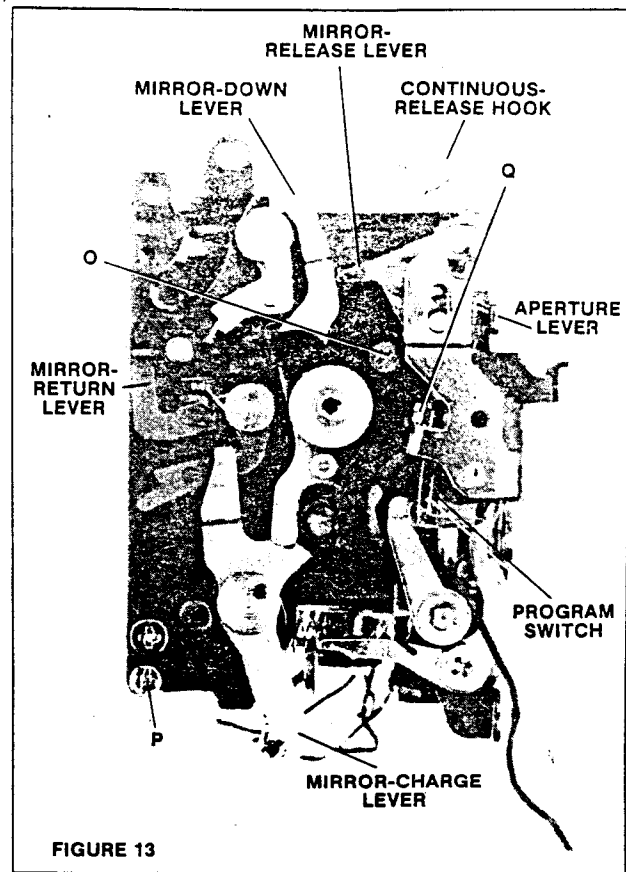

FIGURE 13

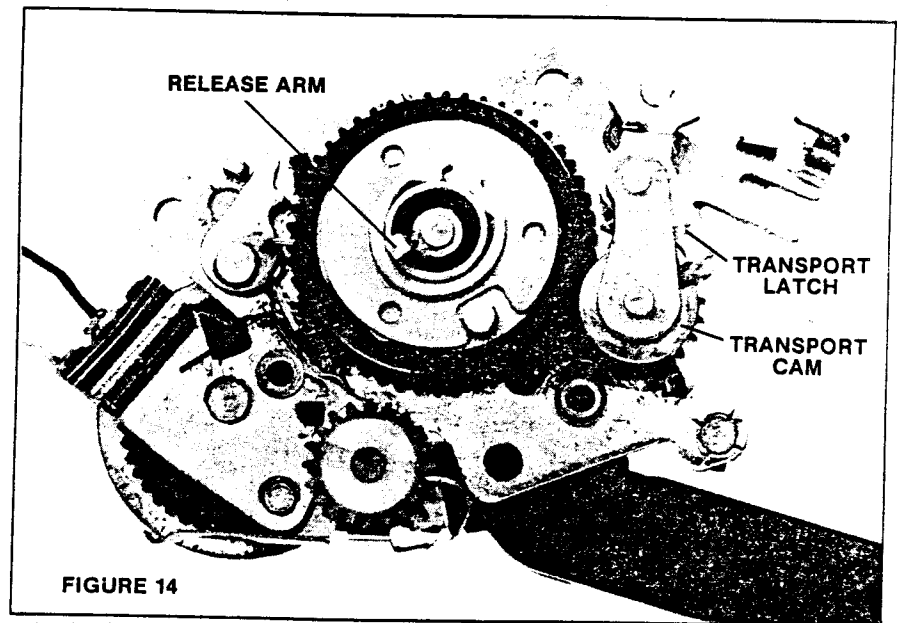

FIGURE 14

slot in the motor-drive coupler is parallel to the back of the camera, Fig. 3. Make sure the motor-drive phase switch is in the off position. If both contacts of the motor-drive phase switch are on the contact, rotate the wind shaft 180 degrees.

6. Seat the sprocket.
7. The pinion at the top of the sprocket shaft has a scribe mark on one side. Seat the sprocket

shaft in the wind seat with the scribe line facing the rivet at the center of the transport cam, Fig. 14.

7. Position the downward-projecting tab of the release arm, Fig. 14, toward the front of the wind seat. The tab must pass into the cutout area of the camera body (above the release slide).
8. Disengage the transport latch and advance the wind lever. Hold

the wind lever partially or fully advanced as you install the wind seat.

9. Replace the wind-seat screws. Seat the rewind button and spring — the square cutout around the screw hole of the rewind-button shaft should face the back of the camera. Slowly advance the wind lever until the hole in the sprocket aligns with the hole in the rewind-button shaft and replace the screw.
10. Check the timing —
  - a. Advance the wind lever fully to check the sprocket timing. Then turn the sprocket toward the rewind end of the camera to take up backlash. The right-hand edge of the sprocket tooth facing the back of the camera should now be  $27.6 \pm 0.4\text{mm}$  from the lead edge of the aperture. If not, the sprocket shaft is incorrectly timed.
  - b. Check the slot in the motor-drive coupler, Fig. 3 — the slot must be parallel to the back of the camera with the motor-drive phase switch in the off position.
  - c. Assure that the mechanical-speed lever is at the wind-lever side of the white plastic lever at the top of the shutter block, Fig. 8.
  - d. Assure that the cutout in the counter-advance gear faces away from the counter dial.

Sequence to disassemble mirror box:

1. remove lens-mounting ring (4 screws — may be washers under lens-mounting ring)
2. remove bayonet spring
3. remove AV coupling ring
4. remove front decorator plate (1 screw, bottom)
5. lift out f-value ring and spring
6. remove release-plate assembly, Fig. 11 (2 screws)
7. remove self-timer assembly, Fig. 11 (2 screws)
8. unsolder pink and black mirror-switch wires from FPC
9. remove mirror switch (1 screw)
10. remove cemented plate, bottom of mirror box (inside)
11. unsolder black program-switch wire from fo base plate, Fig. 10
12. remove 2 shoulder screws, sides of mirror box, Fig. 11 and Fig. 12
13. remove 2 screws at bottom of mirror box, Fig. 10 (the minus-

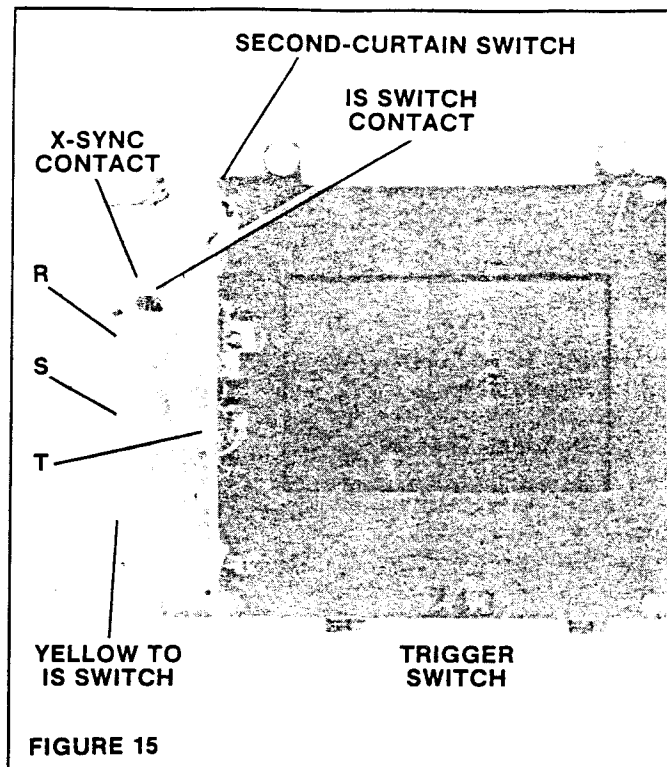

FIGURE 15

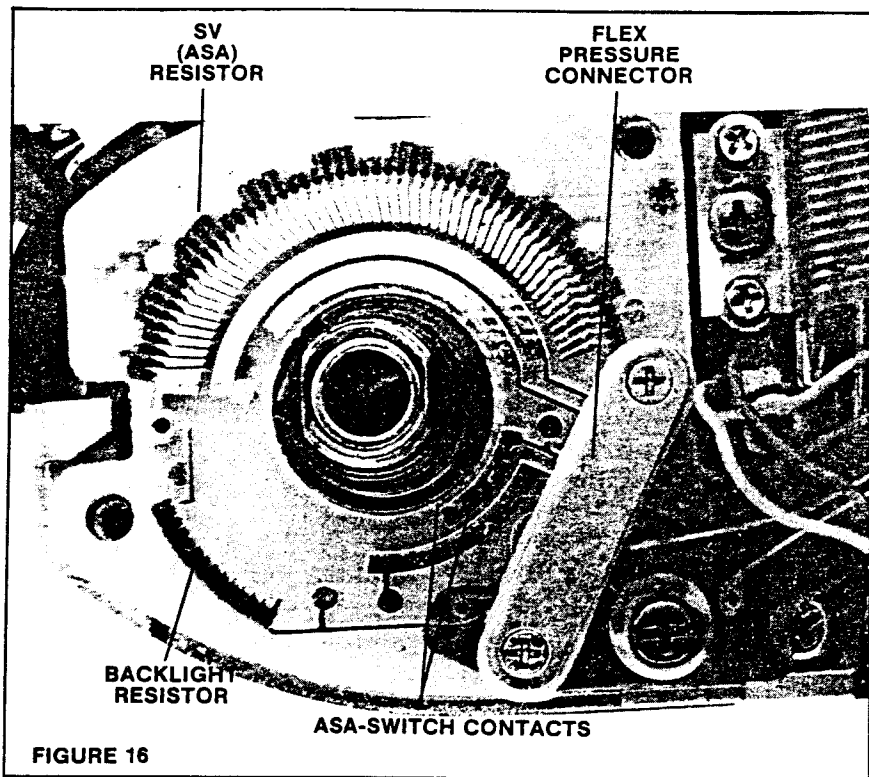

FIGURE 16

head screw goes on the wind side of the mirror box — it also serves to hook the spring for the f-value ring)

14. remove mirror box, Fig. 13
- Note: To operate the mirror box, first charge the mirror by pushing forward the mirror-charge lever, Fig. 13. To release the mirror, hold the continuous-release hook, Fig. 13,

toward the front of the mirror box. Then push up the mirror-release lever, Fig. 13. Return the mirror by pushing down the mirror-return lever.

Reassembly highlights:

1. When you replace the release-plate assembly, Fig. 11, pass the

fork of the continuous lever over the fork in the continuous-release hook, Fig. 13. Also make sure that the end of the release-charge lever (part of the release-plate assembly) fits to the front of the mirror-down lever, Fig. 13.

2. Before replacing the front-plate mirror-box assembly in the camera body, check the timing of the mirror switch (see "Switch Adjustments").

#### Sequence to remove FPC:

1. remove 2 screws holding resistor board, Fig. 1
2. unsolder pink and blue wires (f-value resistor) from FPC
3. remove screw holding LED display (center screw — do not disturb adjustment screws), Fig. 2
4. disconnect and remove 2 spring clips holding FPC, 1 on each side of pentaprism

Note: First disconnect the ends of the spring clips closer to the back of the mirror box. Then slide out the spring clips.

5. remove FPC

#### Reassembly highlights:

1. The upturned ends of the spring clips go to the front of the mirror box. These ends should point up and hook under the notched lugs of the focusing-screen frame. Seat the FPC. Then install the spring clips. First hook the front end of a spring clip under the notched lug. Then route the spring clip above the brass tab at the underside of the FPC. Finally flex the spring clip to connect the rear end.
2. Be careful to avoid overtightening the screw that holds the LED display — too much pressure will bend the display. After replacing the FPC and connecting the wires, you can check the position of the LED display (see "Adjustment Procedures").

#### BASIC CIRCUIT OPERATION:

1. The circuit uses two IC's, both on top of the FPC (flexible printed circuit) — HIC (hybrid IC) on the wind side and I2L (current-square logic) on the rewind side. A small hybrid on top of I2L has the capacitors and

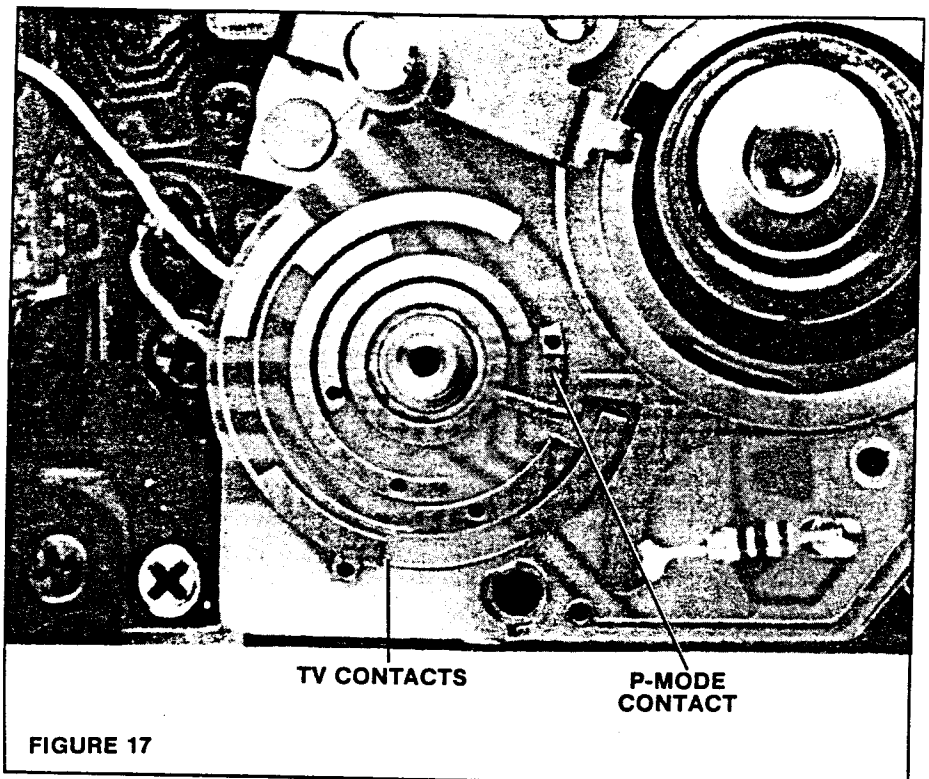

FIGURE 17

- connections for TTL flash.
2. A quartz-controlled oscillator provides the clock signal. The oscillator in HIC operates as soon as batteries are installed, allowing the quartz crystal to remain at its stable frequency (32.768KHz). But the clock signal is not applied to I2L until you depress the release button part way to close the release-button switch. The clock signal remains at I2L (pin 3) for 16 seconds after you let up the release button.
3. The E-M switch selects between mechanical and electronic operation. For the electronic settings (A, P, and manual speeds), the E-M switch connects battery voltage to the Vcc' line.
4. The Vcc' voltage appears at the anodes of the LEDs in the LED display and at the memory capacitors. When the release-button switch closes, the decoder/driver switches its outputs to 1.3V (to turn on an LED) or 1.7V (to keep an LED turned off).
5. For manual shutter speeds, the CPU counts clock pulses from the oscillator. The TV brush selects a Gray-code signal that tells the CPU in I2L what shutter speed to set. The CPU starts counting when the trigger switch (in the shutter block) opens. When the CPU reaches the proper count, it shuts off the current through the shutter magnet. Pin 40 of HIC switches high to shut off magnet current.
6. Automatic functions are timed by capacitors. On the A mode, the charge across the shutter-speed memory capacitor CMT determines the shutter speed. The CMT voltage varies according to the film-speed setting and the light level. As the diaphragm closes, the voltage of CMT decreases because the SPD sees less light. The circuit then knows the selected diaphragm opening by the final charge on CMT. The AV resistor (f-fo) here serves only for indication.
7. When the mirror rises, the mirror switch opens and locks the voltage on CMT. CMT then controls the charge time of the timing capacitor CT. When CT charges, pin 40 of HIC switches high to shut off the shutter magnet.
8. In the P mode, the circuit first selects the diaphragm opening by the charge on the aperture-memory capacitor CMA. The CMA voltage varies according to the light level and the film speed. The setting of the AV resistor (f-fo) also affects the voltage on the

aperture-memory capacitor CMA. However, this value would normally be fixed; the diaphragm should be set at the smallest aperture.

9. As the diaphragm starts to close, the program switch closes. The decreasing voltage as the SPD sees less light tells the circuit how far the diaphragm has closed. When the diaphragm reaches the proper f/stop, pin 14 of HIC switches low. Transistor Q1 then turns on, allowing capacitor CA to discharge through the aperture magnet. The hybrid aperture magnet repels its armature to arrest the aperture lever.
10. To determine the shutter speed in the P mode, the circuit compares the CMA voltage with the CMT voltage.
11. A second silicon photodiode, this one at the bottom of the mirror box, reads the flash reflected from the film for TTL control. The flash unit sends a signal through the monitor contact, Fig. 4, that tells the circuit there's a TTL flash installed. A signal through the ready-light contact, also from the flash, switches the circuit to the flash speed (1/90). When the flash has charged, the ready-light signal also turns on the ready-light LED in the display.
12. When the X-sync contacts close to fire the flash, the IS switch opens. Opening the IS switch allows a flash-timing capacitor to discharge. The discharge rate of the capacitor is compared to the increasing voltage output of the flash-SPD amplifier. When the voltages intersect, the circuit applies a signal to the TTL contact that shuts off the flash.

#### TROUBLESHOOTING:

Behavior without batteries: Mirror locks up (shutter doesn't release) on electronic speeds.

Note: Any malfunction that prevents current from flowing through the shutter magnet causes the mirror to lock up on all but bulb and M90 settings. The mirror moves to the raised position, but the shutter doesn't release. To release the shutter and return the mirror, set the mechanical speed (M90)

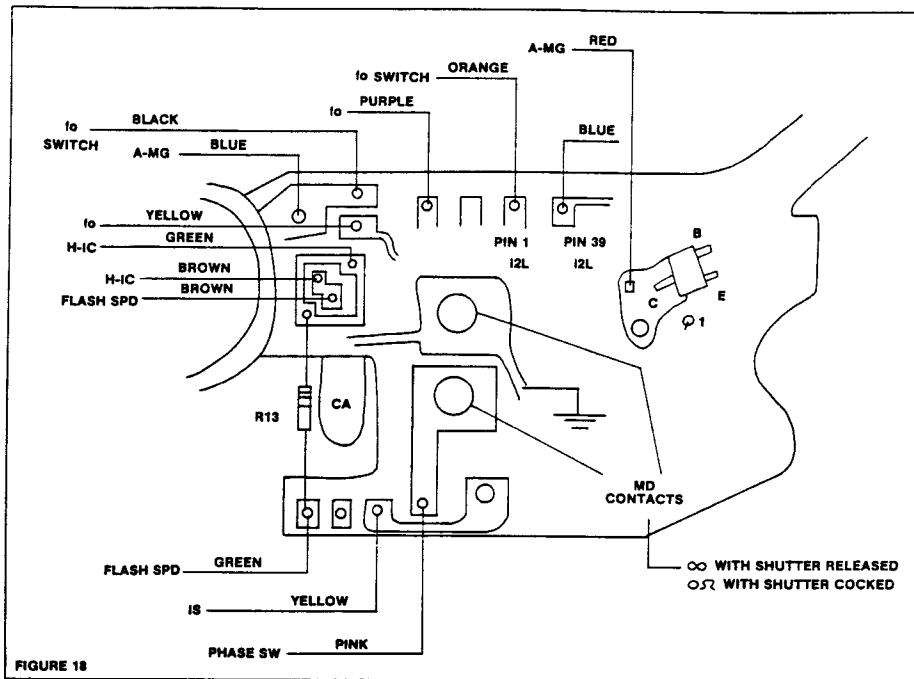

#### Current draw:

- leackage — no more than 4 microamps
- Leds on — 6ma
- shutter open — 13ma

#### Tips for troubleshooting without dis-assembly:

1. A defective program switch causes the shutter to deliver only the mechanical speed and the diaphragm to stop down fully (P mode). Check by watching the LED display as you release the shutter. The LEDs should turn off when the mirror moves up. If not, the problem is probably in the program switch, Fig. 13.
2. A defective mirror switch normally causes the shutter to deliver only the mechanical speed. Check by watching the LED display as you cock the shutter. If the LEDs turn off during the shutter-cocking stroke, the problem is probably poor contact in the mirror switch, Fig. 11.
3. A mechanical malfunction on the wind side of the mirror box may cause improper diaphragm operation on all modes. Or the shutter may release as you allow the wind lever to return. Check the adjustment on the aperture lever, Fig. 13, both in the shutter-cocked and shutter-released positions (covered under

"Adjustment Values"). If the 3.1mm (shutter-cocked) adjustment is not correct, the tab above the aperture lever, Fig. 13, may be cracked. If so, replace side plate B5201. If the 3.5 — 3.7mm (shutter released) tolerance is not correct, the aperture lever may just be out of adjustment (possibly causing the shutter to release as soon as the wind lever is allowed to return).

4. If the customer complains of overexposure, check the diaphragm opening at high light levels (P mode). Erratic action, or too large an opening, may mean that the governor on the rewind side of the mirror box, Fig. 12, is dirty. The travel time for the governor to run from f/1.8 to f/22 should be 35ms or less. If the time is too long, the automatic control may arrest the diaphragm before the diaphragm has had time to stop down fully. It may then be necessary to replace the mirror-box side plate B5301.
5. Check the motor-drive phase switch and the second-curtain switch by measuring the continuity between the two motor-drive terminals at the bottom of the camera, Fig. 3. With the shutter released, you should measure 0 resistance. If you measure infinite resistance, the second-curtain switch may not be making contact. Partially

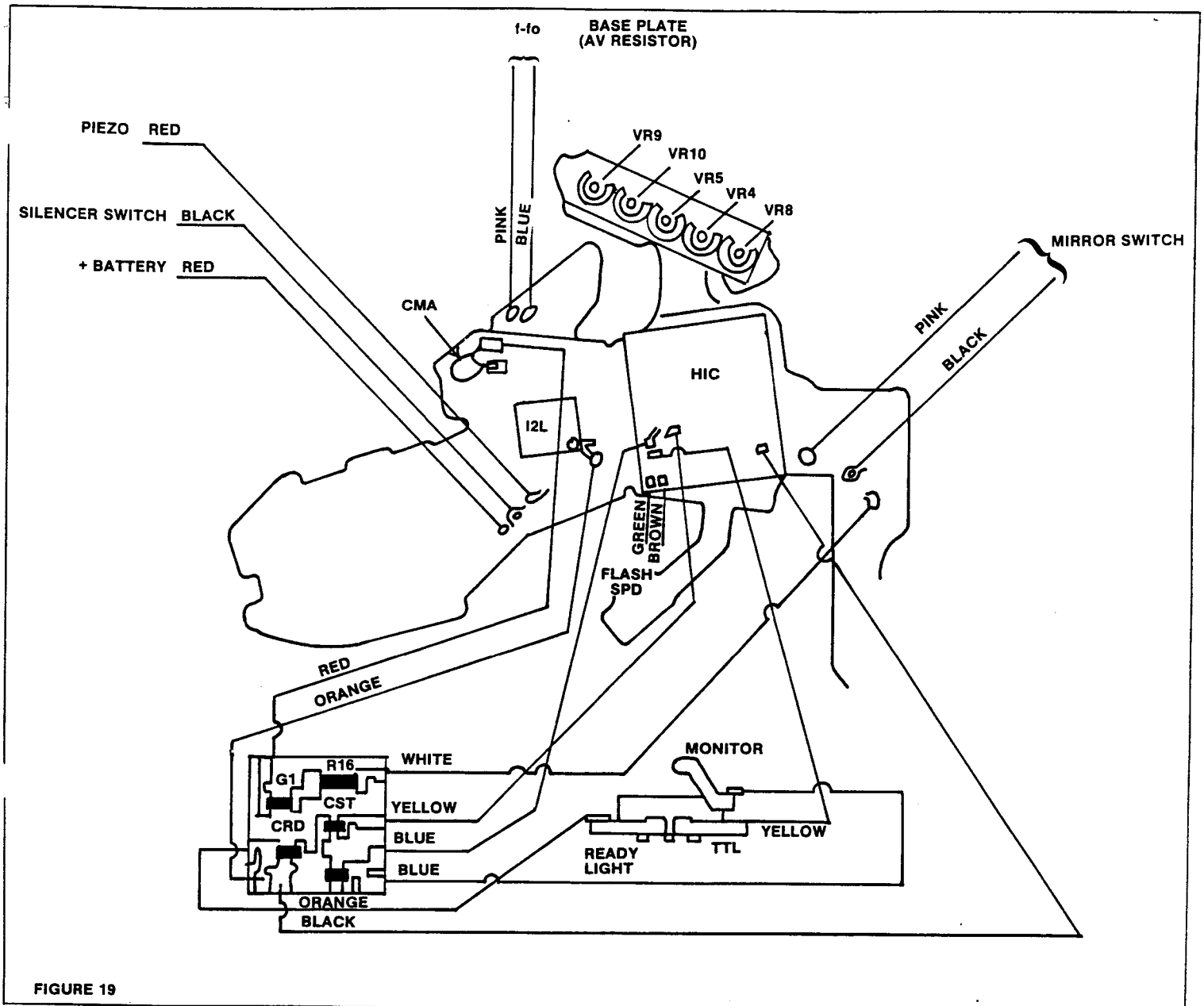

FIGURE 19

cock the shutter. You should still measure direct contact. If not, check for poor contact in the motor-drive phase switch, Fig. 3. With the shutter fully cocked, you should measure infinite resistance.

6. Check the SV and AV resistors by watching the LED display. If the LED display doesn't change when you rotate the f-value ring, the problem is poor contact in the f-fo resistor (affects only the readout). If the display doesn't change when you rotate the film-speed dial, the problem is poor contact in the SV (ASA) resistor (affects both the readout and the A and P modes).

Troubleshooting steps for specific problems:

1. Mirror locks up, no LEDs (works properly on M90 and B)  
 Battery voltage to FPC  
 Check for Vcc (battery voltage) at the red wire, rewind side of FPC, Fig. 19. No voltage — battery box or wiring.  
 E-M switch, poor contact  
 Check the Vcc' voltage (battery voltage) at capacitor CMA, Fig. 19 (red-wire connection). At any electronic setting, you should measure Vcc'. If not, check for poor contact in the E-M switch, Fig. 6. Push the release button

part way and short between lands a and b, Fig. 6. If the LEDs then turn on, the problem is in the E-M switch contacts.

Release-button switch

Short pin 18 of I2L to ground, Fig. 21. If the LEDs turn on, the IC is o.k. Check the release-button switch and the flex-connector solder connections, Fig. 7. With the release button depressed part way, you should measure direct contact between TP-A, Fig. 7, and ground. If so, the release-button switch is o.k. You should also measure direct contact between pin 18 of I2L and ground. If so, the flex-connector solder is o.k.

Program switch, shorted to ground or not opening

With the mirror locked up, check the voltage at pin 39 of I2L, Fig. 21 (should be around 0.7V). If 0V, the program switch, Fig. 13, may be constantly closed. Or pin 39 may be shorted to pin 38, Fig. 21.

Battery check voltage

Check the voltage at pin 7 of I2L, Fig. 21. The voltage should be around 0.7V. If 0V, HIC is defective or there's poor solder at pin 7 of I2L or pin 6 of HIC.

- Mirror locks up, LED's work properly

Shutter magnet

Check the voltage at the shutter-magnet test point, Fig. 4 (the test point goes to the side of the shutter magnet that connects to pin 40 of HIC). You should measure 3V. If you measure 0V, the magnet coil is open or the flex-connector, Fig. 6, has poor solder. Check the magnet between TP-B and TP-C, Fig. 7. Appropriate coil resistance — 300 ohms. If the magnet is open, replace the complete shutter block B1003.

Trigger switch, poor contact

Check with the mirror locked up at pin 21 of I2L. The trigger switch should be closed, and you should measure 0V. If you measure 1 — 2V, the trigger switch is not making contact. Check at mechanical bulb between TP-D and TP-E, Fig. 7. You should measure 0 resistance with the shutter cocked, infinite resistance with the shutter released (unless you desolder the flex-connector, you'll measure some resistance through I2L).

Mirror switch, not opening

Check the voltage at the pink mirror-switch wire, Fig. 19, with the mirror locked up. You should measure around 0.7V. If you measure 0V, the mirror switch is not opening or is shorted to ground.

FPC ground connection

Separate the FPC from the film-speed SV board (pressure connector) and clean the pressure contacts.

- Shutter delivers only fast mechanical speed (0.5 — 0.6ms) at A and P modes

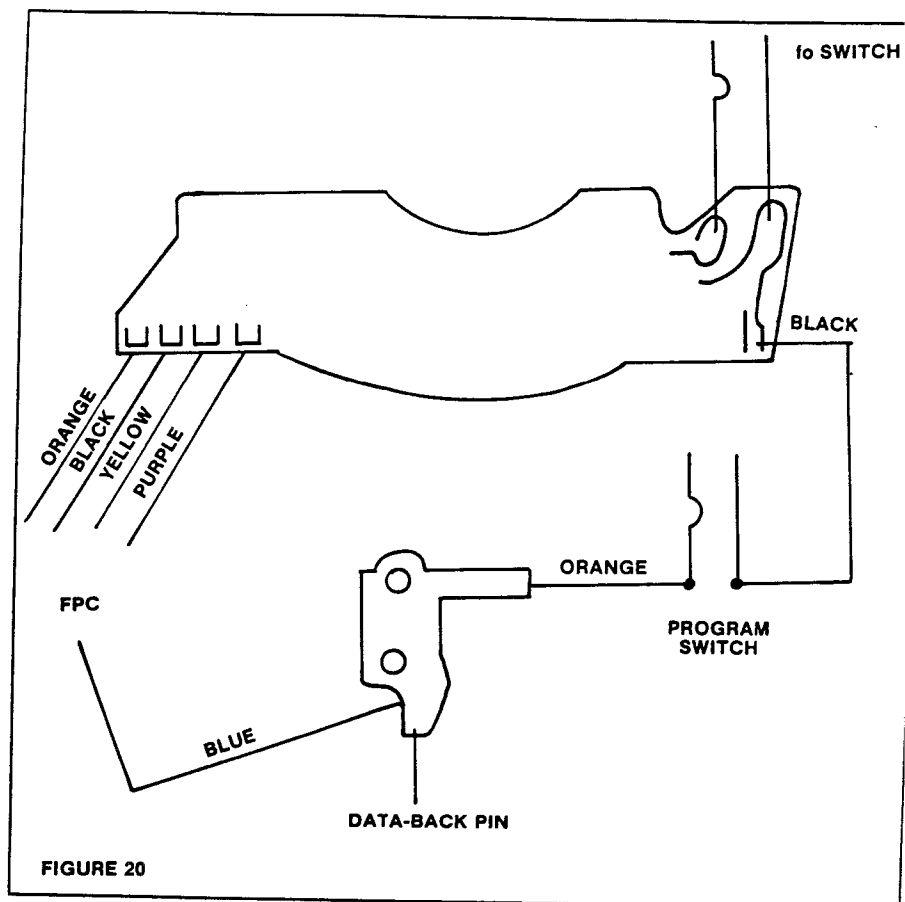

Mirror switch, poor contact

If the LEDs turn off as you cock the shutter, the mirror switch is open. Check with an ohmmeter between the pink wire, Fig. 19, and ground. You should measure direct contact with the mirror down, no contact with the mirror up.

Program switch, poor contact or chattering

Check between the orange wire to the program switch, Fig. 3, and ground. You should measure direct contact with the mirror up. To check for chattering, connect a scope between ground and pin 39 of I2L. The trace triggers at 0V (when the program switch closes). The trace here shows contact bounce or chattering. If the chattering occupies more than 10% of the total trace, it is excessive (the circuit can tolerate less than 10% chattering). For excessive chattering, clean the program switch or bend the movable contact to increase the contact pressure.

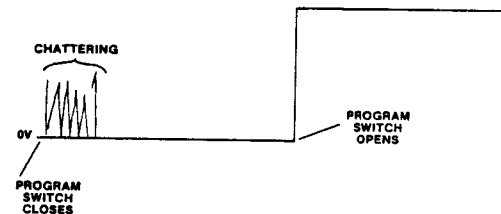

FPC pressure connector, poor contact to program switch

Check the continuity between the blue wire at the bottom of the FPC and pin 39 of I2L. You should measure direct contact. If not, take apart the pressure connector and clean the contacts (bottom and top of SV board, contacts on lower section of FPC, contacts on upper section of FPC).

- Shutter hangs open on manual speeds (or manual speeds don't agree with speed-dial setting) TV brush, poor contact or timing incorrect

Check the voltages at pins 13, 14, 15, and 17 of I2L, Fig. 21. You should measure either 0V or around 0.6V depending on the shutter-speed setting. The chart shows the proper combinations.

Setting	Pin 13	Pin 14	Pin 15	Pin 17
P	0V	0.6V	0.6V	0.6V
A	0V	0.6V	0.6V	0V
1/1000	0V	0.6V	0V	0V
1/500	0V	0.6V	0V	0.6V
1/250	0V	0V	0V	0.6V
1/125	0V	0V	0V	0V
1/60	0V	0V	0.6V	0V
1/30	0V	0V	0.6V	0.6V
1/15	0.6V	0V	0.6V	0.6V
1/8	0.6V	0V	0.6V	0V
1/4	0.6V	0V	0V	0V
1/2	0.6V	0V	0V	0.6V
1	0.6V	0.6V	0V	0.6V

5. Shutter hangs open all modes, LEDs o.k.

Oscillator defective

Check for the clock signal (32K Hz) at pin 3 of I2L with the release button partially depressed, electronic-speed setting. With a scope, you should get the signal shown at pin 3 in Fig. 21. Or a voltage of around 0.23V indicates the presence of the clock signal. If you get the proper signal, yet the shutter still hangs open, check the solder connection to pin 37 of I2L (ground). If you do not get the proper signal at I2L, check the quartz signal at the test points shown in Fig. 6 (it's not necessary to depress the release button — the quartz signal should be present whenever batteries are installed). Quartz signals:

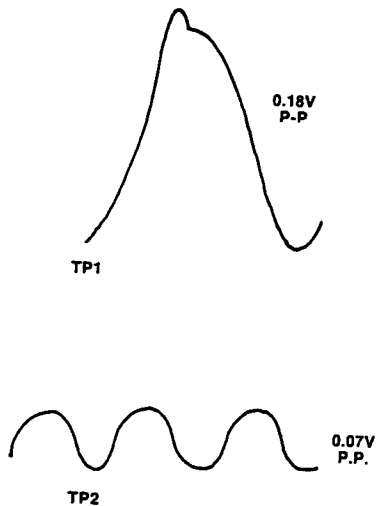

If you get distorted waveforms, check the solder connections at pins 38 and 39 of HIC. No signal indicates a defective quartz crystal.

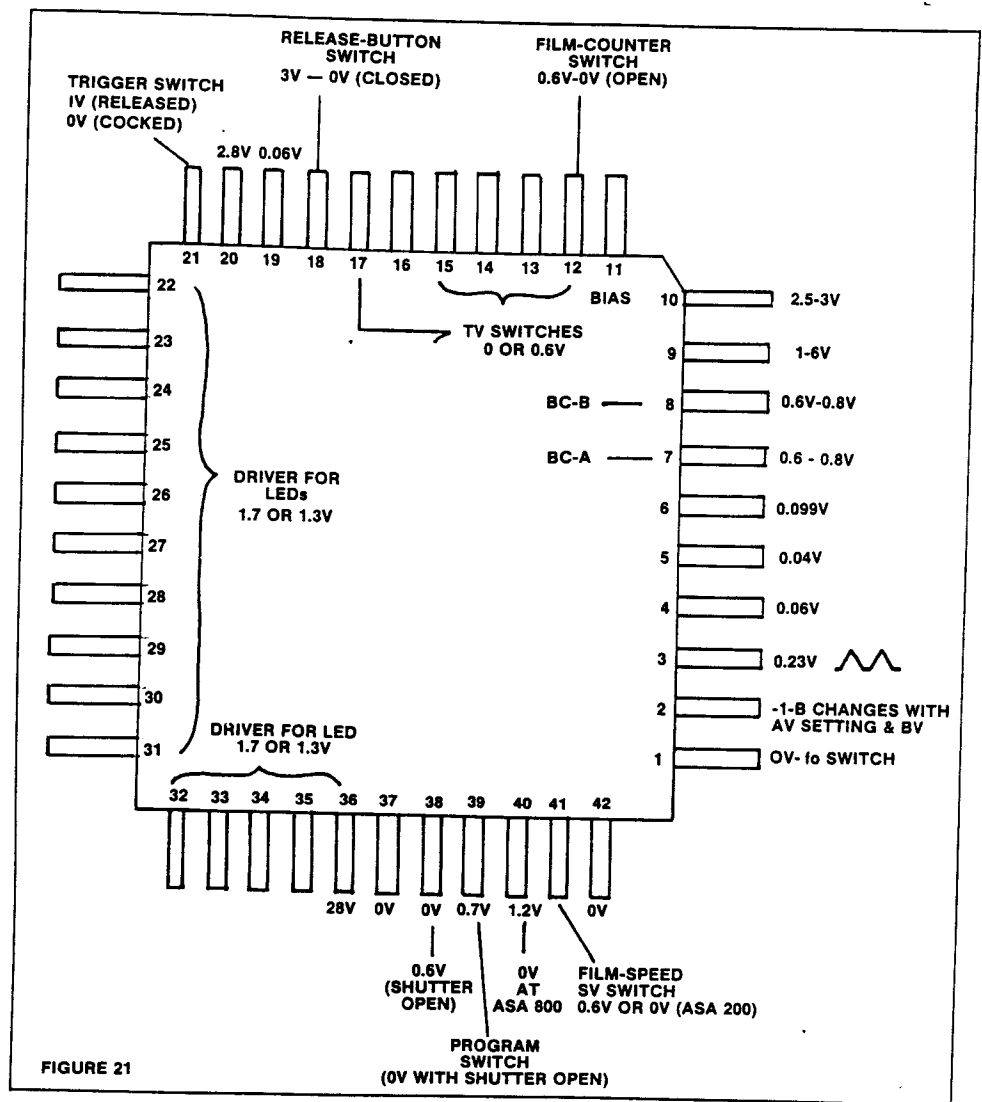

FIGURE 21

Shutter hangs open, P and A modes (manual speeds o.k.)

Shutter-speed memory capacitor CMT, open

Cock the self-timer. Then measure the voltage at the CMT test point, Fig. 5. Release the shutter. As the self-timer runs, the CMT voltage should gradually decrease. If the voltage drops immediately, CMT is open.

Timing capacitor CT, shorted

Check the voltage at the timing capacitor test point, Fig. 4. You should measure 0V. If you measure 3V, the timing capacitor is shorted.

HIC

Check the voltage at the CMT test point while changing the light striking the SPD, Fig. 5. The voltage should be around 2.3V, but it should go more positive as you increase the light. If there's

no voltage change, HIC may be defective.

SV (ASA) resistor, poor brush contact

Check brush contact if only the bottom (under) LED turns on (flickering).

VR8, poor solder

7. Diaphragm always stops down fully in P mode, shutter speeds o.k.

P-mode switch, poor contact

Check the voltage at the P-mode switch test point, Fig. 4. You should measure 0V in the P mode, 0.6V in the A mode. If you measure 0.6V in the P mode, remove the TV brush and improve the contact to the P-mode switch, Fig. 17.

HIC defective

Check the voltage at pin 13 (it's necessary to scrape away the silicone to measure the HIC pin

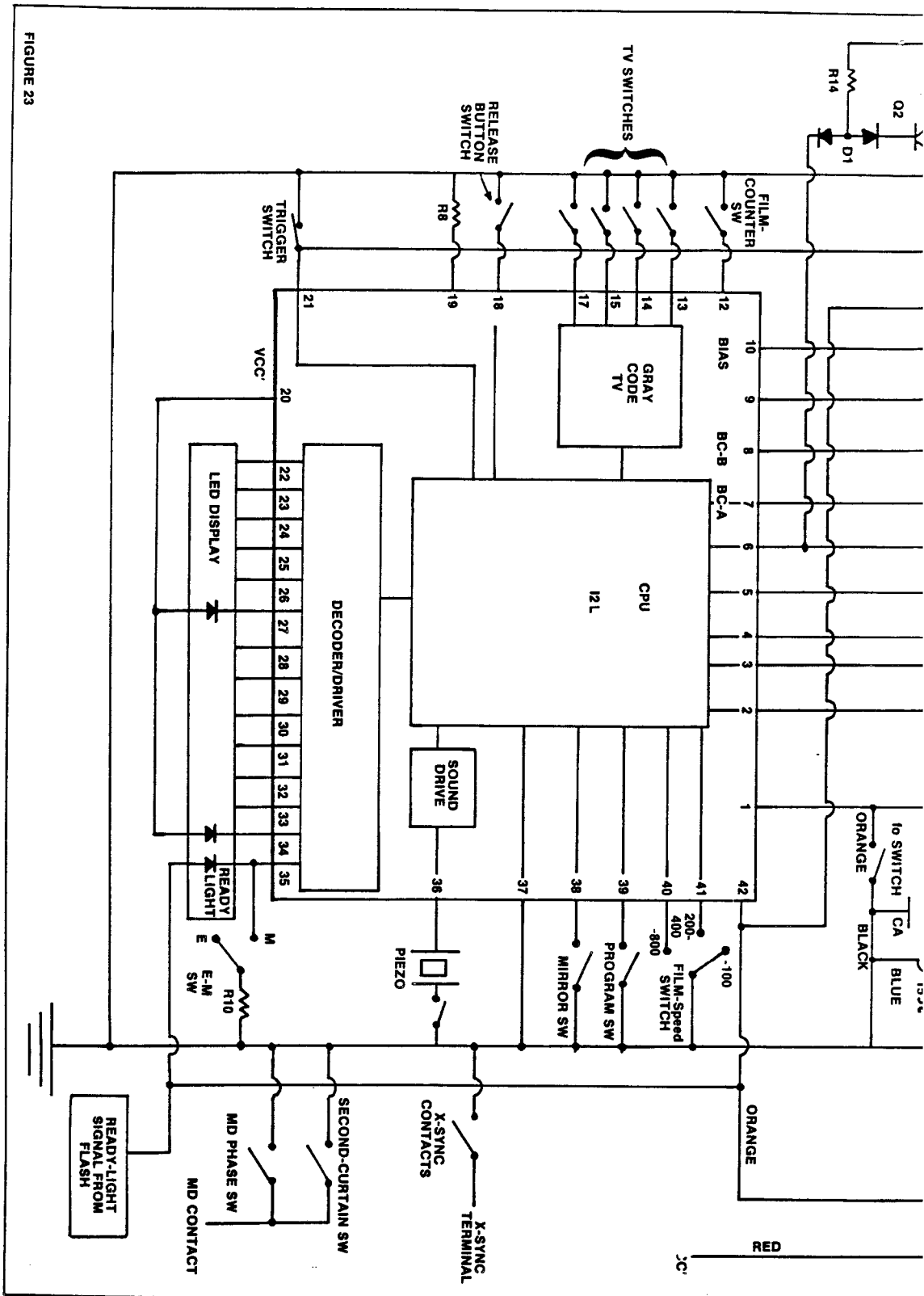
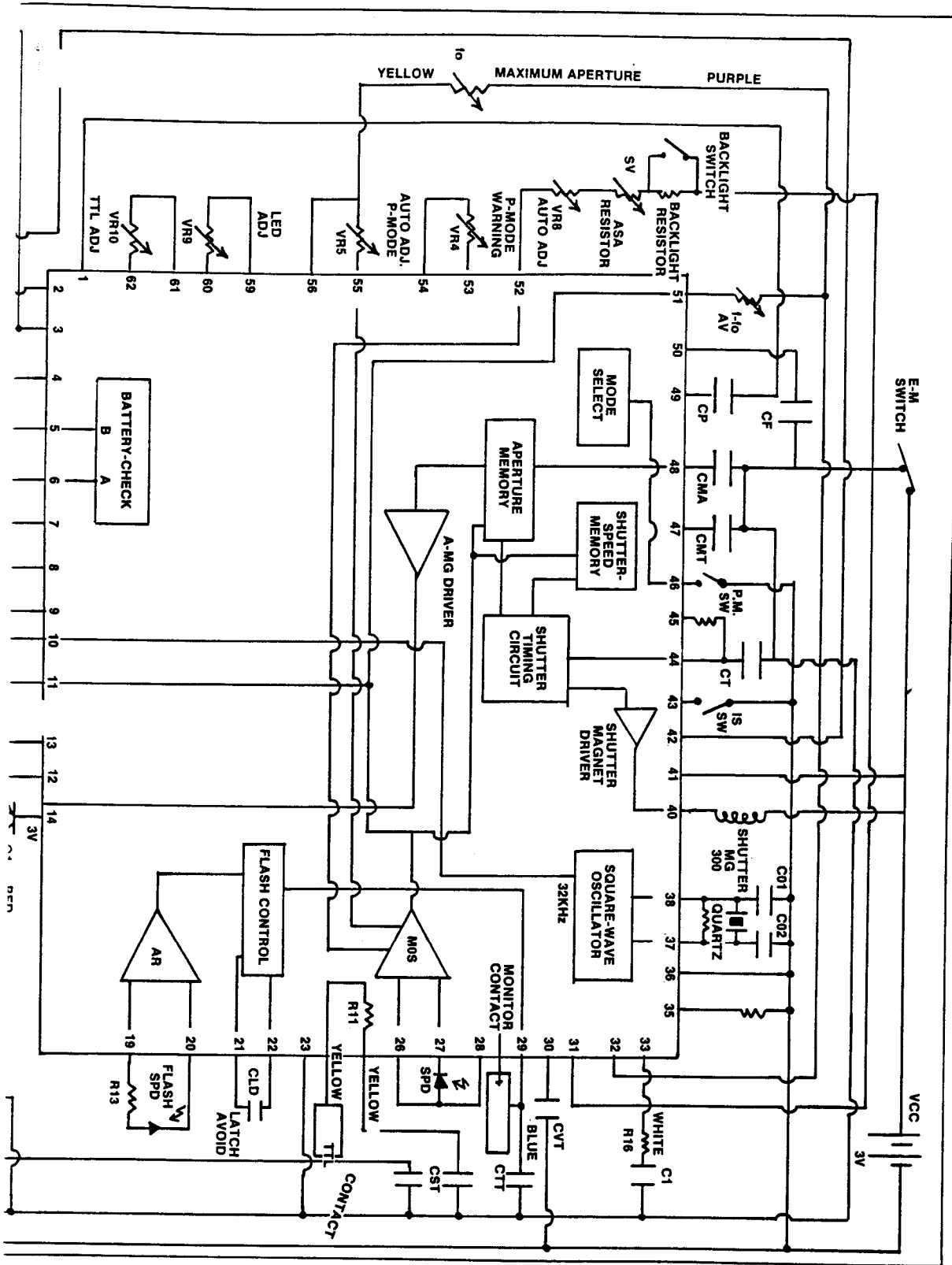

FIGURE 23



voltages). The voltage should be 3V. When you release the shutter in the P mode, the voltage should switch to 0V.

Aperture magnet, capacitor CA, or transistor Q1

Check by shorting between the emitter and collector of Q1, Fig. 18 — you should hear a click as the aperture magnet separates. When you then release the shutter, the diaphragm should remain fully open. Check the aperture magnet between the red and blue wires, Fig. 18 — approximate coil resistance is 15 ohms.

Flex pressure connector, poor contact

Disconnect the pressure connector, Fig. 16, and clean the contacts (also the contacts on the lower side of the SV board and the lower section of the FPC).

8. Diaphragm always remains fully open in P mode

Aperture magnet, not holding armature

Check to see if the diaphragm will stop down on the M90 setting. If not, the aperture magnet may be defective (not holding armature) or there may be a mechanical problem on the mirror box, Fig. 12.

fo resistor, poor contact

Measure the resistance between the purple and yellow wires, Fig. 18, to the fo resistor. You should measure around 3.5K with no lens. The resistance should change as you push the maximum-aperture lever toward the rewind side of the camera. If open, remove the mirror box to clean fo, Fig. 10, and improve the brush contact.

Aperture-memory capacitor CMA, shorted

Measure the voltage at the CMA test point, Fig. 5. You should measure around 2 — 2.6V — the voltage should increase as you increase the light level. If you measure 3V, CMA is shorted. If the voltage does not change, HIC may be defective.

Flex pressure connector, poor contact

Check the continuity between

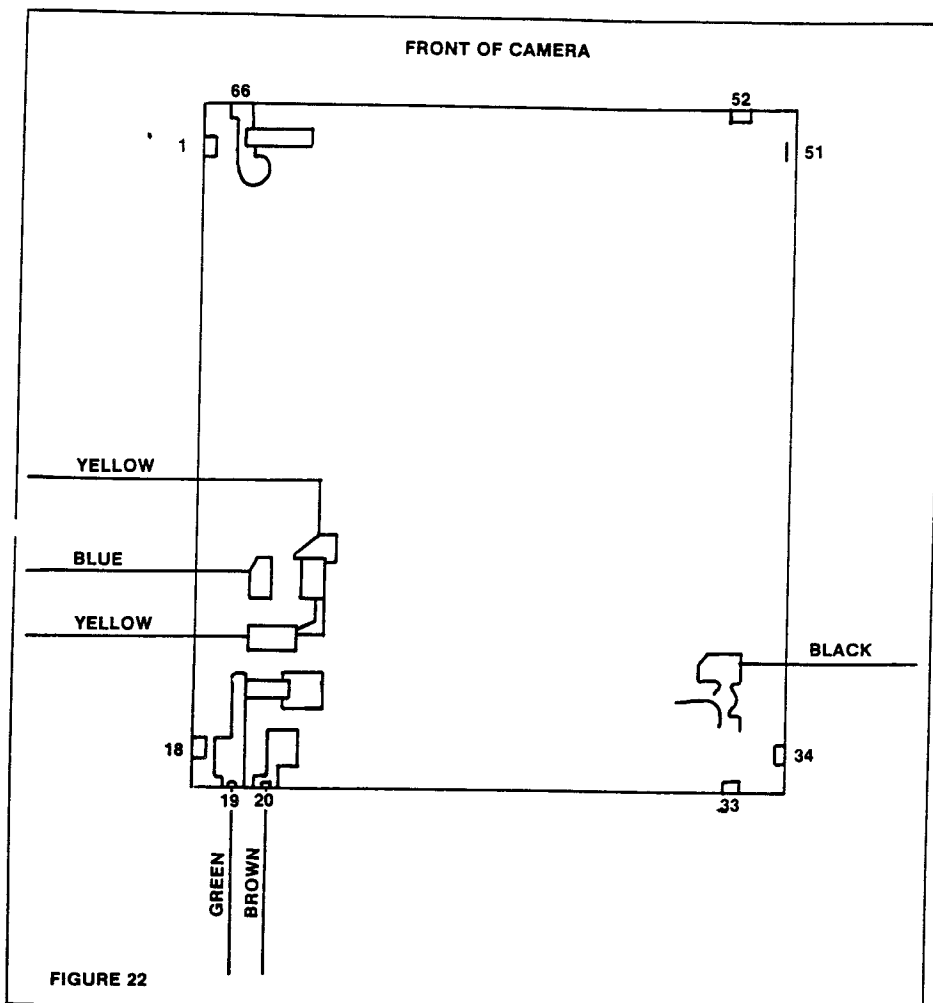

FIGURE 22

the orange wire, bottom of FPC, and pin 1 of I2L. No continuity — disconnect the pressure connector, Fig. 16, and clean the lands.

VR4, Fig. 19 — poor solder

VR5, Fig. 19 — poor solder

9. Only the bottom (under) LED turns on (flickering) in A and M modes, shutter o.k.

f-fo resistor, poor contact

If the P-mode warning signal also fails to operate, check the f-fo resistor. Short between the pink and blue wires at the front of the FPC. If you then get a shutter-speed reading in the A mode — or the P-mode warning signal in the P mode (under and over LEDs flashing alternately at f/11 or larger) — the f-fo resistor has poor contact. Approximate resistance between pink and blue wires — 0 ohm (no lens) to 6.9K (f-value ring turned fully). The resistance should change 0.9K per AV.

10. Only the bottom (under) LED turns on (flickering), P and A

modes

VR9, Fig. 19 — poor solder  
HIC, defective

Check the metering input to pin 2 of I2L. The voltage should change as you change the diaphragm setting or the light level. If not, HIC may be defective.

11. Excessive battery drain

Capacitor CA, Fig. 18

Check the current draw with the shutter-speed dial at bulb or M90 (E-M switch off). You should measure no more than 4 microamps. If you measure more than 4 microamps but less than 1ma, CA may be leaking. If you measure over 1ma, CA may be shorted to ground.

HIC, defective

PART NUMBERS:

FPC — B5001 (1B060-066-4)

Shutter — B1003 (1B060-029)

Mirror-box side plate (mirror-operating side) — B5201 (1B001-172)

Mirror-box side plate (A-magnet side) — B5301 (1B060-049-1)

f-fo base plate — B364 (IS007-017)

Aperture magnet — B327  
(1B001-119)

Battery box — B111 (1B001-143)

**OTHER COMMENTS:**

1. You can't buy individual components for the FPC. However, if you replace the FPC, save the old one. You can separate the two sections of the FPC (pressure connector). The lower section of the FPC contains the capacitor CA and the transistor Q1 for the aperture magnet. Since the SV (ASA) resistor can't be purchased separately, you can also use this part from a defective FPC.
2. The Seiko shutter is supplied only as a complete unit (including the shutter flex).
3. You can drop out the focusing screen for cleaning from inside the mirror box. Remove the screw and plate at the top front of the lens opening.

## VLC-1 Calibrated Light Source

First Member of the VLC\* Family

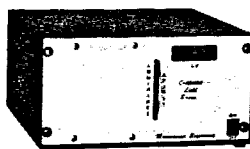

- Wide Light Range
- Digital Display
- Low Cost

- Continuous luminance coverage with thumb-wheel control from LV 6 to LV 15 in one range, with .1 LV resolution digital display
- DC powered lamp, 1000-hour life
- Excellent performance to cost ratio
- 2-year warranty
- Price: \$588
- Write for brochure

\*Very Low Cost.

**Measurement Engineering**  
Post Office Box 1689 Lowell, Mass. 01853  
617-646-0463

## Hard-To-Find Camera Parts

From out-of-production and junk cameras

Find more than 20,000 items a month in the 108 or more, big 11x14 pages. Individuals selling used or broken cameras from all over the U.S. at bargain prices. Subscribers pay only 12 cents per word for classified ads in this nationwide marketplace for anything photographic.



**shutterbug ads**

P.O. Box F-121  
Titusville, FL 32780

**SPECIAL GET ACQUAINTED OFFER**

Yes, I Want To Get The Best Deal! Enter my subscription to the national photo equipment shopper, Shutterbug Ads, today. If I'm not 100% satisfied with my first issue, my money will be refunded in full. But I keep that first issue. It's my FREE sample.

Mail my 13 issues (12 regular issues, plus one FREE sample) Bulk Rate @ \$10.00 a year.

I want first crack at the bargains. Mail my 13 issues First Class @ \$35.00 a year.

Name \_\_\_\_\_

Address \_\_\_\_\_

City \_\_\_\_\_ State \_\_\_\_\_ Zip \_\_\_\_\_

MASTERCARD & VISA Orders phone TOLL FREE 1-800-327-9920

Mail to: SHUTTERBUG ADS, P.O. BOX F-121, TITUSVILLE, FL 32780