

IMPORTANT!

F M

INFORMATION

A REVISED EDITION OF REPAIR MANUAL FOR THE NIKON FM

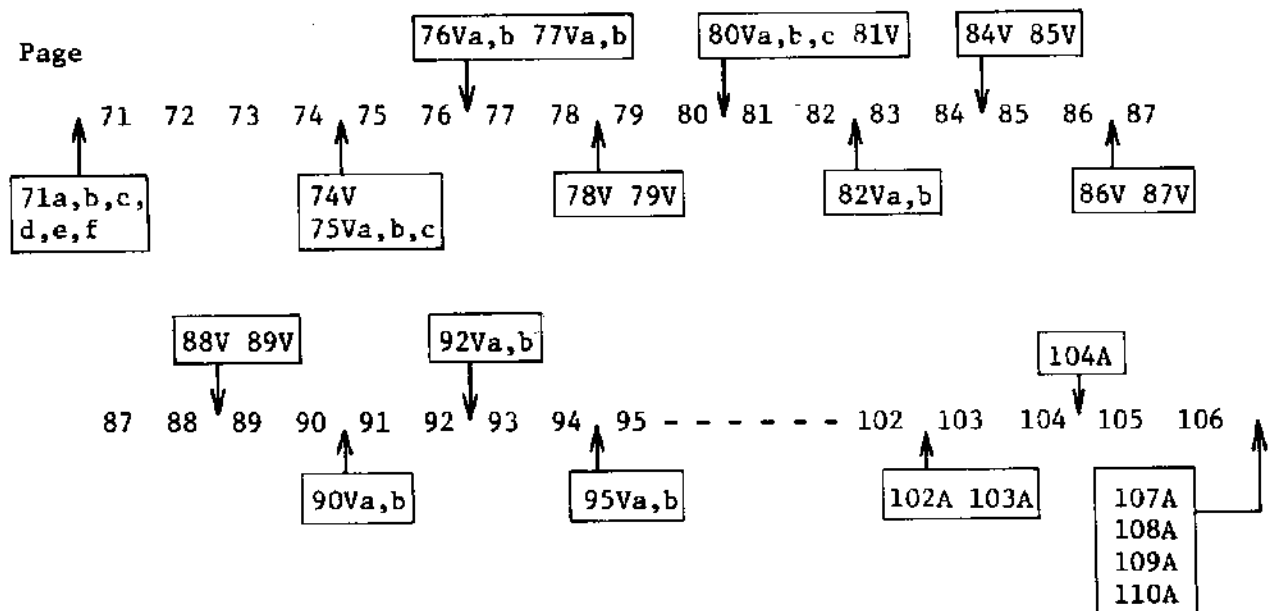
Due to the considerable amount of the internal mechanism parts change, the repair manual is revised.

A set of the revised edition is as follows:

- 1) a binder
- 2) Parts control cross reference list (Page 1 - Page 34) ----- yellow
- 3) Parts and subassembly list (Page 5 - Page 31g) ----- white, green & pink
- 4) Drawings and parts list (Page 35 - Page 66) ----- white
- 5) Disassembly sequence (Page 71a - Page 71f) ----- pink
- 6) Reassembly and adjustment (Page 74V - Page 95Vb) ----- pink
- 7) Reassembly and adjustment, supplement (Page 102A - Page 110A) ----- orange

Combine the revised edition with your repair manual as follows:

- 1) Replace the binder with a new one
- 2) File the Parts control cross reference list before Page 5 of the Parts and subassembly list
- 3) Replace the Parts and assembly list
- 4) Replace the Drawings and parts list, except the specification and the figure of external
- 5) File the Disassembly sequence, the Reassembly and adjustments, and the Reassembly and adjustment, supplement in order as below.



Note: the Parts list consists of three sections

- i) 33FB (Page 7 - Page 17, white) ----- Parts used for the old and new FM
- ii) P33FB (Page 17a - Page 31f, green) ----- Parts used for the old and new FM/FE

iii) 35FB (Page 3lg, pink) ----- Parts commonly used for the old FM/FE,
but exclusively used for the new FE.

Use care not to order parts directly in reference to the parts numbers on the
pages of the Reassembly and adjustment. Check parts numbers against the Parts
list and the Parts control cross reference list before each order.

IMPORTANT!

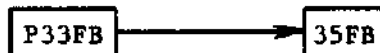
INFORMATION FOR THE EFFICIENT PARTS CONTROL AFTER THE MODIFICATION,
EFFECTIVE JULY 1979

The parts supply for the Nikon FM/FE has been/will be carried out under the classification of product codes 33FB, 35FB and P33FB. However, since the modification assures no interchangeability between new and old parts, with some exceptions, it increases the number of parts to be ordered and stocked. Additionally, the modification varies the extent of common usage of parts and thus some parts change the product code from 33FB/35FB (P33FB) to P33FB (33FB/35FB).

Under these circumstances, be sure to arrange the parts orders for 33FB, 35FB and P33FB with careful attention to the change of product code and parts number, and verify the inventory of yours for preventing an excessive order.

The change of commonly used parts falls into the following three cases;

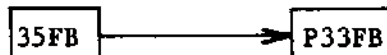
- i) A part commonly used for the old FM/FE will be used exclusively for the new FE, since simply the FM has been modified.



- ii) A part commonly used for the old FM/FE will be used exclusively for the new FM, since simply the FE has been modified.



- iii) A part exclusively used for the old FE will be used commonly for the new FM/FE, since the FM has been modified.



As mentioned above, an old part cannot be replaced with a modified one in principle. But there are some exceptions as follows;

33FB #490-5 Multi-exposure arm A
B26-6 Mirror holder

35FB #240-5 Screen lock spring
#490-1 Multi-exposure lever
#651-1 Rewind shaft bearing
B-5 Front plate

P33FB #202-5 Bayonet
#496-6 Sprocket stopper spring
#848-1 Eyelet set screw
A2-1 Eyelet
A6-5 Charge lever
A12-6 Sprocket stopper

These new parts can be used also in the old camera body.

The modification will cause a complex situation for the parts control of the FM/FE, due to the considerable amount of modified parts and the changes of commonly used parts. For preventing troubles of parts order at the initial stage, the following Parts Control Cross Reference List is prepared to show at sight how a part is used in the old and new FM/FE, including the parts which have not been modified.

Also note that there are some UNMODIFIED parts which have been simply changed their part numbers with the modification. Thus, take care to use the new number for every part when placing on order.

Therefore, it is indispensable for the parts control that the part numbers and product codes of spare parts in your stock should be changed as soon as possible, against the cross reference list.

How to read the Parts Control Cross Reference List

A) Unmodified parts

	Parts number	New FE	Old FE	New FM	Old FM
ex. 35FB	653	X	X		
33FB	39			X	X
P33FB	53	X	X	X	X

B) Parts exclusively used in the old body

ex. 35FB	K		X		
33FB	53				X
P33FB	25-1		X		X

C) Parts exclusively used in the new body

ex. 35FB	K-6	X			
33FB	470-6			X	
P33FB	25-2	X		X	

D) Change of commonly used parts: Case i)

ex. 35FB	470-5	X	X	X	
----------	-------	---	---	---	--

E) Change of commonly used parts: Case ii)

Parts number	New FE	Old FE	New FM	Old FM
ex. 33FB 217-5		X	X	X

F) Change of commonly used parts: Case iii)

ex. P33FB 283-5	X	X	X	
--------------------	---	---	---	--

G) Change Product code or Parts number

ex. 33FB B16				
B16-5			X	X

Parts number	New FE	Old FE	New FM	Old FM	Remarks
39			X	X	
40			X	X	
52			X	X	
53				X	
56			X	X	
57			X	X	
61			X	X	
67-1			X	X	
68(01)			X	X	
68(02)			X	X	
76			X	X	
78			X	X	
79-1			X	X	
80				X	
80-6			X		
81			X	X	
83				X	
87			X	X	
90				X	
151				X	
152			X	X	
155			X	X	
155A			X	X	
160			X	X	
161			X	X	
162				X	

Parts number	New FE	Old FE	New FM	Old FM	Remarks
163			X	X	
164				X	
175			X	X	
176				X	
177			X	X	
178			X	X	
201				X	
201-6			X		
210A-5			X		
217-5		X	X	X	Change Product cord from P33FB-217-1
221-1			X	X	
222-1				X	
222-6			X		
232			X	X	
233			X	X	
237			X	X	
250				X	
251				X	
252				X	
252-6			X		
253			X	X	
262-5			X		
264-5			X		
266-5			X		
267-5			X		
268-5			X		

Parts number	New FE	Old FE	New FM	Old FM	Remarks
282				X	
283-1				X	
284				X	
291-5		X	X	X	Change Product cord from P33FB-291
291A-5		X	X	X	Change Product cord from P33FB-291A
291B-5		X	X	X	Change Product cord from P33FB-291B
302			X	X	
303			X	X	
313				X	
314				X	
314-6			X		
320			X	X	
321A			X	X	
321B			X	X	
321C			X	X	
329			X	X	
331-5		X	X	X	Change Product cord from P33FB-331
334				X	
336				X	
339-5		X	X	X	
342-1				X	
343-1				X	
343-6			X		
348			X	X	
349			X	X	
355A				X	

Parts number	New FE	Old FE	New FM	Old FM	Remarks
357-5		X	X	X	Change Product cord from P33FB-357
361			X	X	
367				X	
368				X	
374				X	
374-6			X		
378				X	
404A			X	X	
406-1		X	X	X	Change Product cord from P33FB-406
468-1(01)				X	
468-1(02)				X	
468-6			X		
468-6 (Black-finished)					Order 35FB-468
470-6			X		
476				X	
478-1				X	
490				X	
490-5			X	X	
490A			X	X	
491(01)			X	X	
491(02)			X	X	
492				X	
492-6			X		
493B			X	X	
494			X	X	
494A				X	

Parts number	New FE	Old FE	New FM	Old FM	Remarks
503			X	X	
518A			X	X	
519			X	X	
527-1			X	X	
535C				X	
535D				X	
540B				X	
541-2			X	X	
541A			X	X	
542-2			X	X	
543-3			X	X	
571			X	X	
575-2(01)			X	X	
575-2(02)			X	X	
576			X	X	
577-2			X	X	
578-1			X	X	
579			X	X	
581			X	X	
588				X	
588-6			X		
589				X	
589-6			X		
590				X	
590-6			X		
594				X	

Parts number	New FE	Old FE	New FM	Old FM	Remarks
596			X	X	
600			X	X	
618-1			X	X	
623			X	X	
624A			X	X	
624B			X	X	
624C			X	X	
624D			X	X	
651			X	X	
652			X	X	
653 (03) (04)			X	X	
655			X	X	
659			X	X	
660			X	X	
661			X	X	
662			X	X	
663			X	X	
664(01)			X	X	
664(02)			X	X	
664A			X	X	
664B			X	X	
664C			X	X	
665			X	X	
706			X	X	
708			X	X	
808			X	X	

Parts number	New FE	Old FE	New FM	Old FM	Remarks
808A			X	X	
811-5		X	X	X	
816				X	
819-5		X	X	X	Change Product cord from P33FB-819
828			X	X	
834			X	X	
837				X	
839			X	X	
846			X	X	
854			X	X	
855				X	
856		X	X	X	Change Product cord from P33FB-856
858-5		X	X	X	Change Product cord from P33FB-858
861			X	X	
867			X	X	
869-2			X	X	
870			X	X	
873			X	X	
874			X	X	
877			X	X	
878A-5		X	X	X	Change Product cord from P33FB-878A
878B-5		X	X	X	Change Product cord from P33FB-878B
880			X	X	
884-5			X		
885				X	
886				X	

Parts number	New FE	Old FE	New FM	Old FM	Remarks
899			X	X	
904				X	
905				X	
G2K			X	X	
G2B			X	X	
A29			X	X	
A30			X	X	
B-2(01)				X	
B-2(02)				X	
B-6(01)			X		
B-6(02)			X		
B2				X	
B2-6			X		
B3-1(01)				X	
B3-1(02)				X	
B4(01)				X	
B4(02)				X	
B4-6(01)			X		
B4-6(02)			X		
B5-5		X	X	X	Change Product cord from P33FB-B5-1
B6-5		X	X	X	Change Product cord from P33FB-B6-1
B11				X	
B12				X	
B12-6			X		
B13-1				X	
B15-1				X	

Parts control cross reference list

33FB

Parts number	New FE	Old FE	New FM	Old FM	Remarks
B16					
B16-5			X	X	
B17-1					Change Part number to B17-5
B17-5			X	X	
B18-2				X	
B19			X	X	
B21				X	
B26				X	
B26-6			X	X	
B27-1				X	
B28-1				X	
B28-6			X		
B30-1(01)			X	X	
B30-1(02)			X	X	
B32				X	
B32-6			X		
B36-6			X		
B39-5			X		
B40-6			X		
C-1(01)				X	
C-1(02)				X	
C-6(01)			X		
C-6(02)			X		
C1-1			X	X	
C3-1				X	
F-2			X	X	

Parts number	New FE	Old FE	New FM	Old FM	Remarks
F2-1			X	X	
F7-1			X	X	
H1-1			X	X	
K				X	
K-6			X		
K4				X	
M			X	X	
N1			X	X	
N2			X	X	
N4			X	X	
N6-5			X		
P3-1(01)			X	X	
P3-1(02)			X	X	
P4				X	

Parts number	New FE	Old FE	New FM	Old FM	Remarks
67	X	X			
68(01)	X	X			
68(02)	X	X			
78	X	X			
79	X	X			
81	X	X			
84	X	X			
95	X	X			
100	X	X			Refer to Technical Info. FE-790008 #100 is a new shutter.
118A	X	X			
118B	X	X			
122	X	X			
126A		X			
126B		X			
127	X	X			
128A	X	X			
128B	X	X			
129	X	X			
130	X	X			
131	X	X			
132	X	X			
133	X	X			
134	X	X			
135		X			
135-6	X				
136		X			

Parts number	New FE	Old FE	New FM	Old FM	Remarks
137		X			
138	X	X			
139	X	X			
140	X	X			
142	X	X			
143	X	X			
144	X	X			
145	X	X			
146	X	X			
201		X			
214A-6	X				
222		X			
232	X	X			
233	X	X			
236	X	X			
240		X			
240-5	X	X			
250A		X			
250-1	X				
251(03)		X			
251(04)		X			
251-1	X				
252		X			
252-1	X				
253					Change Part number to 253-1
253-1	X	X			

Parts number	New FE	Old FE	New FM	Old FM	Remarks
260	X	X			
266		X			
267		X			
270					Change Product cord to P33FB-270-5
283-1					Change Product cord to P33FB-283-5
284-1		X			
313					Change Product cord to P33FB-313-5
314	X	X			
318					Change Product cord to P33FB-318-6
320		X			
321	X	X			
329		X			
338		X			
339-6	X				
343A	X	X			
343A-6	X	X			
348	X	X			
349		X			
361		X			
363		X			
370-5	X				
378					Change Product cord to P33FB-378-5
404A	X	X			
406-2	X	X			
468	X	X	X		Black finished for the new FM
469					Change Product cord to P33FB-469-6

Parts number	New FE	Old FE	New FM	Old FM	Remarks
470-5	X	X		X	Change Product cord from P33FB-470
476		X			
490		X			
490-1	X	X			
491	X	X			
493A	X	X			
493B	X	X			
493C	X	X			
503-1	X	X			
518A	X	X			
519	X	X			
527	X	X			
540B		X			
540C		X			
540D		X			
541A	X	X			
541D	X	X			
575(01)	X	X			
575(02)	X	X			
577	X	X			
631A	X	X			
639	X	X			
641	X	X			
642	X	X			
651		X			
651-1	X	X			

Parts number	New FE	Old FE	New FM	Old FM	Remarks
652-1	X	X			
653	X	X			
655	X	X			
659	X	X			
660	X	X			
662	X	X			
664-1	X	X			
665-1	X	X			
669	X	X			
670	X	X			
671	X	X			
672	X	X			
676	X	X			
686	X	X			
687	X	X			
688	X	X			
689	X	X			
691	X	X			
692	X	X			
693	X	X			
697	X	X			
698	X	X			
706	X	X			
708	X	X			
806-5	X	X		X	Change Product cord from P33FB-806
807-6	X				

Parts number	New FE	Old FE	New FM	Old FM	Remarks
818	X	X			
822	X	X			
826-1	X	X			
827					Change Product cord to 899
827-1	X	X			
828		X			
829	X	X			
834		X			
834-6	X				
836	X	X			
837		X			
839-1	X	X			
839A	X				
861	X	X			
862	X	X			
863					Change Product cord to P33FB-863-5
873	X	X			
877		X			
880	X	X			
884-5	X				
885-5	X				
886-5	X				
896	X	X			
898	X	X			
899	X	X			Change Product cord from 827
904		X			

Parts number	New FE	Old FE	New FM	Old FM	Remarks
905		X			
930		X			
930-6	X				
934	X	X			
935	X	X			
936	X	X			
937	X	X			
939		X			
943A	X	X			
943B	X	X			
943C	X	X			
943D	X	X			
944A	X	X			
944B	X	X			
945A	X	X			
945B	X	X			
945C	X	X			
946	X	X			
947-1		X			
948		X			
949-5	X				
951	X				
952-5	X				
RA	X	X			
RB	X	X			
RF	X	X			

Parts number	New FE	Old FE	New FM	Old FM	Remarks
G2K	X	X			
G9	X	X			
G10	X	X			
G2B(03)	X	X			
G2E(03)	X	X			
G2K(03)	X	X			
B-1(01)		X			
B-1(02)		X			
B-5(01)	X	X			
B-5(02)	X	X			
B2		X			
B2-6	X				
B4(01)		X			
B4(02)		X			
B4-6(01)	X				
B4-6(02)	X				
B6-6	X				
B7		X			
B7-6	X				
B9-1		X			
B9-6	X				
B11		X			
B12		X			
B12-6	X				
B13-1		X			
B15-6	X				

Parts number	New FE	Old FE	New FM	Old FM	Remarks
B16		X			
B17-1		X			
B19		X			
B19-6	X				
B22-1	X	X			
B25		X			
B25-6	X				
B26		X			
B26-6	X				
B27		X			
B30(01)		X			
B30(02)		X			
B30-6(01)	X				
B30-6(02)	X				
B32	X	X			
B34		X			
B35		X			
B35-6	X				
B36-6	X				
B37-1		X			
B38					Change Product cord to P33FB-B38-5
B39		X			
C(01)		X			
C(02)		X			
C-6(01)	X				
C-6(02)	X				

Parts number	New FE	Old FE	New FM	Old FM	Remarks
C1	X	X			
C5	X	X			
C6	X	X			
F(01)	X	X			
F(02)	X	X			
F1	X	X			
F2	X	X			
F3	X	X			
F4A(01)	X	X			
F4A(02)	X	X			
H1-1	X	X			
J	X	X			
K		X			
K-6	X				
K3		X			
K4		X			
M	X	X			
N1	X	X			
N4	X	X			
P3-1(01)	X	X			
P3-1(02)	X	X			
P4		X			
R	X	X			
R1	X	X			
R2	X	X			

Parts number	New FE	Old FE	New FM	Old FM	Remarks
4A	X	X	X	X	
10	X	X	X	X	
13	X	X	X	X	
15	X	X	X	X	
25-1		X		X	
25-2	X		X		
26-1		X		X	
26-2	X		X		
28-1		X		X	
28-2	X		X		
29		X		X	
29-1	X		X		
30-1(03)		X		X	
30-1(04)		X		X	
31-1(03)		X		X	
31-1(04)		X		X	
31-2	X		X		
45-1	X	X	X	X	
50	X	X	X	X	
51	X	X	X	X	
54(01)	X	X	X	X	
54(02)	X	X	X	X	
55	X	X	X	X	
58-1	X	X	X	X	
58A-1	X	X	X	X	
58B-1	X	X	X	X	

Parts number	New FE	Old FE	New FM	Old FM	Remarks
59	X	X	X	X	
60	X	X	X	X	
63	X	X	X	X	
64	X	X	X	X	
65(01)	X	X	X	X	
65(02)	X	X	X	X	
69	X	X	X	X	
70-1	X	X	X	X	
71-1	X	X	X	X	
73	X	X	X	X	
74	X	X	X	X	
80		X		X	
82-1	X	X	X	X	
85-1	X	X	X	X	
97	X		X		
98-1	X		X		
126-5	X		X		
202		X		X	
202-5	X	X	X	X	
208		X		X	
208-6	X		X		
210		X		X	
217-1					Change Product cord to 33FB-217-5
223		X		X	
261	X	X	X	X	
270-5	X	X	X		Change Product cord from 35FB-270

Parts number	New FE	Old FE	New FM	Old FM	Remarks
281-1	X	X	X	X	
283-5	X	X	X		Change Product cord from 35FB-283-1
284-6	X		X		
288-1	X	X	X	X	
289-1	X	X	X	X	
291					Change Product cord to 33FB-291-5
291A					Change Product cord to 33FB-291A-5
291B					Change Product cord to 33FB-291B-5
313-5	X	X	X		Change Product cord from 33FB-313
318-6	X	X	X		Change Product cord from 35FB-318
320A	X	X	X	X	
326A	X	X	X	X	
328	X	X	X	X	
330	X	X	X	X	
331					Change Product cord to 33FB-331-5
340	X	X	X	X	
341	X	X	X	X	
344					Change Part number to 344-5
344-5	X	X	X	X	
352-2	X	X	X	X	
355-2	X	X	X	X	
357					Change Product cord to 33FB-357-5
363-6	X		X		
372	X	X	X	X	
375					Change Part number to 375-5
375-5	X	X	X	X	

Parts number	New FE	Old FE	New FM	Old FM	Remarks
378-5	X	X	X		Change Product cord from 35FB-378
379-1		X		X	
379-6	X		X		
383		X		X	
383-1	X		X		
394	X	X	X	X	
395	X	X	X	X	
402	X	X	X	X	
403-1(01)	X	X	X	X	
403-1(02)	X	X	X	X	
405-2	X	X	X	X	
406					Change Product cord to 33FB-406-1
408	X	X	X	X	
408A	X	X	X	X	
412		X		X	
412-6	X		X		
413		X		X	
413-6	X		X		
414B-5	X		X		
415-6	X		X		
429	X	X	X	X	
431		X		X	
431-6	X		X		
432		X		X	
432-6	X		X		
433		X		X	

Parts number	New FE	Old FE	New FM	Old FM	Remarks
434		X		X	
434-6	X		X		
435	X	X	X	X	
435A	X	X	X	X	
436-1	X	X	X	X	
437	X	X	X	X	
438		X		X	
438-6	X		X		
439	X	X	X	X	
441		X		X	
441-6	X		X		
450	X	X	X	X	
460	X	X	X	X	
462	X	X	X	X	
464	X	X	X	X	
465	X	X	X	X	
467-1	X	X	X	X	
469-6	X	X	X		Change Product cord from 35FB-469
470					Change Product cord to 35FB-470-5
473		X		X	
483		X		X	
483-6	X		X		
487		X		X	
488		X		X	
489		X		X	
489A	X		X		

Parts number	New FE	Old FE	New FM	Old FM	Remarks
489-6	X		X		
495	X	X	X	X	
496		X		X	
496-6	X	X	X	X	
498	X	X	X	X	
499-1		X		X	
502-1	X	X	X	X	
505		X		X	
505-6	X		X		
506		X		X	
507		X		X	
508		X		X	
508-6	X		X		
509-6	X		X		
510-6	X		X		
511-6	X		X		
512		X		X	
514		X		X	
521		X		X	
521-6	X		X		
522-6	X		X		
522A-5	X		X		
523		X		X	
527A	X	X	X	X	
527B-1	X	X	X	X	
531-1		X		X	

Parts number	New FE	Old FE	New FM	Old FM	Remarks
531-6	X		X		
532-1		X		X	
532-6	X		X		
534		X		X	
533	X	X	X	X	
535A	X	X	X	X	
535B-1	X	X	X	X	
536	X	X	X	X	
537		X		X	
537-6	X		X		
537A		X		X	
537B		X		X	
538	X	X	X	X	
538A	X	X	X	X	
539	X	X	X	X	
540A		X		X	
656	X	X	X	X	
666-1	X	X	X	X	
709	X	X	X	X	
714	X	X	X	X	
722	X	X	X	X	
725	X	X	X	X	
726	X	X	X	X	
727	X	X	X	X	
728	X	X	X	X	
730	X	X	X	X	

Parts number	New FE	Old FE	New FM	Old FM	Remarks
731	X	X	X	X	
732	X	X	X	X	
801	X	X	X	X	
802	X	X	X	X	
803(01)	X	X	X	X	
803(02)	X	X	X	X	
804A(01)	X	X	X	X	
804A(02)	X	X	X	X	
804B	X	X	X	X	
805	X	X	X	X	
806					Change Product cord to 35FB-806-5
810	X	X	X	X	
811		X		X	
812					Change Part number to 812-5
812-5	X	X	X	X	
812A-5	X		X		
813(01)	X	X	X	X	
813(02)	X	X	X	X	
815					Change Part number to 815-5
815	X	X	X	X	
815A-5	X		X		
817	X	X	X	X	
819					Change Product cord to 33FB-819-5
820	X	X	X	X	
821	X	X	X	X	
823A	X	X	X	X	

Parts number	New FE	Old FE	New FM	Old FM	Remarks
823B	X	X	X	X	
823C	X	X	X	X	
823D	X	X	X	X	
824	X	X	X	X	
825A	X	X	X	X	
825					Change Part number to 825-5
825-5	X	X	X	X	
830	X	X	X	X	
831		X		X	
831-6	X		X		
832	X	X	X	X	
833-1	X	X	X	X	
835	X	X	X	X	
840	X	X	X	X	
841	X	X	X	X	
842A	X	X	X	X	
842B	X	X	X	X	
842C	X	X	X	X	
842D	X	X	X	X	
842E	X	X	X	X	
842F	X	X	X	X	
842G	X	X	X	X	
842H	X	X	X	X	
842I	X	X	X	X	
842J	X	X	X	X	
842K					Change Part number to 842K-5

Parts number	New FE	Old FE	New FM	Old FM	Remarks
842K-5	X	X	X	X	
842M	X	X	X	X	
842N	X	X	X	X	
842P	X	X	X	X	
842Q	X	X	X	X	
842R	X	X	X	X	
842S	X	X	X	X	
842T	X	X	X	X	
842U	X	X	X	X	
842V	X	X	X	X	
843					Change Part number to 843-5
843-5	X	X	X	X	
844-5	X		X		
845					Change Part number to 845-5
845-5	X	X	X	X	
845A-5	X		X		
848		X		X	
848-1	X	X	X	X	
850-1	X	X	X	X	
855A	X	X	X	X	
856					Change Product cord to 33FB-856
857					Change Part number to 857-5
857-5	X	X	X	X	
858					Change Product cord to 33FB-858-5
863-5	X	X	X		Change Product cord from 35FB-863
871	X	X	X	X	

Parts number	New FE	Old FE	New FM	Old FM	Remarks
875	X	X	X	X	
878A					Change Product cord to 33FB-878A-5
878B					Change Product cord to 33FB-878B-5
879	X	X	X	X	
882	X	X	X	X	
883	X	X	X	X	
887	X	X	X	X	
888	X	X	X	X	
889	X	X	X	X	
890-1	X	X	X	X	
893		X		X	
897A	X	X	X	X	
897B	X	X	X	X	
897C	X	X	X	X	
897D	X	X	X	X	
897E	X	X	X	X	
897F	X	X	X	X	
910	X	X	X	X	
911	X	X	X	X	
912	X	X	X	X	
913	X	X	X	X	
914	X	X	X	X	
915	X		X		
923	X	X	X	X	
950	X		X		
G1	X	X	X	X	

Parts number	New FE	Old FE	New FM	Old FM	Remarks
G3	X	X	X	X	
G6	X	X	X	X	
A2		X		X	
A2-1	X	X	X	X	
A4		X		X	
A4A(03)		X		X	
A4A(04)		X		X	
A4-1	X		X		
A5-2	X	X	X	X	
A6(03)		X		X	
A6(04)		X		X	
A6-5	X	X	X	X	
A7-1	X	X	X	X	
A8	X	X	X	X	
A9	X	X	X	X	
A10A-1		X		X	
A10B-2	X	X	X	X	
A11		X		X	
A11-6	X		X		
A12		X		X	
A12-6	X	X	X	X	
A13-6	X		X		
A14	X	X	X	X	
A17-1	X	X	X	X	
A18		X		X	
B1(01)	X	X	X	X	

Parts number	New FE	Old FE	New FM	Old FM	Remarks
B1(02)	X	X	X	X	
B5-1					Change Product cord to 33FB·B5-5
B6-1					Change Product cord to 33FB·B6-5
B10	X	X	X	X	
B11-6	X		X		
B13-6	X		X		
B14	X	X	X	X	
B20		X		X	
B20-1	X		X		
B27-6	X		X		
B33-2	X	X	X	X	
B38-5	X	X	X		Change Product cord from 35FB·B38
C4	X	X	X	X	
C7	X	X	X	X	
D-1(01)	X	X	X	X	
D-1(02)	X	X	X	X	
E1	X	X	X	X	
E2	X	X	X	X	
K5		X		X	
K6		X		X	
P5	X	X	X	X	

部品表 Parts List

33FB-R-3001-A

部品番号 Part No.	名 称 Name	1 台 個 数 Pcs. per Unit	部組品No. Sub- assembly No.	参照図番 Reference Fig. No.	販売区 分 Term of Sale	備 考 Remarks
1	ボディ Body	1			X	
1-5	ボディ Body	1			X	
2-1 (01) (02)	前カバー 銘板 Front cover (Name plate)	1	B30-1 B-2 B-6		Δ	
3-1 (01) (02)	上カバー Top cover	1	C-1		Δ	
3-6 (01) (02)	上カバー Top cover	1	C-6		Δ	
6	前 板 Front plate	1	B-2		Δ	
6-6	前 板 Front plate	1	B-6		Δ	
7-1 (01) (02)	接眼窓受 Eyepiece mount	1	C-1 C-6		Δ	
17	セルフレバー軸 Self-timer lever axle	1	B2 B-2		Δ	
17-6	セルフレバー軸 Self-timer lever axle	1	B2-6 B-6		Δ	
18	セルフ連動レバー Self-timer lever	1	B2-6 B-6		Δ	
21	チャージレバー Charge lever	1	A6-5		Δ	
23	チャージレバーローラー Charge lever roller	1	A6-5		Δ	
39	前板右肩カバー Shoulder cover, right	1		8 8-1	○	

部 品 表 Parts List

33FB-R-3001-A

部品番号 Part No.	名 称 Name	1 台 調 数 Pcs. per Unit	部組品No. Sub- assembly No.	参照図番 Reference Fig. No.	販 売 区 分 Term of Sale	備 考 Remarks
40	前板左肩カバー Shoulder cover, left	1		8 8-1	○	
52	コード溝カバー Lead wire cover	1		12 12-1	○	
53	前板孔カバー Front plate hold cover	1		8	○	
56	ボディ擬革A Body leatherette A	1		15-1	○	
57	ボディ擬革B Body leatherette B	1		15-1	○	
61	ミラーアップ受けモルト Mirror-up cushion sponge	1	B-2 B-6 B39-5	8 8-1	○△	32FB1 #345
66-1	シュー座モールド Hot-shoe mould	1	C-1 C1-1 C-6		△	
67-1	ホットシュー Hot-shoe contact	1	C-1 C-6	1 1-1	○△	
68 (01) (02)	シューばね Shoe contact	1	C-1 C-6	1 1-1	○△	S-6021A
76	シンクロ接点ナット Sync. socket nut	1	C-1 C-6	1 1-1	○△	
78	ペンタ革 Penta-prism cover leatherette	1	C-1 C-6	1 1-1	○△	
79-1	緩衝板 Baffle plate	1		4-1 13	○	
80	前板孔カバーB Front plate hole cover B	1		8	○	
80-6	前板孔カバー Front plate hole cover	1		8-1	○	

部品表 Parts List

33FB-R-3001-A

部品番号 Part No.	名 称 Name	1 台 個 数 Pcs. per Unit	部組品No. Sub- assembly No.	参照図番 Reference Fig. No.	販 売 区 分 Term of Sale	備 考 Remarks
81	FRE シート絶縁 FRE insulator	1	C-1 C-6	1 1-1	○△	
83	ミラーボックス後部モルト Mirror box rear light-tight	1	B-2	8	○△	
87	コード押えテープ Retaining tape	3		8 8-1	○	
90	MDスイッチ絶縁テープ MD Switch insulator tape	1	C-1	1	○△	
100	シャッター Shutter	1	A30		△	
101	測光用 IC プリント板 IC printed circuit	1	M		△	
102	IC IC	1	M		△	
103	バイパスコンデンサー Bypass capacitor	1	M		△	6V DC 6.7 μ F
104	FRE γ 用抵抗 FRE γ resistor	1	M		△	0.125W 4.7K Ω
106	FRE 調整抵抗 FRE variable resistor	2	M		△	5K Ω B
107	ラッチ防止抵抗-A Latch cutoff resistor A	1	M		△	1/8W 33K Ω
108	ラッチ防止ダイオード Latch cutoff diode	1	M		△	
109	ラッチ防止コンデンサA Latch cutoff capacitor A	1	M		△	10V 4.7 μ F
112	フィルター用コンデンサー Filter capacitor	1	M		△	3.15V 10 μ F

部 品 表 Parts List

33FB-R-3001-A

部品番号 Part No.	名 称 Name	1 台 個 数 Pcs. per Unit	部組品No. Sub- assembly No.	参照図番 Reference Fig. No.	販 売 区 分 Term of Sale	備 考 Remarks
114	オフセット調整抵抗 Offset adjust resistor	1	M		△	10KΩB
117	発光ダイオード Light-emitting diode	1	M		△	
118	ラッチ防止抵抗-B Latch cutoff resistor B	1	M		△	1/4W 4.7MΩ
119	IC アースピン IC grounder pin	1	M		△	
120	IC ピン絶縁チューブ IC pin insulator tube	1	M		△	
151	レバースイッチリード線B Lead wire, lever SW B	1		3	○	(Red x 170)
152	FRE リード線A Lead wire, FRE, A	1	M		○△	(Pink x 70)
155	PD テフロン線A Lead wire, PD, A	1	M	8 8-1	○△	(Red x 28)
155A	PD リード線A Lead wire, PD, A	1	M	8 8-1	○△	(White x 28)
156	PD テフロン線C Lead wire, PD, C	1	M	8 8-1	△	(Red x 32)
156A	PD リード線B Lead wire, PD, B	1	M	8 8-1	△	(White x 35)
160	MD測光用電源リード線A Lead wire, power source A	1		13 13-1	○	(Yellow x 110)
161	MD測光用電源リード線B Lead wire, power source B	1		12 12-1	○	(Red x 40)
162	MDスイッチリード線 Lead wire, MD switch	1	K	2 13-1	○△	(Blue x 180)

部 品 表 Parts List

33FB-R-3001-A

部品番号 Part No.	名 称 Name	1 台 個 数 Pcs. per Unit	部組品No. Sub- assembly No.	参照図番 Reference Fig. No.	販 売 区 分 Term of Sale	備 考 Remarks
163	後幕シグナルリード線A Lead wire, rear curtain signal A	1		13 13-1 12 12-1	○	(Green x 45)
164	後幕シグナルリード線B Lead wire, rear curtain signal B	1	K	2 12	○△	(Purple x 205)
175	シンクロリード線 Lead wire, sync.	1		6-1	○	(Green x 145)
176	レバースイッチリード線A Lead wire, lever switch	1		3	○	(Orange x 170)
177	電源マイナスリード線 Lead wire, grounder	1			○	(Black x 85)
178	測光用電源リード線 Lead wire, power source	1		12-1	○	(Red x 80)
201	マウント台 Lens mount base	1	B-2 B3-1	7	○△	
201-6	マウント台 Lens mount base	1	B-6	7-1	○△	
207 (01)(02)	絞り連動環 Aperture coupling ring	1	B-1 B3-1		△	
207-6 (01)(02)	絞り連動環 Aperture coupling ring	1	B-6 B4-6		△	
210A-5	引張ばねかけピン Spring pin	1	B4-6 B-6	7-1	○△	
212-5	着脱ピン Lens release pin	1	B-2 B-6 B5-5 B5-1		△	32FB1 #212
213-5	着脱レバー Lens release lever	1	B-2 B-6 B5-5 B5-1		△	
214-5	着脱レバー受け Lens release lever coupling	1	B-2 B-6 B6-1 B6-5		△	

部品表 Parts List

33FB-R-3001-A

部品番号 Part No.	名 称 Name	1 台 備 数 Pes. per Unit	部組品No. Sub- assembly No.	参照図番 Reference Fig. No.	販 売 区 分 Term of Sale	備 考 Remarks
214A-5	着脱レバー押えばね Lens release lever spring	1	B-2 B-6 B6-1 B6-5		△	
215-5	着脱ボタン軸 Lens release button shaft	1	B-2 B-6 B6-1 B6-5		△	
217-5	着脱ボタン Lens release button	1	B-2 B-6 B6-1 B6-5	10 10-1	○△	
221-1	引張ばね (d = 0.23) Spring	1	B-2 B-6 B3-1	7 7-1	○△	
222-1	連動環回転制限 Coupling ring stopper	1	B-2 B3-1	7	○△	
222-6	連動環回転制限 Coupling ring stopper	1	B-6	7-1	○△	
231	ペンタ押え板 Penta-prism retainer	1	N2		△	
232	プリズム押えシート Prism retainer	1		8 8-1	○	
233	プリズム押えばね Prism retainer spring (d=0.35)	2		8 8-1	○	32FB1 #264
235	ミラー保持基板 Mirror retaining base plate	1	N1		△	
236	ミラー調整板 Mirror adjusting plate	1	N1		△	
237	枠 板 F-mask plate	1		8 8-1	○	
239	ペンタ押えモルト Prism retaining sponge	1	N2		△	
241	プリント板保持板 Printed circuit holder	1	M		△	

部品表 Parts List

33FB-R.3001-A

部品番号 Part No.	名 称 Name	1 台 個 数 Pcs. per Unit	部組品No. Sub- assembly No.	参照図番 Reference Fig. No.	販 売 区 分 Term of Sale	備 考 Remarks
241A	保持板ハトメ Holder eyelet	2	M		△	
242	記号表示フィルム Exposure mark film	1	M		△	
250	プリズムボックス Prism box	1	B-2	8	○△	
250-6	プリズムボックス Prism box	1	B-6 B40-6		△	
251	視野枠 Viewfield mask	1		8	○	
251-6	視野枠 Viewfield mask	1	B-6 B40-6		△	
252	間隔枠 Spacer	1		8	○	
252-6	間隔枠 Spacer	1		8-1	○	
253	プリズム絞り板 Prism mask	1		8 8-1	○	
254-1	接眼横遮光板A Light baffle A	1	N4		△	
256-1	接眼横遮光板B Light baffle B	1	N4		△	
258	フォトダイオード Photo diode	2	M		△	
259	接眼モールド Eyepiece mold	1	N4		△	
260-1	メガネ絞り板 Eyepiece diaphragm blade	1	N4		△	

部 品 表 Parts List

33FB-R-3001-A

部品番号 Part No.	名 称 Name	1 台 個 数 Pcs. per Unit	部組品No. Sub- assembly No.	参照図番 Reference Fig. No.	販 売 区 分 Term of Sale	備 考 Remarks
262-5	フレネル板枠 Focusing screen frame	1		8-1	○	
263-5	フレネルばね受け枠 Focusing screen frame	1	N6-5		△	
264-5	フレネルばね Focusing screen spring	1		8-1	○	
265-5	受 板 Focusing screen support	1	B-6 B39-5		△	
266-5	フレネルばね受けモルトA Focusing screen frame sponge A	1	N6-5	8-1	○△	
267-5	フレネルばね受けモルトB Focusing screen frame sponge B	1	N6-5	8-1	○△	
268-5	フレネルばね受け枠モルトC Focusing screen frame sponge C	1	N6-5	8-1	○△	
282	ブレーキ解除軸 Brake release shaft	1	B-2	11	○△	
283-1	ブレーキ解除軸カラー Collar	1	B-2	11	○△	
284	中間レバー座金 Brake middle-lever base	1	B-2	11	○△	
291-5	係止レバー軸 Latch lever axle	1	B-2 B-6	9 9-1	○△	
291A-5	係止レバー調整座金(3×5×0.05) Washer	1	B-6	9-1	○△	
291B-5	係止レバー調整座金(3×5×0.08) Washer	1	B-6	9-1	○△	
302	巻上機チリトリ回転軸 Mirror shaft	1	B-6 B-2	9 9-1	○△	

部品表 Parts List

33FB-R-3001-A

部品番号 Part No.	名 称 Name	1 台 個 数 Pcs. per Unit	部組品No. Sub- assembly No.	参照図番 Reference Fig. No.	販 売 区 分 Term of Sale	備 考 Remarks
303	巻上側チリトリ回転軸 Mirror shaft	1	B-2 B-6	10 10-1	○△	
304	ミラーチリトリ駆動板 Mirror holder actuating plate	1	B-2 B-6 B26 B26-6		△	
305	エアダンパー駆動板 Air damper actuating plate	1	B-2 B-6 B26 B26-6		△	
308	チリトリピンB Mirror holder pin	1	B-2 B-6 B26 B26-6		△	
309	絞り込みレバー Diaphragm set lever	1	B-2 B32		△	
309-6	絞り込みレバー Diaphragm set lever	1	B-6 B32-6		△	
311-1	手動絞りレバー軸(A) Manual stop-down lever shaft (A)	1	B-2 B27-1		△	
311A	手動絞りレバー軸(B) Manual stop-down lever shaft (B)	1	B-2 B32		△	
311A-6	インサート板 Insert plate	1	B-6 B32-6		△	
313	手動絞りレバーばね Manual stop-down lever spring	1	B-2	9	○△	
314	絞りレバービス Stop-down lever screw	1	B-2	9	○△	
314-6	絞りレバービス Stop-down lever screw	1	B-6	9-1	○△	
317-5	45° ストッパー 45° stopper	1	B-2 B-6 B16 B16-5		△	
320	シャッターリリースレバーカラー Collar	1	B-2 B-6	9 9-1	○△	

部 品 表 Parts List

33FB-R-3001-A

部品番号 Part No.	名 称 Name	1 台 個数 Pcs. per Unit	部組品No. Sub- assembly No.	参照図番 Reference Fig. No.	販売 区分 Term of Sale	備 考 Remarks
321A	シャッターレリーズレバー Shutter release lever	1	B-2 B-6	9 9-1	○△	
321B	シャッターレリーズレバー Shutter release lever	1	B-2 B-6	9 9-1	○△	
321C	シャッターレリーズレバー Shutter release lever	1	B-2 B-6	9 9-1	○△	
322	ミラーアップレバー Mirror-up lever	1	B-2 B12 B15		△	
322-6	ミラーアップレバー Mirror-up lever	1	B-6 B12-6		△	
323	ミラーダウンレバー Mirror-down lever	1	B-2 B13-1 B15		△	
326-5	ミラーレバー軸 Mirror lever axle	1	B2,B-6 B15 B17 B17-5		△	
329	ミラーアップ押えレバー Mirror-up lever	1	B-2 B-6	9 9-1	○△	
331-5	ミラーアップ押えレバー軸 Mirror-up lever axle	1	B-2 B-6	9 9-1	○△	
334	大レバー軸 Mirror change lever axle	1	B-2	11	○△	
335	大レバー軸ブッシュ Mirror change lever axle bush	1	B-1 B11		△	
336	底遮光板 Bottom light baffle	1	B-2	8	○△	
337	45° ストッパー座 45° stopper base	1	B-2 B-6 B16 B16-5		△	
339-5	45° ストッパーばね 45° stopper spring (d=0.32)	1	B-2 B-6 B16 B16-5	8 8-1	○△	

部品表 Parts List

33FB-R.3001-A

部品番号 Part No.	名 称 Name	1 台 個数 Pcs. per Unit	部組品No. Sub- assembly No.	参照図番 Reference Fig. No.	販売 区分 Term of Sale	備 考 Remarks
342-1	保持レバー制限 Link lever stopper	1	B-2	11	○△	
343-1	ダウンばね Mirror-down spring (d=0.8)	1	B-2	11	○△	
343-6	ダウンばね Mirror-down spring (d=0.8)	1	B-6 B36-6	11-1	○△	
348	シャッターリリースばね Shutter release spring (d=0.26)	1	B-6	9-1	○△	
349	ミラーアップ押えばね Mirror-up spring (d=0.26)	1	B-6 B-2	9 9-1	○△	
350	ミラーアップレバー係止ピン Mirror-up lever latch pin	1	B-2 B13-1 B15		△	
353	MD巻上げ中間レバー軸 MD take-up signal middle lever axle	1	B-2 B18-2		△	
354	中間レバー基板 Middle lever base plate	1	B-2 B18-2		△	
355A	保持レバーばね軸 Lever spring axle	1	B-2	11	○△	
357-5	シグナルレバー止めビス Signal lever screw	1	B-2 B-6	9 9-1	○△	
361	ミラーアップ押えレバーばね掛け Signal stud	1	B-2 B-6	9 9-1	○△	
362	ダウンレバー調整レバー Down lever adjusting lever	1	B21 B-2		△	
363	ダウンレバー緩衝ゴム Shock absorb rubber	1	B21 B-2		△	
364	緩衝ゴム固定ピン Cushion rubber holder pin	1	B-2 B21		△	

部品表 Parts List

33FB-R-3001-A

部品番号 Part No.	名 称 Name	1 台 個数 Pcs. per Unit	部組品No. Sub- assembly No.	参照図番 Reference Fig. No.	販売 区分 Term of Sale	備 考 Remarks
367	調整レバー偏心軸 Down lever eccentric	1	B-2	11	○△	
368	ダウンレバー調整レバー軸 Down lever adjust axle	1	B-2	11	○△	
374	ミラー巻戻側カラー Collar	1	B-2	10	○△	
374-6A	ミラー巻戻側ワッシャー (0.9×1.9×0.5) Washer	1	B-6	10-1	○△	
374-6B	ミラー巻戻側ワッシャー (0.9×1.9×0.6) Washer	1	B-6	10-1	○△	
377	ミラーレバー軸取付板 Mirror lever shaft base	1	B2,B-6 B15 B17 B17.5		△	
382	ミラー Springs (大) 掛ピン Mirror latch spring	1	B-2 B12 B15		△	
401A-1	巻上レバーブッシュ Film-advance lever bush	1	B3-1		△	
404 (01) (02)	巻上げ部飾り環 Film-advance lever ring	1	C-1 C-6		△	
404A	枚数計押え板 Counter retaining plate	1	K K-6	2 2-1	○△	
406-1	レバー戻しばね Film-advance lever retaining spring	1		1 1-1	○	
451	上地板 Upper base plate	1	K		△	
468-1 (01) (02)	リリース釦飾り環 Release button ring	1	C-1	1	○△	
468-6	リリース釦飾り環 Release button ring	1	C-6	1-1	○△	

部品表 Parts List

33FB-R-3001-A

部品番号 Part No.	名 称 Name	1 台 個 数 Pcs. per Unit	部組品No. Sub- assembly No.	参照図番 Reference Fig. No.	販 売 区 分 Term of Sale	備 考 Remarks
469-1	かぶせリリース環 Release ring	1	C-1 C3-1		Δ	
470	リリース内筒 Release inner tube	1	C-1	1	○Δ	
470-6	リリース内筒 Release inner tube	1	C-6	1-1	○Δ	
471-1	回転ピン Stopper	1	C-1 C3-1		Δ	
472	スイッチ制限 Switch stopper	1	P4		Δ	
474-1	スイッチ絶縁カシメピン Switch insulator caulking pin	1	P4		Δ	
476	スイッチ制限ばね (d = 0.26) Switch stopper spring	1		2	○	
478-1	クリックレバー Click lever	1	C-1	1	○Δ	
484	スイッチレバー Lever switch	1	K4 K		Δ	
486-1	スイッチ絶縁体 Switch insulator	1	K4 K		Δ	
490	多重撮りアーム Multi-exposure arm	1		12	○	
490-5	多重撮りアーム Multi-exposure arm	1		12-1	○	
490A	多重ツマミ保護シート Multi-exposure knob washer	1 ~ 3	C-1 C-6	1 1-1	○Δ	
491 (01) (02)	多重撮りツマミ Multi-exposure knob	1	C-1 C-6	1 1-1	○Δ	

部 品 表 Parts List

33FB-R.3001-A

部品番号 Part No.	名 称 Name	1 台 個 数 Pcs. per Unit	部組品No. Sub- assembly No.	参照図番 Reference Fig. No.	販 売 区 分 Term of Sale	備 考 Remarks
492	多重振りアーム戻しばね (d = 0.3) Spring	1		12	○	
492-6	多重振りアーム戻しばね (d = 0.3) Spring	1		12-1	○	
493B	多重ツマミ 遮光板 Multi-exposure knob light baffle	1	C-6	1-1	○△	
494	ガイドピン Guide pin	1		12 12-1	○	
494A	多重アーム戻しばね掛け Spring stud	1		2	○	
503	枚数計窓 Counter window	1	C-6	1-1	○△	
518	リリースレバー Release lever	1	B-2 B-6 B19		△	
518A	リリースレバー 二股 Release lever fork	1	B-2 B-6	9 9-1	○△	
519	リリースレバー軸 Release lever axle	2	B-2 B-6	9 9-1	○△	
519A	リリースレバー 偏心ピン Eccentric pin	1	B-2 B-6 B19		△	
527-2	リリース軸 Release shaft	1		12 12-1	○	
535C-1	リリースボタンナット Release button nut	1	C-1	1	○△	
535D	リリースボタンナット Release button nut	1	C-1	1	○△	
540B	MDスイッチ座板 MD switch base plate	1	K	2	○△	

部品表 Parts List

33FB-R-3001-A

部品番号 Part No.	名 称 Name	1 台 個 数 Pes. per Unit	部組品No. Sub- assembly No.	参照図番 Reference Fig. No.	販 売 区 分 Term of Sale	備 考 Remarks
541-2	シャッター目盛基板 T-dial base plate	1	F-2	5-1	○△	
541A	シャッター目盛板 T-dial	1	F-2	5-1	○△	
542-2	ASA目盛板 ASA dial	1	F-2	5-1	○△	
543-3	ダイヤル外環 Dial knob	1	F-2	5-1	○△	
544-1	シャッター目盛座金 T-dial holder	1	F-2		△	
545-1	クラッチ Clutch	1	F-2		△	
546-1	ダイヤル内環 Dial knob	1	F-2		△	
547-1	ダイヤル軸受 Dial bearing	1	F-2		△	
548-1	ダイヤル軸 Dial shaft	1	F-2		△	
548A-1	ダイヤル軸制限環 Dial shaft stopper ring	1	F-2		△	
549	Tダイヤル基板 T-dial base plate	1	F-2		△	
550-2	FRE 軸 FRE shaft	1	F-2		△	
551	クラッチ座板 Clutch holder	1	F-2		△	
555	FRE プリント板紙 Pin	2	F-2		△	

部 品 表 Parts List

33FB-R-3001-A

部品番号 Part No.	名 称 Name	1 台 個数 Pcs. per Unit	部組品No. Sub- assembly No.	参照図番 Reference Fig. No.	販売区 区分 Term of Sale	備 考 Remarks
557-1	ダイヤル押ばね (d=0.7) Dial knob spring	1	F-2		△	
558	FRE 絶縁シート FRE insulator	1	F-2		△	
559-1	アース接片 Earth plate	1	F-2		△	
560	ブラシA Brush A	1	F-2		△	
561	ブラシ板 Brush mount	1	F-2		△	
564-2	ブラシ基板 Brush base plate	1	F-2		△	
566-1	ゼンマイ Spring	1	F-2		△	
567-1	FRE 下ブラシ Brush	1	F-2		△	
569-1	波形座金 Washer	1	F-2		△	
571	クリックプーリー Click pulley	1	A29	12 12-1	○△	
572	FRE プリントシート FRE printed seat	1	F-2		△	
574	FRE 押えばね FRE spring holder	1	F-2		△	
575-2 (01) (02)	飾り環 Cover ring	1	C-1 C-6	1 1-1	○△	
576	シャッター変速糸 T-dial string	1	A29	12 12-1	○△	

部 品 表 Parts List

33FB-R-3001-A

部品番号 Part No.	名 称 Name	1 台 個 数 Pcs. per Unit	部組品No. Sub- assembly No.	参照図番 Reference Fig. No.	販 売 区 分 Term of Sale	備 考 Remarks
577-2	飾り環座金 Washer	1	C-1 C-6	1 1-1	○△	
578-1	ダイヤル上面ビス Dial top screw	1	F-2	5-1	○△	
579	プーリー段ビス Shoulder screw	1	A30	12 12-1	○△	
581	アースばね (d=0.3) Spring	1		5-1	○	
582-1	Tダイヤルプーリー T-dial pulley	1	F7-1		△	
583-1	アイドルギヤ基板 Idle gear plate	1	B-2 B28-1		△	
583-6	アイドルギヤ基板 Idle gear plate	1	B-6 B28-6		△	
585	アイドルギヤA Idle gear A	1	B-2 B-6 B28-1 B28-6		△	
586	アイドルギヤB Idle gear B	1	B-2 B-6 B28-1 B28-6		△	
588	軸付ギア Gear	1	B-2	9	○△	
588-6	軸付ギア Gear	1	B-6	8-1	○△	
589	ギヤ軸受 Gear bearing	1	B-2	9	○△	
589-6	軸受板 Bearing plate	1	B-6	8-1	○△	
590	前小ギア Front pinion	1	B-2	8	○△	

部品番号 Part No.	名 称 Name	1 台 個 数 Pcs. per Unit	部組品No. Sub- assembly No.	参照図番 Reference Fig. No.	販 売 区 分 Term of Sale	備 考 Remarks
590-6	前小ギア Front pinion	1	B-6	8-1	○△	
591-1	アイドル軸A Idle shaft A	2	B-2 B-6 B28-1 B28-6		△	
594	S ロールピン Spring pin	1	B-2	9	○△	32FB1 #888
596	FRE 制限板 FRE stopper	1		5-1	○	
599	Tフィルム糸 T-film string	1	F7-1		△	
600	基板取付ビスB Control unit base screw	1		5-1	○	
614A-1	FRE 連動環 FRE coupling ring	1	F-2		△	
615-1	Tフィルム基板 T-film plate	1	F7-1		△	
616-1	Tフィルム軸 T-film shaft	1	F7-1		△	
617	Tフィルム糸巻き T-film spool	1	F7-1		△	
618-1	Tフィルムナット T-film nut	1	F7-1	8 8-1	○△	
619	Tフィルム座金 Washer	1	F7-1		△	
620	Tフィルム連結板 T-film connector	1	F7-1		△	
621	Tフィルム T-film	1	F7-1		△	

部品表 Parts List

33FB-R-3001-A

部品番号 Part No.	名 称 Name	1 台 個 数 Pcs. per Unit	部組品No. Sub- assembly No.	参照図番 Reference Fig. No.	販売 区 分 Term of Sale	備 考 Remarks
622	Tフィルムボス T-film boss	1	F7-1		△	
622A	Tフィルム保護板 T-film protector	1	F7-1		△	
623	Tフィルムばね (d=0.2) Spring	1	F7-1	8 8-1	○△	
624A	Tフィルム基板座金 (2.2×3.5×0.1) Washer	1		8 8-1	○	
624B	Tフィルム基板座金 (2.2×3.5×0.2) Washer	1		8 8-1	○	
624C	Tフィルム基板座金 (2.2×3.5×0.3) Washer	1		8 8-1	○	
624D	Tフィルム基板座金 (2.2×3.5×0.4) Washer	1		8 8-1	○	
651	巻戻軸受 Rewind shaft bearing	1		6-1	○	
652 (03)(04)	巻戻軸 Rewind shaft	1		6-1	○	
653	巻戻しノブ Rewind knob	1		6-1	○	
655	開閉ノブばね Spring	1		6-1	○	
657	巻戻ツマミ Rewind crank knob	1	H1-1		△	
658	巻戻ツマミ軸 Rewind crank knob shaft	1	A1-1		△	
659	開閉ノブ押えクリップ Knob clip	1		6-1	○	

部品表 Parts List

33FB-R-3001-A

部品番号 Part No.	名 称 Name	1台 個数 Pcs. per Unit	部組品No. Sub- assembly No.	参照図番 Reference Fig. No.	販売区 分 Term of Sale	備 考 Remarks
660	巻戻軸座金 Washer	1		6-1	○	
661	巻戻飾り板 Cover ring	1		6-1	○	
662	フリクションばね (d=0.4) Friction spring	1		6-1	○	
663	開閉ロックばね (d=0.5) Spring	1		6-1	○	
664 (01)(02)	開閉ノブ Back cover lock knob	1		6-1	○	
664A	巻戻円座スペーサー A (19.5×23×0.3) Rewind ring spacer A	1		6-1	○	
664B	巻戻円座スペーサー B (19.5×23×0.2) Rewind ring spacer B	1		6-1	○	
664C	巻戻円座スペーサー C (19.5×23×0.1) Rewind ring spacer C	1		6-1	○	
665	巻戻軸ガイド Rewind shaft guide	1		6-1	○	
706	裏蓋蝶番 A Back cover hinge A	1		15-1	○	
708	止め爪 B Latch B	1		15-1	○	
808	アイドルギア取付ビス Screw	1	B-2 B-6	9 9-1	○△	
808A	小ねじ ⊕ PM1.7×3.5 Screw	1	B-2 B-6	9 9-1	○△	
811-5	パヨネット台ビス Screw	4	B-6 B-2	7 7-1	○△	32FB#811

部品表 Parts List

33FB-R-3001-A

部品番号 Part No.	名 称 Name	1 台 個 数 Pcs. per Unit	部組品No. Sub- assembly No.	参照図番 Reference Fig. No.	販 光 区 分 Term of Sale	備 考 Remarks
816	小ねじ JCIS ⊕ PM 2 x 2 Type (3) Screw	1	B-2	9	○△	
819-5	小ねじ JCIS ⊕ PM 1.4 x 3 Type (3) Screw	2	B-2 B-6 B3-1 A11	7 7-1	○△	
828	小ねじ JCIS ⊕ CM 2 x 3.5 Type (1) Screw	2	B-2 B-6	8 8-1	○△	32FB #828
834	チリトリピン押えビス Screw	2	B-2 B-6	9,10 9-1 10-1	○△	
837	ダイヤルプーリー取付ビス Screw	1	K	2	○△	
839	小ねじ JCIS ⊕ PM 1.7 x 4 Type (3) Screw	1		8 8-1	○	32FB #839
846	調整板取付ビス Screw	2	N1	8 8-1	○△	
852-1	ブラシ取付ビス (タップタイト) ⊕ PM 1.4 x 2 Type (3) Screw	1	F-2		△	
854	ミラーアップ押えレバー座金 Washer (2.1 x 5 x 0.6)	1	B-2 B-6	9 9-1	○△	
855	小ねじ JCIS ⊕ PM 2 x 3.5 Type (3) Screw	1	B-2	11	○△	
856	多重ツマミ用Eリング E-ring (E-10)	1	C-1 C-6	1 1-1	○△	
858-5	ミラーボックス座金 (2.2 x 5 x 0.2) Washer	1	B-6 B-2	9 9-1	○△	32FB #858
861	シャッタークリックボール Click ball	1	A30	12 12-1	○△	
867	Sソケット止めじ SC 1.7 x 2 Set Screw	1		6-1	○	

部品番号 Part No.	名 称 Name	1 台 個 数 Pcs. per Unit	部組品No. Sub- assembly No.	参照図番 Reference Fig. No.	販 売 区 分 Term of Sale	備 考 Remarks
869-2	タッピンねじ JCIS ⊕ PM 1.4 x 2.8 Type (1) Screw	3	F-2	5-1	○△	
870	ダイヤル部セットビス SC 1.4 x 2.5 Set Screw	2	F-2	5-1	○△	
873	シュービス (短) JCIS ⊕ PM 1.7 x 5 Type (3) Screw	2	C-1 C-6	1 1-1	○△	
874	シュービス (長) JCIS ⊕ PM 1.7 x 8.2 Type (3) Screw	2	C-1 C-6	1 1-1	○△	
877	シャッターレリーズレバー軸 Release lever axle	1	B-2 B-6	9 9-1	○△	
878A-5	ダウン係止レバーストッパー Down-stopper lever stopper	1	B-2 B-6	9 9-1	○△	
878B-5	ダウン係止レバーストッパー Down-stopper lever stopper	1	B-2 B-6	9 9-1	○△	
880	Bレバー解除ビス B-lever release screw	1		12 12-1	○	
884-5	受板ビス JCIS ⊕ PM 1.7 x 3 Type (1) Screw	1	B-6	8-1	○△	
885	前小ギア取付ビス Screw	1	B-2	8	○△	
886	中間基板止めビス Screw	1	B-2	11	○△	
899	エブロン下ワッシャー Washer	1	B-2 B-6	7 7-1	○△	
904	MD スイッチ接片 A MD switch contact A	1	K	2	○△	
905	MD スイッチ接片 B MD switch contact B	1	K	2	○△	

部組品番号 No. of Sub-assembly	名 称 Name	1 台 備 数 Pcs. per Unit	構 成 部 品 番 号 No. of Constituent Parts	参照図番 Reference Fig. No.	備 考 Remarks
A29	クリックプーリー Click pulley	1	571, 576	12 12-1	
A30	シャッター Shutter	1	100, 579, 861, A29	12 12-1	
B-2 (01) (02)	前板部 Front plate	1	6, 54, 59, 61, 65-1, 83-5 202-5, 208x3, 216, 218 250, 261, 281, 281-1 283-1, 284, 291-5, 291A-5 291B-5, 313-5, 314, 320 321A,B,C, 328, 329, 330 331-1, 334, 336, 343-1, 348 349, 355-2, 357-5, 361, 367 368-5, 374, 375-5, 383-1 394, 395, 518A, 519x2 588, 589, 590, 594, 805x4 806x6, 808x2, 811-5x4, 813, 816, 817x2, 825-5x4 828x2, 834x2, 842M, 845-5x2, 854, 855, 858-5 877, 878A-5, 878B-5, 885 886, B1, B2, B3-1, B5-5, B6-5 B11, B14, B15, B16-5 B18-2, B19, B20-1, B21 B26-1, B27-1, B28-1, B30-1 B32	7 8 9 10 11	
B-6 (01) (02)	前板部 Front plate	1	6-6, 54, 59, 65-1, 202-5 208-6, 216, 218, 261, 291-5 291A-5, 291B-5, 302, 303 313-5, 314-6, 318-6, 320 321A,B,C, 328, 329, 330 331-5, 348, 349, 357-5, 361 374-6, 375-5, 383-1, 394, 395 518A, 519x2, 588-6, 589-6 590-6, 805x4, 808, 808A 811-5x4, 812-5, 813, 817x2 825-5x2, 828x2, 834x2, 842M, 854, 858-5, 863-5x3 877, 878A-5, 878B-5, 884-5 899, B1, B2-6, B3-6, B5-5, B6-5 B14, B15-6, B16-5, B19 B20-1, B26, B27-5, B28-6 B30-1, B32-6, B36-6, B38-5 B40-6, B39-5	7-1 8-1 9-1 10-1 11-1	
B2	セルフ連動レバー Self-timer coupling lever	1	18, 17	8	

部組品一覧表 Subassembly list

33FB-R-3001-A

部組品番号 No. of Sub-assembly	名称 Name	1台 個数 Pcs. per Unit	構成部品番号 No. of Constituent Parts	参照図番 Reference Fig. No.	備考 Remarks
B2-6	セルフ連動レバー Self-timer coupling lever	1	18, 17-6	8-1	
B3-1 (01) (02)	マウント台 Lens mount	1	201, 221-1, 222-1, 819-5x2 207, 209, 210, 211, 223 893x2	7	
B4-6 (01) (02)	絞り連動環 Aperture coupling ring	1	207-6, 209-6, 210-6 210A-5, 211-6, 223-6	7-1	
B5-5	着脱レバー Lens release lever	1	213-5, 212-5	7 7-1	
B6-5	着脱鈕 Lens release button	1	217-5, 214-5, 214A-5 215-5	10 10-1	
B11	大レバー Mirror change lever	1	333-1, 335, 369	11	
B12	ミラーアップレバー Mirror-up lever	1	322, 356x2, 378, 379-1 380, 381, 382	9	
B12-6	ミラーアップレバー Mirror-up lever	1	322-6, 356x2, 378-5 379-6, 380-6	9-1	
B13-1	ミラーダウンレバー Mirror-down lever	1	323, 325-1, 350, 358, 359 372, 375-5	9	
B15-1	5点セット Mirror actuating unit	1	340, 341, 344, 823A ~ D, B10, B12, B13-1, B17-5	9	
B16-5	45°ストッパー 45° stopper	1	337, 317-5, 339-5, 389 391	8 8-1	
B17-5	ミラーレバー軸取付板 Mirror lever base plate	1	377, 326-5	9 9-1	
B18-2	中間レバー基板 Mirror lever base plate	1	354, 352-2, 353	11	

部組品番号 No. of Sub- assembly	名 称 Name	1 台 個数 Pcs. per Unit	構成部品番号 No. of Constituent Parts	参照図番 Reference Fig. No.	備 考 Remarks
B19	リリースレバー Release lever	1	518, 519A	9 9-1	
B21	ダウンレバー調整レバー Down lever adjustor	1	362, 363, 364	11	
B26	ミラーチリトリ Mirror holder	1	301-1, 304, 305, 306x4 307, 308, 345, 346, 373-1x2 G1	10	
B26-6	ミラーチリトリ Mirror holder	1	301-1, 304, 305, 306x4 307-6, 308, 345, 346 373-1x2, G1	10-1	
B27-1	手動絞りレバー Stop-down coupling lever	1	310-1, 311-1	9 9-1	
B28-1	アイドルギア基板 Idle gear base plate	1	583-1, 585, 586, 591-1x2	9	
B28-6	アイドルギア基板 Idle gear base plate	1	583-6, 585, 586, 591-1x2	9-1	
B30-1 (01) (02)	前カバー銘板 Front cover	1	2-1, G9	7 7-1	
B32	絞り込みレバー Stop-down lever	1	309, 311A	9	
B32-6	絞り込みレバー Stop down lever	1	309-6, 311A-6	9-1	
B36-6	底基板 Bottom base plate	1	287-6, 270-5, 281-1, 282-6 283-5, 284-6, 334-5, 343-6 352-2, 353-6, 355-2, 362-6 363-6, 367-5, 368-5, B11-6	11-1	
B39-5	ミラーアップ受け Mirror-up support	1	265-5, 61	8-1	
B40-6	プリズムボックス Prism box	1	250-6, 251-6	8-1	

部組品一覧表 Subassembly list

33FB-R-3001-A

部組品番号 No. of Sub- assembly	名 称 Name	1 台 個数 Pcs. per Unit	構成部品番号 No. of Constituent Parts	参照図番 Reference Fig. No.	備 考 Remarks
C-1 (01) (02)	上 蓋 Top cover	1	3-1, 7-1, 69, 67-1, 68, 73 74A,B, 76, 78, 81, 404 468-1, 470, 478-1, 490A 491, 503, 535A, 535B 535C-1, 535D, 575-2, 577-2 856, 873x2, 874x2, C1-1 C3-1, C7	1	
C-6 (01) (02)	上 蓋 Top cover	1	3-6, 7-1, 67-1, 68, 69, 73 74A,Bx4, 76, 78, 81 404, 468-6, 469-6, 470-6 490A, 491, 493B, 503 535A, 535B, 575-2, 577-2 856, 873x2, 874x4, C1-1 C7	1-1	
C1-1	シュー座モールド Shoe mount mold	1	66-1, 75	1 1-1	
C3-1	かぶせリリース環 Release button cover ring	1	469-1, 471-1	1	
F-2	管制部 Functional control	1	541-2, 541A, 542-2, 543-3 544-1, 545-1, 546-1, 547-1 548-1, 548A-1, 549, 550-2 551, 555x2, 557-1, 558 559-1, 560, 561, 564-2 566-1, 567-1, 569-1, 572 574, 578-1, 614A-1, 680 869-2x3, 870x2	5-1	
F7-1	Tダイヤルプリー T-dial pulley	1	582-1, 599, 615-1, 616-1 617, 618-1, 619, 620, 621 622, 622A, 623	8 8-1	
H1-1	巻戻しレバー Rewind lever	1	654-1, 657, 658	6-1	
K	上地板 Upper-bracket	1	162, 164, 404A, 405-2, 409 411, 451, 477, 482x2 483x5, 483A-1, 484Ax2 485, 502-1, 505, 506, 507 508, 509, 512, 514, 520 521, 523, 526, 532-1, 533 534, 540Ax2, 540B 812-5x2, 831, 837, 904, 905 K4, K5, K6, P3-1	2	

部組品番号 No. of Sub-assembly	名 称 Name	1 台 個数 Pcs. per Unit	構 成 部 品 番 号 No. of Constituent Parts	参照図番 Reference Fig. No.	備 考 Remarks
K-6	上地板 Upper-bracket	1	126-5, 404A, 405-2, 451-6 409-6, 411, 472-6, 473-6 476-6, 477-6, 482-6x2, 483-6x5, 484-6, 485-6 487-6, 487A-5, 488-6 488A-5, 502-1, 505-6 508-6, 509-6, 510-6, 511-6 521-6, 522-6, 522A-5, 526 532-6, 533, 534-6, 540A-6 812A-5, 831-6, 844-5	2-1	
K4	スイッチレバー MD switch lever	1	484, 486-1	2	
M	IC プリント板 IC printed circuit	1	101, 102, 103, 104, 106x2 107, 108, 109, 112, 114 117, 118, 119, 120x2, 152 155, 155A, 156, 156A, 241 241A, 242, 258x2	6-1	
N1	ミラー保持基板 F-mirror holder	1	235, 236, 846x2, 875x2 G6x2	8 8-1	
N2	ペンタ押え Penta prism retainer	1	231, 239	8 8-1	
N4	接眼モールドメガネ Eyepiece mold	1	254-1, 255, 256-1, 257x2 259, 260, G4, G5, G8	8 8-1	
N6-5	フレネル受け枠 Focusing screen frame	1	263-5, 266-5, 267-5 268-5	8-1	
P3-1 (01) (02)	巻上レバー Wind-up lever	1	401-1, 401A-1, 495, 832x2	1 1-1	
P4	スイッチ制限 MD switch stopper	1	472, 474	2	

P33FB

部 品 表

Parts List

部品表 Parts List

P33FB-R-3001-A

部品番号 Part No.	名 称 Name	1 台 個 数 Pcs. per Unit	部組品No. Sub- assembly No.	参照図番 Reference Fig. No.	販 売 区 分 Term of Sale	備 考 Remarks
4 (01) (02)	底蓋 Bottom plate	1	D-1		△	
4A	底蓋遮光シート Bottom light baffle	1	D-1	14 14-1	○△	
8-1	接眼窓 Eyepiece ring	1	C4		△	
8A	接眼ゴム Eyepiece rubber	1	C4		△	
9	接眼ガラス押えばね Eyepiece glass clip	1	C4		△	31F3B #392
10	三脚座 Tripod socket	1		13 13-1	○	
11-1	吊環 Eyelet	2	A2-1		△	
12	耳スプリング Eyelet bush	2	A2 A2-1		△	32FB1 #12
13	ターミナルキャップ Terminal cap	1		6-1	○	32FB1 #15A S-3071
15	シンクロソケット Synch. socket	1		6-1	○	S-8504
16	セルフ指あて Self-timer lever knob	1	B-2 B-5 B1		△	
16A	セルフ作動レバー Self-timer lever	1	B-2 B-6 B1		△	
21-5	チャージレバー Charge lever	1	A6-5		△	
22	チャージレバーピン Charge lever pin	1	A6 A6-5		△	
11	吊環 Eyelet	2	A2		△	

部品表 Parts List

P33FB-R-3001-A

部品番号 Part No.	名 称 Name	1 台 個 数 Pcs. per Unit	部組品No. Sub- assembly No.	参照図番 Reference Fig. No.	販 売 区 分 Term of Sale	備 考 Remarks
23-5	チャージレバーローラ Charge lever roller	1	A6-5		△	
24	抜け止め座板 Washer	2	A4-1 A6 A6-5		△	
25-1	MD・SW運動レバー Motor switch coupling lever	1		12	○	
25-3	MD・SW運動レバー MD switch coupling lever	1		12-1	○	
26-1	空撮り防止レバー Blank exposure preventer lever	1		12	○	
26-2	空撮り防止レバー Blank exposure preventer lever	1		13-1	○	
28-1	MD信号レバー軸 MD signal lever axle	1		12	○	
28-2	MD信号レバー軸 MD signal lever axle	1		12-1	○	
29	空撮り防止レバー軸カラー Blank exposure preventer lever collar	1		12	○	
29-1	MD信号レバー座金 MD signal lever washer	1		12-1	○	
30-1(03) (04)	MD信号レバーばね MD signal lever spring	1		12	○	
31-1(03) (04)	底部押え板 Retaining plate, bottom	1		13	○	
31-2	底部押え板 Retaining plate, bottom	1		13-1	○	
32	シャッターチャージレバー Shutter charge lever	1	A4		△	

部品番号 Part No.	名 称 Name	1 台 個数 Pes. per Unit	部組品No. Sub- assembly No.	参照図番 Reference Fig. No.	販売区 区分 Term of Sale	備 考 Remarks
32-1	シャッターチャージレバー Shutter charge lever	1	A4-1		△	
33	ミラーチャージピン Mirror charge pin	1	A4		△	
33-1	ミラーチャージピン Mirror charge pin	1	A4-1		△	
35	ミラーチャージピンカラー Mirror charge pin collar	1	A4 A4-1		△	
37-1	シャッターチャージ爪 Shutter charge claw	1	A4 A4-1		△	
38-1	チャージ爪かしめピン Rivet shutter charge pin	1	A4 A4-1		△	
43-2	電池ケース Battery chamber	1	A5-2		△	
44	電池キャップ Battery chamber cap	1	P5		△	S-3726A
45-1	電池アース接片 Battery chamber earth contact	1		13 13-1	○	
46	電池ホルダー Battery holder	1	P5		△	S-3104
47	電池⊕接片A Battery contact A ⊕	1	A5 A5-2		△	
48	電池接片かしめ紙 Battery contact rivet	1	A5 A5-2		△	
49	電池⊕接片B Battery contact B ⊕	1	A5 A5-2		△	
50	ローラー Roller	1		15-1	○	

部品表 Parts List

P33FB-R-3001-A

部品番号 Part No.	名 称 Name	1 台 個 数 Pcs. per Unit	部組品No. Sub- assembly No.	参照図番 Reference Fig. No.	販売 区分 Term of Sale	備 考 Remarks
51	ローラー軸 Roller shaft	1		15-1	○	
54 (01) (02)	セルフレバービス Self-timer lever screw	1	B2 B-6	8 8-1	○△	
55	セルフレバー用革 Leatherette	1		8 8-1	○	
58-1	溝用モルトブレン Light-tight (for groove)	1		15-1	○	
58A-1	上溝用モルトA Light-tight A	1		15-1	○	
58B-1	上溝用モルトB Light-tight B	1		15-1	○	
59	ミラーボックス下部モルト Mirror box bottom buffer	1	B-2 B-6	10 10-1	○△	
60	接眼下部遮光モルト Light-tight (for eyepiece)	1	B-2 B-6	12 12-1	○△	
63	シャッター羽根受けゴム Shutter curtain rubber	1	B-2 B-6	12 12-1	○	
64	緩衝ゴムA Shock absorb rubber A	1		13 13-1	○	
65-1 (01) (02)	小ねじ JCIS ⊕ PM 1.7 x 2.2 Type (1) Screw	1	B-2 B-6	7 7-1	○△	
69	押え接点 Upper shoe switch contact	1	C-1 C-6	1 1-1	○△	
70-1	受け接点 Lower shoe switch contact	1	C C7		△	
71-1	接点モールド Contact mold	1	C C7		△	

部品表 Parts List

P33FB-R-3001-A

部品番号 Part No.	名 称 Name	1 台 個 数 Pcs. per Unit	部組品No. Sub- assembly No.	参照図番 Reference Fig. No.	販 売 区 分 Term of Sale	備 考 Remarks
73	押棒 Switch plunger	1	C-1 C-6	1 1-1	○△	31F3B #575
74A	シュー座金 (1.8×3×0.15) Shoe washer	4	C-1 C-6	1 1-1	○△	
74B	シュー座金 (1.8×3×0.3) Shoe washer	4	C-1 C-6	1 1-1	○△	
75	シンクロ接点 Synch. contact	1	C C-1		△	
82-1	シャッター上遮光モルト Light-tight, shutter top	1		12 12-1	○	
83-5	ミラーボックス後部遮光ゴム Mirror box rear light rubber	1	B-2 B38		△	
85-1	シャッターチャージレバー受ゴム Charge lever base rubber	1		13 13-1	○	
86-5	M. BOX 後部遮光板 Mirror box rear light-baffle	1	B-2 B-6 B38 B38-5		△	
97-1	空撮り防止作動ばね Blank exposure preventer spring	1		13-1	○	
98-1	空撮り防止レバー軸 Blank exposure preventer lever axle	1		13-1	○	
126-5	上地スイッチコード Switch cord	1	K-6	2-1	○△	Orange, Purple, Red x 220mm
202	バイヨネット環 Bayonet	1	B-2	7	○△	
202-5	バイヨネット環 Bayonet	1	B-6	7-1	○△	
208	バイヨネットばね Bayonet spring	3	B-2	7	○△	32FBI #208 S-1531

部品番号 Part No.	名称 Name	1台 個数 Pcs. per Unit	部組品 No. Sub- assembly No.	参照図番 Reference Fig. No.	販売 区分 Term of Sale	備 考 Remarks
208-6	バイヨネットばね Bayonet spring	1	B-6	7-1	○△	
209	絞り連動片 Aperture coupling piece	1	B-2 B4		△	
209-6	絞り連動片 Aperture coupling piece	1	B-6 B4		△	
210	絞り連動片ばね Coupling piece spring	1	B-2 B4	8	○△	
210-6	絞り連動片ばね Coupling piece spring	1	B-6 B4-6		△	
211	絞り連動片軸 Coupling piece shaft	1	B-2 B4		△	
211-6	絞り連動片軸 Coupling piece shaft	1	B-6 B4-6		△	
216	着脱ボタンばね Lens release button spring	1	B-6		△	32FB1 #216
218	着脱ボタン軸受 Lens release button sleeve	1	B-6		△	
223	連動片ばねボタン Coupling piece spring button	1	B-2 B4	7	○△	
223-6	連動片ばねボタン Coupling piece spring button	1	B-6 B4-6		△	
255	接眼レンズ押え板 Eyepiece retainer	1	N4		△	
257	絞り板 Diaphragm plate	2	N4		△	32FB #257 32FBI #257
261	レンズ着脱ボタン飾 Lens release button pad	1	B-2 B-6	10 10-1	○△	32FBI #269

部品表 Parts List

P33FB-R-3001-A

部品番号 Part No.	名 称 Name	1 台 個 数 Pes. per Unit	部組品No. Sub- assembly No.	参照図番 Reference Fig. No.	販 売 区 分 Term of Sale	備 考 Remarks
270-5	グリップリング Grip ring	1	B-6 B36-6	11-1	○△	
281-1	保持レバー Retaining lever	1	B-6 B36-6	11-1	○△	
282	ブレーキ解除軸 Brake release axle	1	B-2		△	
282-6	ブレーキ解除軸 Brake release axle	1	B-6 B36-6		△	
283-5	グリップリング Grip ring	1	B-6 B36-6	11-1	○△	
284-6	ブレーキ解除軸ビス Brake release shaft screw	1	B-6 B36-6	11-1	○△	
287-1	M. BOX下部基板 Mirror box bottom base plate	1	B-1 B37-1		△	
287-6	M. BOX下部基板 Mirror box bottom base plate	1	B-6 B36-6		△	
288	ミラーダウン信号レバー Mirror-down signal lever	1	B-2 B14		△	
288-1	ミラーダウン信号レバー Mirror-down signal lever	1	B-2 B-6	9-1	○△	
289-1	ミラー係止レバーばね Mirror-holder lever spring (d=0.26)	1	B-2 B-6 B14	9 9-1	○△	
290	係止レバーばねかけピン Spring retaining pin	1	B-2 B14		△	

部品表 Parts List

P33FB-R-3001-A

部品番号 Part No.	名 称 Name	1 台 個数 Pcs. per Unit	部組品No. Sub- assembly No.	参照図番 Reference Fig. No.	販売 区分 Term of Sale	備 考 Remarks
301-1	ミラーチリトリ Mirror holder	1	B-2 B-6 B26 B26-6		△	
306	チリトリ駆動板カシメピン Caulking pin	4	B-2 B-6 B26 B26-6		△	
307	チリトリピンA Mirror holder pin A	1	B-2 B26		△	
307-6	チリトリピンA Mirror holder pin A	1	B-6 B36-6		△	
310-1	手動絞りレバー Manual stop-down lever	1	B-2 B-6 B27 B27-5		△	
311-6	手動絞りレバー軸 Manual stop-down lever axle	1	B-2 B-6 B27 B27-5		△	
312	手動絞りレバーピン Manual stop-down lever pin	1	B-2 B-6 B10		△	
313-5	手動絞りレバーばね Manual stop-down lever spring	1	B-2 B-6	9 9-1	○△	
315	絞りレバー Diaphragm actuating lever	1	B-2 B-6 B10		△	
316	絞りレバーばね掛け Diaphragm actuating lever spring mount	1	B-2 B-6 B10		△	
317	45° ストッパー 45° stopper	1	B-2 B16		△	
318-6	手動絞りレバー座 Manual stop-down lever plate	1	B-2 B-6	9 9-1	○△	
320A	チャージレバー軸 Charge lever axle	1		12 12-1	○	
323-6	ミラーダウンレバー Mirror-down lever	1	B-6 B13-6		△	

部品表 Parts List

P33FB-R-3001-A

部品番号 Part No.	名 称 Name	1 台 個 数 Pcs. per Unit	部組品No. Sub- assembly No.	参照図番 Reference Fig. No.	販売区 区分 Term of Sale	備 考 Remarks
324-1	アップレバー軸筒 Mirror-up lever tube	1	B-6 B33-2		Δ	
325-1	ダウンレバー軸筒 Mirror-down lever tube	1	B-2 B-6 B13 B13-6		Δ	
326A	ミラーレバー軸ワッシャー(4.6×7×0.05) Mirror lever shaft washer	1	B-2 B-6 B15-7	9 9-1	○Δ	
328	シグナルレバー Signal lever	1	B-2 B-6 B15-7	9 9-1	○Δ	
330	ミラーダウン係止レバー Mirror-down latch lever	1	B-2 B-6	9 9-1	○Δ	
333-1	大レバー Mirror charge lever	1	B-2 B11		Δ	
333-6	大レバー Mirror charge lever	1	B-6 B11-6 B36-6		Δ	
334-5	大レバー軸 Mirror charge level axle	1	B-2 B-6 B37-1 B36-6		Δ	
335-5	大レバー軸ブッシュ Bush	1	B-2,B-6 B11 B11-6 B36-6		Δ	
340	絞りレバーばね Diaphragm actuating lever spring	1	B-2 B-6 B15-7	9 9-1	○Δ	
341	ミラーアップばね Mirror-up spring	1	B-2 B-6 B15-7	9 9-1	○Δ	
344-5	レバー押えビス Mirror holder screw	1	B-2 B-6 B15-7	9 9-1	○Δ	
345	ミラー押えA Mirror holder A	1	B-2 B-6 B26 B26-6		Δ	
346	ミラー押えB Mirror holder B	1	B-2 B-6 B26 B26-6		Δ	

部品表 Parts List

P33FB-R-3001-A

部品番号 Part No.	名 称 Name	1 台 個数 Pcs. per Unit	部組品No. Sub- assembly No.	参照図番 Reference Fig. No.	販売区 区分 Term of Sale	備 考 Remarks
350-5	ミラーアップレバー止めピン Mirror-up lever pin	1	B-2 B-6 B13 B13-6		Δ	
352-2	MD巻き上げ信号中間レバー MD take-up signal middle lever	1	B-2 B-6 B36-6	11 11-1	○Δ	
353-6	MD巻き上げ中間レバー軸 MD take-up middle lever axle	1	B-6 B36-6		Δ	
355-2	保持レバーばね(d = 0.4) Spring	1	B-6 B36-6	11-1	○Δ	
356	調整ピン Adjusting pin	2	B-6 B12-6 B15-7		Δ	
358-6	ダウンレバー連結軸 Down lever connecting shaft	1	B-6 B13-6 B15-7		Δ	
359	連結軸ブッシュ Connecting shaft bush	1	B-2 B13		Δ	
362-6	ダウンレバー調整レバー Down lever adjusting lever	1	B-6 B21-6 B36-6		Δ	
363-6	ダウンレバー緩衝ゴム Shock absorb rubber	1	B-6 B36-6	11-1	○Δ	
367-5	ダウンレバー調整軸 Down lever adjusting axle	1	B-6 B36-6		Δ	
368-5	ダウンレバー調整レバー軸 Down lever adjusting axle	1	B-6 B36-6		Δ	
369	ダウンばね掛ピン Spring retaining pin	1	B-2 B11		Δ	
372	防振用ゴム Cushion rubber	1	B-2 B13-1 B-6 B13-6	9 9-1	○Δ	
373-1	ミラー押えかしめピン Mirror retainer rivet	2	B-2 B-6 B26 B26-6		Δ	

部 品 表 Parts List

P33FB-R-3001-A

部品番号 Part No.	名 称 Name	1 台 個 数 Pcs. per Unit	部組品No. Sub- assembly No.	参照図番 Reference Fig. No.	販 売 区 分 Term of Sale	備 考 Remarks
375-5	ミラー巻上側ワッシャ Washer	1	B-2 B-6	10 10-1	○△	
376-1	絞りレバーばね掛 Diaphragm actuating lever spring stud	1	B-2 B-6 B32-2		△	
378-5	ミラーสปリング大 (d = 0.45) Mirror spring (L)	1	B-2 B-6 B12 B12-6	9 9-1	○△	
379-1	ミラーสปリング小 (d = 0.28) Mirror spring (S)	1	B-2 B12	9	○△	
379-6	ミラーสปリング小 Mirror spring (S)	1	B-6 B12-6	9-1	○△	
380	ミラーสปリング大軸 Mirror spring axle (L)	1	B-2 B12		△	
380-6	ミラーสปリング軸 Mirror spring axle	1	B-6 B12-6		△	
381	ミラーสปリング小軸 Mirror spring axle (S)	1	B-2 B12		△	
383	エアダンパー駆動レバー Air damper lever	1	B-2	10	○△	
383-1	エアダンパー駆動レバー Air damper lever	1	B-6	10-1	○△	
385-1	エアダンパー駆動レバー受ピン Air damper lever pin	1	B-2 B20		△	
386-2	エアダンパー接続棒 Air damper connecting shaft	1	B-2 B20		△	
386-3	エアダンパー接続棒 Air damper connecting shaft	1	B-6 B20-1		△	
387	エアダンパーピストン Air damper piston	1	B-2 B-6 B20 B20-1		△	

部品表 Parts List

P33FB-R-3001-A

部品番号 Part No.	名 称 Name	1 台 個数 Pcs. per Unit	部組品No. Sub- assembly No.	参照図番 Reference Fig. No.	販売区 分 Term of Sale	備 考 Remarks
388	エアードンパーシリンダー Air damper cylinder	1	B-2 B-6 B20 B20-1		△	
389	45°出しレバー軸 45° adjusting pin	1	B-2 B-6 B16 B15-7		△	
391	45° 出し調整ピン 45° adjusting pin	1	B-2 B-6 B16 B15-7		△	
392	エアードンパーシリンダー蓋 (A) Air damper cylinder cover (A)	1	B-2 B-6 B20 B20-1		△	
393-2	エアードンパーシリンダー蓋 (B) Air damper cylinder cover (B)	1	B-2 B-6 B20 B21		△	
394	エアードンパーホルダー Air damper holder	1	B-2 B-6	10 10-1	○△	
395	エアードンパー駆動レバー止ビス Air damper lever screw	1	B-2 B-6	10 10-1	○△	
397-1	エアードンパーゴム Air damper rubber	1	B-2 B-6 B20 B20-1		△	
401-1 (01)(02)	巻上レバー Film-advance lever	1	P3-1		△	
402	巻上レバー用皮 Wind-up lever leatherette	1		1 1-1	○	
403-1 (01)(02)	レバー押えねじ Wind-up lever screw	1		1 1-1	○	
405-2	レバー軸ナット Lever axle nut	1	K K-6	2 2-1	○△	
408	巻上軸 Film-advance shaft	1		2 2-1	○	
408A	スプロケット制限除板 Sprocket stopper release plate	1		2 2-1	○	

部品表 Parts List

P33FB-R-3001-A

部品番号 Part No.	名 称 Name	1 台 個 数 Pcs. per Unit	部組品No. Sub- assembly No.	参照図番 Reference Fig. No.	販 売 区 分 Term of Sale	備 考 Remarks
409	レバー軸受 Lever shaft bearing	1	K		△	
409-6	レバー軸受 Lever shaft bearing	1	K-6		△	
411	クリックレバー Click lever	1	K K-6		△	
412	三羽根爪押えばね Charge cam claw retaining spring	3	A18	3	○△	
412-6	面カム板ばね Clutch cam spring	1		3-1	○	
412B	三羽根爪軸 Charge cam claw shaft	6	A18		△	
413	巻上げカム Film advance cam	1		3	○	
413-6	巻上げカム Film advance cam	1		3-1	○	
414	三羽根爪 Charge cam claw	3	A18		△	
414A-5	面カムピン Clutch pin	1	A13-6		△	
414B-5	面カムねじりばね(d = 0.2) Clutch spring	1		3-1	○	
414-6	面カム板 Clutch cam	1	A13-6		△	
415	巻上ギア Advance gear	1	A18		△	
415-6	巻上ギア Advance gear	1		3-1	○	

部品表 Parts List

P33FB-R-3001-A

部品番号 Part No.	名称 Name	1台 個数 Pcs. per Unit	部組品No. Sub- assembly No.	参照図番 Reference Fig. No.	販売 区分 Term of Sale	備 考 Remarks
416-1	アイドルギアA Idle gear A	1	A11 A11-6		△	
417-2	アイドルギアB Idle gear B	1	A11		△	
417-6	アイドルギアB Idle gear B	1	A11-6		△	
418	アイドルギアC Idle gear C	1	A11		△	
419	アイドルギアC軸 Idle gear C shaft	1	A11		△	
420-1	スプール上ギア Spool top gear	1	A7		△	
421	スプール上ギアナット Spool top gear nut	1	A7		△	32FB1 #429A (~ 8)
422	巻上軸受ケース Film advance bearing case	1	A11		△	
422-6	巻上軸受ケース Film advance bearing case	1	A11-6		△	
423	ボール保持筒 Steel ball holding tube	2	A14 A11 A11-6		△	
424-1	スプールギア内筒 Spool gear inner tube	1	A7		△	
425	アイドルギア軸受ケース Idle gear bearing case	1	A11 A11-6		△	
426	軸受ケースカシメピン Bearing case caulking pin	3	A11 A11-6		△	
427	アイドルギアAワッシャ Idle gear A washer	1	A11 A11-6		△	

部品表 Parts List

P33FB-R-3001-A

部品番号 Part No.	名 称 Name	1 台 個 数 Pcs. per Unit	部組品No. Sub- assembly No.	参照図番 Reference Fig. No.	販 売 区 分 Term of Sale	備 考 Remarks
429	スプロケット制限カム Sprocket stopper cam	1		4 4-1	○	
431	スプロ上ギア Sprocket upper gear	1		4	○	
431-6	スプロ上ギア Sprocket upper gear	1		4-1	○	
432	スプロケット上軸受 Sprocket shaft bearing	1		4	○	
432-6	スプロケット上軸受 Sprocket shaft bearing	1		4-1	○	
433	スプロケットカラー Sprocket collar	1		4	○	
434	スプロケット軸 Sprocket shaft	1		4	○	
434-6	スプロケット軸 Sprocket shaft	1		4-1	○	
435	スプロケットビス Sprocket screw	1		4 4-1	○	
435A	スプロケットビスA Sprocket screw A	1		4 4-1	○	
436-1	スプロケットローラーA Sprocket roller A	1		4 4-1	○	
437	スプロカラーAナット Sprocket collar A nut	1		4 4-1	○	
438	スプロ軸受 Sprocket shaft bearing	1		4	○	
438-6	スプロ下軸受 Sprocket shaft bearing	1		4-1	○	

部品表 Parts List

P33FB-R-3001-A

部品番号 Part No.	名 称 Name	1 台 個 数 Pcs. per Unit	部組品No. Sub- assembly No.	参照図番 Reference Fig. No.	販 売 区 分 Term of Sale	備 考 Remarks
439	巻戻釦 Rewind button	1	D-1	13 13-1	○△	
440	逆点止爪軸 Anti-reversing claw shaft	1	A11 A11-6		△	
441	三羽根爪外しレバー軸 Charge cam claw release lever axle	1		12	○	
441-6	面カム外しレバー軸 Clutch cam release lever axle	1		12-1 13-1	○	
443	逆転止爪 A Anti-reversing claw A	1	A11 A11-6		△	
444	逆転止爪 B Anti-reversing claw B	1	A11 A11-6		△	
445	逆転防止爪ばね Anti-reversing claw spring	1	A11 A11-6		△	
446A-5	逆転防止爪ばねカシメピン Caulking pin	1	A11 A11-6		△	
447	スプロストッパー Sprocket stopper	1	A12		△	
447-6	スプロストッパー Sprocket stopper	1	A12-6		△	
448	スプロストッパー軸 Sprocket stopper axle	1	A11 A11-6		△	
449	ストッパーブッシュ Sprocket stopper bush	1	A12 A12-6		△	
450	スプロストッパー戻しばね (d = 0.3) Sprocket stopper returning spring	1	A11 A11-6	3 3-1	○△	
451-6	上地板 Upper base plate	1	K-6		△	

部 品 表 Parts List

P33FB-R-3001-A

部品番号 Part No.	名 称 Name	1 台 個 数 Pcs. per Unit	部組品No. Sub- assembly No.	参照図番 Reference Fig. No.	販 売 区 分 Term of Sale	備 考 Remarks
452	下地板 Lower base plate	1	A11		△	
452-6	下地板 Lower base plate	1	A11-6		△	
453	スプール軸 Spool shaft	1	A9		△	
454	スプール軸受ケース Spool shaft bearing shaft	1	A11		△	
455	スプール内筒 Spool inner tube	1	A8		△	
455A	スプール座金 Spool washer	1	A8		△	32FB1 #436-2
456-1	フリクション板 Friction plate	1	A7		△	
456A	フリクションばね Friction spring	1	A7		△	
456B-1	ばね受け皿 Spring tray	1	A7		△	
456C	ばね押え筒 Spring retaining tube	1	A9		△	32FB1 #499
457	ボールケース Ball case	2	A11 A11-6 A14		△	
458	セットカムピン Set cam pin	1	A10A-1 A10B-2		△	
459-1	セットカム Set cam	1	A10A-1 A10B-2		△	
460	セットカムカラー Set cam collar	1		4 4-1	○	32FB1 #491-1

部品表 Parts List

P33FB-R-3001-A

部品番号 Part No.	名 称 Name	1 台 個 数 Pcs. per Unit	部組品No. Sub- assembly No.	参照図番 Reference Fig. No.	販 光 区 分 Term of Sale	備 考 Remarks
461	カップリング支柱 Coupling strut	1	A10A-1 A10B-2		△	
462	振り子 Pendulum	1		14 14-1	○	
464	ロックレバー Lock lever	1		13 13-1	○	
465	ロックレバーばね Lock lever spring	1		13 13-1	○	
467-1	ゆるみ止めカラー Collar	1		4 4-1	○	
469	かぶせリリース環 Release ring	1	C3-1 C-1	1	○△	
469-6	かぶせリリース環 Release ring	1	C-6	1-1	○△	
472	スイッチ制限軸 MD switch stopper axle	1	P4		△	
472-6	スイッチ制限軸 MD switch stopper axle	1	K-6		△	
473	スイッチ制限軸 Switch stopper axle	1		2	○	
477	スイッチ制限ストッパー Switch stopper	1	K		△	
473-6	スイッチ制限軸 Switch stopper axle	1	K-6		△	
476-6	スイッチばね (d = 0.35) Switch spring	1	K-6		△	
477-6	スイッチばね軸 Switch spring axle	1	K-6		△	

部 品 表 Parts List

P33FB-R-3001-A

部品番号 Part No.	名 称 Name	1 台 個 数 Pcs. per Unit	部組品No. Sub- assembly No.	参照図番 Reference Fig. No.	販 売 区 分 Term of Sale	備 考 Remarks
482	巻上制限ピン Film advance stopper pin	2	K		Δ	
482-6	巻上制限ピン Film advance stopper pin	2	K-6		Δ	
483	クリックレバーばね Click lever spring	5	K	2	○Δ	
483-6	クリックレバーばね Click lever spring	5	K-6	2-1	○Δ	
483A-1	クリップレバーばね座板 Click lever spring washer	1	K		Δ	
484	スイッチレバー Switch lever	1	K		Δ	
484-6	スイッチレバー Switch lever	1	K-6		Δ	
484A-1	座板カシメピン Caulking pin	2	K		Δ	
485	スイッチレバーカラー Lever switch collar	1	K		Δ	
485-6	スイッチレバー軸 Switch lever axle	1	K-6		Δ	
487	主スイッチ切片A Lever switch contact A	1	A11	3	○Δ	
487A-5	ブラシ当板 Brush plate	1	K-6		Δ	
487-6	スイッチブラシ Switch brush	1	K-6		Δ	
488	主スイッチ切片B Lever switch contact B	1	A11	3	○Δ	

部品表 Parts List

P33FB-R-3001-A

部品番号 Part No.	名 称 Name	1 台 個 数 Pcs. per Unit	部組品No. Sub- assembly No.	参照図番 Reference Fig. No.	販売 区分 Term of Sale	備 考 Remarks
488-6	スイッチプリントシート Switch printed sheet	1	K-6		△	
488A-5	プリントシートカシメピン Printed sheet pin	1	K-6		△	
489	三羽根爪外レバー Charge cam claw release lever	1		12	○	
489-6	面カム外しレバー Clutch cam release lever	1		12-1	○	
489A	面カム外しレバー座金 Washer	1		12-1	○	
495	指あて Wind-up lever knob	1	P3-1	1 1-1	○△	32FB1 #416
496	スプロケット板ばね Sprocket stopper spring	1	A11	3	○△	
496-6	スプロケット板ばね Sprocket stopper spring	1	A11-6	3-1	○△	
497	鋼 球 Steel ball	48	A7 A11-6 A14		△	32FB1 #493
498	スプロケットばね (d = 0.35) Sprocket spring	1		4 4-1	○	32FB1 #444
499-1	スプロケット軸カラー Sprocket shaft collar	1		4	○	
502-1	枚数計 Frame-counter dial	1	K K-6	2 2-1	○△	
505	カウンターばね (d = 0.26) Counter spring	1	K	2	○△	
505-6	カウンターばね (d = 0.26) Counter spring	1	K-6	2-1	○△	

部品表 Parts List

P33FB-R-3001-A

部品番号 Part No.	名称 Name	1台 備数 Pcs. per Unit	部組品No. Sub- assembly No.	参照図番 Reference Fig. No.	販売 区分 Term of Sale	備 考 Remarks
506	止爪 Ratchet claw	1	K	2	〇Δ	
507	止爪ナット Ratchet claw nut	1	K	2	〇Δ	
508	止爪カラー Ratchet claw collar	1	K	2	〇Δ	
508-6	零戻しレバーナット Counter reverse lever nut	1	K-6	2-1	〇Δ	
509	クリックレバー軸 Click lever axle	1	K		Δ	
509-6	クリックレバーカラー Click lever collar	1	K-6	2-1	〇Δ	
510-1	送り爪ギア Advance claw gear	1	K K-5		Δ	
510-6	送り爪ギア Advance claw gear	1	K-6	2-1	〇Δ	
511-1	送り爪レバー Advance claw lever	1	K K5		Δ	
511-6	カウンタ運動ギア Counter gear	1	K-6	2-1	〇Δ	
512	送り爪レバー軸 Advance claw lever axle	1	K	2	〇Δ	
513-1	送り爪軸 Advance claw axle	1	K K5		Δ	
514	送り爪レバー軸カラー Advance claw lever axle collar	1	K	2	〇Δ	
515-1	ばね掛けピン Spring retaining pin	1	K K5		Δ	

部品番号 Part No.	名 称 Name	1 台 個数 Pcs. per Unit	部組品No. Sub- assembly No.	参照図番 Reference Fig. No.	販売 区分 Term of Sale	備 考 Remarks
516-1	カウンター送り偏心軸 Counter advance eccentric shaft	1	A11		△	
517	偏心軸軸受 Eccentric shaft bearing	1	A11		△	
520	零戻しばねワッシャー Resetting spring washer	1	K		△	
521	零戻しばね (d = 0.26) Resetting spring	1	K	2	○△	
521-6	送り爪ばね Claw spring	1	K-6	2-1	○△	
522	零戻しレバー Counter reset lever	1	K K6		△	
522-6	零戻しレバー Counter reset lever	1	K-6	2-1	○△	
522A-5	零戻しレバーばね (d = 0.3) Counter reset lever spring	1	K-6	2-1	○△	
523	零戻しレバー軸 Counter reset lever axle	1	K	2	○△	
524	爪外しピン Claw release pin	1	K K6		○△	
526	クリックレバーあおり止め Click lever stopper	1	K		△	
527A	リリース軸補助 Release shaft supporter	1		12 12-1	○	
527B-1	リリース鉤補助ばね (d = 0.14) Spring (d=0.14)	1		12 12-1	○	
528	スプール Spool	1	A8		△	

部品表 Parts List

P33FB-R-3001-A

部品番号 Part No.	名 称 Name	1 台 個数 Pcs. per Unit	部組品No. Sub- assembly No.	参照図番 Reference Fig. No.	販売区 区分 Term of Sale	備 考 Remarks
529	スプール軸ばね Spool shaft spring (d=0.4)	1	A9		△	
530A	ラチェットカム Ratchet cam	1	A10A-1		△	
530B-1	ラチェットカム Ratchet cam	1	A10B-2		△	
531	スプロケット Sprocket	1		4	○	
531-6	スプロケット Sprocket	1		4-1	○	
532-1	ラチェット Ratchet	1	K	2	○△	
532-6	ラチェット Ratchet	1	K-6	2-1	○△	
533	指標板 Frame-counter index	1	K	2 2-1	○△	
534	スイッチ押え板 MD switch cover	1	A11	3	○△	
534-6	スイッチ押え板 MD switch cover	1	K-6		△	
535A	リリース釦 Release button	1	C	1 1-1	○△	32FB1 #459-2
535B	リリースガイドビス Release guide screw	1	C	1 1-1	○△	
536	リリース軸ばね Release shaft spring (d=0.35)	1		12 12-1	○	
537	ARレバー AR lever	1		13	○	

部品番号 Part No.	名 称 Name	1 台 個 数 Pcs. per Unit	部組品No. Sub- assembly No.	参照図番 Reference Fig. No.	販 売 区 分 Term of Sale	備 考 Remarks
537-6	A R レバー AR lever	1		13-1	○	
537A	A R レバー軸 AR lever axle	1		13	○	32FB1 #480
537B	A R レバーばね AR lever spring (d=0.18)	1		13	○	
538	振り子偏心軸 Pendulum eccentric axle	1		13 13-1	○	
538A	振り子ばね Pendulum spring (d=0.16)	1		13 13-1	○	32FB1 #484
539	ロックレバー軸 Lock lever axle	1		13 13-1	○	32FB1 #487
540	R 錠スリーブ Rewind button sleeve	1	D D-1		△	
540A	MD スイッチ絶縁板 MD switch insulation plate	4	A11 K	2 3	○△	
540A-6	スイッチ絶縁板 Switch insulation plate	1	K-6		△	
654-1	巻戻レバー Rewind crank	1	A1-1		△	
656	レバー受ばね Rewind crank spring	1		6-1	○	
666-1	巻戻しレバー軸 Rewind crank shaft	1		6-1	○	
680	F R E FRE	1	F2		△	
701-1	裏 蓋 Camera back	1	E1		△	

部品表 Parts List

P33FB-R-3001-A

部品番号 Part No.	名 称 Name	1 台 個数 Pcs. per Unit	部組品No. Sub- assembly No.	参照図番 Reference Fig. No.	販売 区分 Term of Sale	備 考 Remarks
702-2	圧板 Pressure plate	1	E2		△	
703	圧板ばね Spring	1	E2		△	32FB1 #703
704-2	圧板紙 Rivet	2	E2		△	S-1128A
705	圧板ばね支え紙 Pressure plate spring stud	4	E1		△	
707	止め爪A Latch A	1	E1		△	32FB1 #707
709	止め爪カバー Latch cover	1		15-1	○	
710	蝶板芯金A Hinge shaft	1	E1		△	
711	止め爪用紙 Latch rivet	2	E1		△	
712	パトローネ押えカシメピン Rivet	3	E1		△	
714	止め爪ばね (d = 0.35) Latch spring	1		15-1	○	
715	パトローネ押え Cartridge press spring	1	E1		△	
716	ローラ受け板 Roller bracket	1	E1		△	
717	ローラ受け板紙 Roller bracket rivet	2	E1		△	
718	ローラー Roller	1	E1		△	

部品表 Parts List

P33FB-R-3001-A

部品番号 Part No.	名称 Name	1台 備数 Pcs. per Unit	部組品No. Sub- assembly No.	参照図番 Reference Fig. No.	販売区 分 Term of Sale	備考 Remarks
719	裏蓋遮光板 Camera back light baffle	1	E1		△	32FB1 #719
720	裏蓋蝶番B Camera back hinge B	1	E1		△	
721	裏蓋蝶番Bカンメピン Camera back hinge B rivet	7	E1		△	
722	蝶番芯金B Hinge shaft B	1	E1	14-1	○△	
723-1	メモホルダー枠 Memo holder frame	1	E1		△	
725	裏蓋用貼革 Back cover leatherette	1	E1	14-1	○△	
726	遮光モルトA Light-tight A	1	E1	14-1	○△	
727	遮光モルトB Light-tight B	1	E1	14-1	○△	
728	遮光モルトC Light-tight C	1	E1	14-1	○△	
730	遮光別珍B Light-baffle cloth B	2	E1	14-1	○△	
731	裏蓋着脱ピン Camera back release pin	1	E1	14-1	○△	
732	裏蓋着脱ばね (d = 0.26) Camera back release spring	1	E1	14-1	○△	30FB #629 S-1589
801	小ねじ JCIS ⊕ PM 2.0 x 3.0 Type (3) Screw	3		13, 13-1	○	
802	小ねじ JCIS ⊕ PM 2.0 x 7.0 Type (1) Screw	1		12 12-1	○	

部品表 Parts List

P33FB-R-3001-A

部品番号 Part No.	名 称 Name	1 台 個 数 Pes. per Unit	部組品No. Sub- assembly No.	参照図番 Reference Fig. No.	販売 区 分 Term of Sale	備 考 Remarks
803 ⁽⁰¹⁾ (02)	小ねじ JCIS ⊕ PM 1.7 x 3.0 Type (1) Screw	5		1 1-1	○	
804A ⁽⁰¹⁾ (02)	小ねじ JCIS ⊕ CM 1.7 x 2.5 Type (1) Screw	3		13 13-1	○	
804B	小ねじ JCIS ⊕ CM 1.7 x 2.5 Type (1) Screw	3		15-1	○	
805	バイヨネット止ビス Bayonet set screw	4	B-2 B-6	7 7-1	○△	32FB #805
810	前板取付ビス Front plate screw	8		8, 8-1 13, 13-1	○	32FB #810
812-5	小ねじ JCIS ⊕ PM 1.7 x 2.5 Type (1) Screw	1	B-6	8-1	○△	
812A-5	小ねじ JCIS ⊕ PM 1.7 x 2.0 Type (3) Screw	1	K-6	2-1	○△	
813 ⁽⁰¹⁾ (02)	前カバービス ⊕ PM 1.7 x 3 Screw	1	B-1 B-6	7 7-1	○△	
815-5	巻上軸ビス (左ねじ) ⊖ PM 2 x 3 Film-advance shaft screw (left-handed)	1		3 4,4-1	○	S-0206A
815A-5	巻上軸ビス Film-advance shaft screw	1		3-1	○	
817	小ねじ JCIS ⊕ PM 2.0 x 5.0 Type (3) Screw	4		8, 8-1 10, 10-1	○	
820	カップリングビス Coupling screw	1		4 4-1	○	32FB1 #932
821	小ねじ JCIS ⊕ PM 2.0 x 4.0 Type (3) Screw	2		13 13-1	○	
823A	ミラーレバー軸調整用座金 Washer	1	B-6 B15-6	9 9-1	○△	

部品表 Parts List

P33FB-R-3001-A

部品番号 Part No.	名称 Name	1台 個数 Pcs. per Unit	部組品No. Sub- assembly No.	参照図番 Reference Fig. No.	販売区 区分 Term of Sale	備考 Remarks
823B	ミラーレバー軸調整用座金 Washer	1	B-6 B15-6	9 9-1	○△	
823C	ミラーレバー軸調整用座金 Washer	1	B-6 B15-6	9 9-1	○△	
823D	ミラーレバー軸調整用座金 Washer	1	B-6 B15-6	9 9-1	○△	
824	ギアセットビス Gear set screw	7	A7	4,4-1	○△	32FB #824
825-5	小ねじ JCIS ⊕ PM 2.0 x 2.5 Type (1) Screw	6	B-2 B-6	9 10, 10-1 13-1	○△	
825A	小ねじ JCIS ⊕ PM 2.0 x 2.5 Type (3) Screw	1		13 13-1	○	
830	小ねじ JCIS ⊕ PM 1.4 x 2.0 Type (3) Screw	2		8 8-1	○	
831	小ねじ JCIS ⊕ CM 1.4 x 4 Type (1) Screw	1	K	2	○△	
831-6	スイッチ制限Gリング Switch stopper G-ring	1	K-6	2-1	○△	
832	巻上レバービス (タップタイトネジ) ⊕ PM 2 x 4.5 Screw	2	P3-1	1 1-1	○△	
833-1	ゆるみ止めビス Set screw	1		4 4-1	○	
835	下地板ビスB ⊕ PM 2.0 x 3.5 Screw	3		3 3-1	○	
840	小ねじ JCIS ⊕ CM 2.0 x 3.0 Type (3) Screw	2		12 12-1	○	32FB #840
841	リリース軸用Eリング Release shaft E-ring	1		12 12-1	○	31F3B #836

部品表 Parts List

P33FB-R-3001-A

部品番号 Part No.	名 称 Name	1 台 個数 Per. per Unit	部組品No. Sub- assembly No.	参照図番 Reference Fig. No.	販売区 区分 Term of Sale	備 考 Remarks
842A	調整座金 (2.1 × 3.8 × 0.05) Washer		B-2 B-6	8 8-1	○△	
842B	調整座金 (2.1 × 3.8 × 0.06) Washer		B-2 B-6	8 8-1	○△	
842C	調整座金 (2.1 × 3.8 × 0.07) Washer		B-2 B-6	8 8-1	○△	
842D	調整座金 (2.1 × 3.8 × 0.08) Washer		B-2 B-6	8 8-1	○△	
842E	調整座金 (2.1 × 3.8 × 0.09) Washer		B-2 B-6	8 8-1	○△	
842F	調整座金 (2.1 × 3.8 × 0.1) Washer		B-2 B-6	8 8-1	○△	
842G	調整座金 (2.1 × 3.8 × 0.11) Washer		B-2 B-6	8 8-1	○△	
842H	調整座金 (2.1 × 3.8 × 0.12) Washer		B-2 B-6	8 8-1	○△	
842I	調整座金 (2.1 × 3.8 × 0.2) Washer		B-2 B-6	8 8-1	○△	
842J	調整座金 (2.1 × 3.8 × 0.3) Washer		B-2 B-6	8 8-1	○△	
842K-5	調整座金 (2.1 × 3.8 × 0.4) Washer		B-5	13-1 8-1	○△	
842M	調整座金 (2.1 × 3.8 × 0.5) Washer		B-1 B-5	10 10-1	○△	
842N	調整座金 (2.1 × 3.8 × 0.6) Washer		B-1 B-5	8 8-1	○△	
842P	調整座金 (2.1 × 3.8 × 0.7) Washer		B-1 B-5	8 8-1	○△	

部品表 Parts List

P33FB-R-3001-A

部品番号 Part No.	名 称 Name	1 台 個数 Pcs. per Unit	部組品No. Sub- assembly No.	参照図番 Reference Fig. No.	販売 区分 Term of Sale	備 考 Remarks
842Q	調整座金 (2.1 × 3.8 × 0.8) Washer		B-1 B-5	8 8-1	○△	
842R	調整座金 (2.1 × 3.8 × 0.9) Washer		B-1 B-5	8 8-1	○△	
842S	調整座金 (2.1 × 3.8 × 1.0) Washer		B-1 B-5	8 8-1	○△	
842T	調整座金 (2.1 × 3.8 × 1.1) Washer		B-1 B-5	8 8-1	○△	
842U	調整座金 (2.1 × 3.8 × 1.2) Washer		B-1 B-5	8 8-1	○△	
842V	調整座金 (2.1 × 3.8 × 0.03) Washer		B-1 B-5	8 8-1	○△	
843-5	スプロケットばね受座金 Washer	2		4 4-1	○	32FB #843
844-5	小ねじ JCIS ⊕ CM 2.0 x 5.0 Type (3) Screw	1	K-6	2-1	○△	
845-5	小ねじ JCIS ⊕ CM 2.0 x 3.0 Type (1) Screw	9		13, 13-1 2-1, 5-1 8, 8-1	○	
845A-5	小ねじ JCIS ⊕ PM 1.7 x 3.0 Type (1) Screw	1		2-1	○	
848	吊環ビス Eyelet set screw	2		12	○	32FB #848
848-1	スプリングピン (1.6 × 7) Spring pin	2		12-1	○	
850-1	エアーダンパーピストンピン Air damper piston pin	1	B-2	10	○△	
855A	小ねじ JCIS ⊕ CM 2.0 x 4.5 Type (3) Screw	2		12 12-1	○	

部組品一覧表 Subassembly list

P33FB-R-3001-A

部組品番号 No. of Sub- assembly	名 称 Name	1 台 個 数 Pcs. per Unit	構 成 部 品 番 号 No. of Constituent Parts	参 照 図 番 Reference Fig. No.	備 考 Remarks
A2	耳 環 Eyelet	2	11, 12	12	
A2-1	耳 環 Eyelet	2	11-1, 12	12-1	
A4	シャッターチャージレバー Shutter charge lever	1	24, 32, 33, 35, 37-1, 38x2	4	
A4A(03)	シャッターチャージレバー Shutter charge lever	1	24, 32, 33, 35, 37-1, 38x2	4	特寸 -0.15
A4A(04)	シャッターチャージレバー Shutter charge lever	1	24, 32, 33, 35, 37-1, 38x2	4	特寸 +0.15
A4-1	シャッターチャージレバー Shutter charge lever	1	32-1, 24, 33-1, 35, 37-1, 38-1	4-1	
A5-2	電池ケース Battery chamber	1	43-2, 47, 48, 49, 906-2 907-2	12 12-1	
A6-5	チャージレバー Charge lever	1	21-5, 22, 23-5, 24	12 12-1	
A7-1	スプール上ギア Spool upper gear	1	420-1, 421, 424-1, 456-1, 456A 456B-1, 497x16, 824x3	4 4-1	
A8	スプール Spool	1	528, 455, 455A	4 4-1	
A9	スプール軸 Spool shaft	1	453, 456C, 529	4 4-1	
A10A-1	セットカムA Set cam A	1	459-1, 458, 461, 530A	4	
A10B-2	セットカムB Set cam B	1	459-1, 458, 461, 530B-1	4-1	

部組品一覧表 Subassembly list

P33FB-R-3001-A

部組品番号 No. of Sub- assembly	名 称 Name	1 台 個数 Pcs. per Unit	構 成 部 品 番 号 No. of Constituent Parts	参照図番 Reference Fig. No.	備 考 Remarks
A11	下地板 Lower base plate	1	416-1, 417-2, 418, 419 422, 423, 425, 426x3, 427 440, 443, 444, 445, 446A-5 448, 450, 452, 457, 516-1 517, 534, 540Ax2, 819x2 A12	3	
A11-6	下地板 Lower base plate	1	452-6, 416-1, 417-6, 418 419, 422-6, 423, 425 426x3, 427, 440, 443, 444 445, 446A-5, 448, 450, 457 496-6, 497x24, 888 A12-6	3-1	
A12	スプロストッパー Sprocket stopper	1	447, 449	3	
A12-6	スプロストッパー Sprocket stopper	1	447-6, 449	3-1	
A13-6	面カム Clutch cam	1	414-6, 414A-5	3-1	
A14	スプール軸受ケース Spool shaft bearing cause	1	454, 423, 457, 497x8	4 4-1	
A17-1	MD外部接点 MD electrical contact	1	916-1, 919-1x4, 924-1	4 4-1	
A18	巻上ギア Wind-up gear		412x3, 412Bx6, 414x3, 415	3	
B1 ⁽⁰¹⁾ B1 ⁽⁰²⁾	セルフレバー Self-timer lever	1	16, 16A	8	
B10	絞りレバー Diaphragm actuating lever	1	315, 312, 316	9 9-1	
B11-6	大レバー Mirror charge lever	1	333-6, 335-5	11-1	
B13-6	ミラーダウンレバー Mirror-down lever	1	323-6, 325-1, 350-5, 358-6 372	9-1	

部 品 表 Parts List

P33FB-R-3001-A

部品番号 Part No.	名 称 Name	1 台 個 数 Pcs. per Unit	部組品No. Sub- assembly No.	参照図番 Reference Fig. No.	販 売 区 分 Term of Sale	備 考 Remarks
857-5	大レバー座金 Washer	1	B-5	12 12-1	○	
.863-5	M. BOX下基板ビス Screw	3	B-6	11-1	○△	
871	振り子偏心軸ビス Eccentric screw	1		13 13-1	○	
875	止めねじUS 1.4 × 2.5 Set screw	2	N1	8, 8-1	○△	
879	リリースレバーガイド軸 Release lever guide pin	1		12, 12-1	○	
882	小ねじ JCIS ⊕ CM 1.7 x 3.0 Type (1) Screw	2		15-1	○	32FB #882
883	Rボタン用Eリング Rewind button E-ring	1	D-1	13 13-1	○△	32FB #883
887	スプロケット左ねじ Sprocket screw (left handed)	1		4 4-1	○	
888	スプロSTOPパービス Sprocket stopper screw	1	A11 A11-6	3 3-1	○△	
889	三角環 Neck-strap ring	2		12, 12-1	○	S-8219
890-1	三角環保護カバー Neck-strap ring cover	2		12 12-1	○	
893	絞り運動片バネビス Aperture coupling piece screw	2	B-2	7	○△	32FB1 #893 (~8)
897A	巻上ギアワッシャー Washer (6.5 x 9.5 x 0.05)	1		3 3-1	○	
897B	巻上ギアワッシャー Washer (6.5 x 9.5 x 0.1)	1		3 3-1	○	

部 品 表 Parts List

P33FB-R-3001-A

部品番号 Part No.	名 称 Name	1 台 個 数 Pcs. per Unit	部組品No. Sub- assembly No.	参照図番 Reference Fig. No.	販 売 区 分 Term of Sale	備 考 Remarks
897C	巻上ギアワッシャー (6.5×9.5×0.2) Washer	1		3 3-1	○	
897D	巻上ギアワッシャー (6.5×9.5×0.3) Washer	1		3-1	○	
897E	巻上ギアワッシャー (6.5×9.5×0.25) Washer	1		3-1	○	
897F	巻上ギアワッシャー (6.5×9.5×0.15) Washer	1		3-1	○	
906-2	MD巻上スイッチA MD take-up switch A	1	A5-2		△	
907-2	MD巻上スイッチB MD take-up switch B	1	A5-2		△	
910	MD軸受 MD shaft bearing	1		13 13-1	○	
911	MD軸 MD shaft	1		13 13-1	○	
912	MDシーソーレバー MD see-saw lever	1		13 13-1	○	
913	リリース連結ねじ Release shaft connecting screw	1		13 13-1	○	
914	MDシーソーレバー軸 See-saw lever axle	1		13 13-1	○	
915	小ねじ JCIS ⊕ CM 2.0 x 4.5 Type (1) Screw	1		13-1	○	
916-1	MD外部接点受け MD electrical contact socket	1	A17-1		△	
919-1	外部接点ラグ板 MD external contact lug	4	A17-1		△	

部組品一覧表 Subassembly list

P33FB-R.3001-A

部組品番号 No. of Sub- assembly	名 称 Name	1 台 個数 Pcs. per Unit	構成部品番号 No. of Constituent Parts	参照図番 Reference Fig. No.	備 考 Remarks
B14	ミラーダウン信号レバー Mirror-down signal lever	1	288-1, 289-1	9 9-1	
B20	エアダンパー Air damper	1	385-1, 386-2, 387, 388, 392 393-3, 397, 397-1, 850-1, 856	10	
B20-1	エアダンパー Air damper	1	388, 386-3, 387, 392, 393-3, 397-1	10-1	
B33-2	絞りレバーばね掛け Diaphragm spring stub	1	376-1, 324-1	9 9-1	
B27-6	手動絞りレバー Manual stop-down lever	1	310-1, 311-6	9-1	
B38-5	ミラーボックス後部遮光板 Mirror box rear light-tight plate	1	86-5, 83-5	9-1	
C4	接眼密 Eyepiece ring	1	8-1, 8A, 9, G7	1 1-1	
C7	接点モールド Contact mold	1	71-1, 70-1	1-1	
D-1(01)	底 蓋 Bottom plate	1	4, 439, 540, 883, 922 A4	13 13-1	
D-1(02)	底 蓋 Bottom plate	1	4, 439, 540, 883, 922	13 13-1	
E1	裏 蓋 Camera back	1	701-1, 705x4, 707, 710 711x2, 712x3, 715, 716 717x2, 718, 719, 720 721x7, 722, 723-1, 725 726, 727, 728, 730x2, 731 732	14-1	
E2	圧 板 Pressure plate	1	702-2, 703, 704-2x2	14-1	
KS	送り爪レバー Advance lever	1	510-1, 511-1, 513-1, 515-1	2 2-1	

部組品一覧表 Subassembly list

P33FB-R-3001-A

部組品番号 No. of Sub- assembly	名 称 Name	1 台 個数 Pcs. per Unit	構成部品番号 No. of Constituent Parts	参照図番 Reference Fig. No.	備 考 Remarks
K6	零戻しレバー Counter release lever	1	522, 524	2	
P5	電池キャップ Battery chamber cap	1	44, 46	13 13-1	

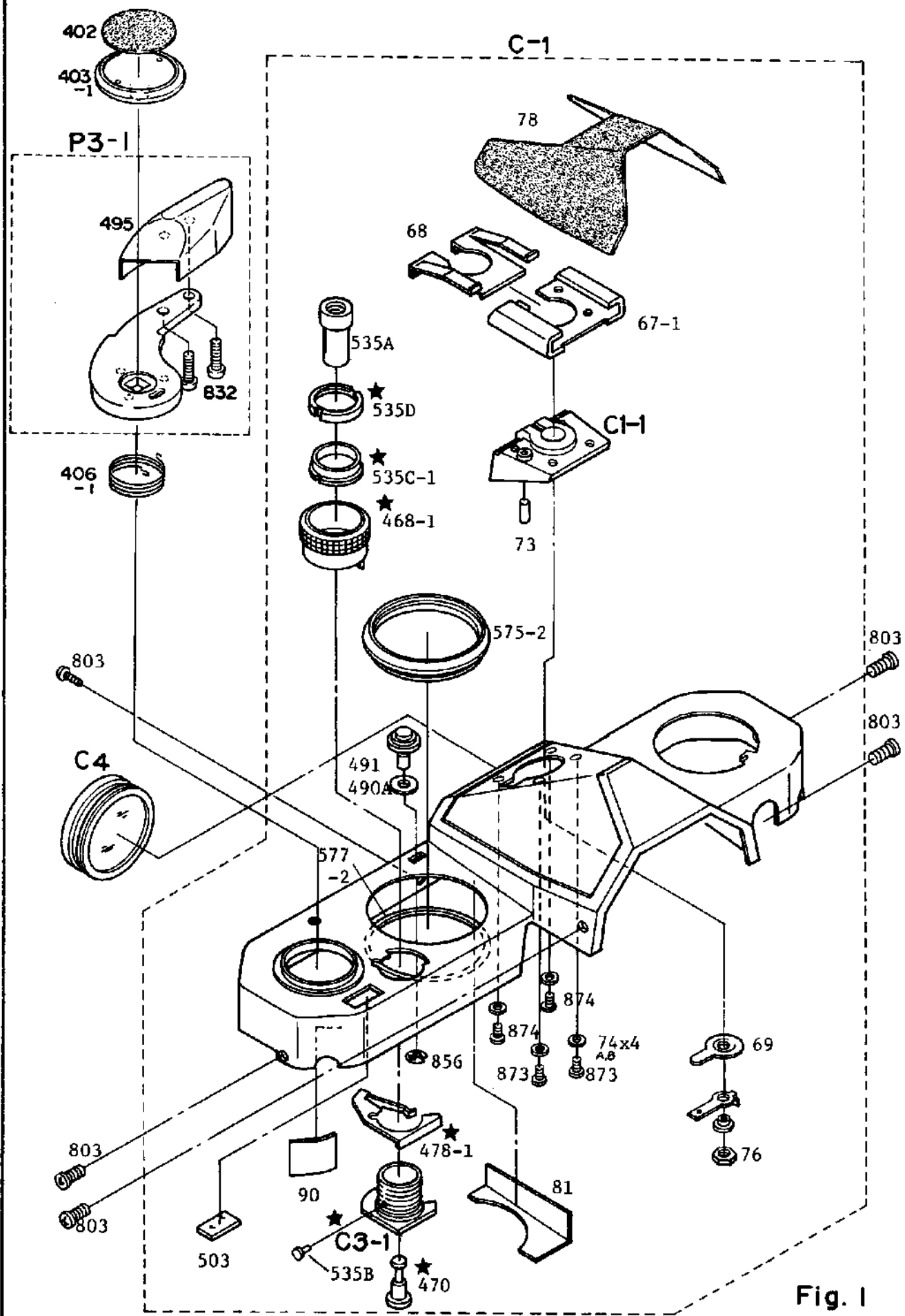


Fig. 1

NEW

C - 6

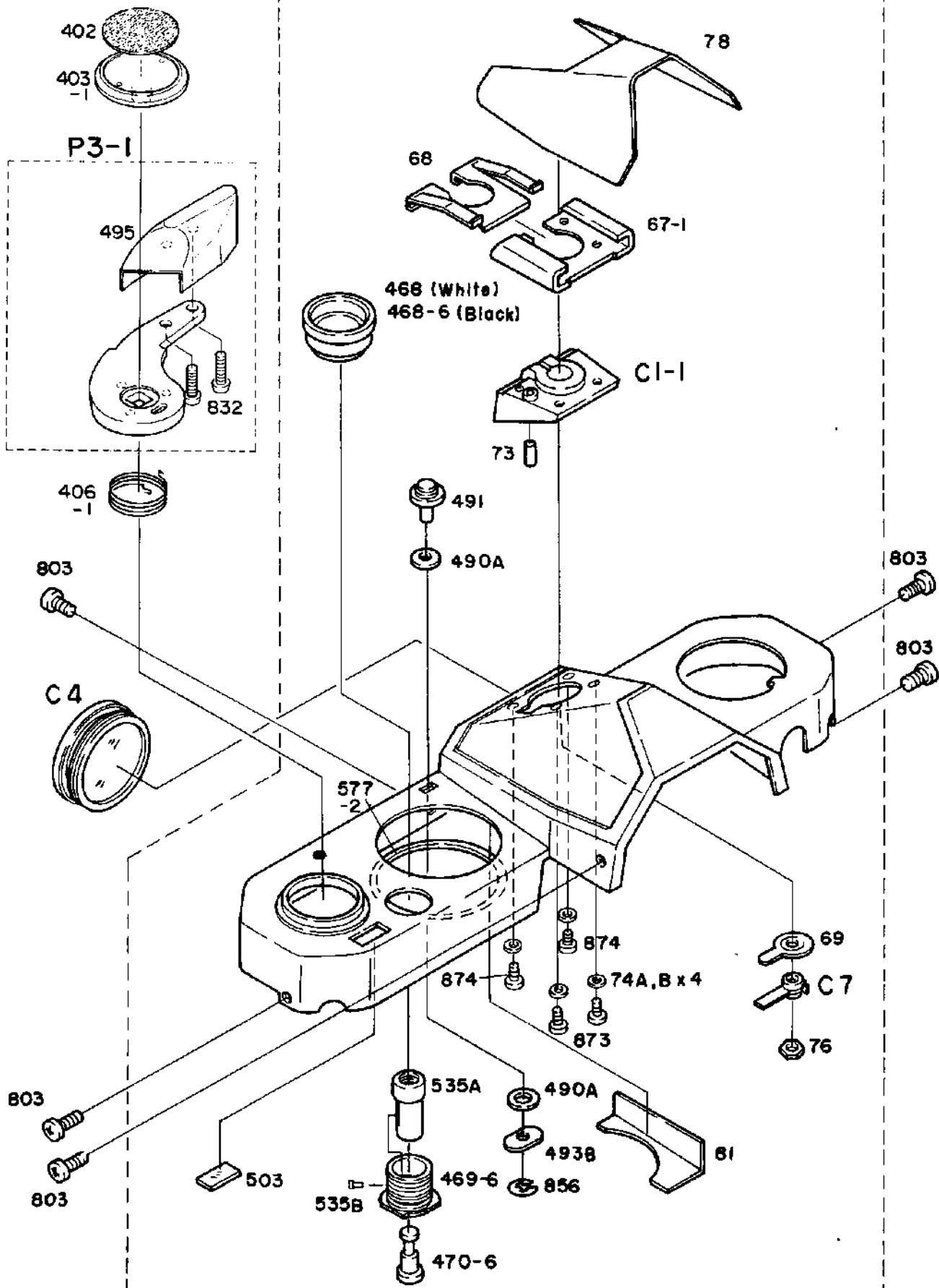


Fig. 1-1

部品番号 Part No.	名称 Name	備考 Remarks	部品番号 Part No.	名称 Name	備考 Remarks
33FB 67-1	ホットシュー Hot-shoe contact		856	多重ツマミ用Eリング E-ring	
68 (01)(02)	シューばね Shoe contact		873	シュービス (短) JCIS ⊕ PM 1.7x5 Type (3) Screw	
76	シンクロ接点ナット Sync. socket nut		874	シュービス (長) JCIS ⊕ PM 1.7x8.2 Type (3) Screw	
78	ペンタ革 Penta-prism cover leatherette				
81	FRE シート絶縁 FRE insulator		★ C-1 (01)(02)	上蓋 Top cover	
★ 90	MD スイッチ絶縁テープ MD switch insulator tape		C-6 (01)(02)	上蓋 Top cover	
406-1	レバー戻しばね Film-advance lever retaining spring		C1-1	シュー座モールド Shoe mount mold	
★ 468-1 (01)(02)	リリース釦飾り環 Release button ring		★ C3-1	かぶせリリース環 Release button cover ring	
468-6	リリース釦飾り環 Release button ring		P3-1 (01)(02)	巻上レバー Wind-up lever	
★ 470	リリース内筒 Release inner tube				
470-6	リリース内筒 Release inner tube				
★ 478-1	クリックレバー Click lever		P33FB		
490A	多重ツマミ保護シート Multi-exposure knob washer		P33FB 69	押え接点 Upper shoe switch contact	
491 (01)(02)	多重振りツマミ Multi-exposure knob		74A,B	シュー座金 Shoe washer	
493B	多重ツマミ遮光板 Multi-exposure knob light baffle		402	巻上レバー用皮 Wind-up lever leatherette	
503	枚数計窓 Counter window		403-1 (01)(02)	レバー押えねじ Wind-up lever screw	
★ 535C-1	リリース釦下ナット Release button nut		469-6	かぶせリリース環 Release ring	
★ 535D	リリース釦上ナット Release button nut		495	指あて Wind-up lever knob	
575-2 (01)(02)	飾り環 Cover ring		535A	リリース釦 Release button	
577-2	飾り環座金 Washer		535B	リリースガイドビス Release guide screw	

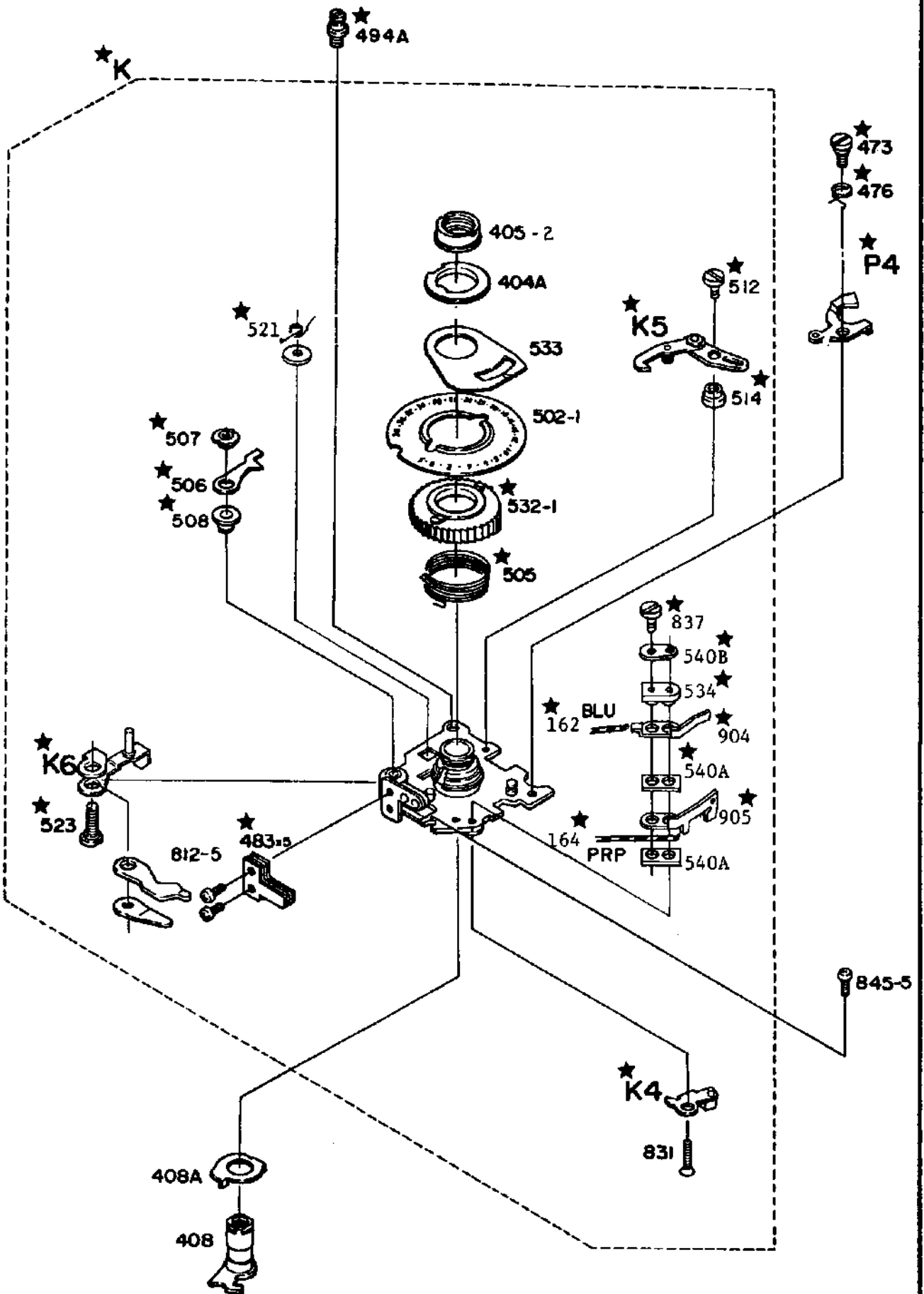


Fig. 2

NEW

K - 6

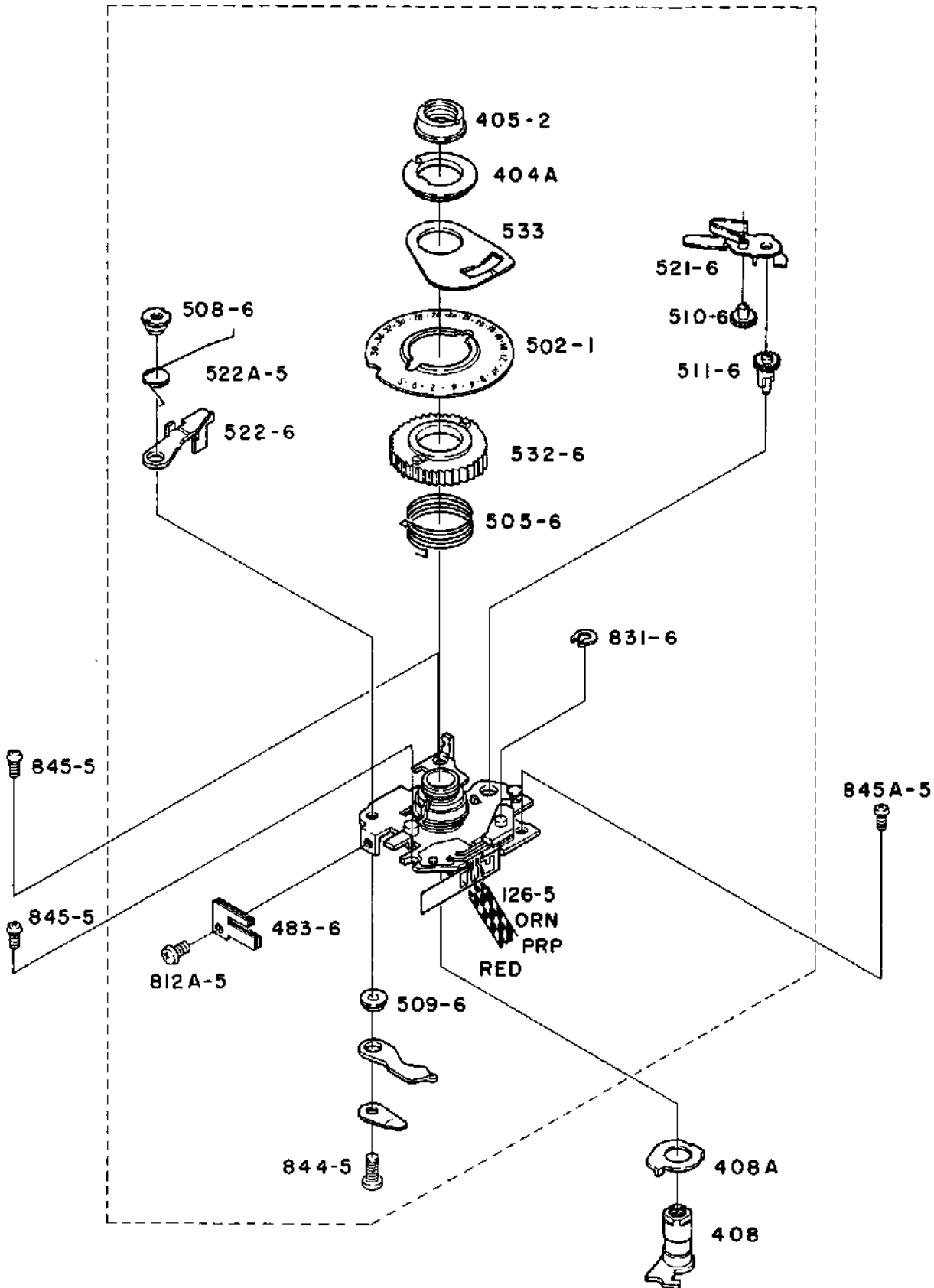


Fig. 2-1

部品番号 Part No.	名称 Name	備考 Remarks	部品番号 Part No.	名称 Name	備考 Remarks
33FB ★162	MDスイッチリード線 Lead wire, MD switch		P33FB 408A	スプロ制限除板 Sprocket stopper release plate	
★164	後幕シグナルリード線 Lead wire, rear curtain signal		★473	スイッチ制限軸 Switch stopper axle	
404A	枚数計押え板 Counter retaining plate		★483	クリックレバーバネ Click lever spring	
★476	スイッチ制限バネ Switch stopper spring		483-6	クリックレバーバネ Click lever spring	
★494A	多重アーム戻しバネ掛り Spring stud		502-1	枚数計 Frame-counter dial	
★540B	MDスイッチ座金 MD Switch base plate		★505	カウンターバネ Counter spring	
★837	ダイヤルプーリ取付ビス Screw		505-6	カウンターバネ Counter spring	
★904	MDスイッチ接片A MD Switch contact A		★506	止爪 Ratchet claw	
★905	MDスイッチ接片B MD Switch contact B		★507	止爪ナット Ratchet claw nut	
			★508	止爪カラー Ratchet claw collar	
★K	上地板 Upper-bracket		508-6	零戻しレバーナット Counter reverse lever nut	
★K-6	上地板 Upper-bracket		509-6	クリックレバーカラー Click lever collar	
★K4	スイッチレバー MD Switch lever		510-6	送り爪ギア Advance claw gear	
★P4	スイッチ制限 MD Switch stopper		511-6	カウンタ連動ギア Counter gear	
			★512	送り爪レバー軸 Advance claw lever axle	
			★514	送り爪レバー軸カラー Advance claw lever axle collar	
P33FB			★521	零戻しバネ Resetting spring	
P33FB 126-5	上地スイッチコード Switch cord		521-6	送り爪バネ Claw spring	
405-2	レバー軸ナット Lever		522-6	零戻しレバー Counter reset lever	
408	巻上軸 Film-advance shaft		522A-5	零戻しレバーバネ Counter reset lever spring	

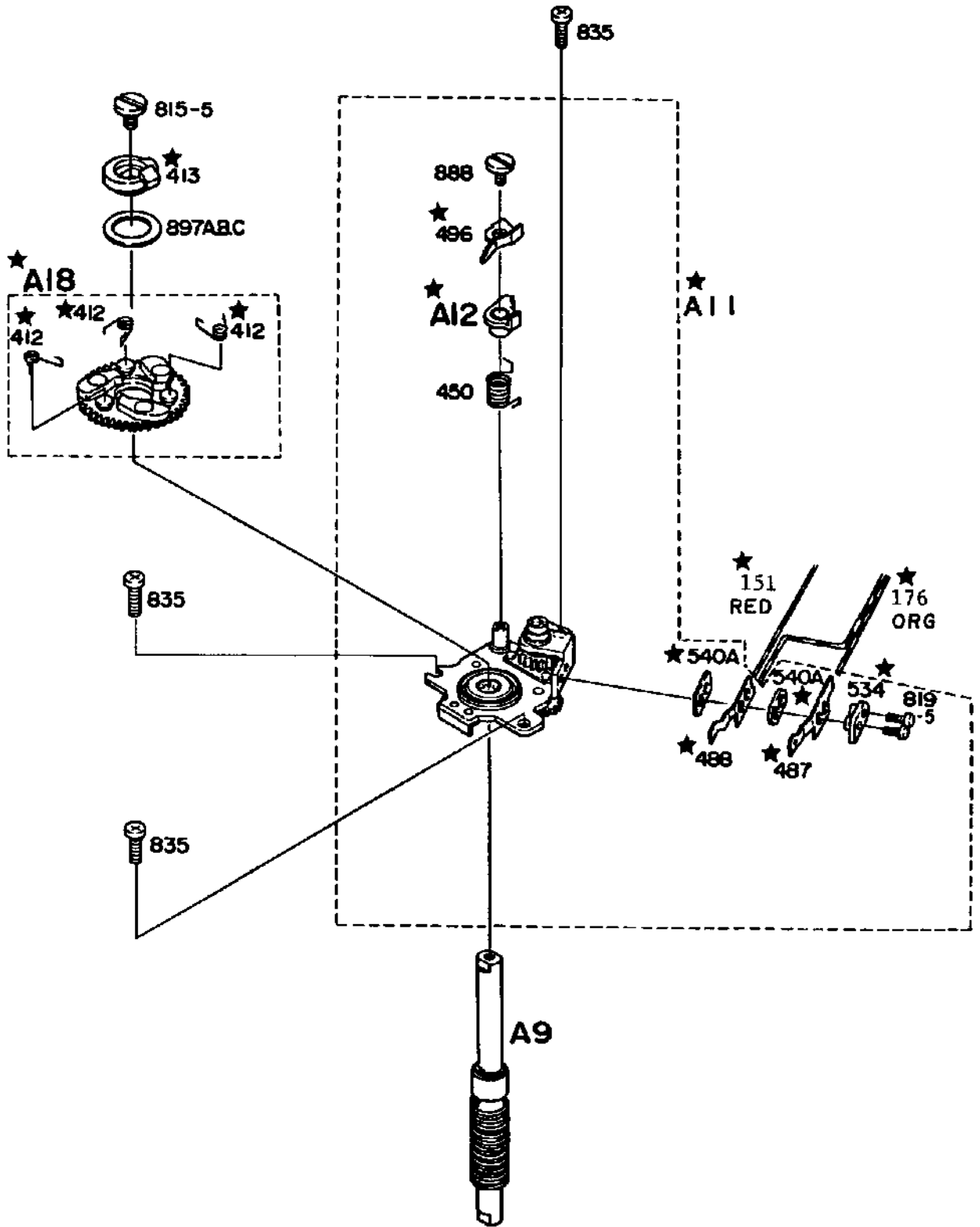


Fig. 3

NEW

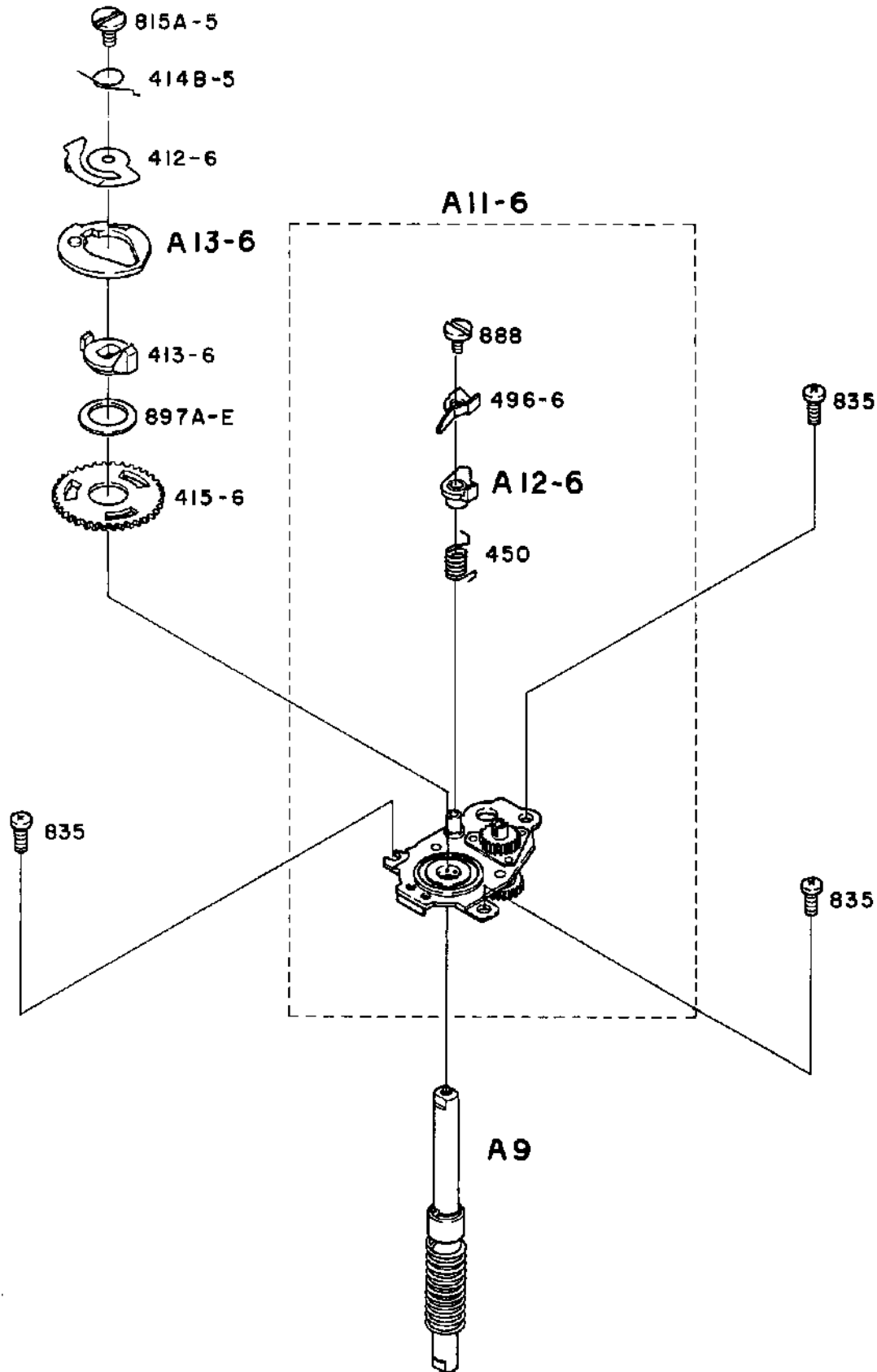


Fig. 3-1

部品番号 Part No.	名称 Name	備考 Remarks	部品番号 Part No.	名称 Name	備考 Remarks
33FB ★ 151	レバースイッチリード線B Lead wire, lever SW, B		835	下地板ビスB Screw	
★ 176	レバースイッチリード線A Lead wire, lever SW, A		888	スプロストッパービス Sprocket stopper screw	
819-5	小ネジ JCIS ⊕ PM 1.4x3 Type (3) Screw		897 A ~ F	巻上ギアワッシャー Washer	
P33FB			A9	スプール軸 Spool shaft	
P33FB ★ 412	三羽根爪押えバネ Charge cam claw retaining spring		★ A11	下地板 Lower base plate	
412-6	面カム板バネ Clutch cam spring		A11-6	下地板 Lower base plate	
★ 413	巻上げカム Film advance cam		★ A12	スプロストッパー Sprocket stopper	
413-6	巻上げカム Film advance cam		A12-6	スプロストッパー Sprocket stopper	
414B-5	面カムねじりバネ Clutch spring		A13-6	面カム Clutch cam	
415-6	巻上ギア Advance gear		★ A18	巻上ギア Wind-up gear	
450	スプロストッパー戻しバネ Sprocket stopper returning spring				
★ 487	主スイッチ切片A Lever switch contact A				
★ 488	主スイッチ切片B Lever switch contact B				
★ 496	スプロ制限板バネ Sprocket stopper spring				
496-6	スプロ制限板バネ Sprocket stopper spring				
★ 534	スイッチ押え板 MD Switch cover				
★ 540A	MDスイッチ絶縁板 MD Switch insulation plate				
★ 815-5	巻上軸ビス (左ネジ) Film-advance shaft screw (Left-handed)				
815A-5	巻上軸ビス Film-advance shaft				

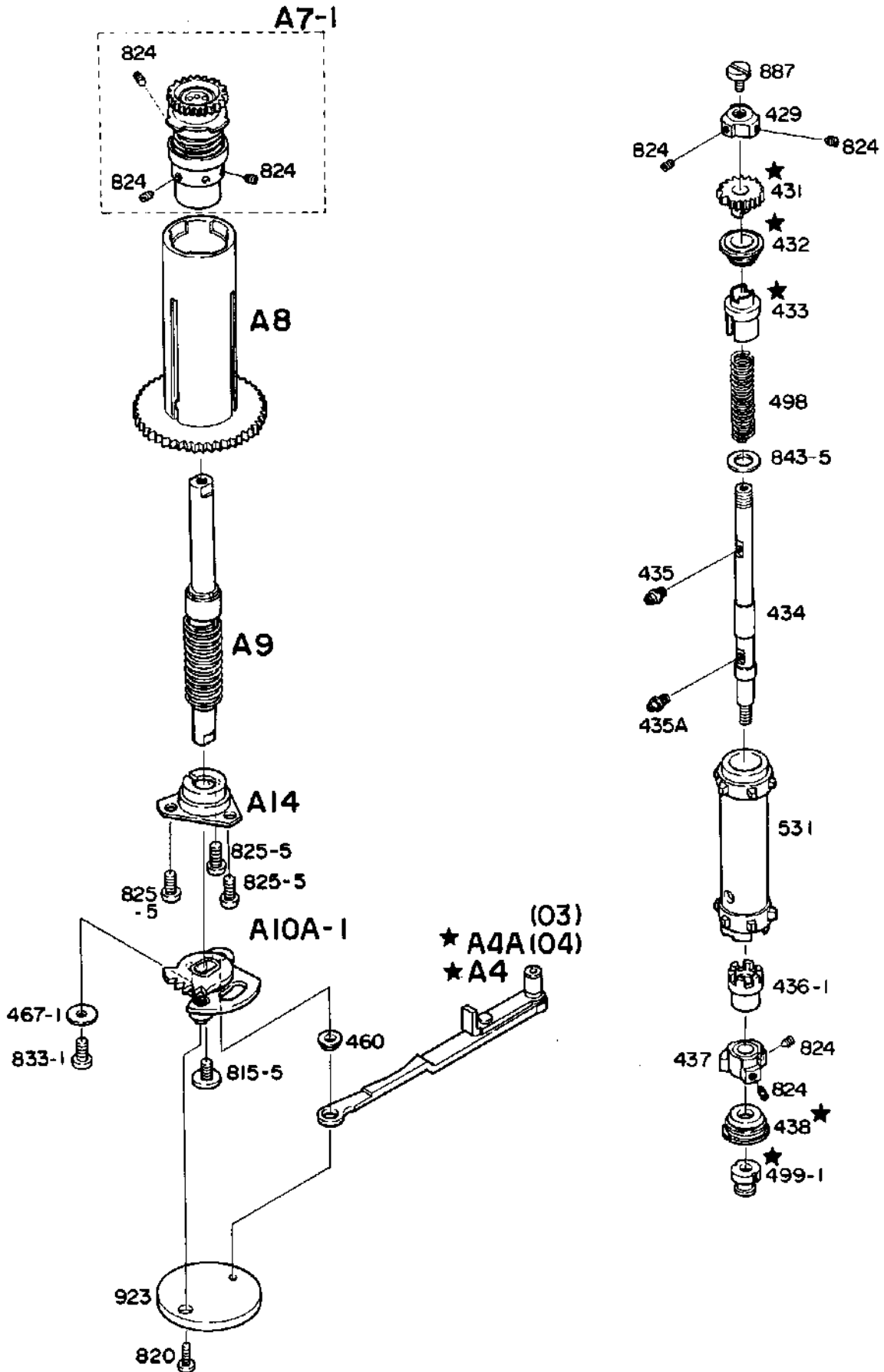


Fig. 4

NEW

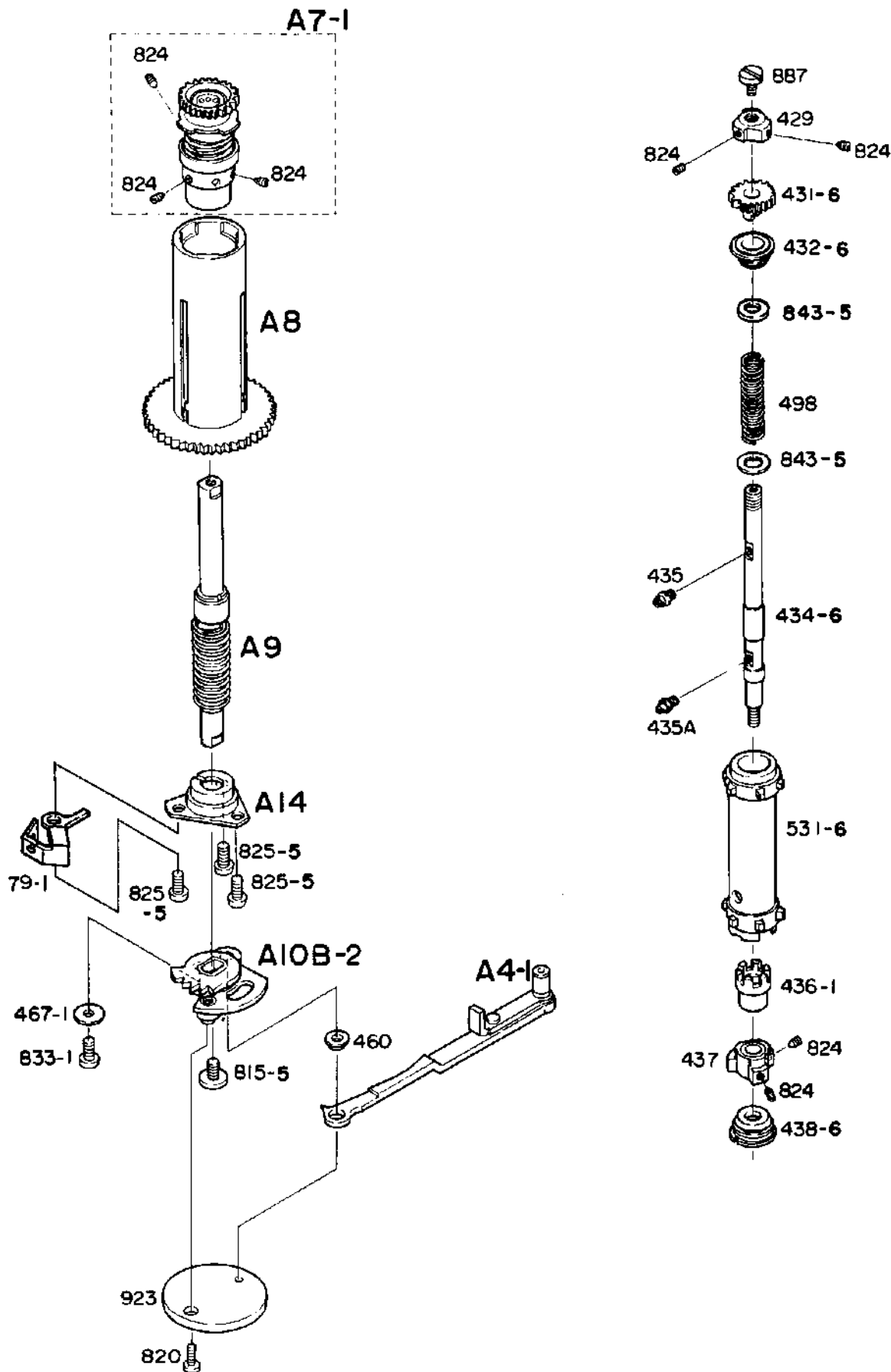


Fig. 4-1

部品番号 Part No.	名称 Name	備考 Remarks	部品番号 Part No.	名称 Name	備考 Remarks
33FB 79-1	緩衝板 Baffle plate		P33FB 531	スプロケット Sprocket	
P33FB			531-6	スプロケット Sprocket	
P33FB 429	スプロケット制限カム Sprocket stopper cam		815-5	巻上軸ビス (左ネジ) Film-advance shaft screw	
★ 431	スプロ上ギア Sprocket upper gear		815A-5	巻上軸ビス Film-advance shaft screw	
431-6	スプロ上ギア Sprocket upper gear		820	カップリングビス Coupling screw	
★ 432	スプロケット上軸受 Sprocket shaft bearing		824	ギアセットビス Gear set screw	
432-6	スプロケット上軸受 Sprocket shaft bearing		825-5	小ネジ JCIS Φ PM 2.0x2.5 Type (I) Screw	
★ 433	スプロケットカラー Sprocket collar		833-1	ゆるみ止めビス Set screw	
434	スプロケット軸 Sprocket shaft		843-5	スプロケットパネ受座金 Washer	
434-6	スプロケット軸 Sprocket shaft		887	スプロケット左ネジ Sprocket screw (Left handed)	
435	スプロケットビス Sprocket screw		923	モーターカップリング Motor coupling	
435A	スプロケットビスA Sprocket screw A		★ A4	シャッターチャージレバー Shutter charge lever	
436-1	スプロケットローラ-A Sprocket roller A		★ A4 (03)(04)	シャッターチャージレバー Shutter charge lever	
437	スプロカラーAナット Sprocket collar A nut		A4-1	シャッターチャージレバー Shutter charge lever	
★ 438	スプロ軸受 Sprocket shaft bearing		A7-1	スプールのギア Spool upper gear	
438-6	スプロ軸受 Sprocket shaft bearing		A8	スプール Spool	
460	セットカムカラー Set cam collar		A9	スプールの軸 Spool shaft	
467-1	ゆるみ止めカラー Collar		A10A-1	セットカムA Set cam A	
498	スプロケットパネ Sprocket spring		A10B-2	セットカムB Set cam B	
★ 499-1	スプロケット軸カラー Sprocket shaft collar		A14	スプールの軸受ケース Spool shaft bearing cause	

NEW

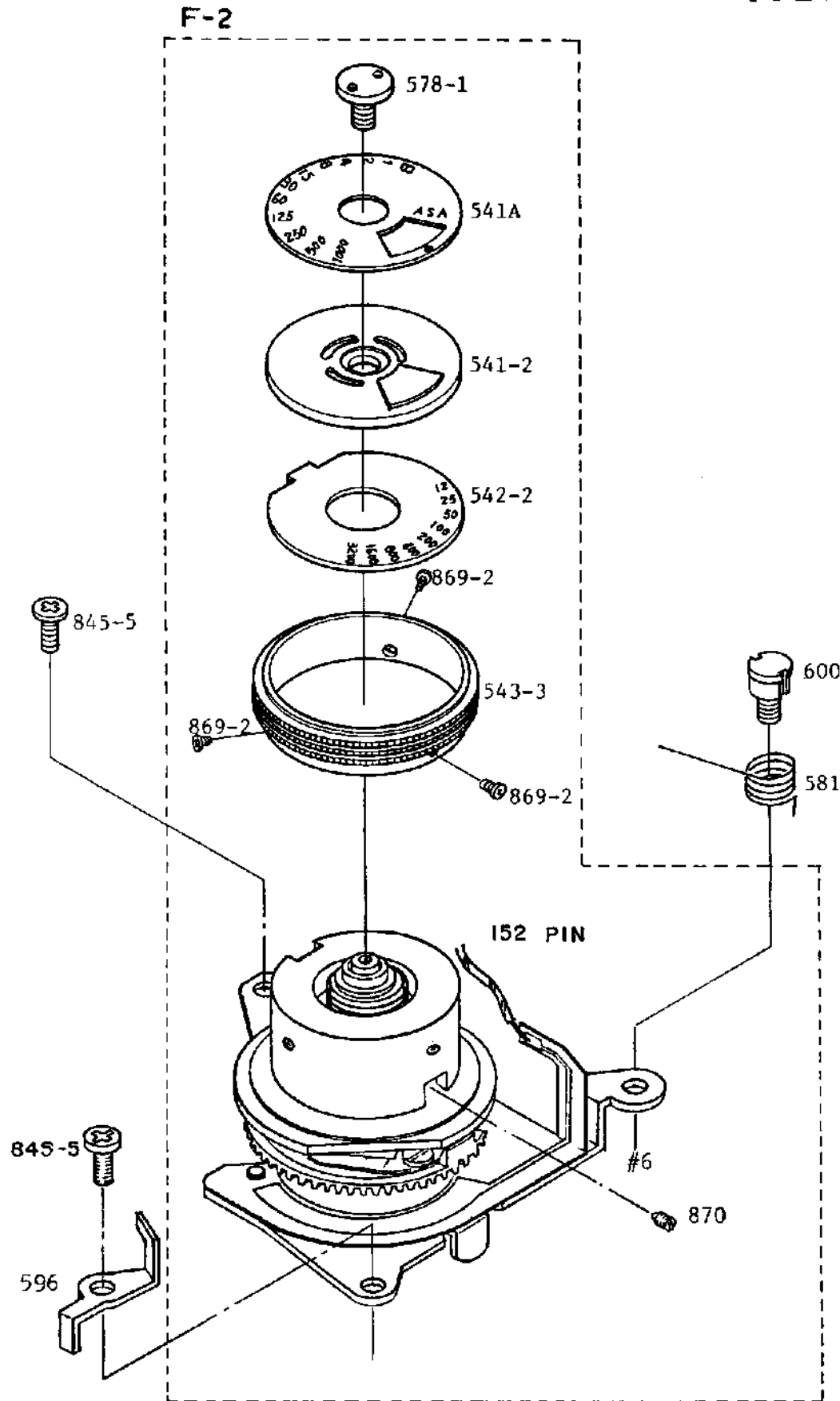


Fig. 5-1

NEW

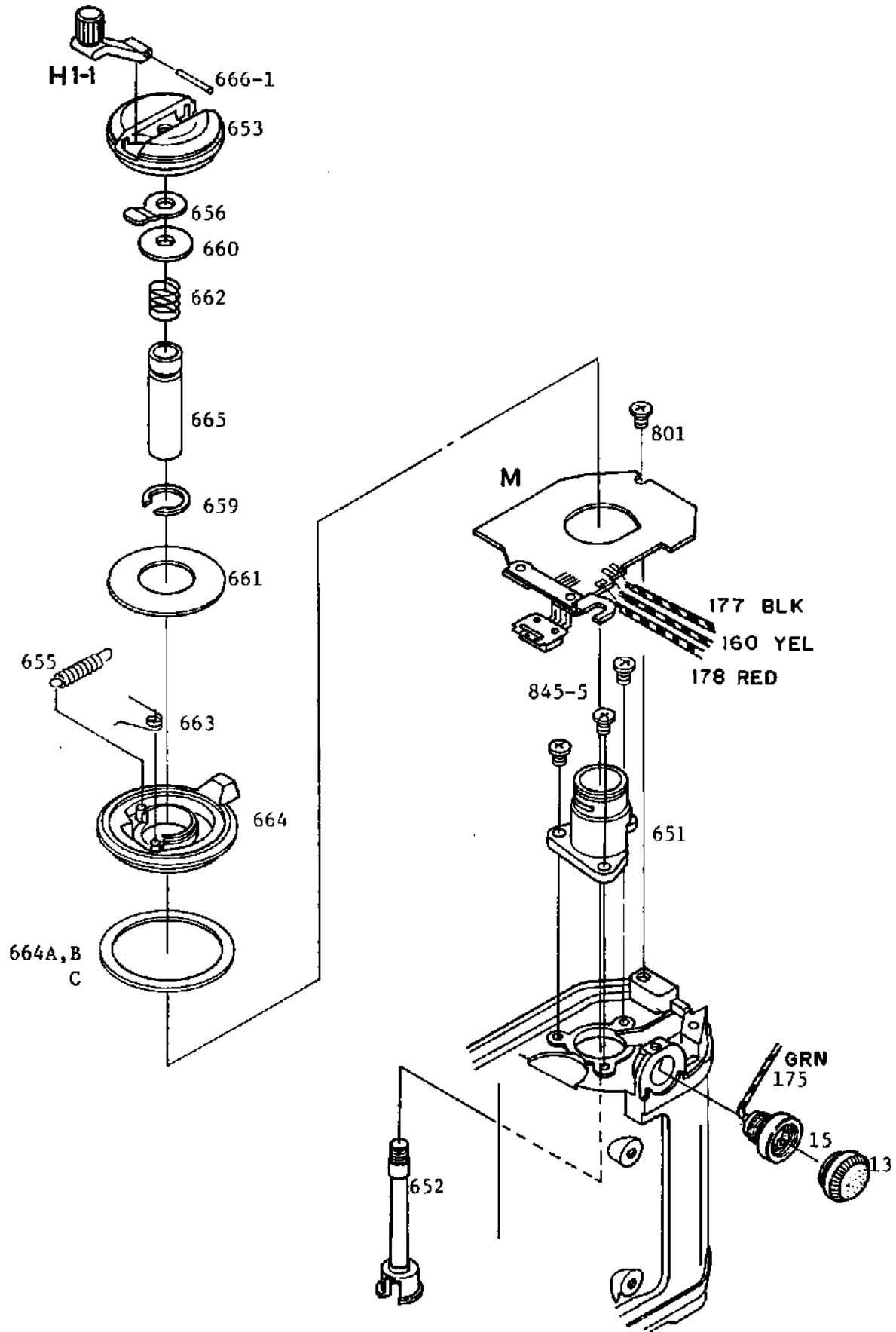


Fig. 6-1

部品番号 Part No.	名称 Name	備考 Remarks	部品番号 Part No.	名称 Name	備考 Remarks
33FB 175	シンクロリード線 Lead wire sync.		P33FB		
651	巻戻軸受 Rewind shaft bearing		P33FB 13	ターミナルキャップ Terminal cap	
652 (03)(04)	巻戻軸 Rewind shaft		15	シンクロソケット Synch. socket	
653	巻戻しノブ Rewind knob		656	レバー受バネ Rewind crank spring	
655	開閉ノブバネ Spring		666-1	巻戻しレバー軸 Rewind crank shaft	
659	開閉ノブ押えクリップ Knob clip		801	小ネジ JCIS ⊕ PM 2.0x3.0 Type (3) Screw	
660	巻戻軸座金 Washer		845-5	小ネジ JCIS ⊕ CM 2.0x3.0 Type (1) Screw	
661	巻戻し飾り板 Cover ring				
662	フリクションバネ Friction spring				
663	開閉ロックバネ Spring				
664 (01)(02)	開閉ノブ Back cover lock knob				
664 A~C	巻戻円座スペーサー Rewind ring spacer				
665	巻戻し軸ガイド Rewind shaft guide				
867	Sソケット止ネジ Set screw				
H1-1	巻戻しレバー Rewind lever				
M	ICプリント板 IC printed circuit				

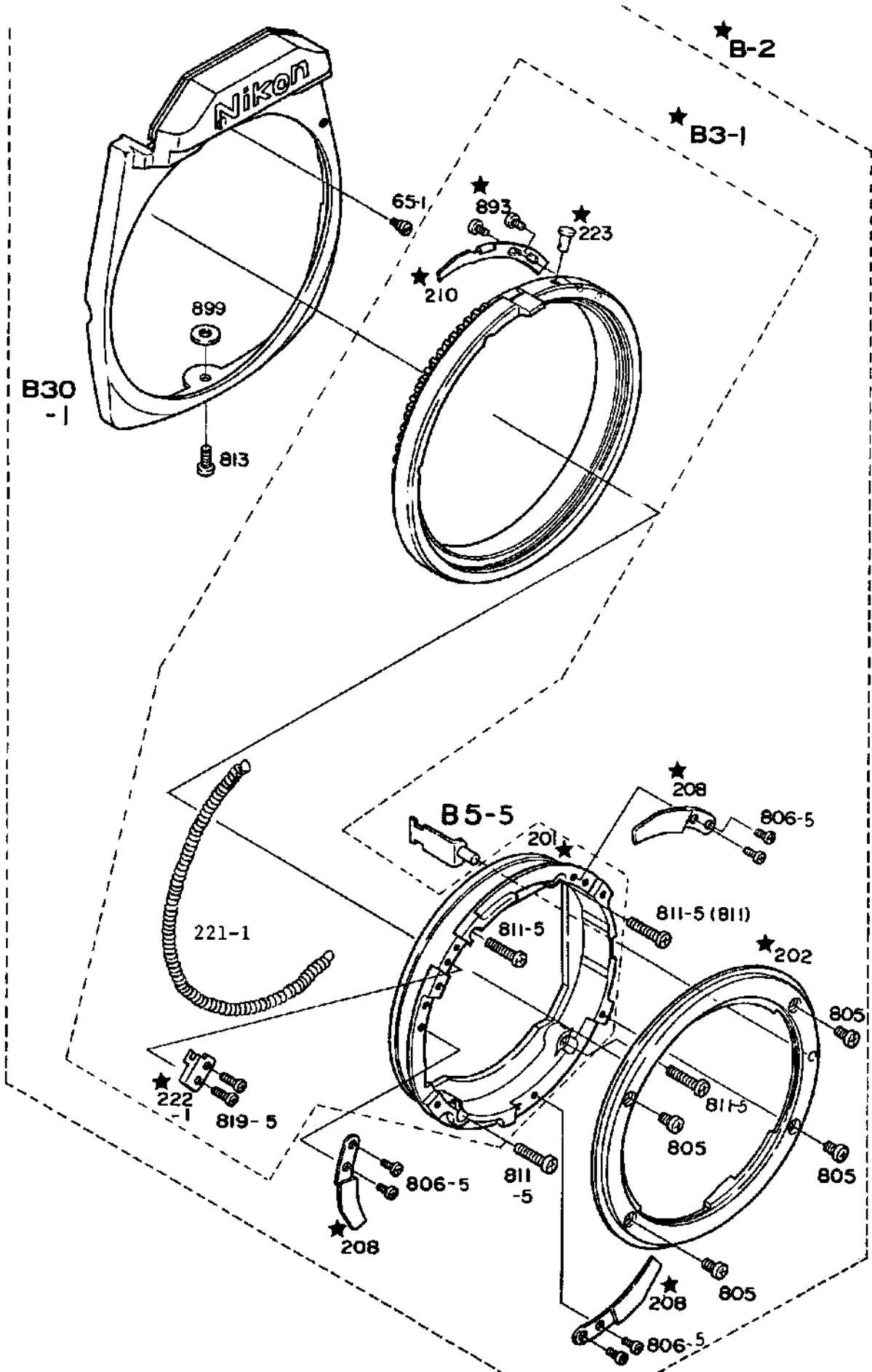


Fig. 7

NEW

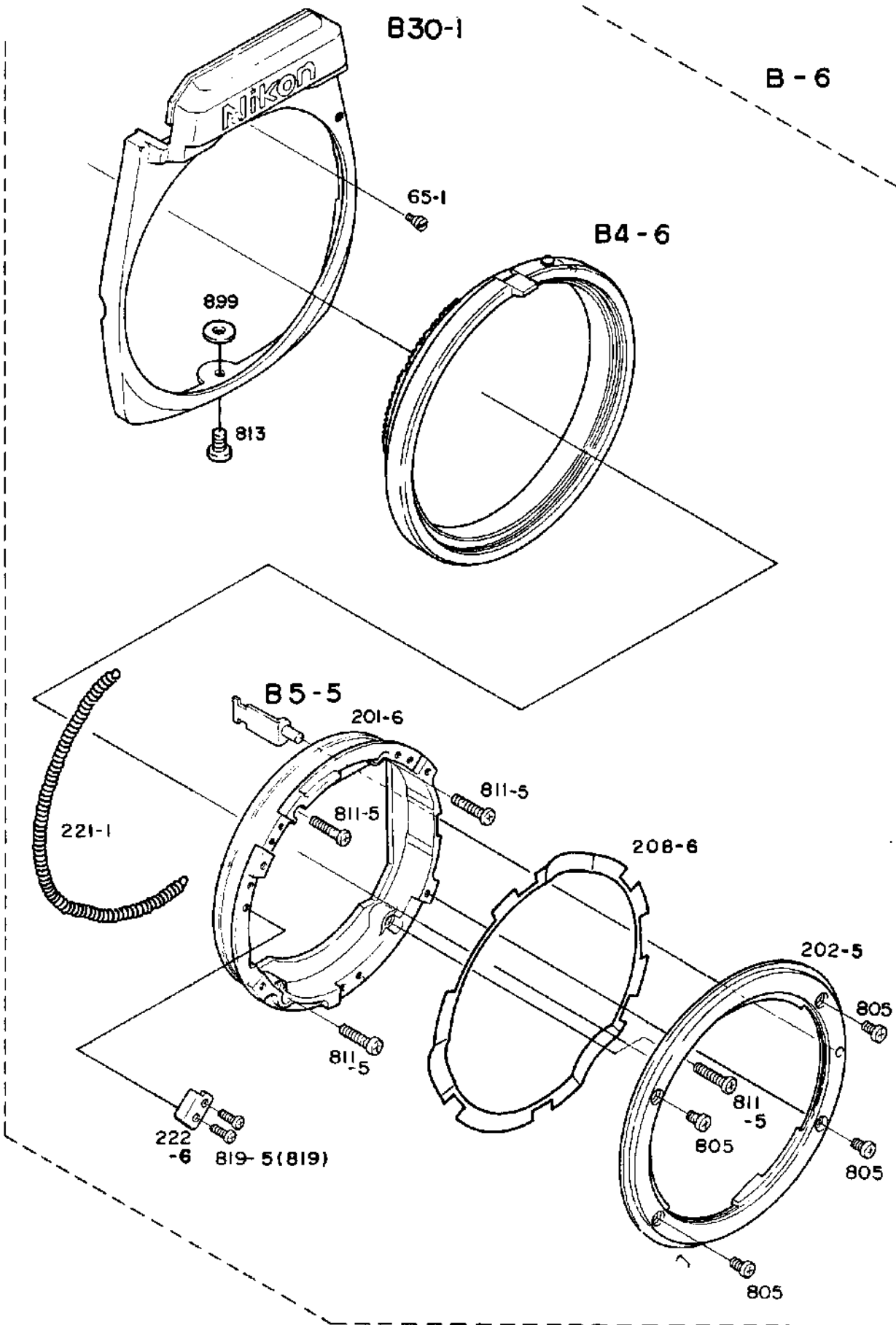


Fig.7-1

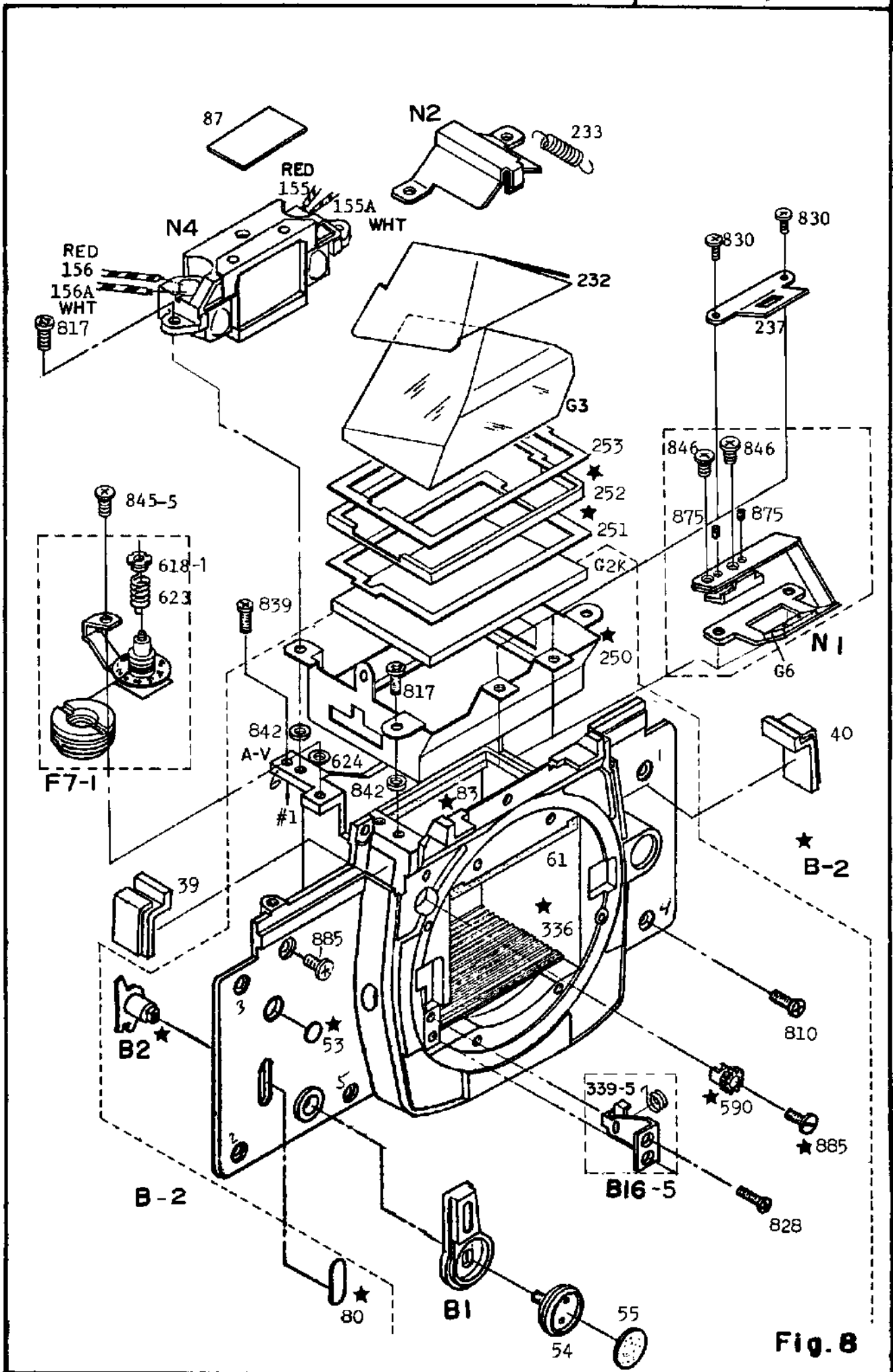


Fig. 8

NEW

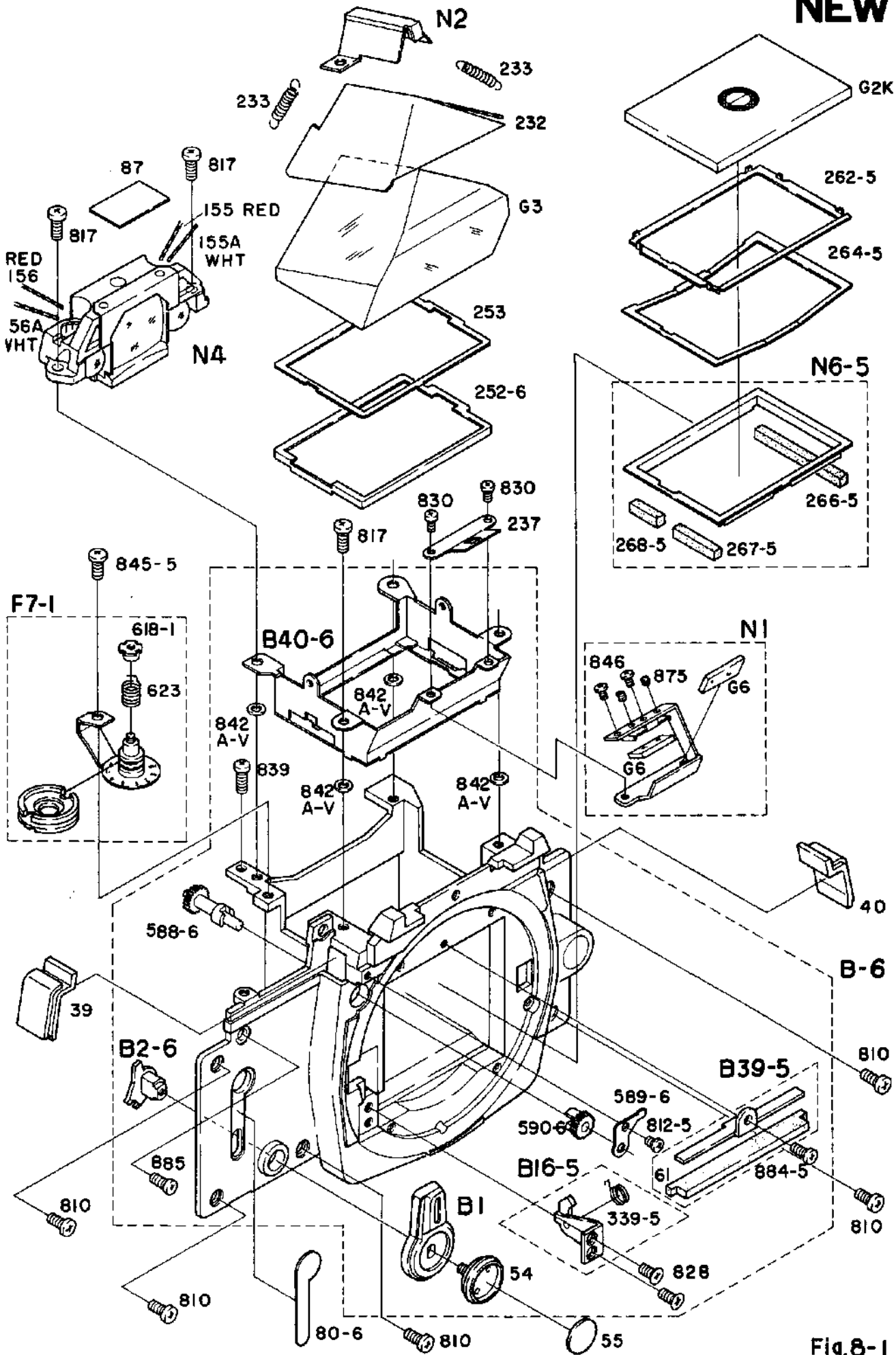


Fig.8-1

部品番号 Part No.	名称 Name	備考 Remarks	部品番号 Part No.	名称 Name	備考 Remarks
33FB 39	前板右肩カバー Shoulder cover, right		33FB 264-5	フレネルバネ Focusing screen spring	
40	前板左肩カバー Shoulder cover, Left		266-5	フレネルバネ受けモルトA Focusing screen frame sponge A	
61	ミラーアップ受けモルト Mirror-up cushion sponge		267-5	フレネルバネ受けモルトB Focusing screen frame sponge B	
★ 80	前板孔カバー B Front plate hole cover B		268-5	フレネルバネ受けモルトC Focusing screen frame sponge C	
80-6	前板孔カバー Front plate hole cover		★ 336	底遮光板 Bottom light baffle	
★ 83	ミラーボックス後部モルト Mirror box rear light-tight		588-6	軸付ギア Gear	
87	コード押えテープ Retaining tape		589-6	軸受板 Bearing plate	
155	P.Dテフロン線A Lead wire, PD, A		★ 590	前小ギア Front pinion	
155A	P.Dリード線A Lead wire A		590-6	前小ギア Front pinion	
156	P.Dテフロン線C Lead wire C		618-1	Tフィルムナット T-film nut	
156A	P.Dリード線B Lead wire B		623	Tフィルムバネ Spring	
232	プリズム押えシート Prism retainer		624 A, B	Tフィルム基板座金 Washer	
233	プリズム押えバネ Prism retainer spring		828	小ネジ JCIS ⊕ CM 2 x 3.5 Type (1) Screw	
237	枠板 F-mask plate		839	小ネジ JCIS ⊕ PM 1.7x4 Type (3) Screw	
★ 250	プリズムボックス Prism box		846	調整板取付ビス Screw	
★ 251	視野枠 Viewfield mask		884-5	受板ビス JCIS ⊕ PM 1.7x3 Type (1) Screw	
★ 252	間隔枠 Spacer		★ 885	前小ギア取付ビス Screw	
252-6	間隔枠 Spacer				
253	プリズム絞り板 Prism mask		★ B-2	前板部 Front plate	
262-5	フレネル板枠 Focusing screen frame		B-6	前板部 Front plate	

部品番号 Part No.	名称 Name	備考 Remarks	部品番号 Part No.	名称 Name	備考 Remarks
33FB ★ B2	セルフ連動レバー Self-timer coupling lever		P33FB 845-5	小ネジ JCIS ⊕ CM 2.0x3.0 Type (1) Screw	
B2-6	セルフ連動レバー Self-timer coupling lever		875	止めネジ Set screw	
B16-5	45° ストッパー 45° stopper		G3	プリズム Prism	
B39-5	ミラーアップ受け Mirror-up stopper		G6	反射ミラー Aperture readout reflex mirror	
B40-6	プリズムボックス Prism box				
F7-1	Tダイヤルプーリー T-dial pulley				
N1	ミラー保持基板 F-mirror holder				
N2	ペンタ押え Penta prism retainer				
N4	接眼モールドメガネ Eyepiece mold				
N6-5	フレネル受け枠 Focusing screen frame				
P33FB					
P33FB 54 (01)(02)	セルフレバービス Self-timer lever screw				
55	セルフレバー用革 Leatherette				
810	前板取付ビス Front plate screw				
812-5	小ネジ JCIS ⊕ PM 1.7x2.5 Type (1) Screw				
817	小ネジ JCIS ⊕ PM 2.0x5.0 Type (3) Screw				
830	小ネジ JCIS ⊕ PM 1.4x2.0 Type (3) Screw				
842 A~V	調整座金 Washer				

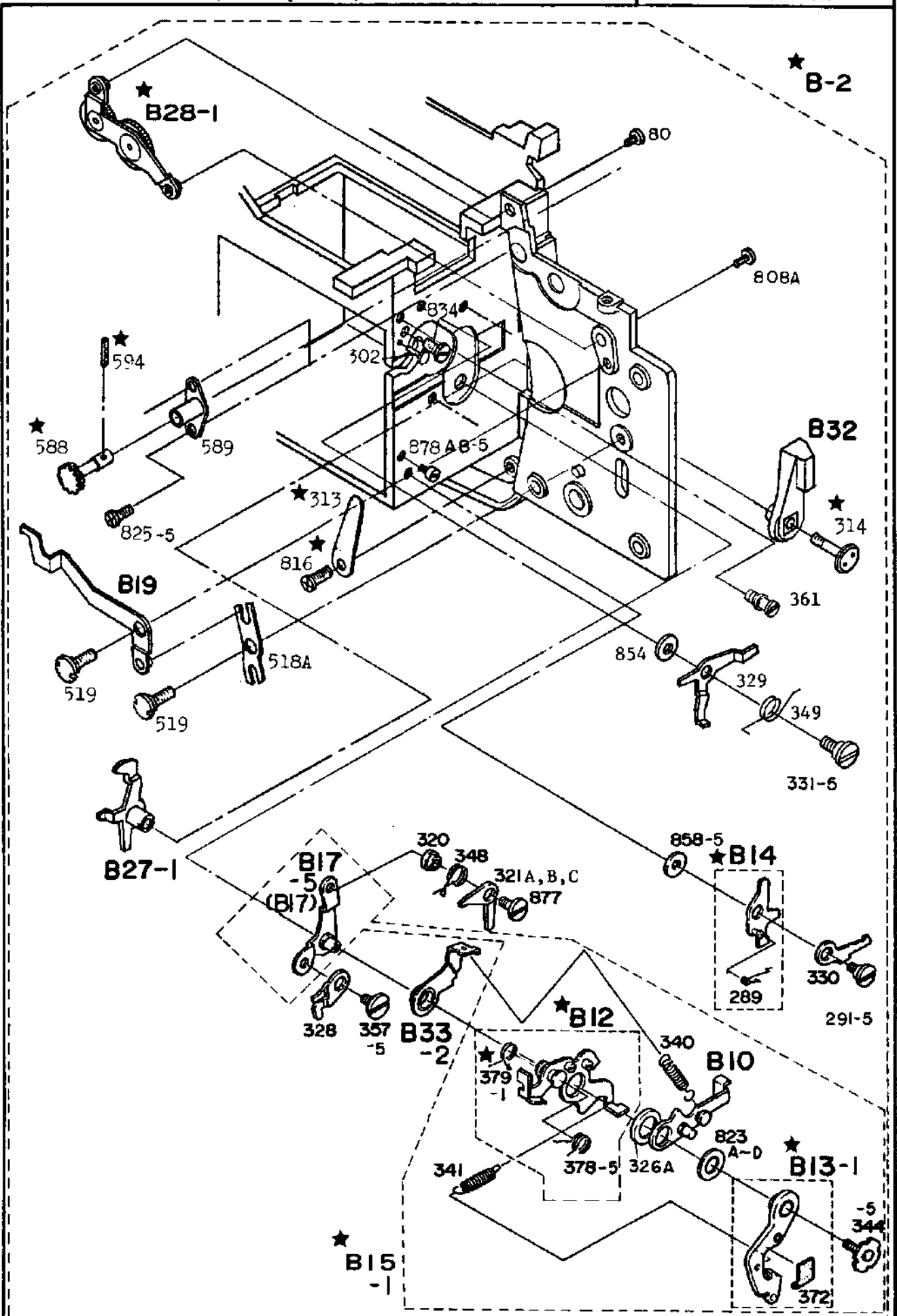


Fig. 9

NEW

B-6

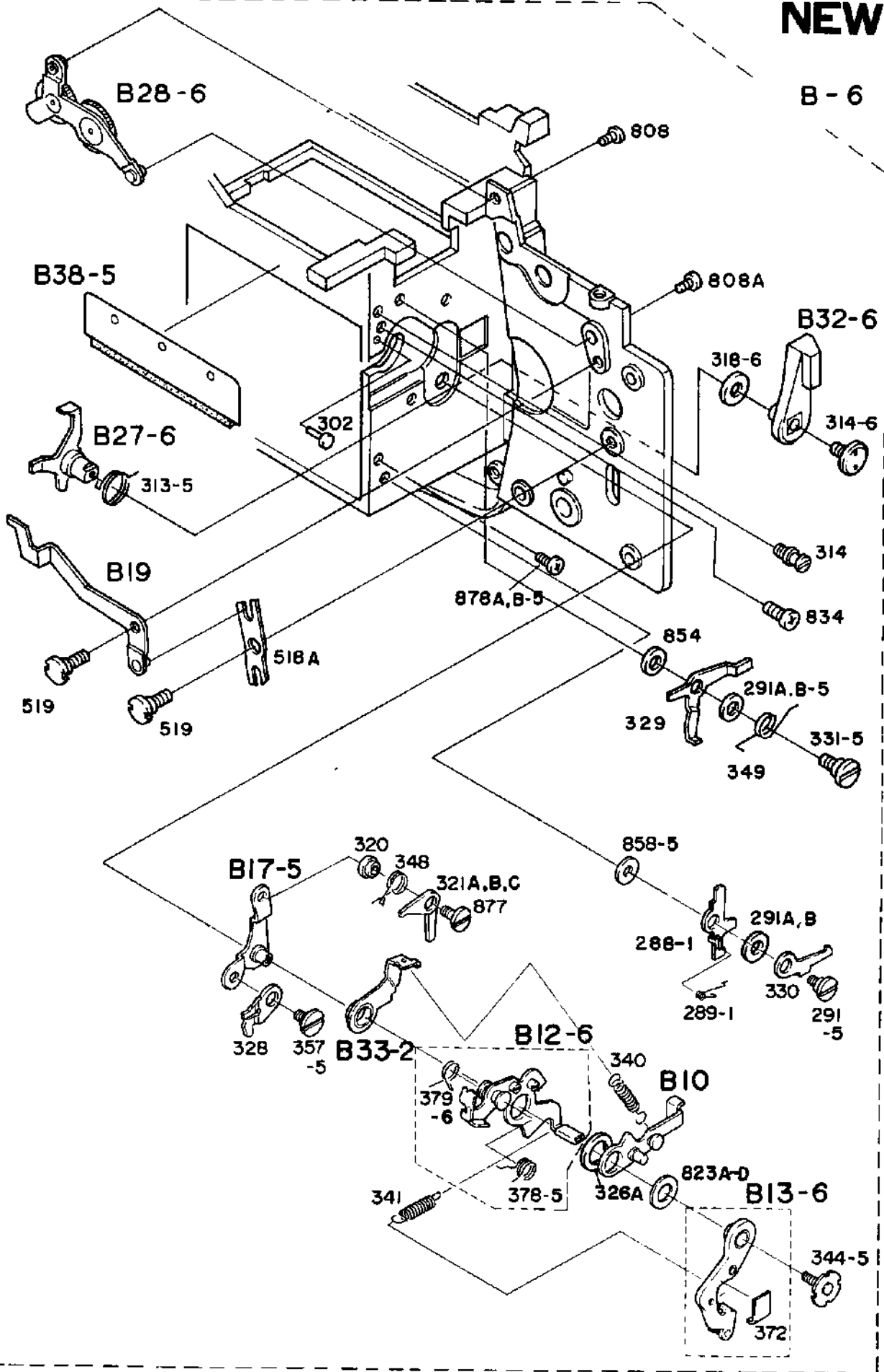


Fig. 9-1

部品番号 Part No.	名称 Name	備考 Remarks	部品番号 Part No.	名称 Name	備考 Remarks
33FB 291-5	係止レバー軸 Latch lever axle		854	ミラーアップ押えレバー座金 Washer	
302	巻上側チリトリ回転軸 Mirror shaft		858-5	ミラーボックス座金 Washer	
★ 313	手動絞りレバーばね Manual stop-down lever		877	シャッターレリーズレバー軸 Release lever axle	
★ 314	絞りレバービス Stop-down lever screw		878 A-5	ダウン係止レバーストッパー Down-stopper lever stopper	
314-6	絞りレバービス Stop-down lever screw		878 B-5	ダウン係止レバーストッパー Down-stopper lever stopper	
320	シャッターレリーズカラー Collar				
321 A~C	シャッターレリーズレバー Shutter release lever		★ B-2	前板部 Front plate	
329	ミラーアップ押えレバー Mirror-up lever		B-6	前板部 Front plate	
331-5	ミラーアップ押えレバー軸 Mirror-up lever axle		★ B12	ミラーアップレバー Mirror-up lever	
348	シャッターレリーズばね Shutter release spring		B12-6	ミラーアップレバー Mirror-up lever	
349	ミラーアップ押えばね Mirror-up spring		★ B13-1	ミラーダウンレバー Mirror-down lever	
357-5	シグナルレバー止めビス Signal lever screw		★ B15-1	5点セット Mirror actuating unit	
361	ミラーアップ押えレバーばね掛け Signal stud		B17-5	ミラーレバー軸取付板 Mirror lever base plate	
518A	レリーズレバー二股 Release lever fork		B19	レリーズレバー Release lever	
519	レリーズレバー軸 Release lever axle		B27-1	手動絞りレバー Stop-down coupling lever	
★ 588	軸付ギア Gear		★ B28-1	アイドルギア基板 Idle gear base plate	
589	ギア軸受 Gear bearing		B28-6	アイドルギア基板 Idle gear base plate	
★ 594	Sロールピン Spring pin		B32	絞り込みレバー Stop-down lever	
★ 816	小ネジ JCIS ⊕ PM 2 x 2 Type (3) Screw		B32-6	絞り込みレバー Stop-down lever	
834	チリトリピン押えビス Screw				

部品番号 Part No.	名称 Name	備考 Remarks	部品番号 Part No.	名称 Name	備考 Remarks
P33FB			P33FB ★ B14	ミラーダウン信号レバー Mirror-down signal lever	
P33FB 288-1	ミラーダウン信号レバー Mirror-down signal lever		B27-6	手動絞りレバー Manual stop-down lever	
289-1	ミラー係止レバーバネ Mirror-holder lever spring		B33-2	絞りレバーバネ掛け Diaphragm spring stub	
313-5	手動絞りレバーバネ Manual stop-down lever spring		B38-5	ミラーボックス後部遮光板 Mirror box rear light-tight plate	
318-6	手動絞りレバー座 Manual stop-down lever plate				
326A	チェンジレバー軸 Change lever axle				
328	シグナルレバー Signal lever				
330	ミラーダウン係止レバー Mirror-down latch lever				
340	絞りレバーバネ Diaphragm actuating lever spring				
341	ミラーアップバネ Mirror-up spring				
344-5	レバー押えビス Mirror holder screw				
372	防振用ゴム Cushion rubber				
378-5	ミラーズプリング (大) Mirror spring (L)				
★379-1	ミラーズプリング (小) Mirror spring (S)				
379-6	ミラーズプリング (小) Mirror spring (S)				
823 A~D	ミラーレバー軸調整用座金 Washer				
825-5	小ネジ JCIS ⊕ PM 2.0x2.5 Type (1) Screw				
B10	絞りレバー Diaphragm actuating lever				
B13-6	ミラーダウンレバー Mirror-down lever				

Front plate (rewind side)

前板部 (巻戻側)

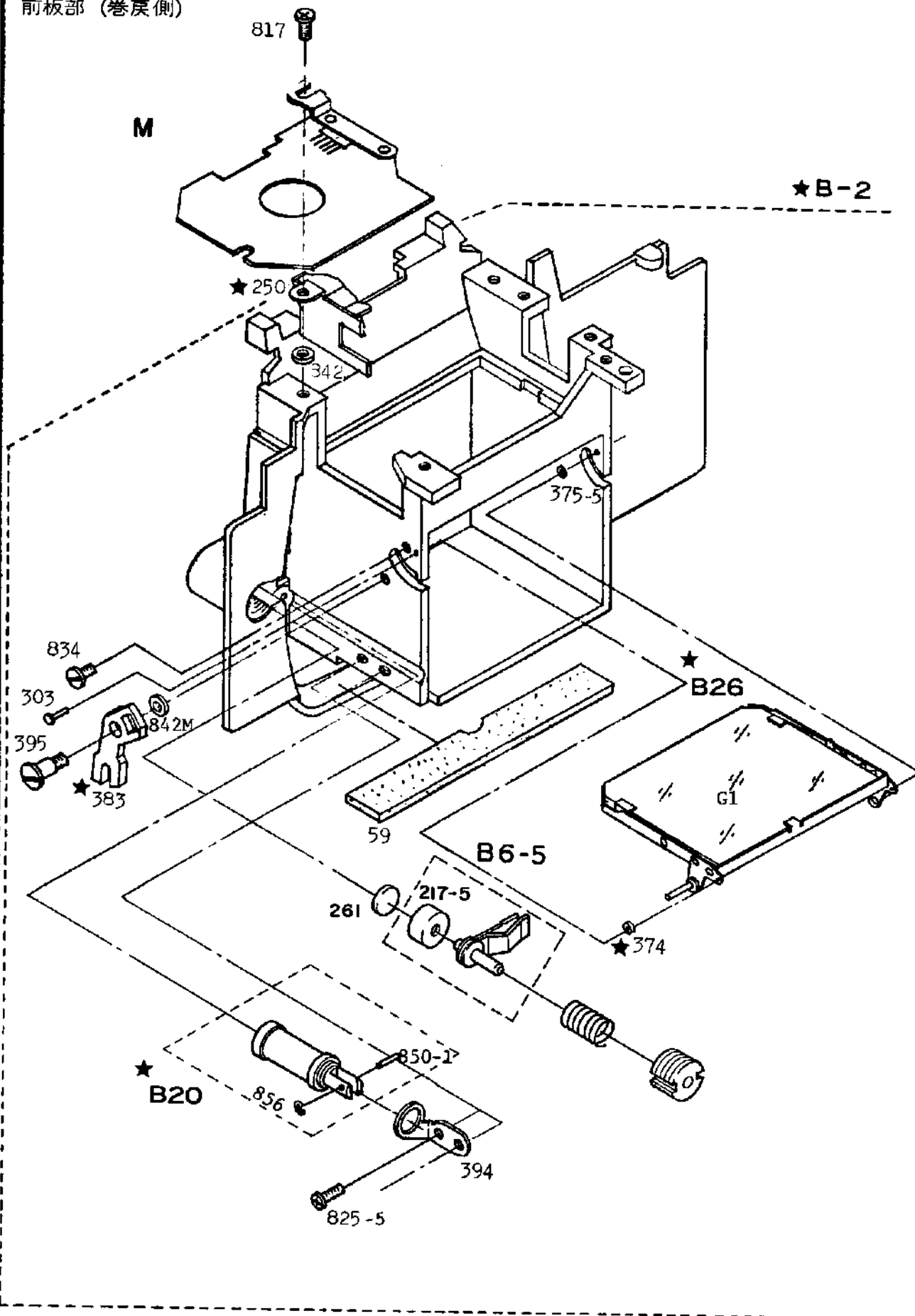
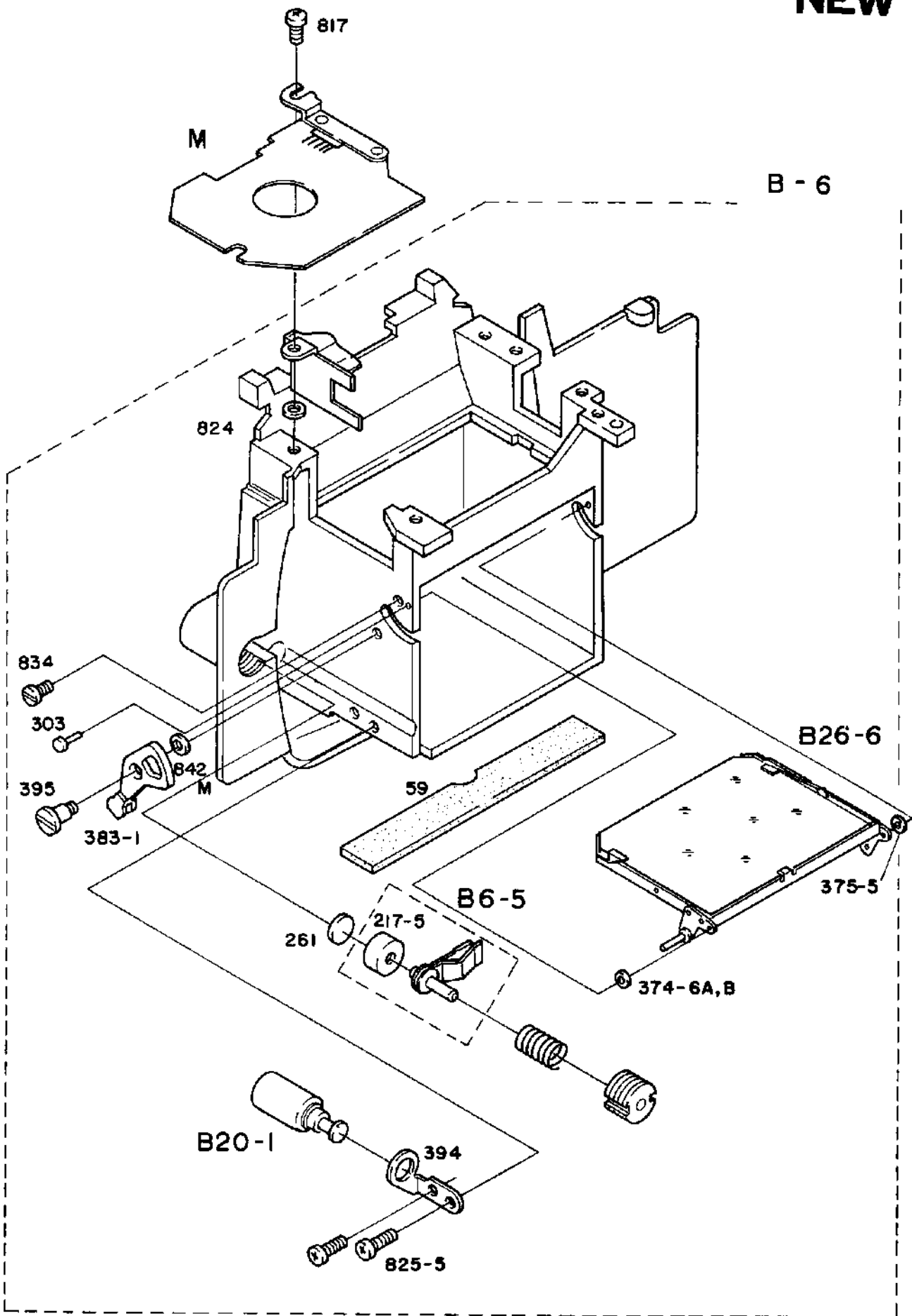


Fig.10

NEW



B - 6

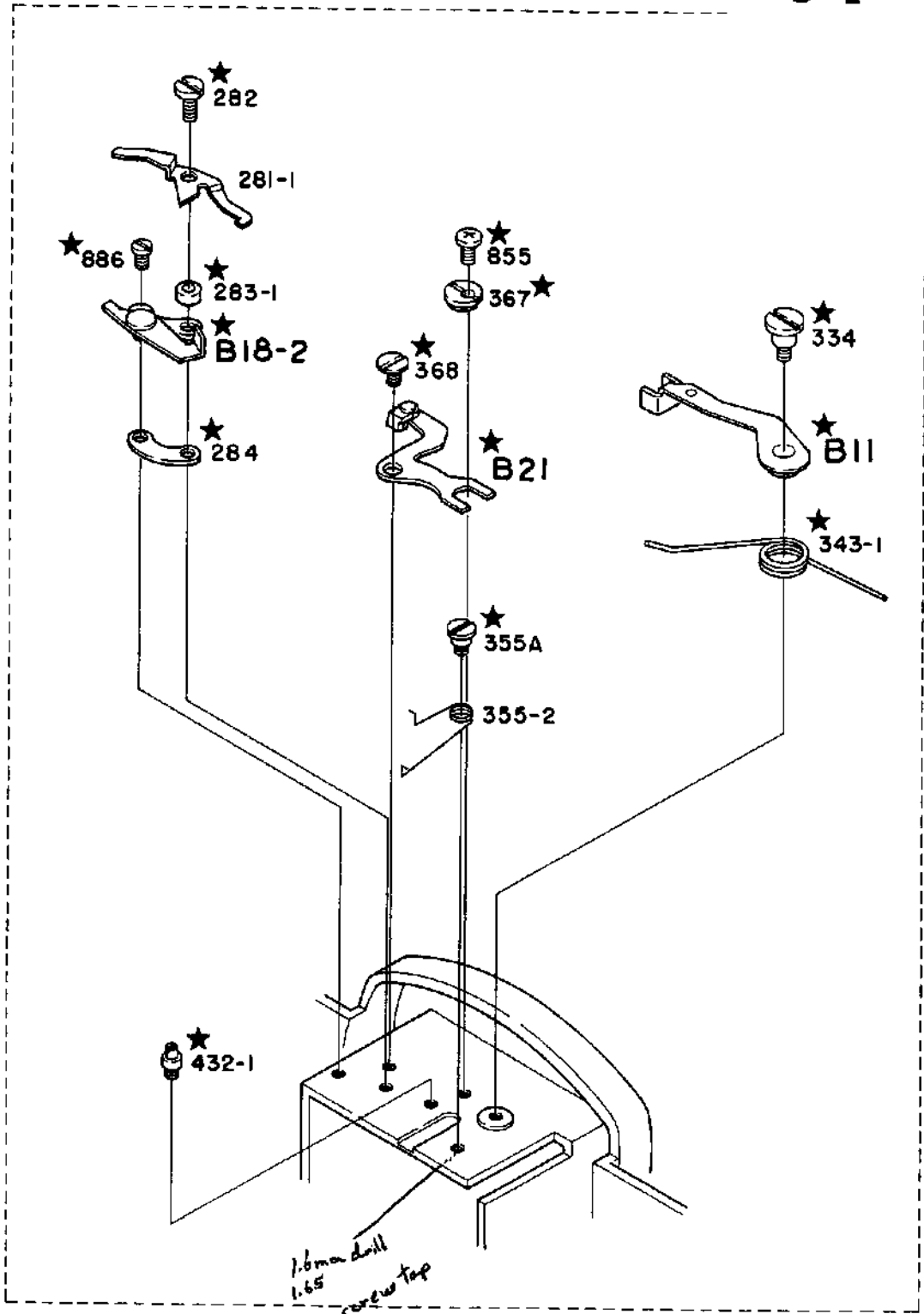
B26-6

B6-5

B20-1

Fig.10-1

★ B-2



Jig ~~15~~ J15160

Fig. 11

NEW

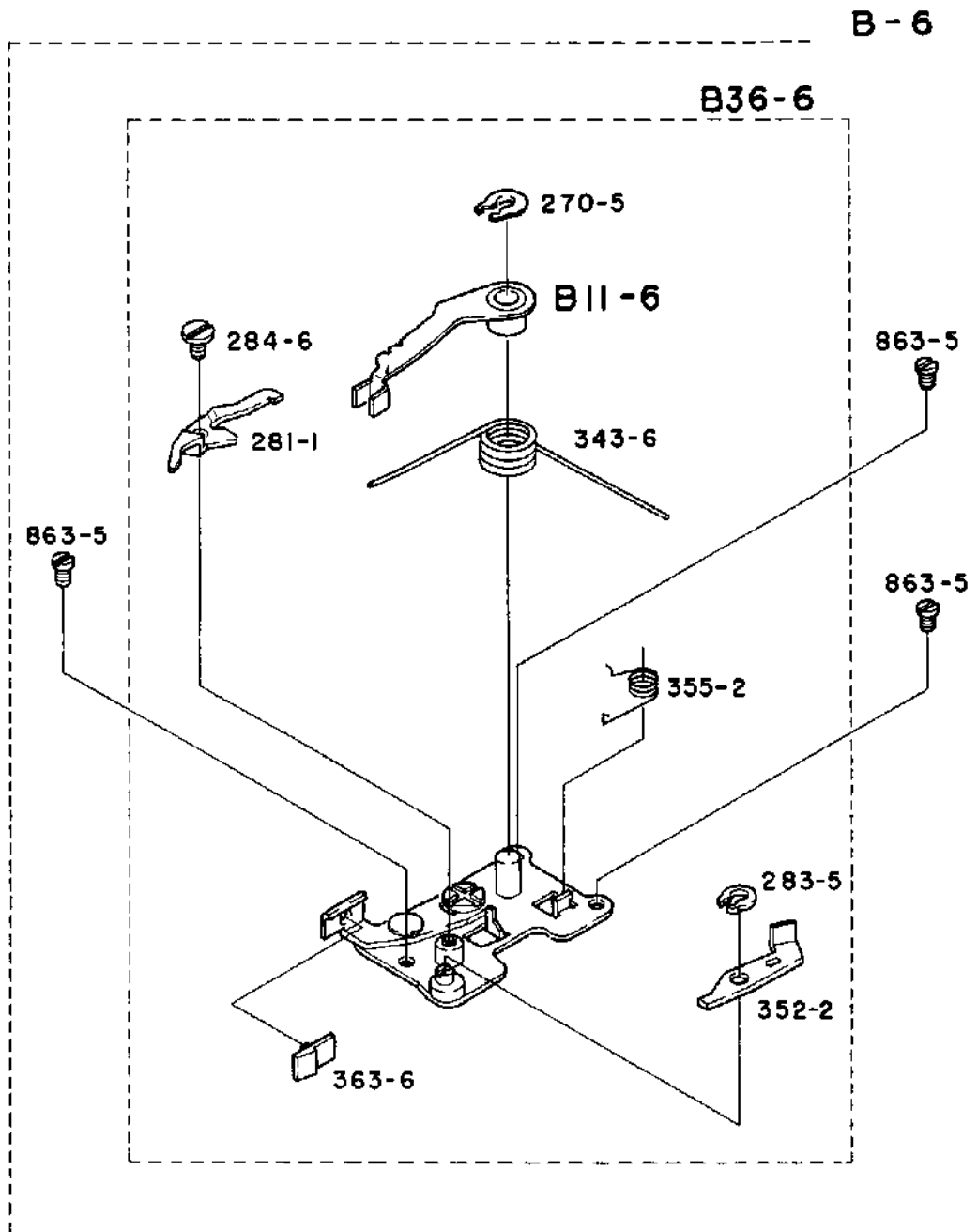


Fig.11-1

部品番号 Part No.	名称 Name	備考 Remarks	部品番号 Part No.	名称 Name	備考 Remarks
33FB ★ 282	ブレーキ解除軸 Brake release shaft		P33FB		
★ 283-1	ブレーキ解除軸カラー Collar		P33FB 270-5	グリップリング Grip ring	
★ 284	中間レバー座金 Brake middle-lever base		281-1	保持レバー Retaining lever	
★ 334	大レバー軸 Mirror change lever axle		283-5	グリップリング Grip ring	
★ 342-1	保持レバー制限 Link lever stopper		284-6	ブレーキ解除軸 Brake release shaft screw	
★ 343-1	ダウンばね Mirror-down spring		352-2	MD 巻き上げ信号中間レバー MD take-up signal middle lever	
343-6	ダウンばね Mirror-down spring		355-2	保持レバーばね Spring	
★ 355A	保持レバーばね軸 Lever spring axle		363-6	ダウンレバー緩衝ゴム Shock absorb rubber	
★ 367	調整レバー偏心軸 Down lever eccentric		863-5	M. Box 下基板ビス Screw	
★ 368	ダウンレバー調整レバー軸 Down lever adjust axle				
★ 855	小ネジ JCIS ⊕ PM 2x3.5 Type (3) Screw		B11-6	大レバー Mirror change lever	
★ 886	中間基板止めビス Screw				
★ B-2	前板部 Front plate				
B-6	前板部 Front plate				
★ B11	大レバー Mirror change lever				
★ B18-2	中間レバー基板 Mirror lever base plate				
★ B21	ダウンレバー調整レバー Down lever adjustor				
B36-6	底基板 Bottom base plate				

Body
ボディ

remove part of
screw head underneath

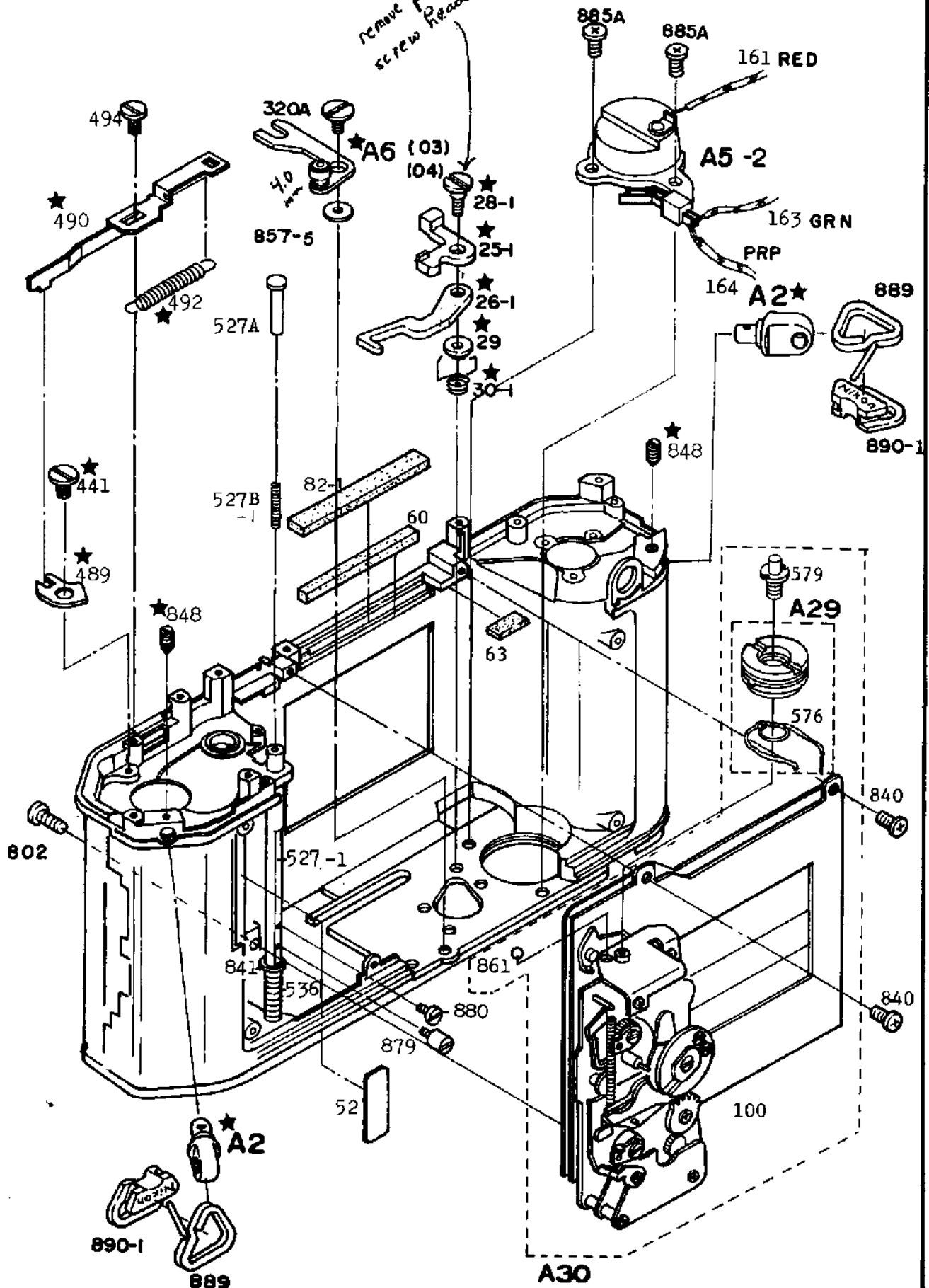


Fig.12

NEW

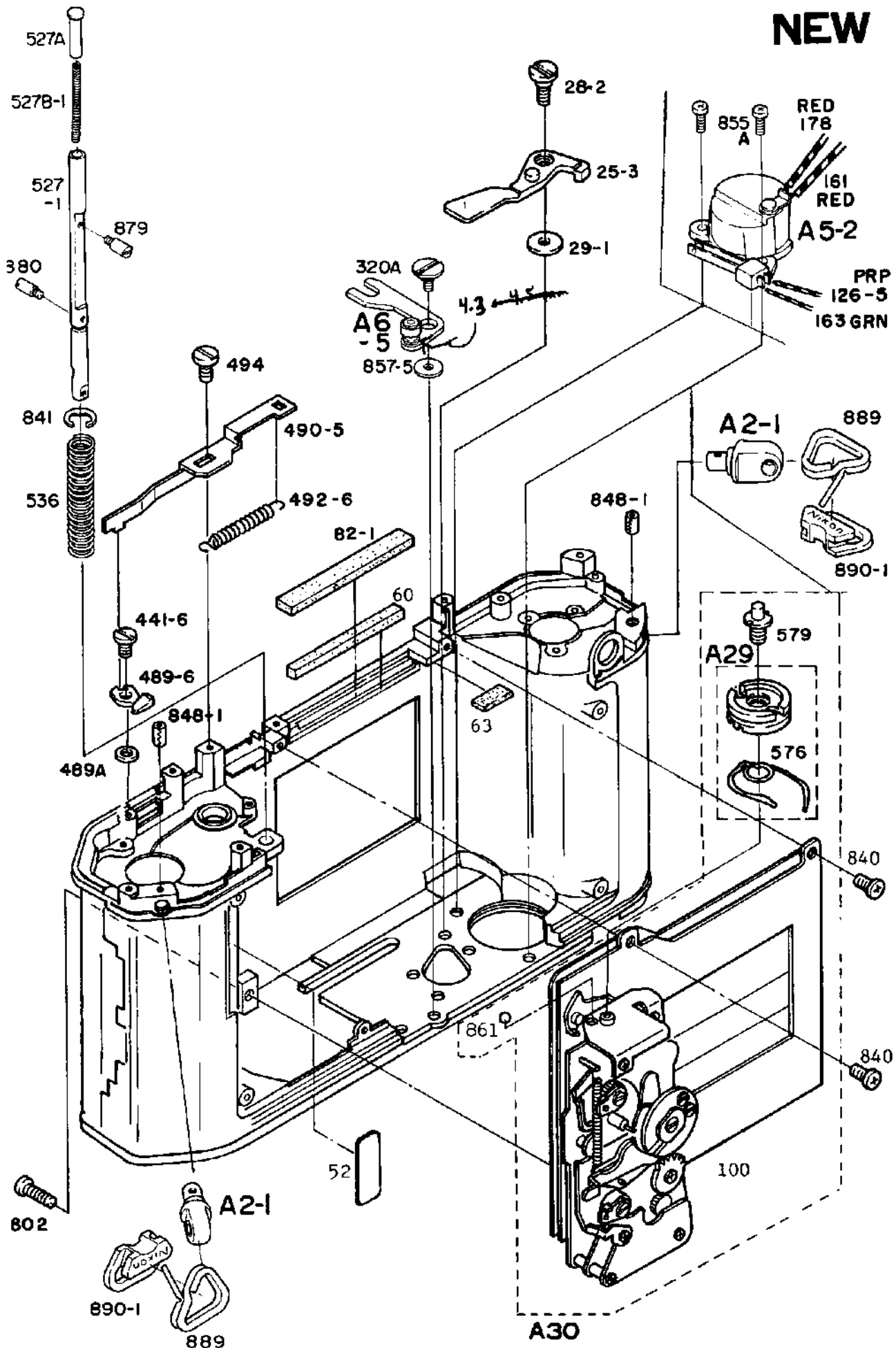


Fig. 12-1

部品番号 Part No.	名称 Name	備考 Remarks	部品番号 Part No.	名称 Name	備考 Remarks
33FB 52	コード溝カバー Lead wire cover		P33FB		
161	MD測光用電源リード線A Lead wire, power source A		P33FB ★ 25-1	MD SW 連動レバー Motor switch coupling lever	
163	後幕シグナルリード線A Lead wire, rear curtain signal A		25-3	MD SW 連動レバー Motor switch coupling lever	
178	測光用電源リード線 Lead wire, power source		★ 26-1	空撮り防止レバー Motor switch coupling lever	
★ 490	多重撮りアーム Multi-exposure arm		★ 28-1	MD信号レバー軸 MD signal lever axle	
490-5	多重撮りアーム Multi-exposure arm		28-2	MD信号レバー軸 MD signal lever axle	
★ 492	多重撮りアーム戻しばね Spring		★ 29	空撮り防止レバー軸カラー Blank exposure preventer lever collar	
492-6	多重撮りアーム戻しばね Spring		29-1	MD信号レバー座金 MD signal lever washer	
494	ガイドピン Guide pin		★ 30-1	MD信号レバーバネ MD signal lever spring	
527-2	リリース軸 Release shaft		60	接眼下部遮光モルト Light-tight (for eyepiece)	
571	クリックプーリー Click pulley		63	シャッター羽根受けゴム Shutter curtain rubber	
576	シャッター変速糸 T-dial string		82-1	シャッター上遮光モルト Light-tight, shutter top	
579	プーリー段ビス Shoulder screw		126-5	上地スイッチコード Switch cord	
618-1	Tフィルムナット T-film nut		320A	チャージレバー軸 Charge lever axle	
623	Tフィルムばね Spring		★ 441	三羽根爪外しレバー軸 Charge cam claw release lever axle	
861	シャッタークリックボール Click ball		441-6	三羽根爪外しレバー軸 Charge cam claw release lever axle	
880	Bレバー解除ビス B-lever release screw		★ 489	三羽根爪外しレバー Charge cam claw release lever	
			489-6	三羽根爪外しレバー Charge cam claw release lever	
A29	クリックプーリー Click pulley		489A	面カム外しレバー座金 Washer	
A30	シャッター Shutter		527A	リリース軸補助 Release shaft supporter	

部品番号 Part No.	名称 Name	備考 Remarks	部品番号 Part No.	名称 Name	備考 Remarks
P33FB 527B-1	リリース鉤補助バネ Spring				
536	リリース軸バネ Release shaft spring				
802	小ネジ JCIS ④ PM 2.0x7.0 Type (1) Screw				
840	小ネジ JCIS ④ CM 2.0x3.0 Type (3) Screw				
841	リリース軸用Eリング Release shaft E-ring				
★ 848	吊環ビス Eyelet set screw				
848-1	スプリングピン Spring pin				
855A	小ネジ JCIS ④ CM 2.0x4.5 Type (3) Screw				
857-5	大レバー座金 Washer				
879	リリースレバーガイド軸 Release lever guide pin				
889	三角環 Neck-strap ring				
890-1	三角環保護カバー Neck-strap ring cover				
★ A2	耳環 Eyelet				
A2-1	耳環 Eyelet				
A5-2	電池ケース Battery chamber				
A6-5	チャージレバー Charger lever				

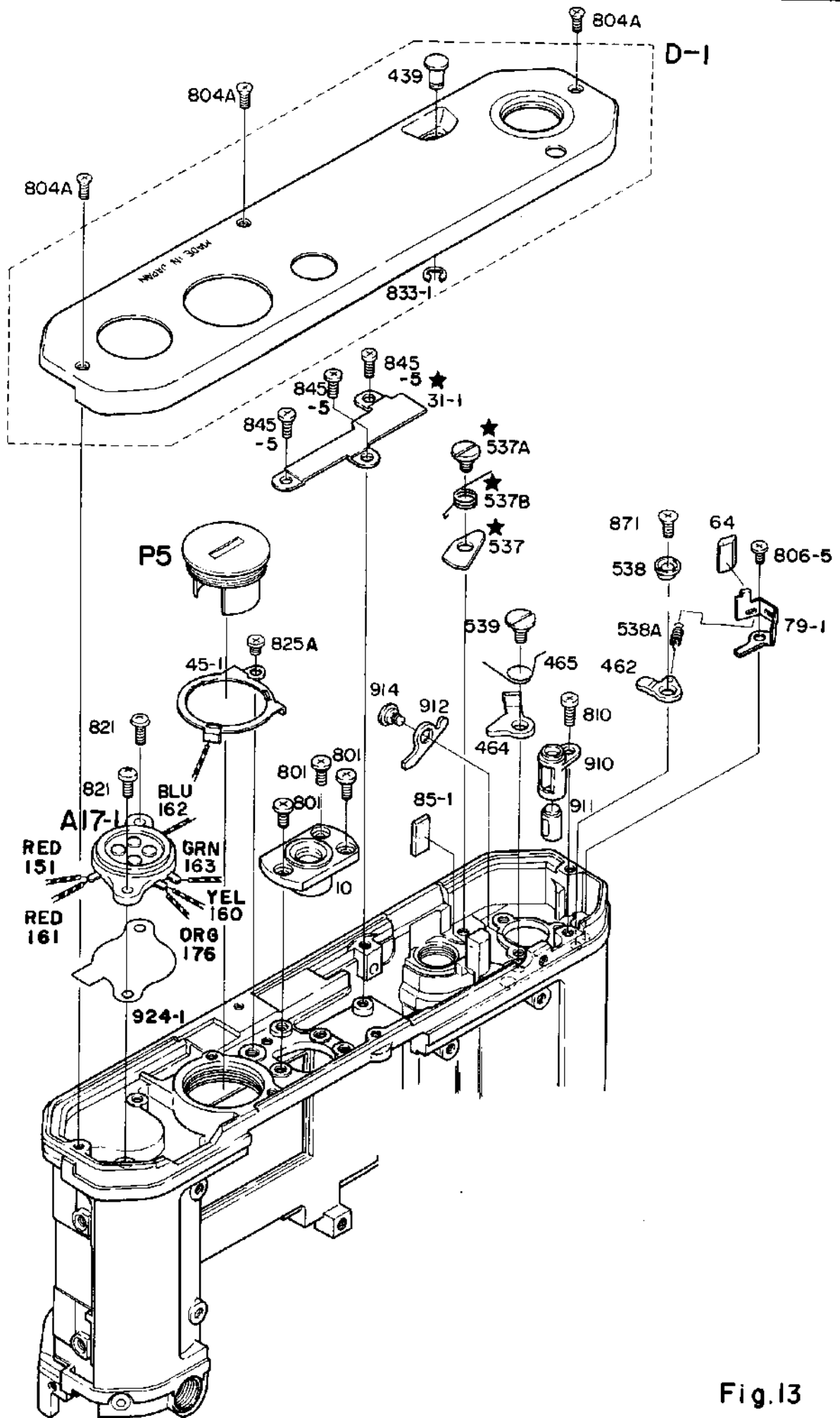


Fig.13

NEW

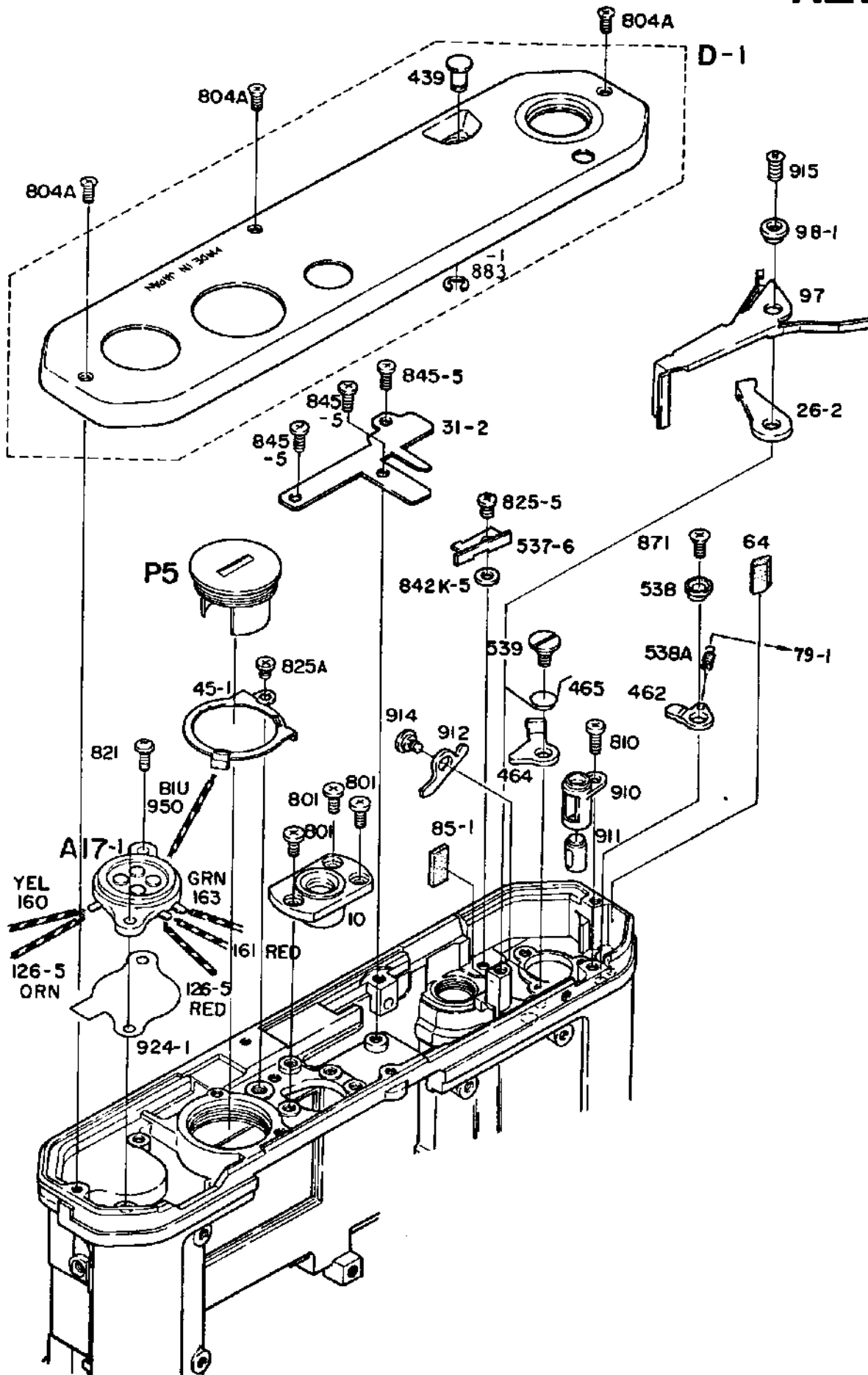


Fig. 13-1

部品番号 Part No.	名称 Name	備考 Remarks	部品番号 Part No.	名称 Name	備考 Remarks
33FB 79-1	縦衝板 Baffle plate		P33FB 465	ロックレバーバネ Lock lever spring	
160	MD測光用電源リード線A Lead wire, power source A		★ 537	ARレバー AR lever	
161	MD測光用電源リード線B Lead wire, power source B		537-6	ARレバー AR lever	
163	後幕シグナルリード線A Lead wire, rear curtain signal A		★ 357A,B	ARレバー軸 AR lever axle	
			538	振り子偏心軸 Pendulum eccentric axle	
			538A	振り子バネ Pendulum spring	
P33FB			539	ロックレバー軸 Lock lever axle	
P33FB 10	三脚座 Tripod socket		801	小ネジ JCIS ⊕ PM 2.0x3.0 Type (3) Screw	
26-2	空撮り防止レバー Blank exposure preventer lever		804A (01)(02)	小ネジ JCIS ⊕ CM 1.7x2.5 Type (1) Screw	
★ 31-1	底板押え板 Retaining plate, bottom		810	前板取付ビス Front plate screw	
31-2	底板押え板 Retaining plate, bottom		821	小ネジ JCIS ⊕ PM 2.0x4.0 Type (3) Screw	
45-1	電池アース接片 Battery chamber earth contact		825-5	小ネジ JCIS ⊕ PM 2.0x2.5 Type (1) Screw	
64	縦衝ゴムA Shock absorb rubber A		825A	小ネジ JCIS ⊕ PM 2.0x2.5 Type (3) Screw	
85-1	シャッターチャージレバー受ゴム Charge lever base rubber		842K-5	調整座金 Washer	
97-1	空撮り防止作動バネ Blank exposure preventer spring		845-5	小ネジ JCIS ⊕ CM 2.0x3.0 Type (1) Screw	
98	空撮り防止レバー軸 Blank exposure preventer lever axle		883	Rボタン用Eリング E-ring	
126-5	上地スイッチコード Switch cord		871	振り子偏心軸ビス Eccentric screw	
439	巻戻鈕 Rewind button		910	MD軸受 MD shaft bearing	
462	振り子 Pendulum		911	MD軸 MD shaft	
464	ロックレバー Lock lever		912	MDシーソーレバー MD see-saw lever	

NEW

E 1

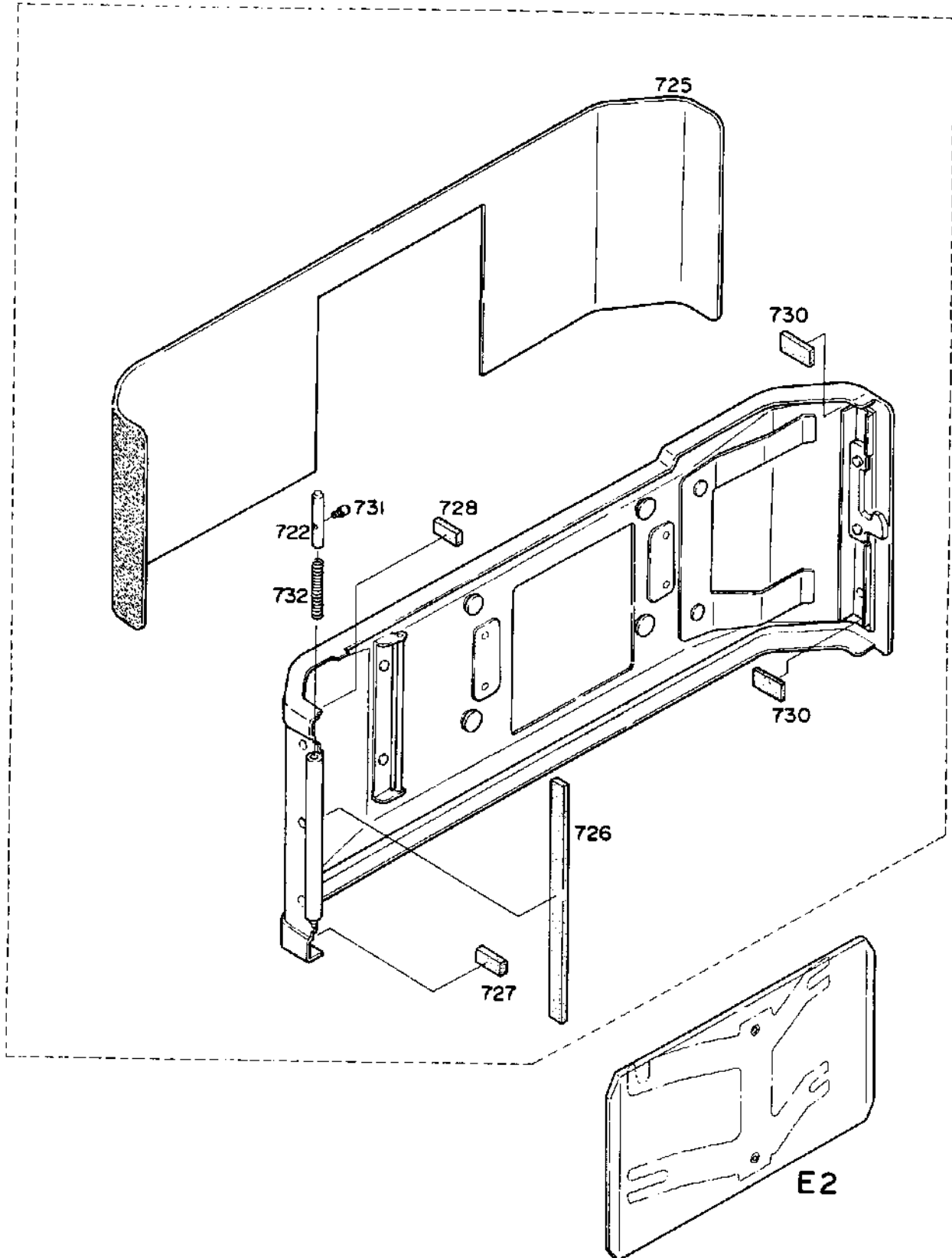


Fig. 14-1

NEW

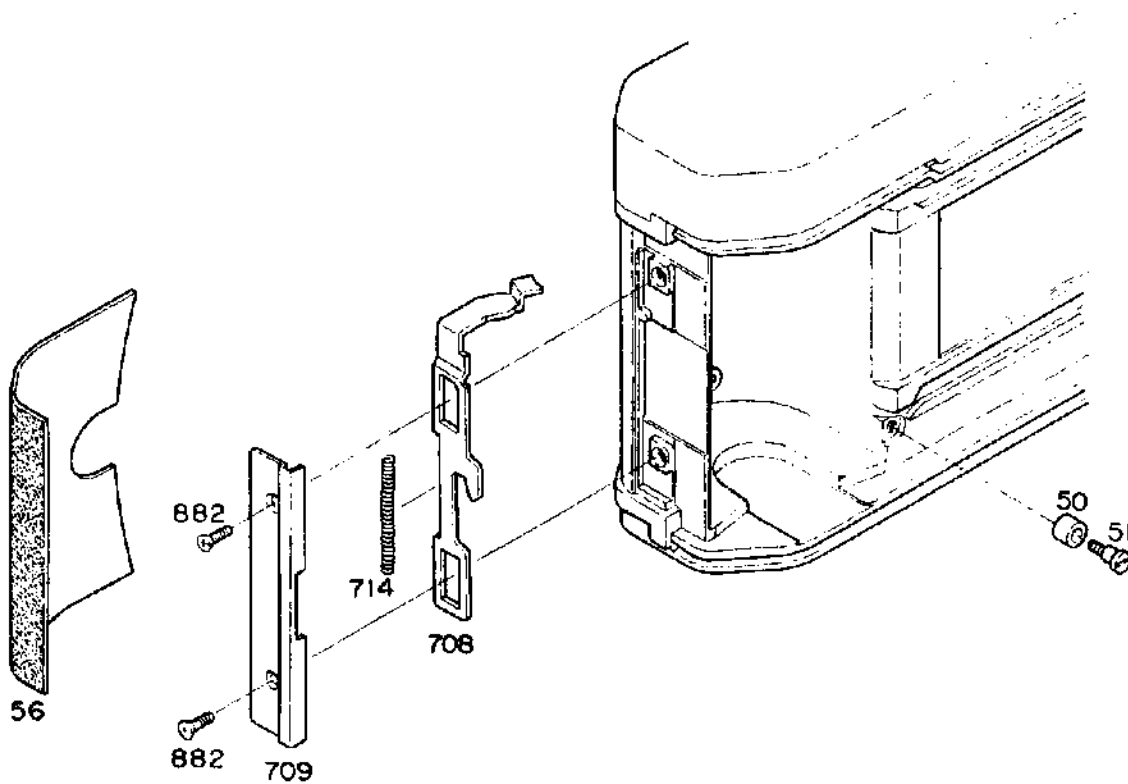
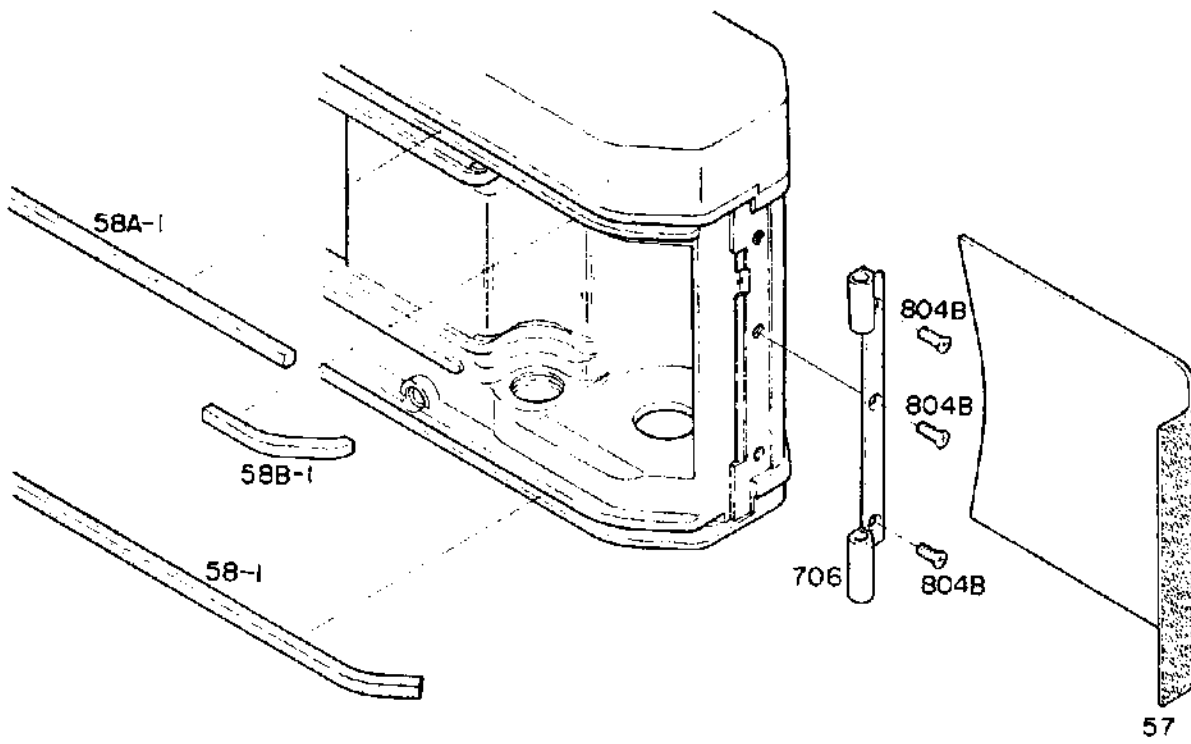
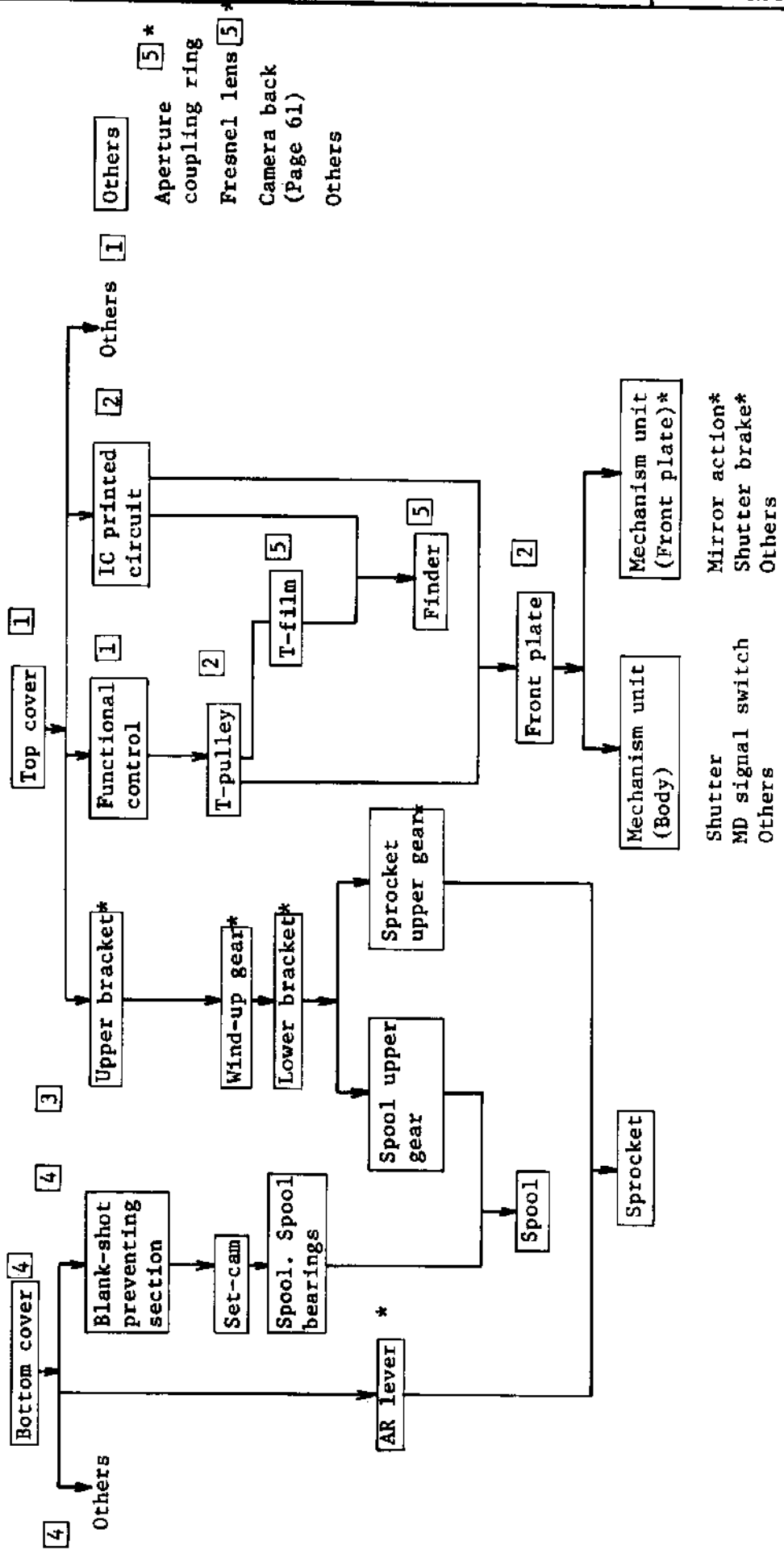


Fig. 15-1

Roughly sequence of disassembly



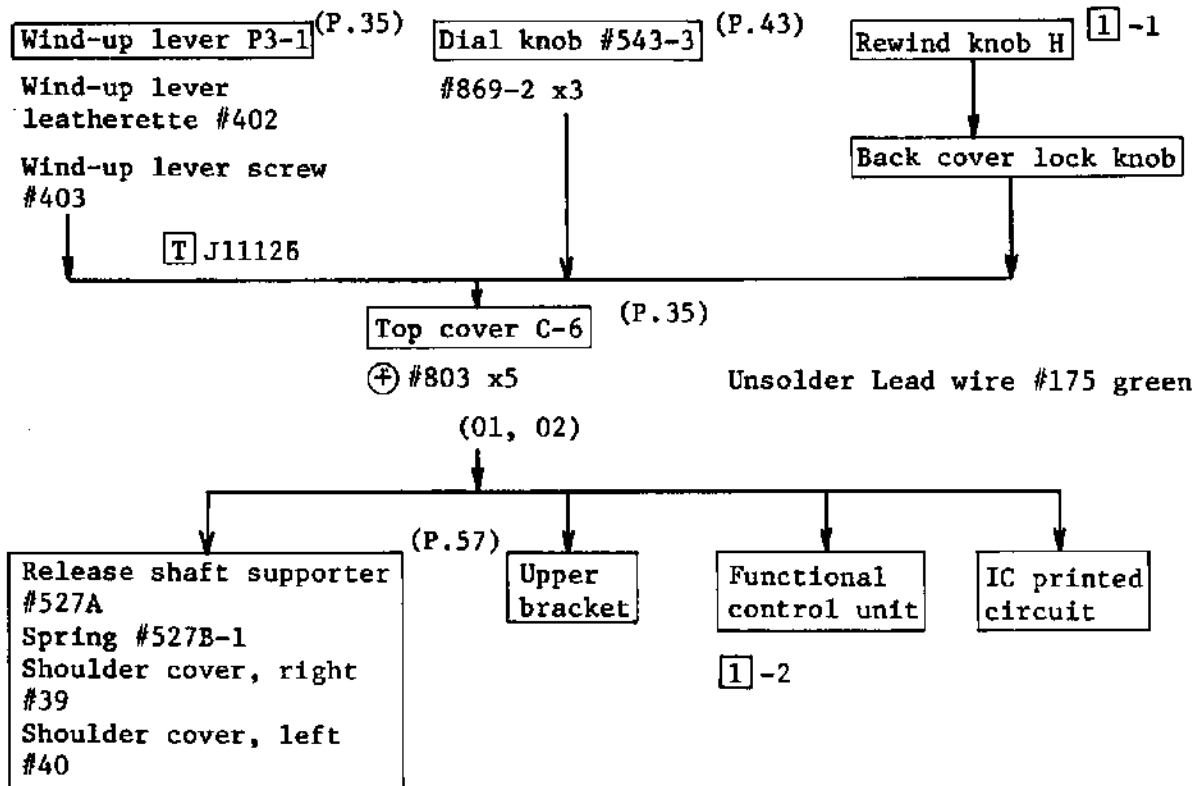
Note: * shows an unit of modification.

1 shows a section number of disassembly sequence for each unit.

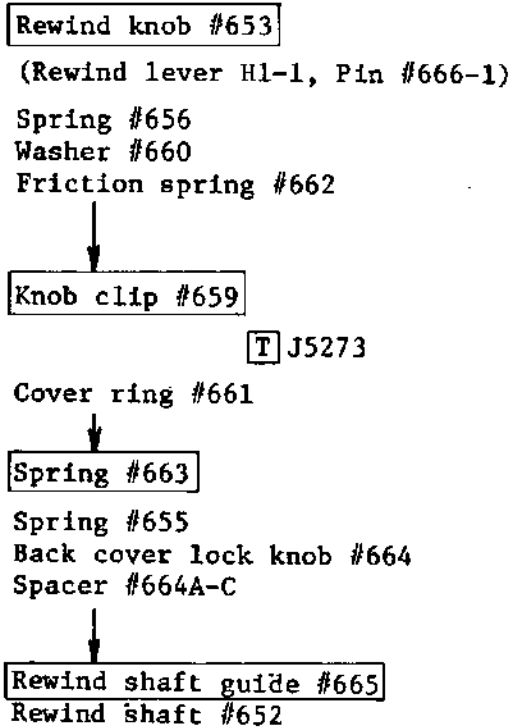
- Others
- Aperture coupling ring
- Fresnel lens
- Camera back (Page 61)
- Others

- Mechanism unit (Front plate)*
- Mirror action*
- Shutter brake*
- Others

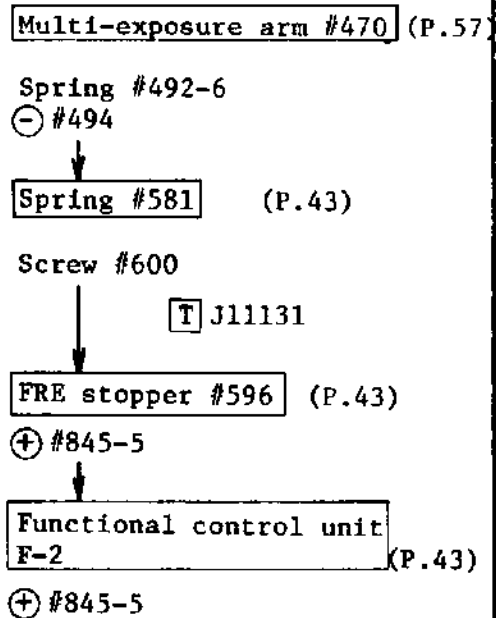
- Mechanism unit (Body)
- Shutter
- MD signal switch
- Others

Disassembly sequence **1** (Top cover)

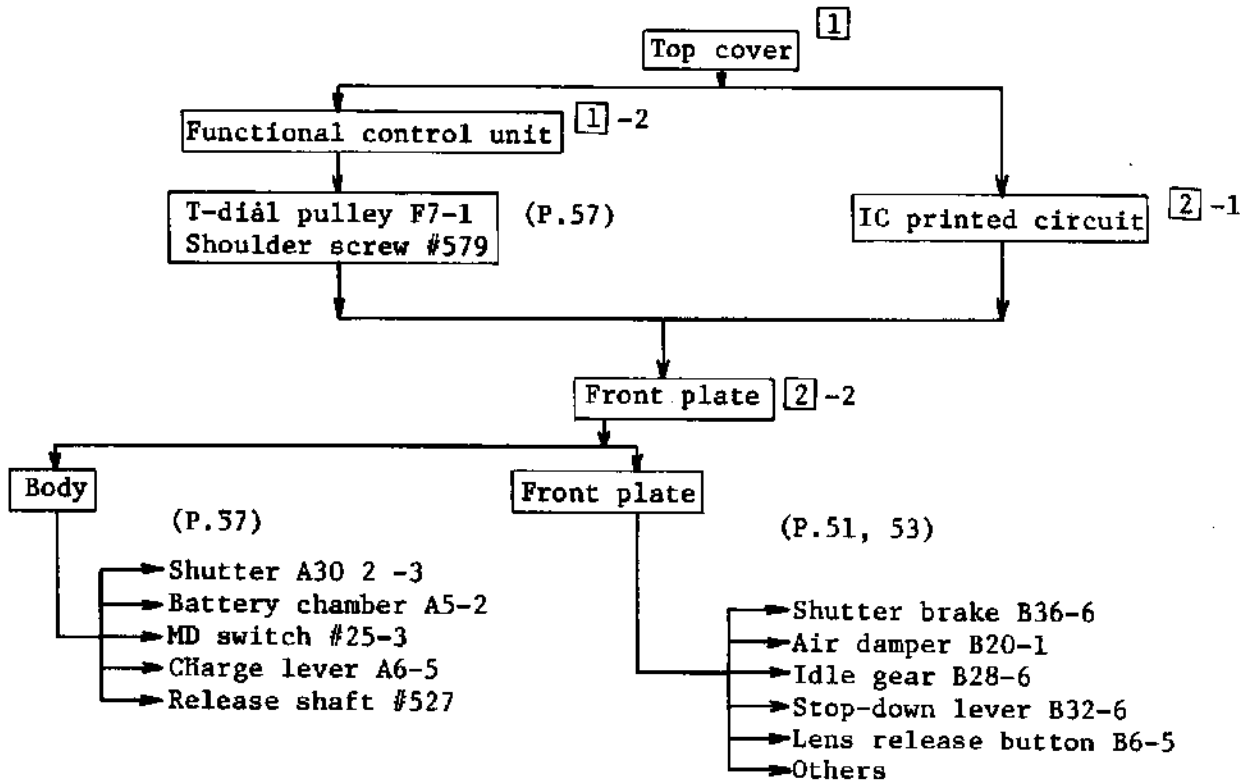
1-1 Rewind knob Back cover lock knob
(P.45)



1-2 Functional control unit



Disassembly sequence 2 (Front plate)



2-1 IC printed circuit

Unsolder FRE lead wire #152 (pink) (P.45)
 Lead wire A #160 (yellow)
 Lead wire #177 (black)
 Lead wire #161 (red)

⊕ Eyepiece mold N4 (P.49)

⊕ #817 x2

⊕ Washer #824 can fall.

⊕ IC printed circuit M (P.45)

⊕ #801

⊕ #817

2-2 Front plate

Leatherette #55 (P.49)
 Self-lever screw #54
 Self-timer lever B1

⊕ Leatherette A #56 (P.63)
 ⊕ Leatherette B #57

⊕ Front plate B-6 (P.51)

⊕ #810 x5

⊕ #839-1

2-3 Shutter (P.57)

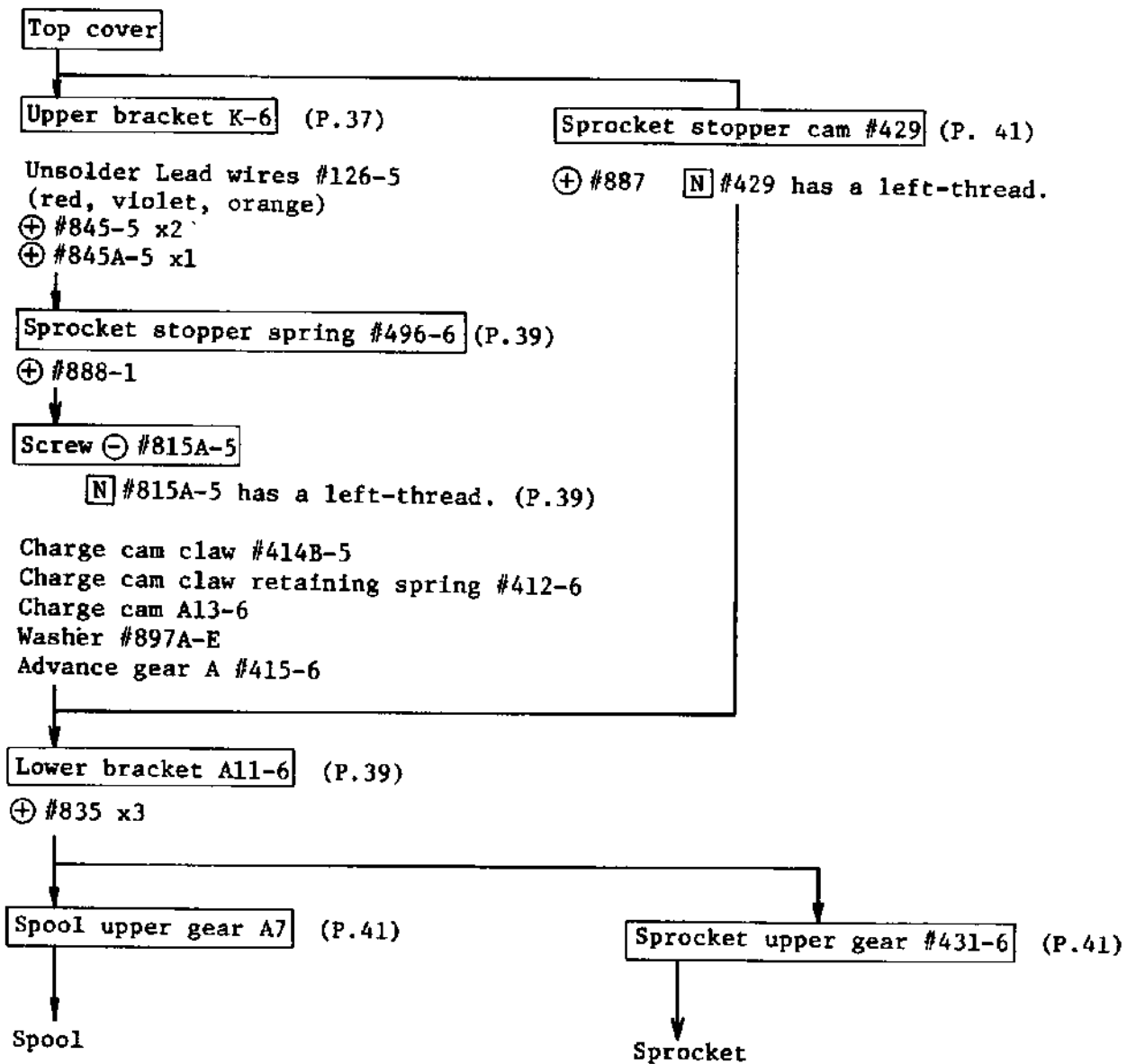
Mirror box rear light-tight #82

⊕ Shutter A30 (#100)

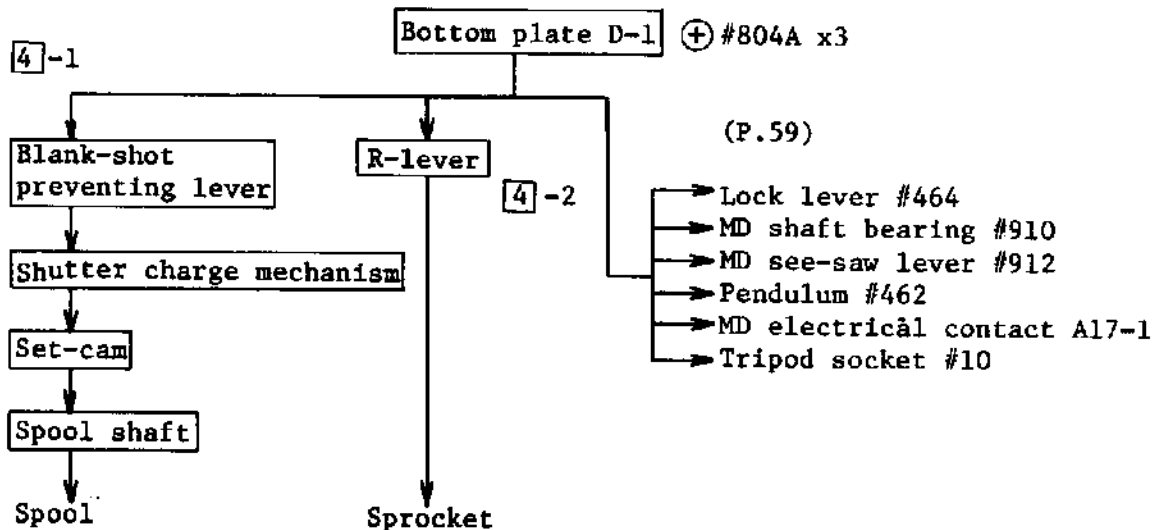
⊕ #802

⊕ 840 x2

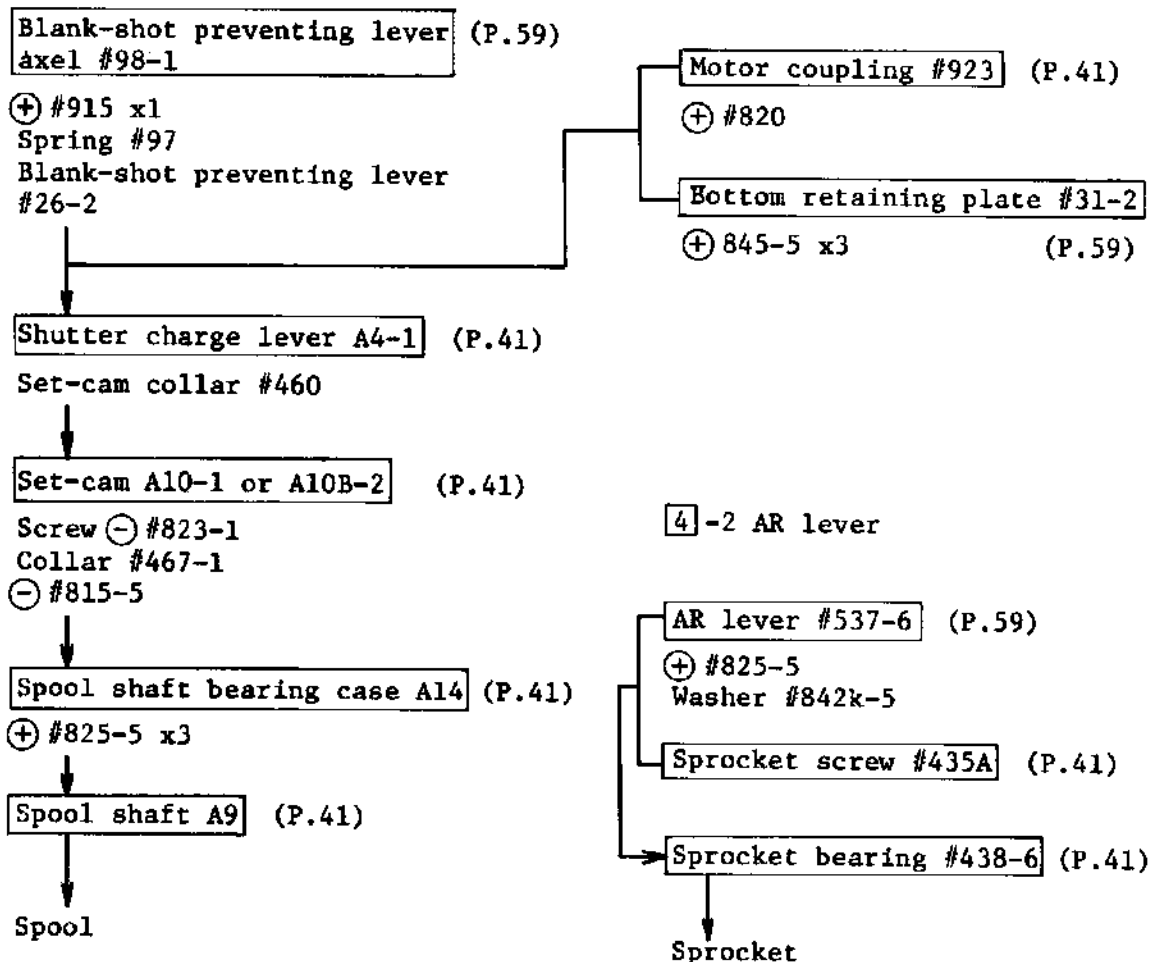
⊕ Unsolder the green lead wire.

Disassembly sequence **3** (Upper and lower bracket)

Disassembly sequence 4 (Body, bottom section)



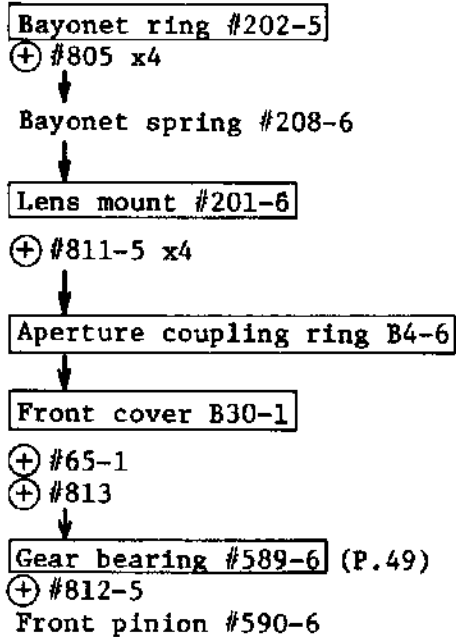
4-1 Blank-shot preventing lever and Set-cam



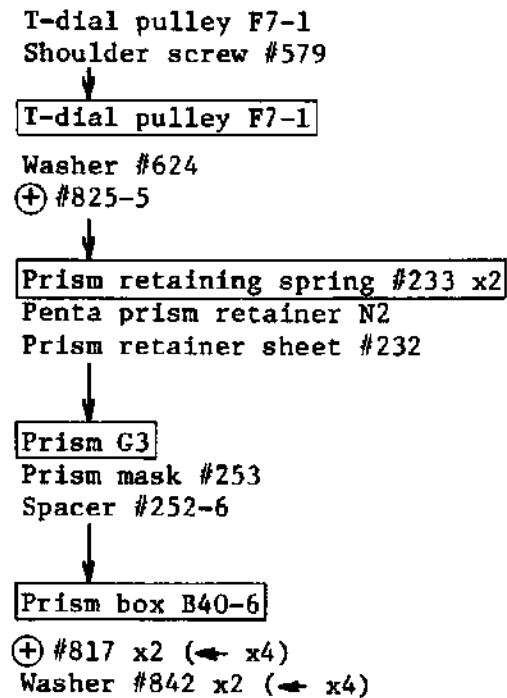
N To remove the sprocket, first depress Sprocket shaft #434-6 to disengage it from Sprocket shaft bearing #432-6, next tilt it to one side.

Disassembly sequence [5] (Bayonet ring, etc.)

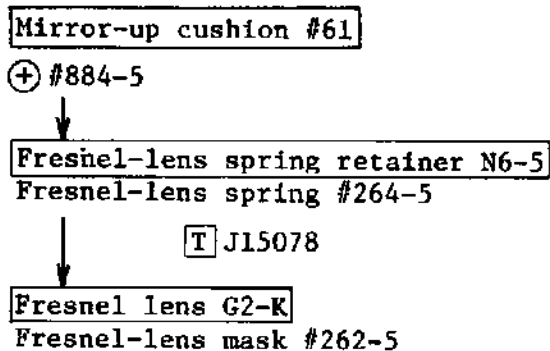
[5]-1 Bayonet ring (P.47)



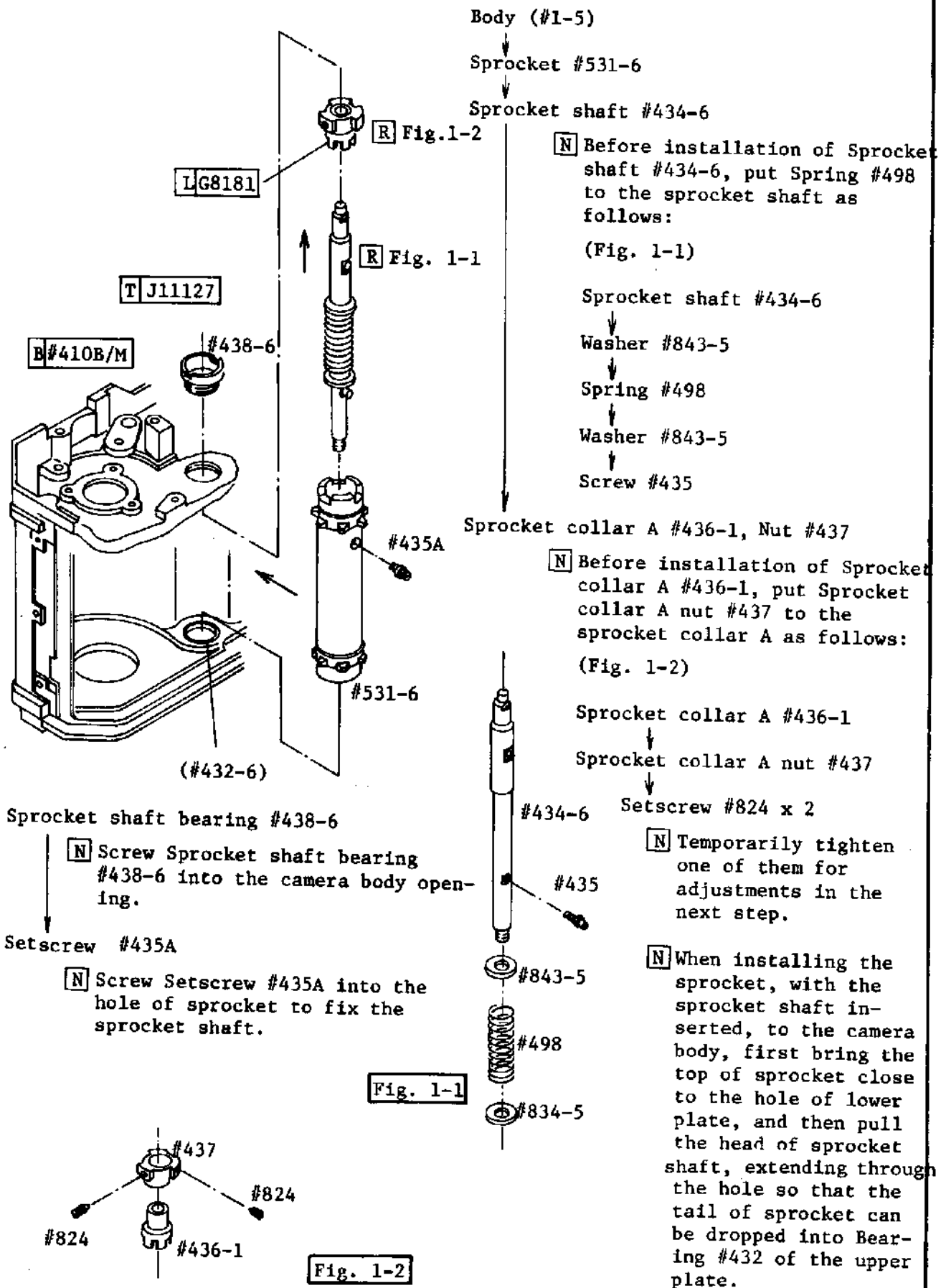
[5]-2 T-film, Finder (P.49)



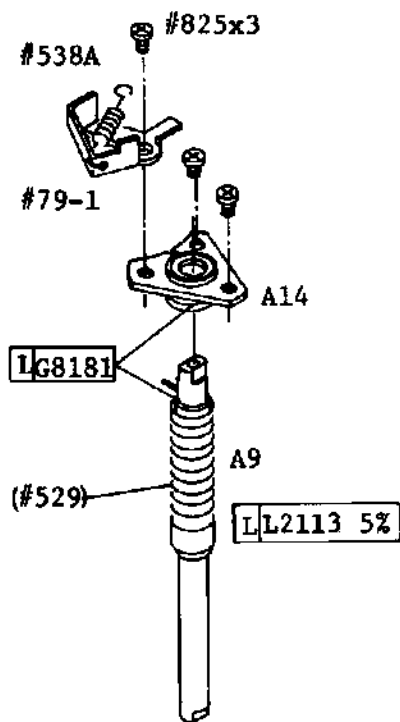
[5]-3 Fresnel lens (P.49)



(2) Reassembly and adjustment

1-1 Sprocket installation (Hold the camera body upside down)

3-1 Spool installation



Spool A8
 ↓
 Spool shaft A9
 ↓
 Spool shaft bearing case A14

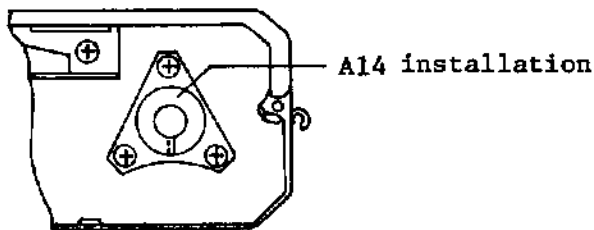
[R] **[N]** After installing the spool in place, insert the top end of Spool shaft A9 into the slit of the spool shaft bearing case.

[R] Figure 2-1 shows the fixed position of the bearing case with tightening three screws.

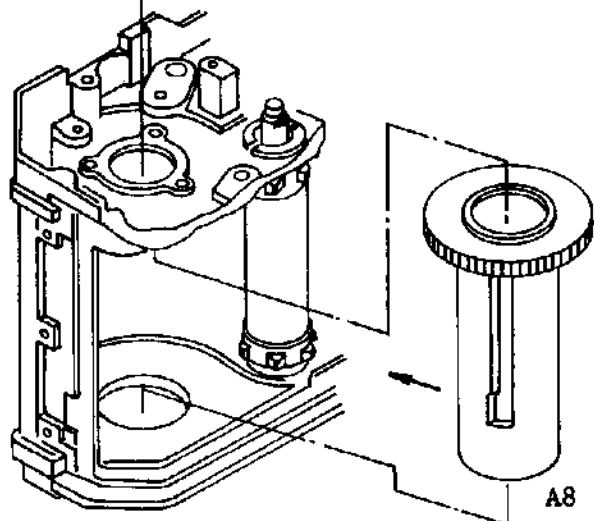
Baffle plate #79-1

[R] Hook the one end of Pendulum spring #538A to the baffle plate, with the plate pushed to Shock absorb rubber A#64.

⊕ #825 x 3

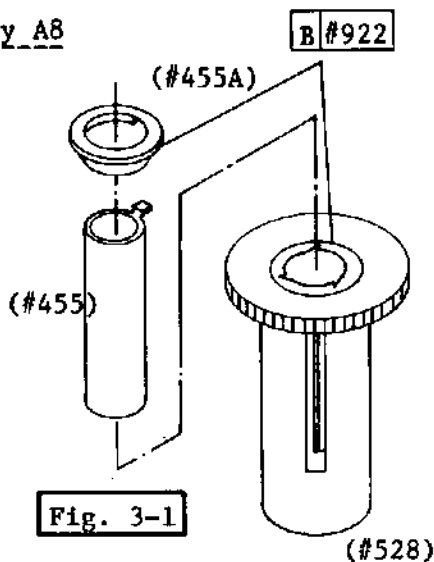


[Fig. 2-1]

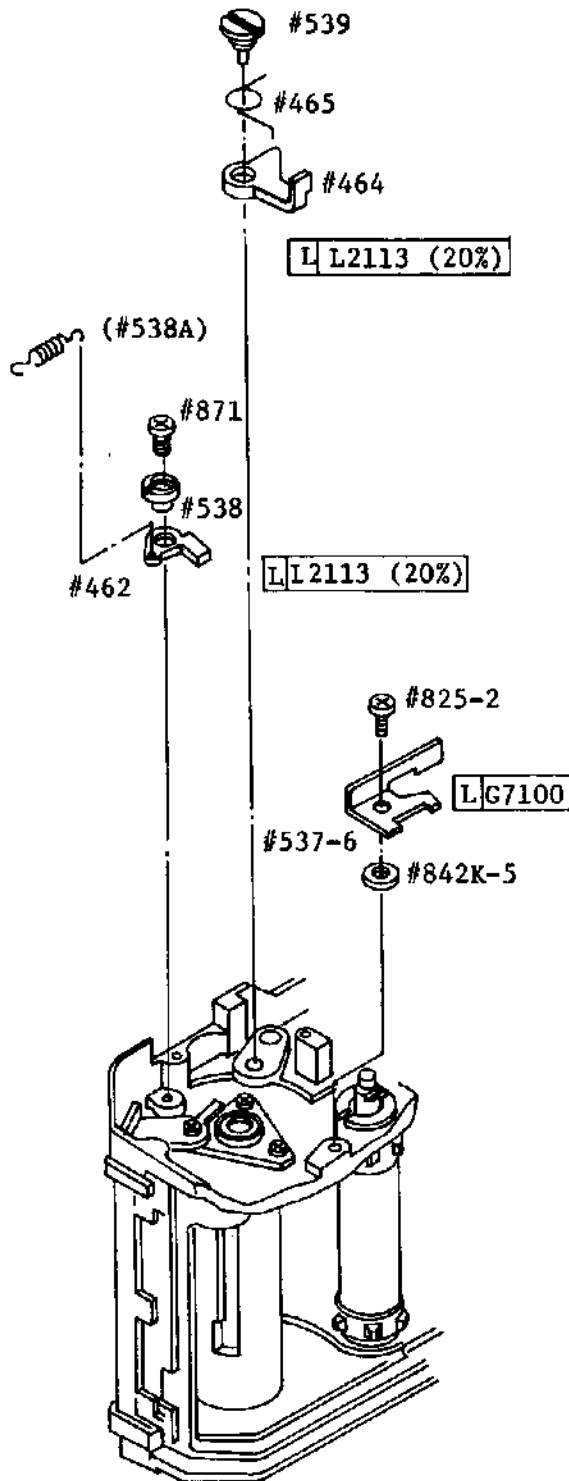


[R] **[Fig. 3-1]**

Assembly A8



[Fig. 3-1]

3-2 Lock lever installation

Lock lever #464
 ↓
 Lock lever spring #465
 ↓
 Lock lever axle #539

R After installation of the lock lever, hook lock lever spring #465 to the lock lever.

3-3 Pendulum installation

Pendulum #462
 ↓
 Pendulum eccentric axle #538
 ↓
 Screw #871
 ↓
 Pendulum spring #538A

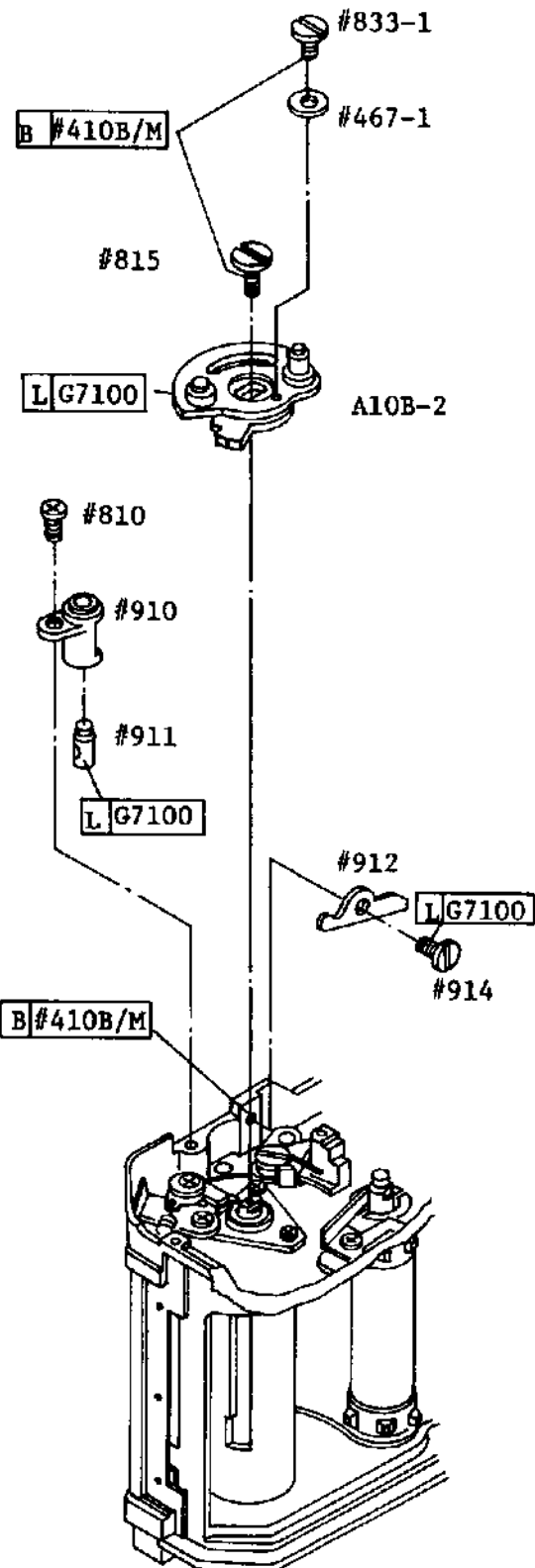
R After installation of the pendulum, hook the other end of spring #538A to the pendulum.

C Check the pendulum for smooth movement.

N Put the pendulum to the drawn-back portion with use of the eccentricity.

3-4 AR lever installation

AR lever #537-6
 ↓
 Washer #842k-5
 ↓
 Screw #825-5

3-5 Set cam installation

Setcam A10B-2

[R] Wash Setcam A10B-2 to remove grease.

[N] At installation of the setcam, use Tool to turn Spool shaft A9 one turn clockwise.

Film-advance shaft screw (left-handed) #815-5

[N] #815-5 has a left-thread.

Collar #467-1, Setscrew #833-1

[N] #833-1 has a left-thread.

3-6 MD shaft bearing installation

MD shaft bearing #910

[R] Put MD shaft #911 into MD shaft bearing #910.

[N] Bottom plate D-1 shows the guidance for installing position of #910.

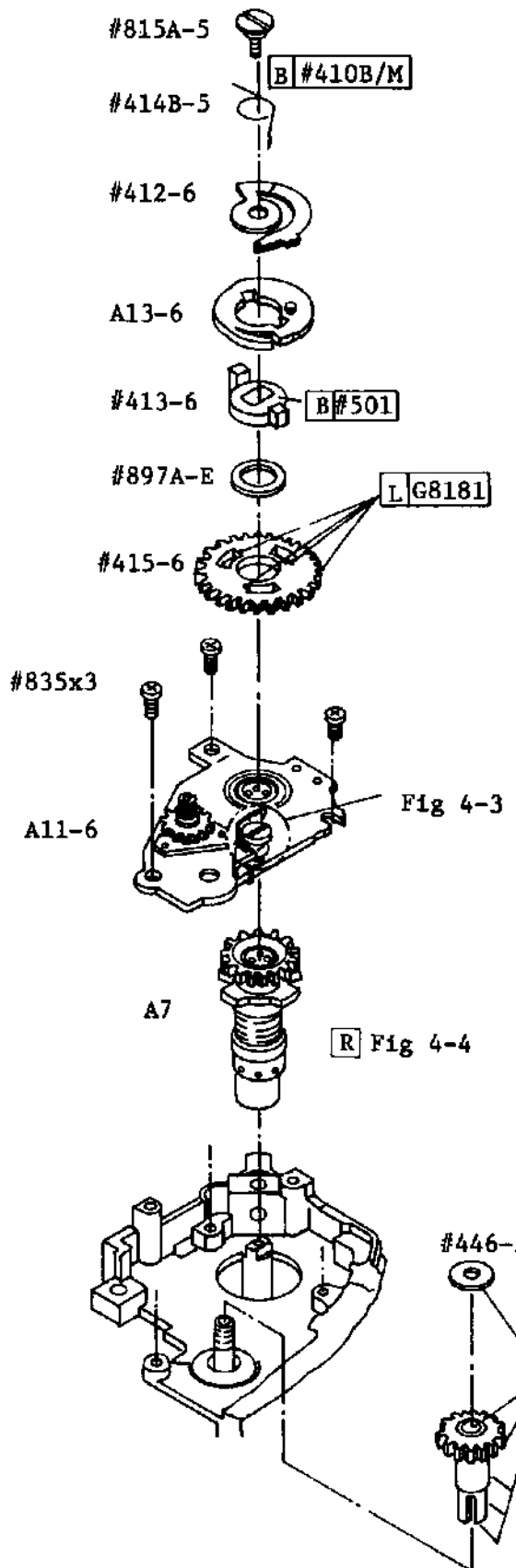
Screw #810

3-7 MD see-saw lever

MD see-saw lever #912

[N] Install #912 into the slot of #911.

MD see-saw lever axle #914

4-1 Spool top gear/lower bracket/wind-up gear installation

Spool top gear A7

R Rotating spool, let Friction plate #456-1 drop into inside groove of spool.

Sprocket upper gear #431-6

Washer #446-5

N Rounded surface should be placed upside.

Lower bracket A11-6 ⊕ #835 x 3

N Rotating spool, install lower bracket A11-6 in the position of the most smooth rotation

Wind-up gear #415-6, Wind-up cam #413-6, Washer #897A-E

N Washers #897A-E of five different thickness are available (0.05, 0.1, 0.2, 0.3, 0.25mm)

N Counter-sunk hole (8φ) of #415-6 is to be placed upside.

N The installing position of Wind-up gear #415-6 and Wind-up cam #413-6 is referred to Page.76V-b, Fig. 4-2.

Cam A13-6

N Hook Spring #412-6 to Cam A13-6.

Spring #412-6

R Cement #412-6 onto #413-6

Film-advance shaftscrew #815A-5, Spring #414B-5

N Standard tightening torque of screw #815A-5 is 3kg-cm.

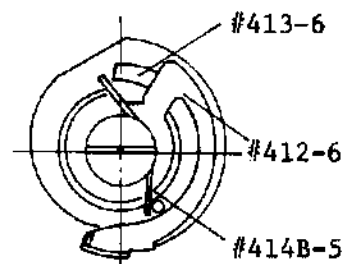


Fig. 4-1

- C** After tightening the screw, check the combination movement of Wind-up cam #413-6 and Spring #412-6.

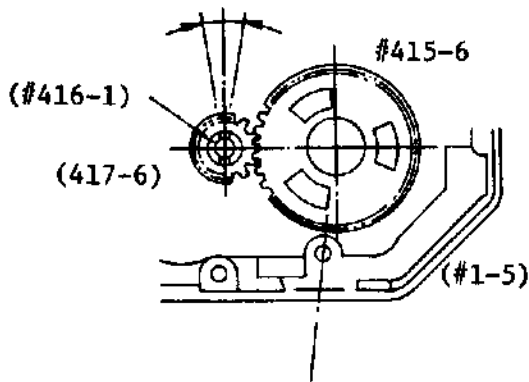


Fig. 4-2

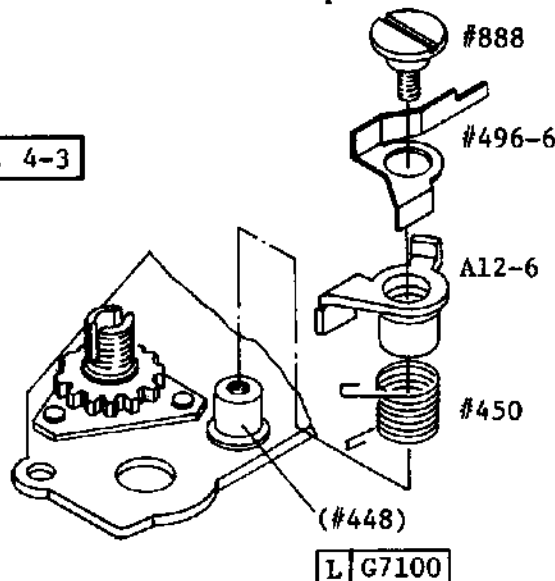
- R** Figure 4-1 shows the section where Spring #412 should be cemented on Wind-up cam #413-6.

Wind-up gear positioning

When one of the fan-shaped openings of Wind-up gear #415-6 is aligned with the center of screwhole for #441-6, the slot of #416-1 & #417-6 should locate toward the body line at a right angle.

Positioning allowance is within a one full portion of the slot #416-1.

Fig. 4-3



A7 disassembly

- R** Standard friction of spool : 125-157gcm
A For adjustment, loosen three Setscrews #824 to use the vertical movement of Spool top gear nut #421.

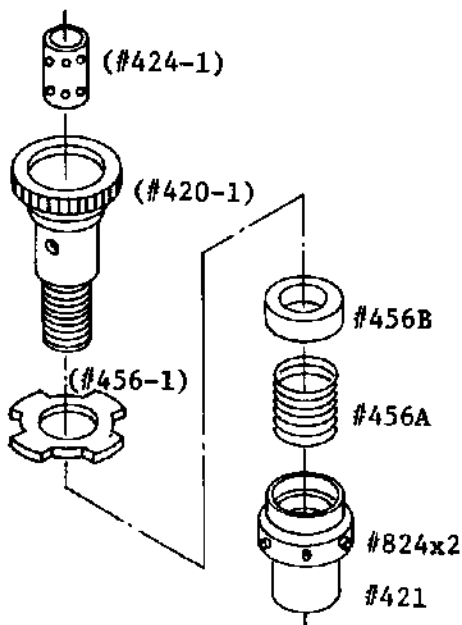
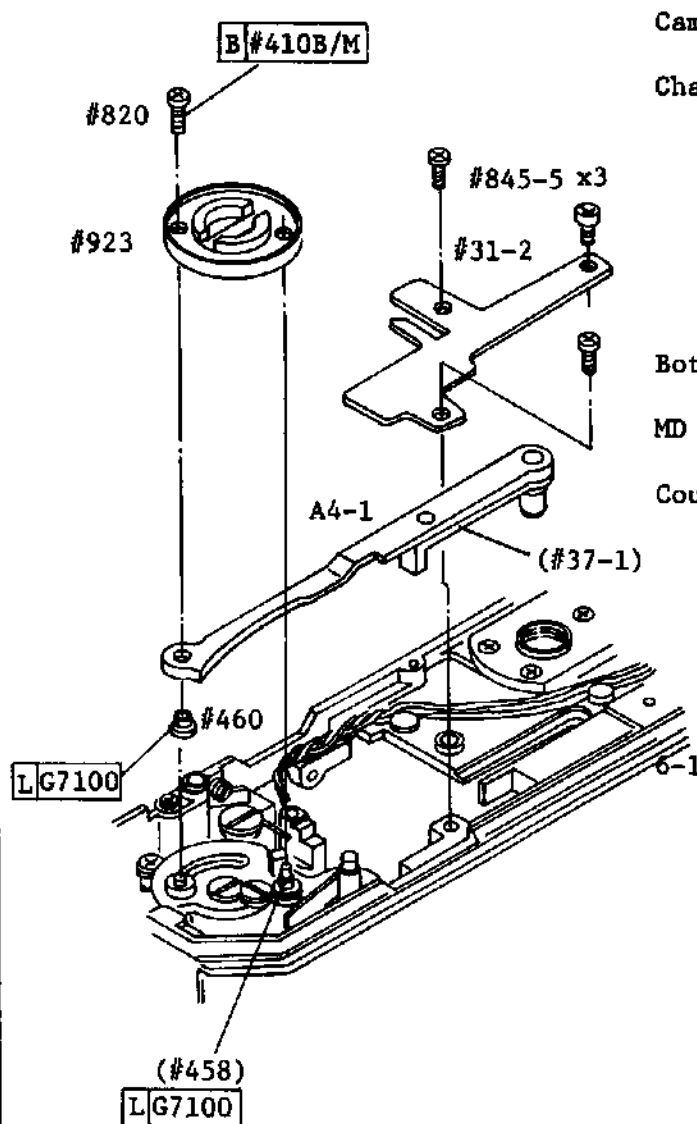


Fig. 4-4

5-1 Shutter charge lever/MD coupling installation



Cam collar #460

Charge lever A4

[N] Holding Cam collar #460 into the hole of charge lever A4, place shutter charge claw #37-1 to be coupled with Shutter charge pin #22 in the movement.

Bottom retaining plate #31-2 ⊕ #845 x 3

MD coupling #923

Coupling screw ⊕ #820

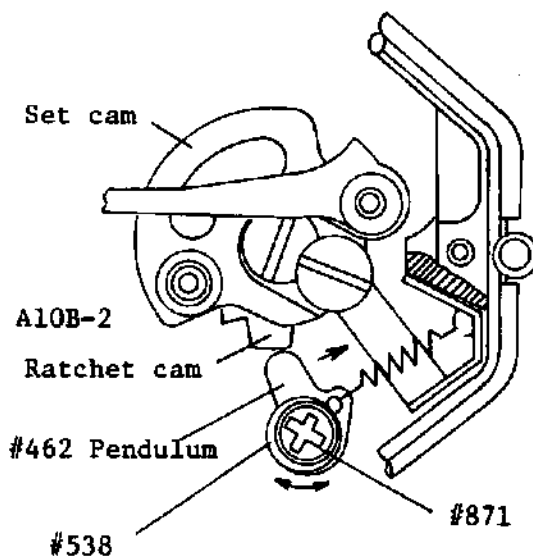
[C] Make sure that shutter is charged with the gentle stroke of film-advance lever and that the set cam returns to its rest position after the shutter cocking operation

Ratchet cam/pendulum adjustments

Relative position of Pendulum #462 to Sprocket stopper A12

At the last stage of the film-advance operation, the pendulum disengages from Ratchet cam #530 to trip Set cam A10B-2. From the timing of the disengagement, the film-advance lever stroke can reach the sprocket stopper A12 by 0mm-0.2mm movement. The eccentricity of Pendulum eccentric axle #538 makes adjustments.

[C] Check the proper shutter cocking and film-advance repeatedly by stocking the film-advance lever rapidly, slowly, strongly or gently.



5-2 Blank-shot preventing lever installation

Blank-shot preventing lever #26-2

Blank-shot preventing spring #97

[R] Hook the two holding arms
(marked *) #97 to #26-2.

[N] Lubricating oil should be applied
at minimum for preventing its
exudation to the electromagnet
of shutter.

Blank-shot preventing axle #98, ⊕ #915 x 1

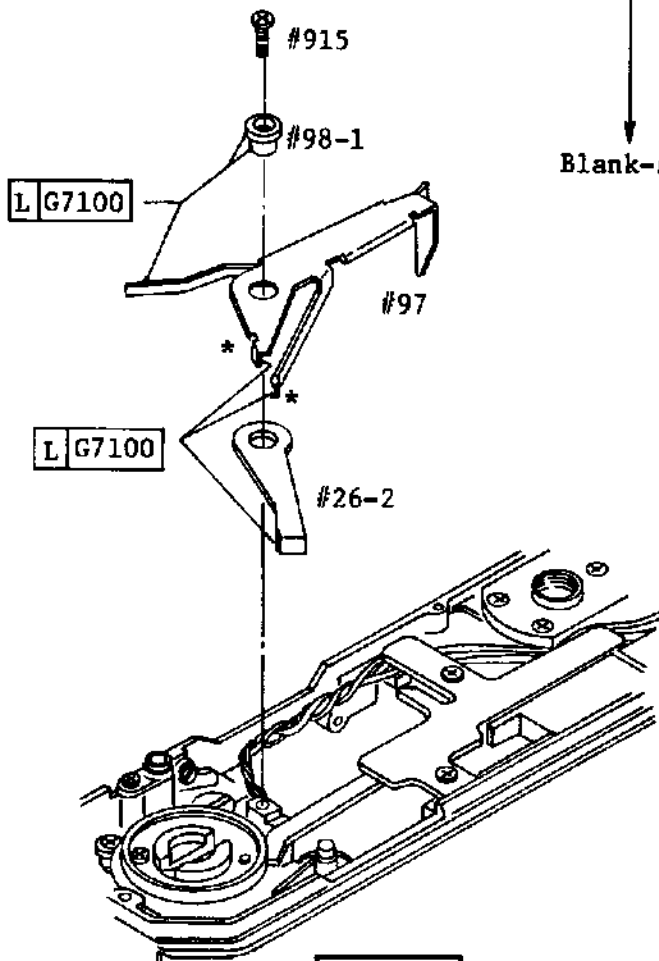
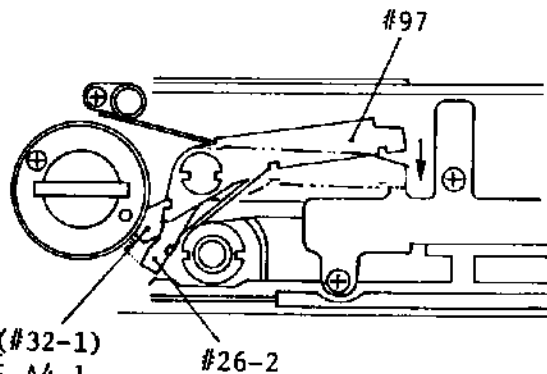


Fig. 5-1

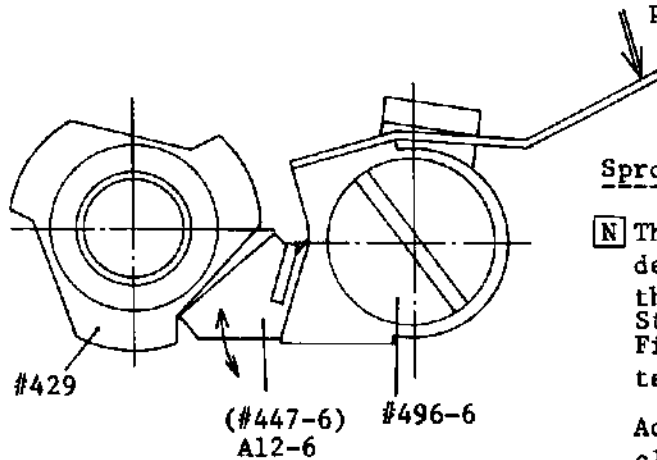


Blank-shot preventing lever adjustment (#32-1)
A4-1

[C] Make sure that when the spring moves to the direction of arrow, the lever will follow the movement properly and that it returns to the rest position.

[C] First hold the blank-shot preventing lever at the position of the dotted line, after the film-advance lever is stroked to the limit. Then, return the film-advance lever to the stand-off position. In this movement, the blank-shot preventing lever will always couple to Shutter charge lever #32-1, which functions as the blank-shot preventor.

7-1 Sprocket stopper/sprocket positioning (After Upper bracket installation procedure 9-1)

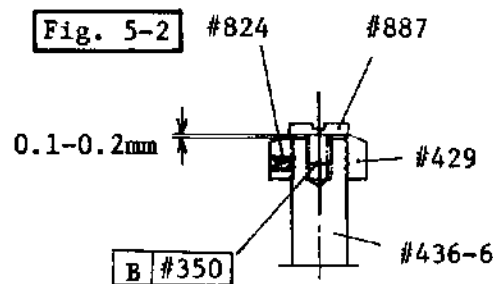


Sprocket stopper positioning

N The position of sprocket stopper is determined by the amount of play at the top of each sprocket tooth. Standard play: within 0.8mm. Figure shows that the play of sprocket teeth is measured by Tool J-18064-1.

Adjustments can be made by changing the clearance between Sprocket stopper cam #429 and Sprocket stopper #447-6.

First, use the film-advance lever to place the sprocket stopper cam close against the sprocket stopper. Next, unscrew Sprocket screw #887 (left-threaded), and loosen Setscrews #824 to turn the sprocket stopper cam for adjustments. Use care to maintain 0.1 - 0.2mm clearance between the sprocket stopper cam and Sprocket shaft #434-6 during adjustments. The measurement should be repeated

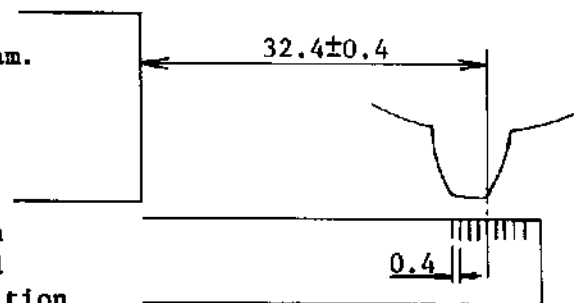


three times to check the proper amount of play at each engagement position of the sprocket stopper cam.

Sprocket positioning

A When the film-advance lever is stroked holding the sprocket with a slight finger touching, the end of the sprocket teeth should position against the calibration of J18064-1 as shown in Figure 5-3.

Adjustments can be made by turning Sprocket stopper cam #429, with Setscrews #824 loosened.



(J18064-1)

Fig. 5-3

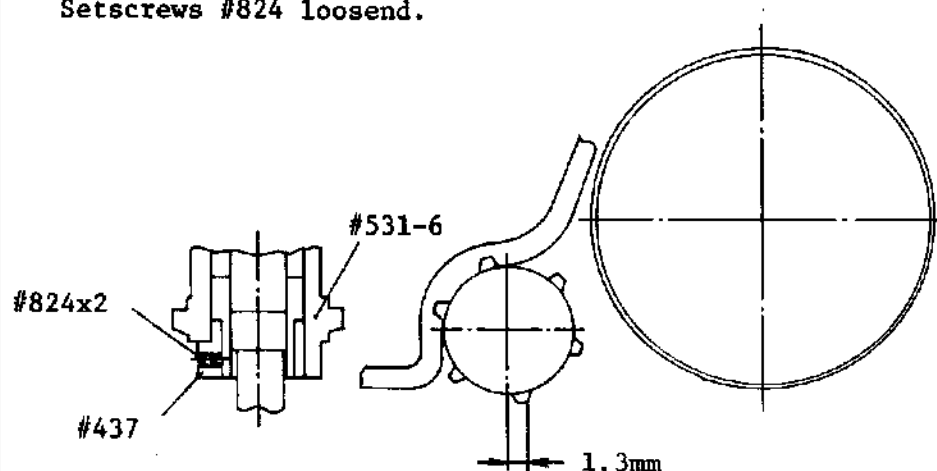
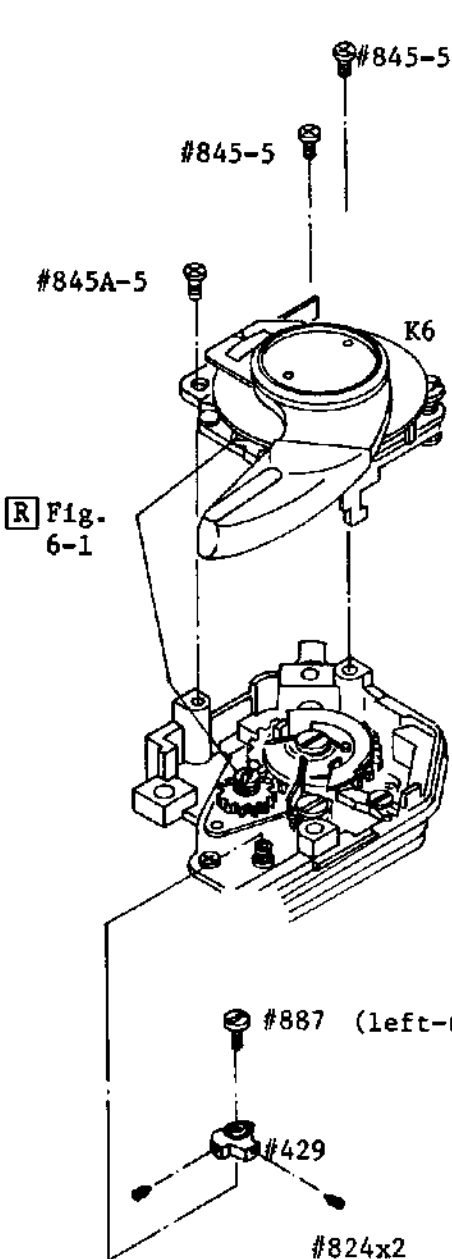


Fig. 5-4

9-1 Upper bracket installation



Body (#1-5)

Upper bracket K-6

N When installing Upper bracket K-6, bring Cam A13-6 in engagement with Advance gear A#415-6.

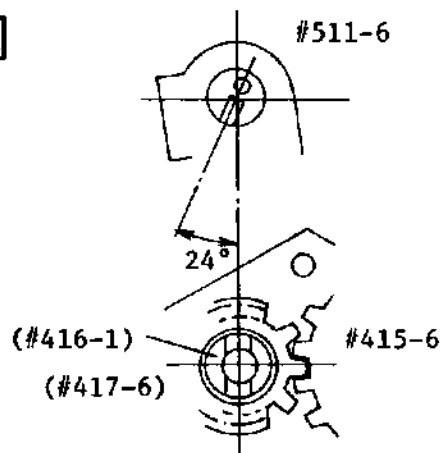
R
N The relative position between Advance claw lever #511-6 and Idle gear B #417-6 should be as depicted in Figure 6-1.

Screw #845A-5

Screw #845-5 x 2

N Screw #845-5 in place, aligning the cutout of Frame-counter dial #502 with the screw hole.

Fig. 6-1



Advance claw lever engagement

9-2 Sprocket stopper cam installation

Sprocket stopper cam #429

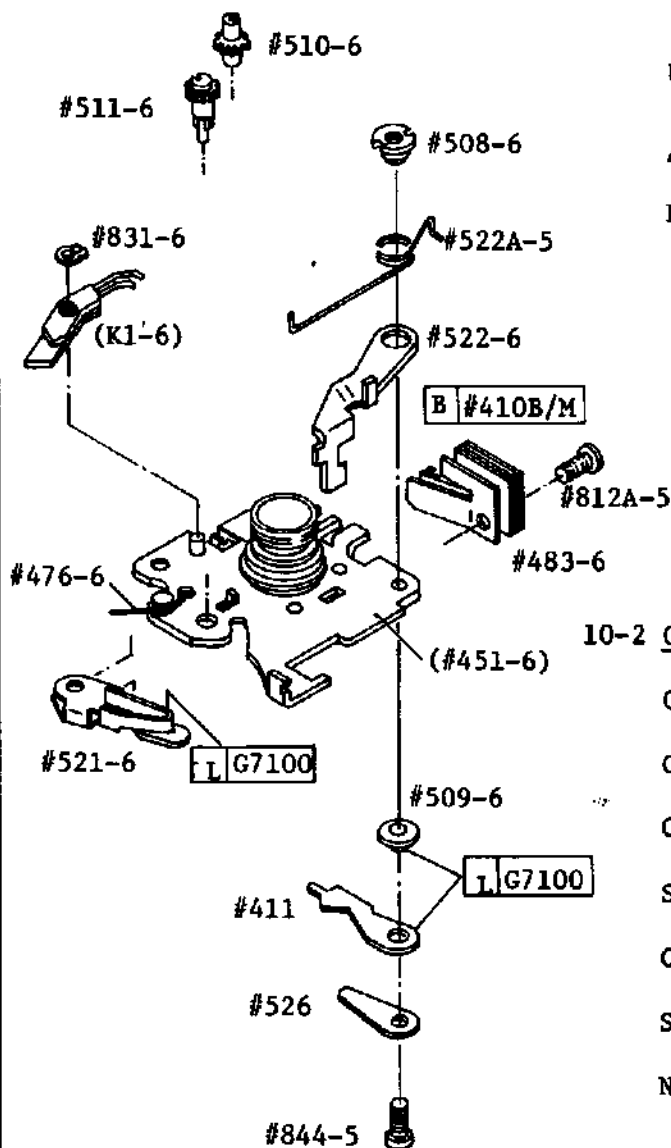
N Temporarily tighten Setscrews #824 for adjustments in the next step.

N Screw Sprocket stopper cam #429 in place to go as high as Sprocket shaft #431-6.

Sprocket screw (left-threaded) #887

N Sprocket stopper cam positioning should be referred to Page 78V.

10-1 Upper bracket component installation



Upper bracket (#451-1)

↓
Advance claw gear #511-6

↓
Resetting spring #521-6

R After installing Advance claw #510-6, fix Resetting spring #521-6 in place.

R
N The cutout of the gear shaft #510-6 should face the spring in the shutter-cocked condition for proper operation of the frame counter. See Figure 7-1.

10-2 Counter reset lever

Click lever axle #509-6

↓
Click lever #411

↓
Click lever stopper #526

↓
Screw #844-6

↓
Counter reset lever #522-6

↓
Spring #522A-5

↓
Nut #508-6

N Hook Spring #522A-5 to Resetting spring #521-6. (Fig. 8-1)

10-3 Click lever spring

Click lever spring #483-6 x 5

↓
Screw #812-6

Fig. 7-1 Advance claw gear engagement

10-4 Switch

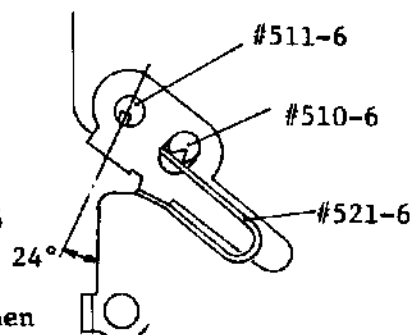
Spring #476-6

↓
Switch K1-6

R For proper contact of Switch K1-6 use a thinnest metal plate (0.08t) to provide a clearance between K1-6 and G-ring #831-6, when fixing the G-ring.

N Do not use the G-ring once removed.

R Hook each end of Spring #476-6 to the cutout of the upper bracket and the switch.



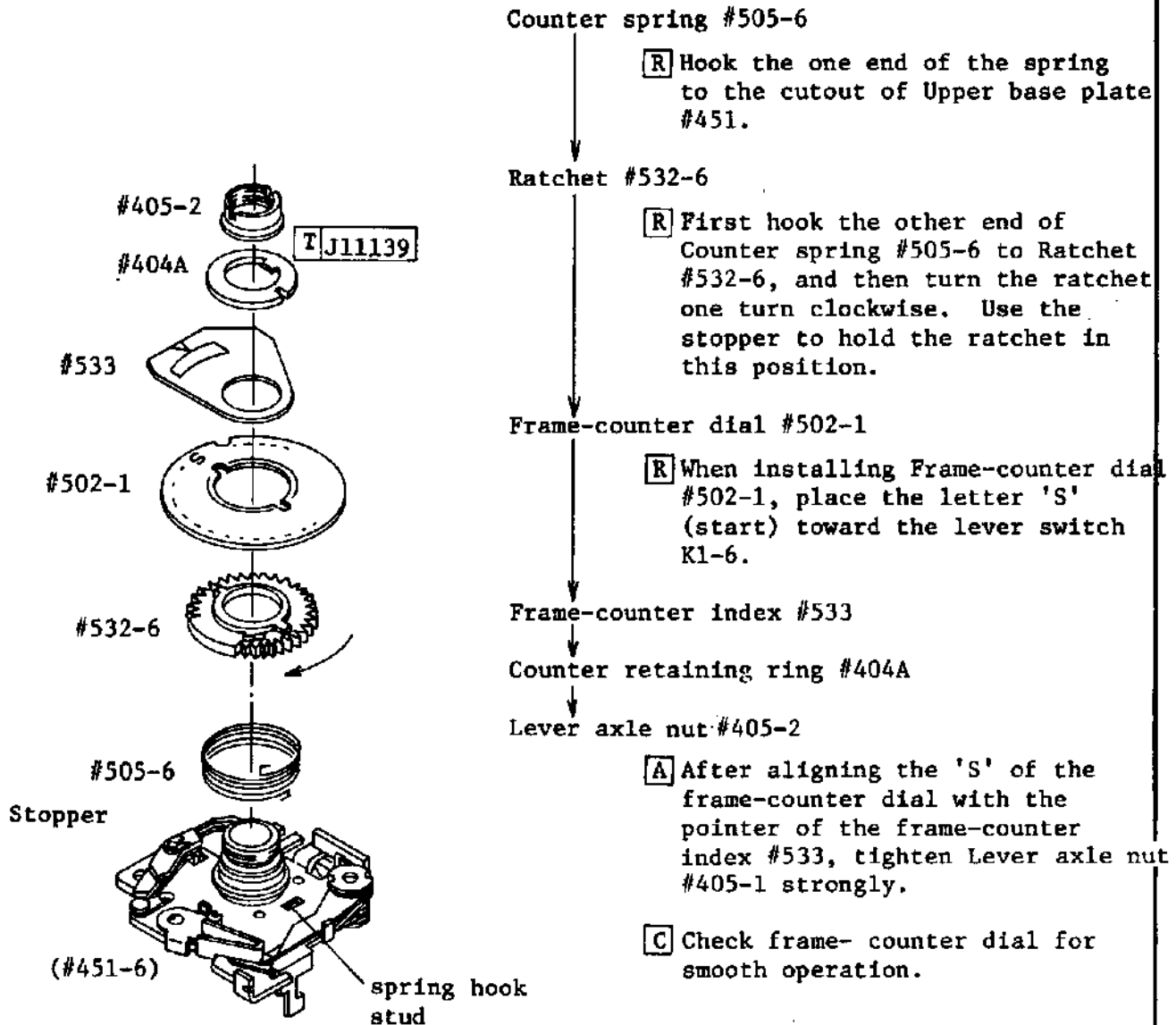
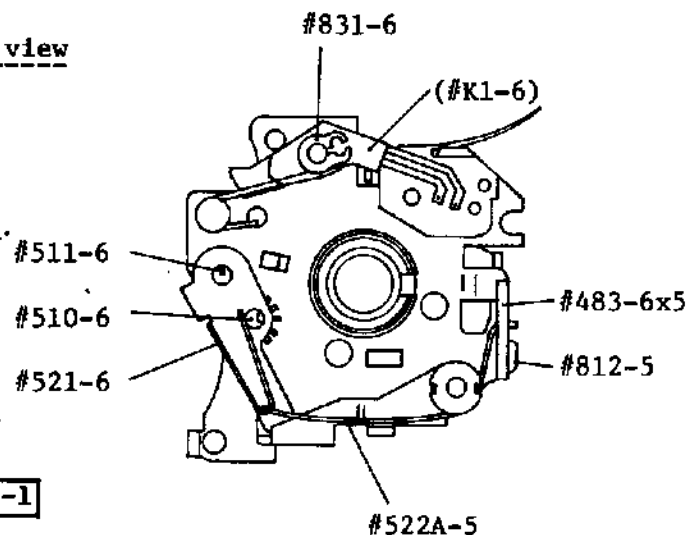
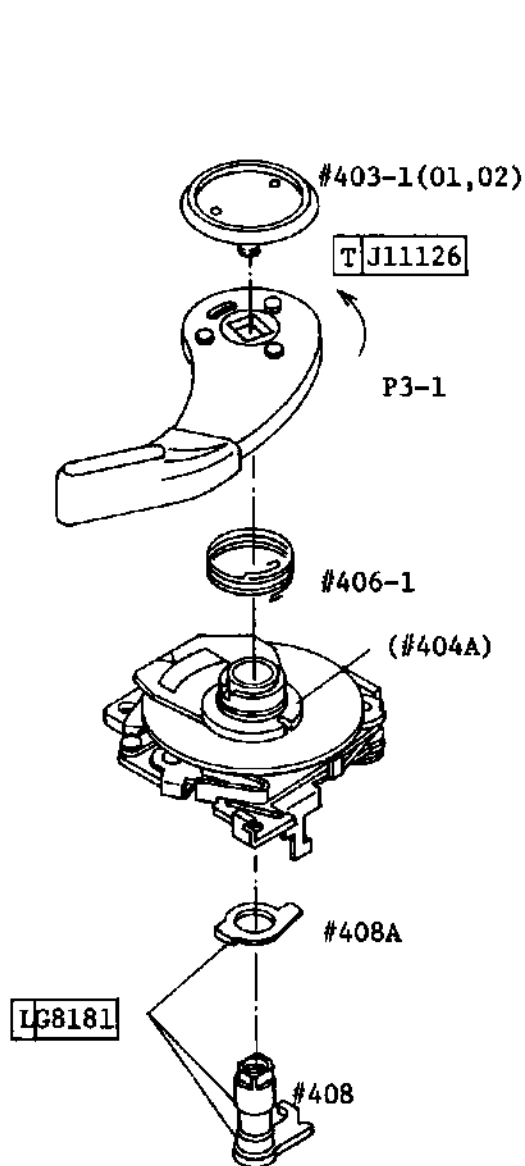
10-5 Frame-counter dialUpper bracket component; top view

Fig. 8-1

11-1 Film-advance lever installation (temporary)

Sprocket stopper release plate #408A

Film-advance shaft #408

Film-advance lever retaining spring #406-1

- [R] Hook one end of #406-1 to the cutout of Film-advance lever bush #404A-1.

Film-advance lever P3-1

- [R] Hook the other end of #406-1 to the cutout of Film-advance lever P3-1, and then turn it one turn counter clockwise.

Wind-up lever screw #403-1

- [C] Check Film-advance lever P3-1 for smooth movement.

- [C] Standard torque to pull out the lever : 1-2 kg cm
Standard play in a vertical direction : within 0.13mm

- [N] The figure 9-1 shows the rest position of film-advance lever and the engagement between #408 and #411 at that time.

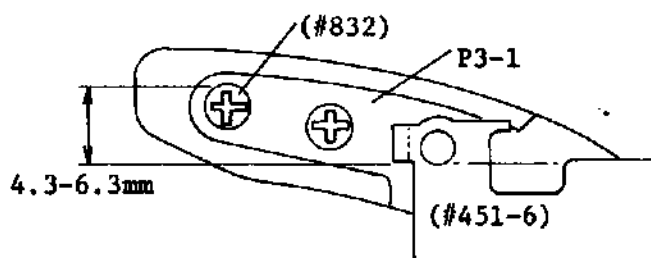
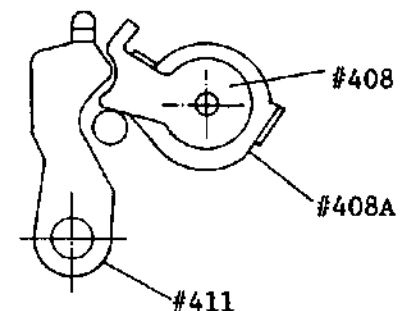
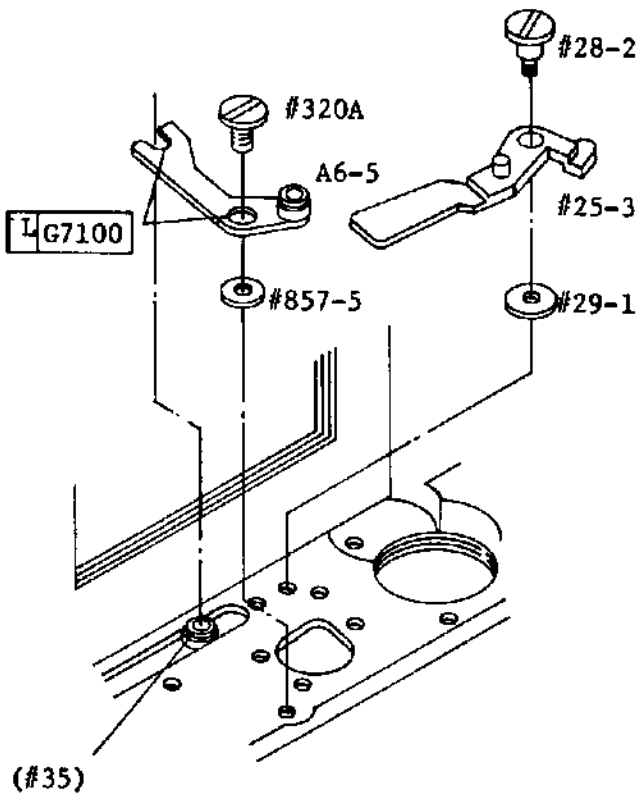
Film-advance lever rest position

Fig. 9-1



12-1 Charge lever/MD switch coupling lever/Battery chamber Installation



Body (#1-5)

↓
Charge lever washer #857-5

↓
Charge lever A6-5

ⓘ Catch the shutter charge lever with the fork of Charge lever A6-5.

↓
Charge lever axle #320A

↓
Blank shot check lever collar #29-1

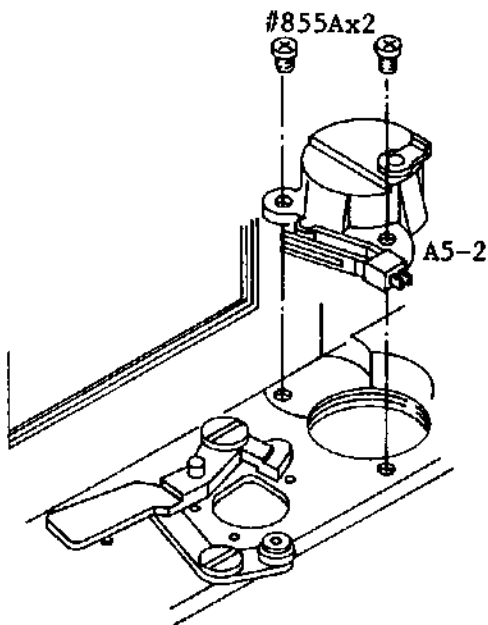
↓
MD switch coupling lever #25-3

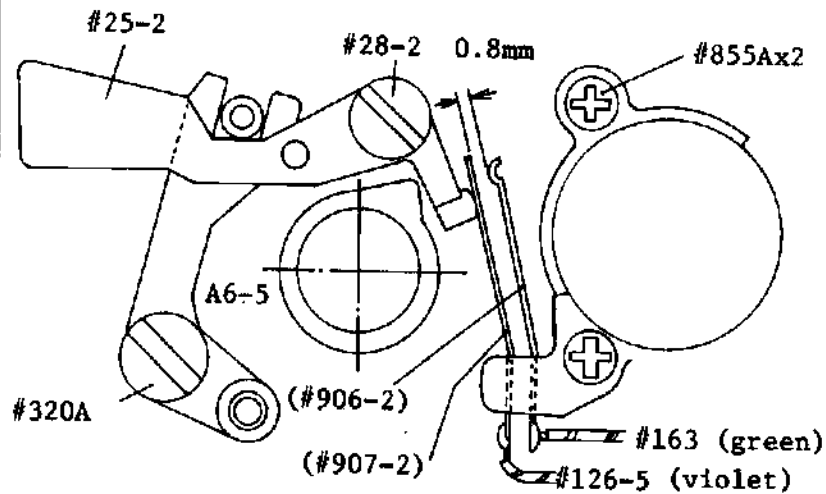
↓
Signal lever axle #28-2

Body (#1-5)

↓
Battery chamber A5-2 ⊕ #855A x 2

ⓘ Adjustments of MD switch coupling lever can be referred to Page 82V

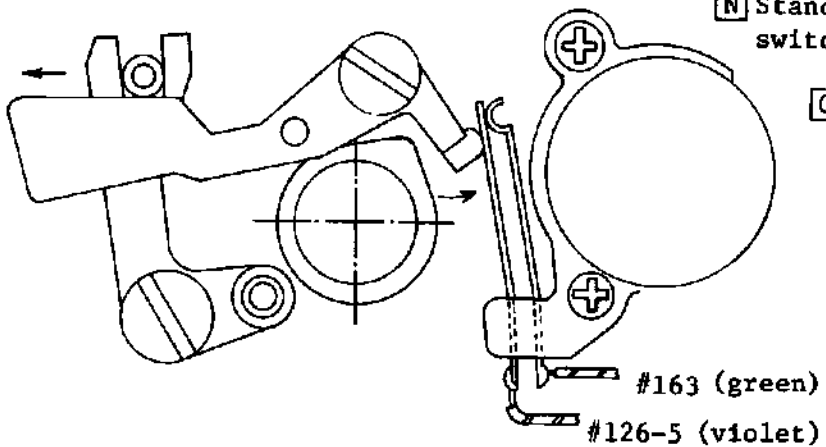


13-1 Charge-lever / MD wind-up switch installation

At the finish of shutter cocking cycle

- C** A slight interval approx. 0.8mm should be maintained between Switch contact A #906-2 and contact B #907-2 in the shutter-cocked condition.
- A** Adjustments can be made by bending one/each of them.

Halfway in the shutter cocking cycle

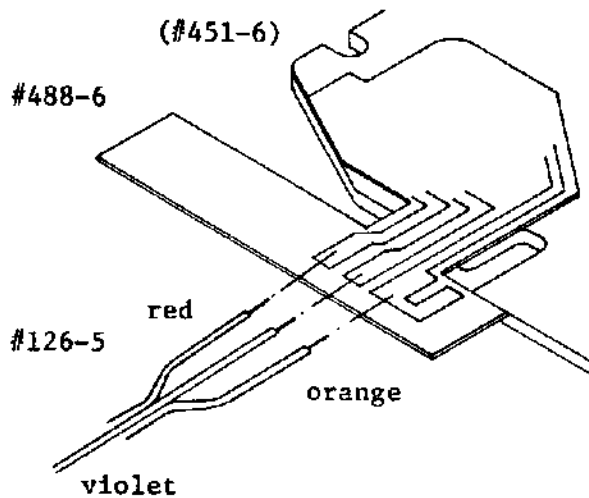


N Standard contact pressure of the switch blades = about 50 - 60g.

- C** The switch remains closed during the shutter cocking cycle.

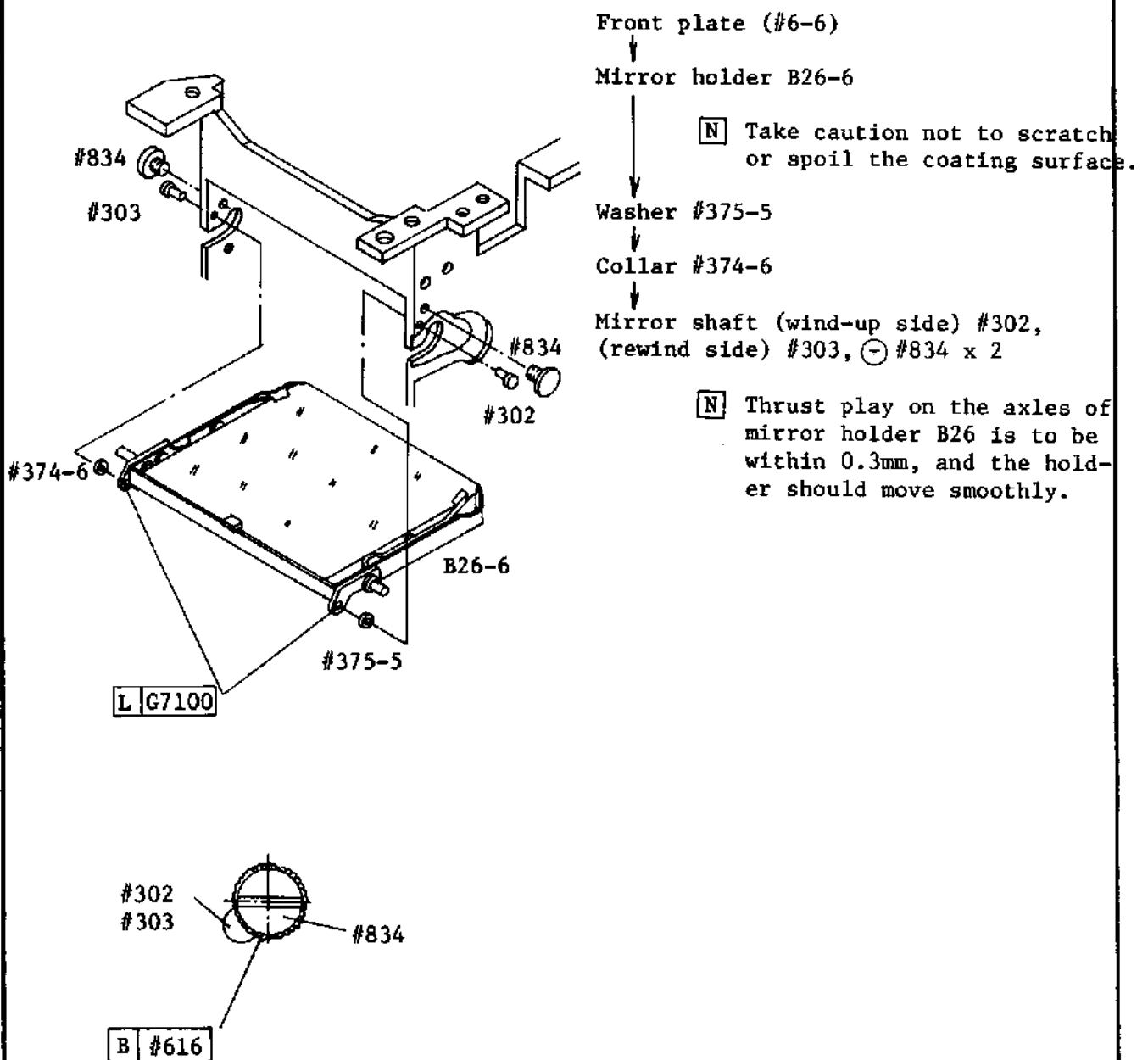
13-2 Soldering wires to Switch K1-6

Switch printed circuit seat #488-6

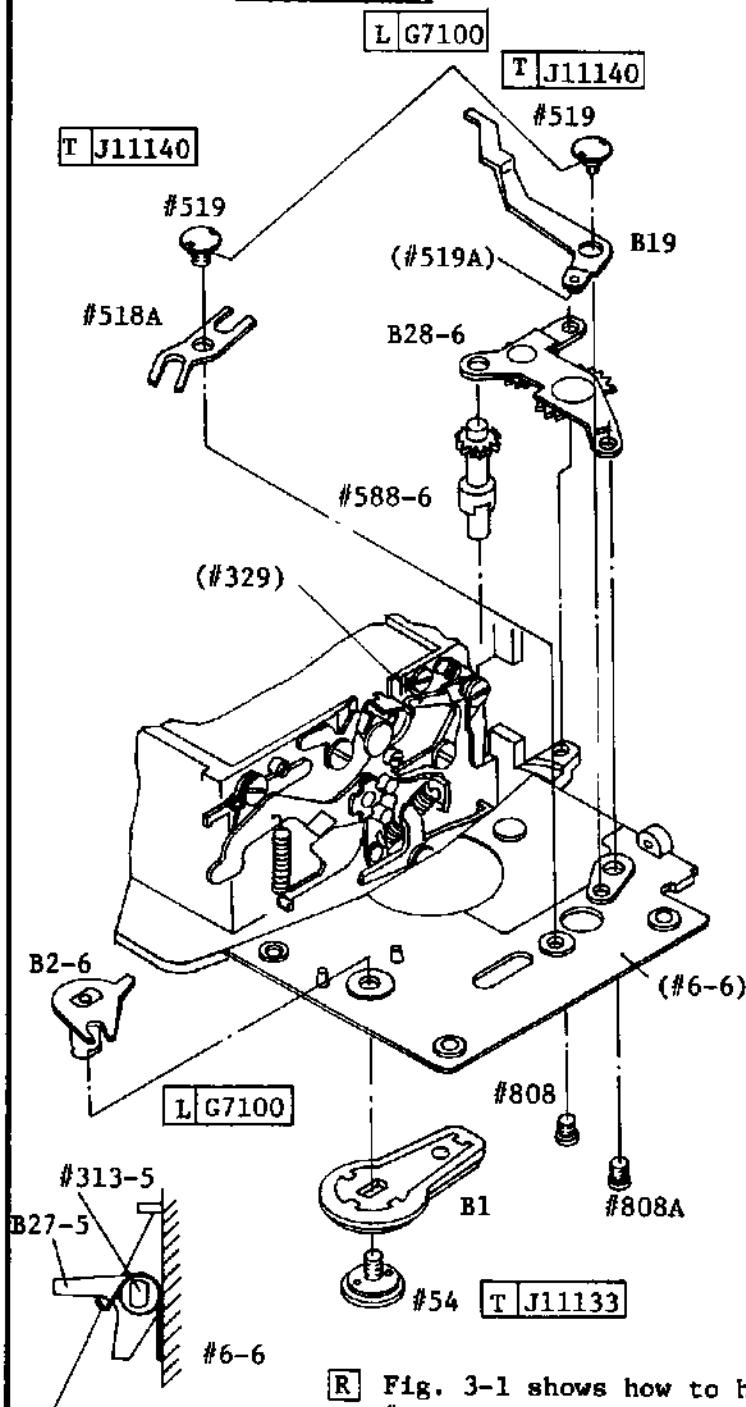
Wire #126-5 Solder the wires as shown in the figure. Check the solder joints, referring to the table.

Film-advance lever	Violet wire/Switch #451-6	Red wire/Orange wire
at the rest position	on	off
at the stand-off position	off	on

 The film-advance lever should not catch at the switch blade in the movement.

15-1 Mirror / mirror holder / stop-down lever unit installation

15-2 Idle gear, Release lever, Self-timer lever and Stop-down lever installation



Front plate #6-6

↓
Gear #588-6

↓
Idle gear base plate B28-6
⊕#808 ⊕#808A

↓
Release lever Fork #518A
(Watch out for the direction)

↓
Release lever axle #519

↓
Release lever B19

↓
Release lever axle #519

R Engage Pin #519A with #518A, and place B19 to #329 from the direction of arrow.

C Check B19 for vertical play of the lever end : less than 0.6mm

Self-timer coupling lever B2-6

↓
Self-timer lever B1

↓
Self-timer lever screw #54

C Make sure of smooth movement of B1. Check B1 for vertical play of the lever end : less than 0.15mm

Stop-down lever spring #313-5,
Stop-down coupling lever B27-5

R Fig. 3-1 shows how to hook #313-5 in place.

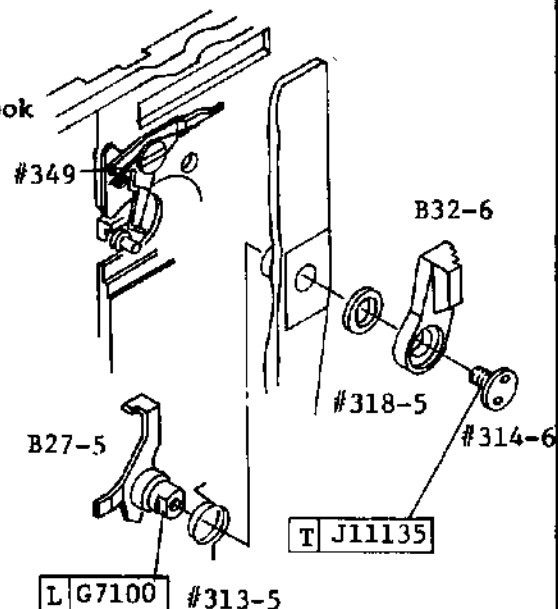
Fig. 3-1 Washer #318-5, Stop-down lever B32-6

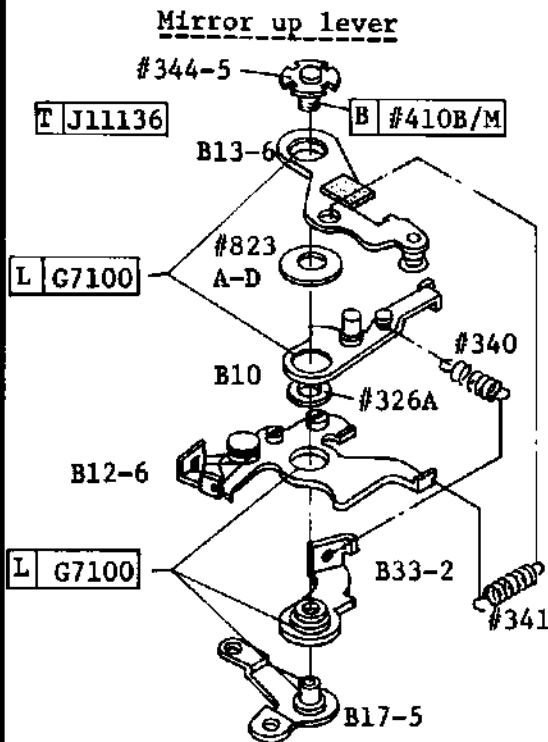
R Put B32-6 on to B27-5

↓
Stop-down lever screw #314-6

C Make sure of the smooth movement and the spring-loaded return of #B32-6

Check the lever for vertical play : less than 0.2mm



16-1 Mirror-up lever / mirror actuating system installation

Mirror lever base plate B17-5

Spring stud #376-1 (B33-2)

Mirror-up lever B12-6

Stop-down coupling lever B10,
Washer #823A-D

N Replace Washer #823 to adjust the
excessive play of the levers.
(t=0.05, 0.1, 0.15, 0.2)

Mirror-down lever B13-6

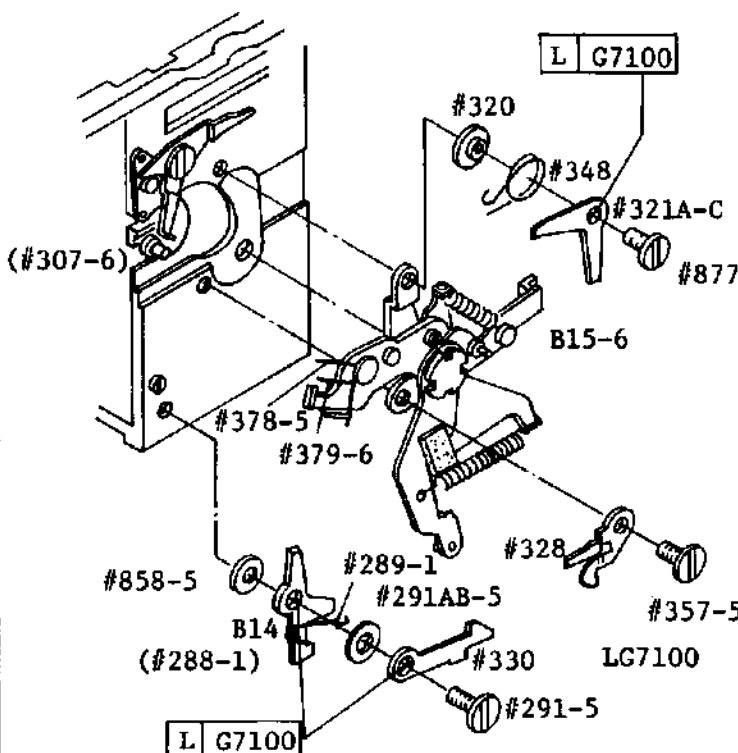
Mirror-down lever screw A #344-5

Stop-down lever spring #340, mirror-up
spring #341

C Make sure of the smooth movement of
each lever.

Fig. 4-1

Mirror actuating system



Front plate (#6-6)

Subassemblies B10, B12-6, B13-6,
B17-5

Signal lever #328 (357-5 x 1)

C Make sure of the smooth
movement of lever.

Shutter release lever #321A - C,
Collar #320, Spring #348,
Axle #877

C Make sure of the smooth
movement of lever.

Mirror-up stop lever #329, Spring
#349, Axle #331-5, Washer #854

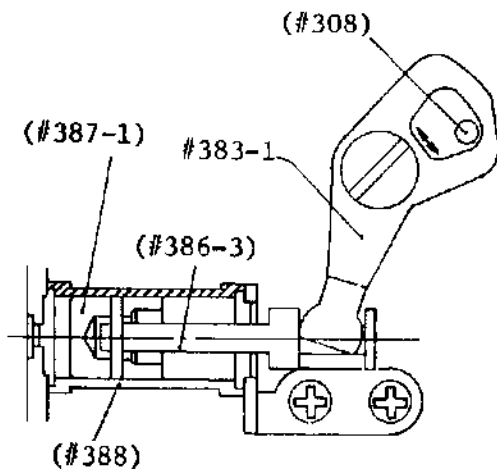
Mirror-down signal lever B14

Down lever stopper #878A(B)-5

Washer #858-5, Mirror-down latch
lever #330, Latch lever axle
#291 AB-5

17-1 Air damper installationAir damper mechanism

The mechanism remains exactly the same as earlier.



Front plate #6-6
↓
Air damper B20-1

- [R] Insert #386-3 into #387-1 through #397-1 and #393-2. And put #850-1 into the access hole of #387-1, aligning the hole with that of #386-3.
Next put the sub-assembly into #388; that is Air damper B20-1.

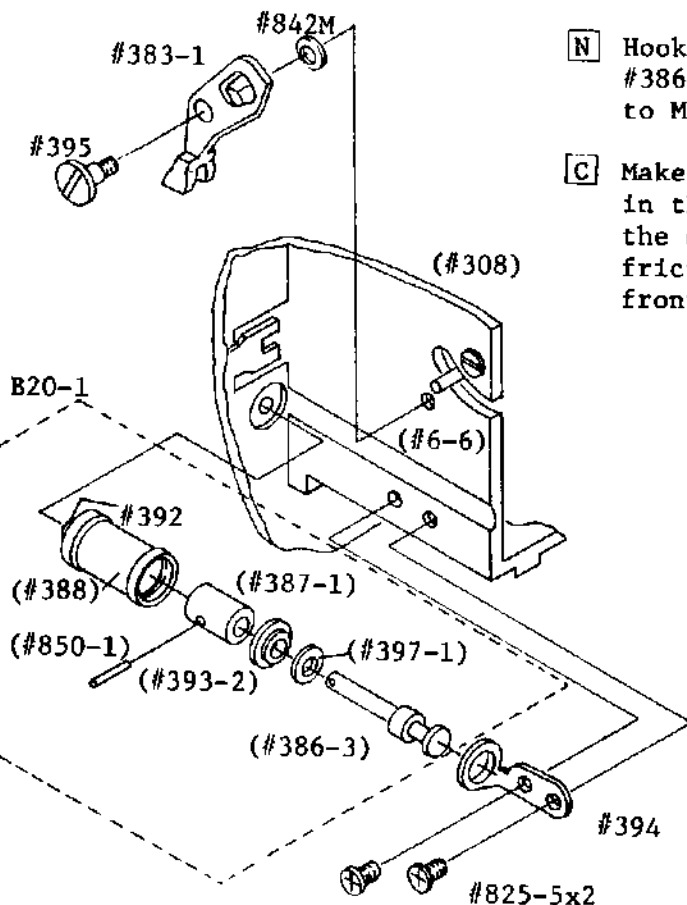
Air damper lever screw #394 ⊕ #825-5 x 2
(used for centering)

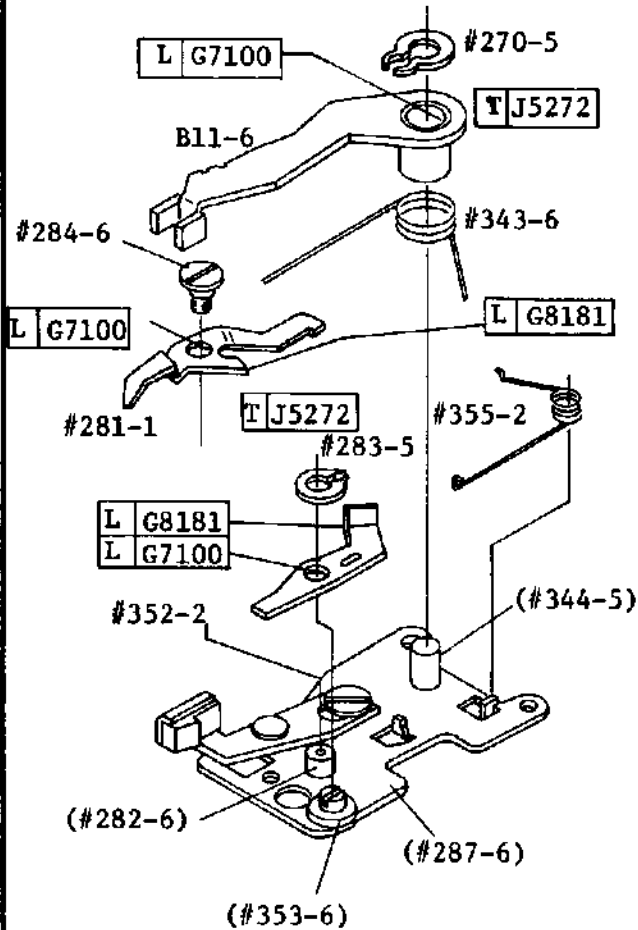
- [R] Place B20-1 along the depression of #6-6

Washer #842M, ⊖ #395
Air damper lever #383-1

- [N] Hook the fork of #383-1 to the neck of #386-3, and the squared hole of #386-3 to Mirror holder pin #308.

- [C] Make sure of the smooth movement of damper in the mirror lifting / returning action--the damper should not have a catch or friction. Check it once more holding the front plate upside down.



18-1 Shutter brake subassembly installation

Base plate #287-6

MD take-up signal middle lever #352-2

- [R] Put #352-2 to MD take-up signal middle lever axle #353-6 and fix it with G-ring #283-5. Watch out for the direction of the G-ring installed as shown in Fig. 5-1.

Brake release lever #281-1

- [R] Screw #284-6 into #282-6 to fix #281-1 in place.

Brake lever retaining spring #355-2

- [N] Fig. 5-1 shows how to hook #355-2 in place

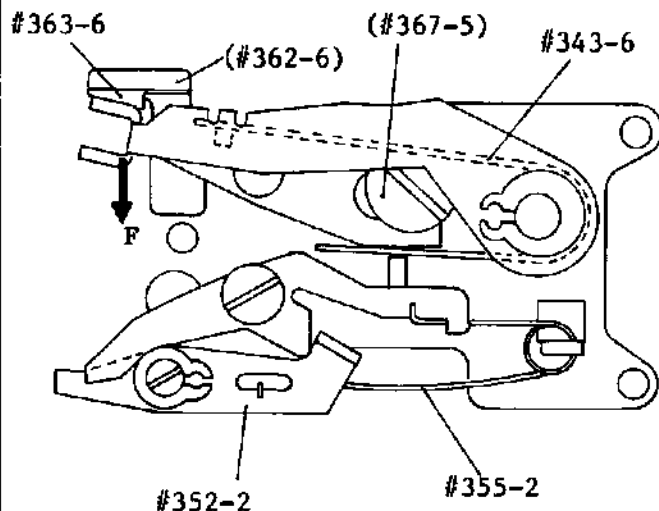
Mirror charge lever B11-6

- [R] Put B11-6 to Mirror holder screw #344 and fix it with G-ring #270-5.

- [N] Depress the ring as far as it will go, so that there is no vertical excessive play of B11-6

- [N] See Fig. 5-1.

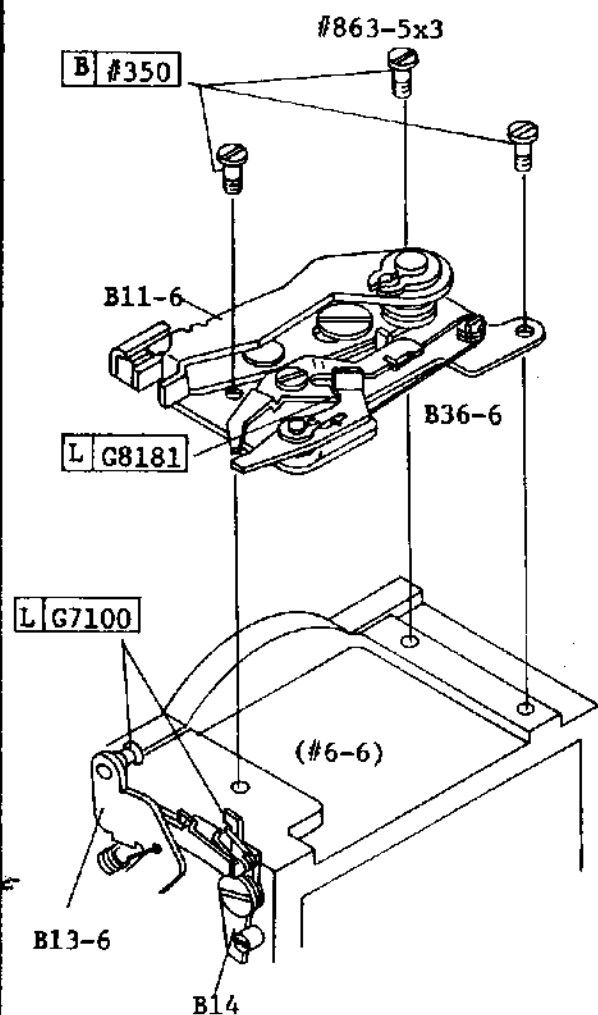
Check the torque of Mirror charge lever B11-6



- [C] Check the torque at that moment when B11-6 is separating from Shock absorber rubber #363-6 of Down lever adjuster B21. Use Torque gauge J5019 to pull the fork of B11-6 for measurements in the direction F.

Standard torque: 230 - 270g

Fig. 5-1

19-1 Shutter brake subassembly B36-6 installation

- N** Before installing B36-6 in place, engage MD take-up signal middle lever #352-2 with Brake release lever #281-1.
 ⊖ #863-5 x 3

Depress Mirror down lever B13-6 downward to couple it with the fork of B11-6.

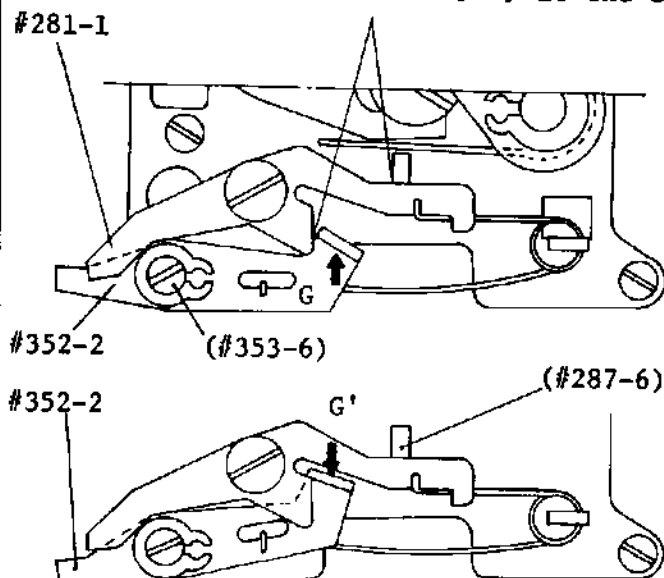
- A** After installation, disengage #352-2 from #281-1, and then use the eccentricity of #353-6 to adjust the position of #352-2.

#352-2 should be positioned in the condition that there is no clearance between #352-2 and #281-1, as well as between #281-1 and #287-6. See Fig. 6-1.

- C** Make sure of the smooth movement of mirror with B11-6 released.

Check the shutter brake for proper function, with B13-6 and #281-1 moved.

No excessive play at the engagement points



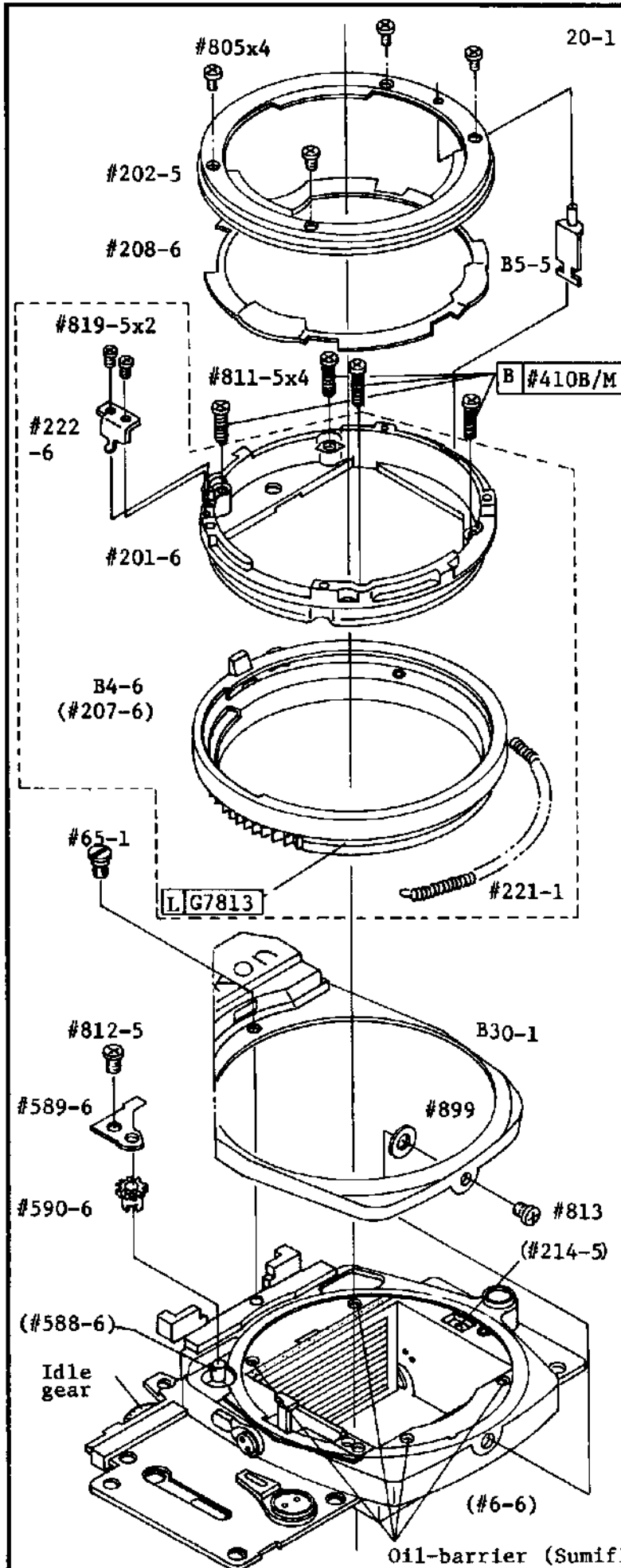
Standard engaging torque

G = 200 - 450g

disengaging

G' = more than 90g

Fig. 6-1



20-1 Bayonet ring / aperture
coupling ring installation

Front plate #6-6

Front pinion #590-6

Gear bearing #589-6 ⊕ #812-5

N Fix #589-6 using care to smooth movement of the idle gear.

Front cover B30-1

Screw (Black) #65-1

Front cover screw #813

Lens mount (surround with dotted line)

R The lens mount consists of B4-6 and #201-6

N Fix #222-6 along with the circumference #201-6

Page 90 shows B4-6 assembly.

Lens release lever B5-5

R Put B5-5 into the coupler of #214-5.

⊕ #811-5 x 4

Bayonet spring #208-6

Bayonet #202-5

⊕ #805 x 4

N Make sure of smooth movement of B5-5.

Fix torque : more than 3kg.cm

C See page 90.

N Do not catch #208-6 under #202-5.

Oil-barrier (Sumiflunon FP-81)

20-2 Aperture coupling ring B4-6 installation

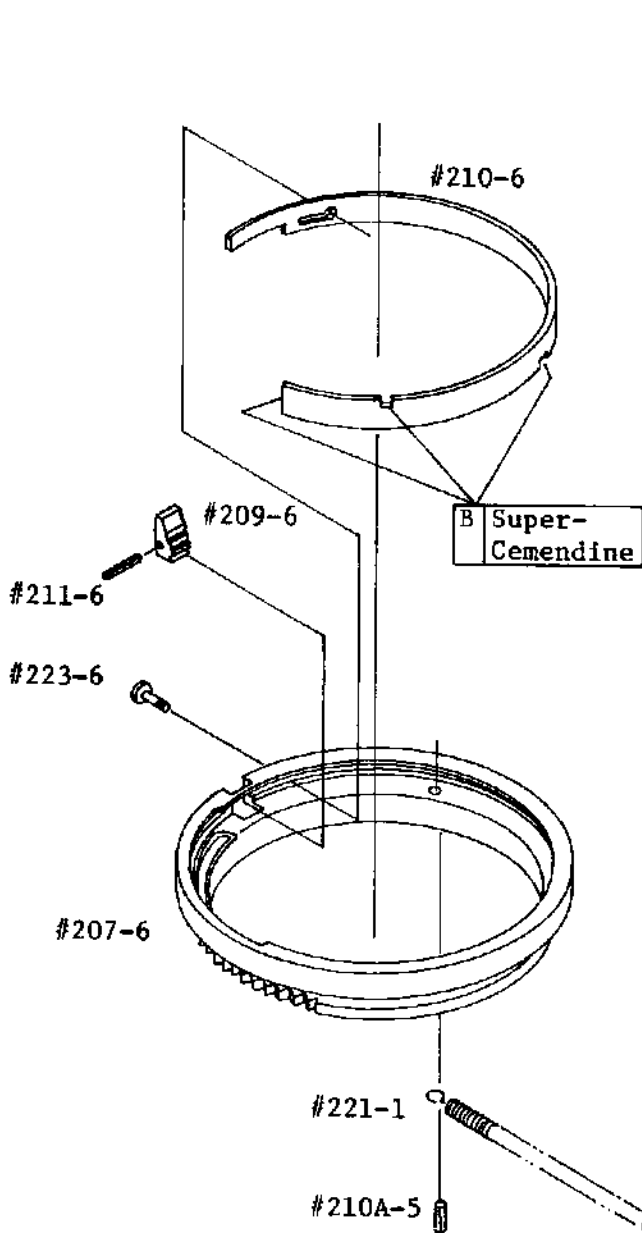


Fig. 7-1 Aperture coupling piece

Aperture coupling ring #207-6

Aperture coupling piece #209-6

- [R] Before installation, put Coupling piece shaft #211-6 into #209-6.
- [RN] Put #209-6 into the cutout of #207-6 to drop #211-6 in the slot of #207-6. See Fig. 7-1.
- [C] Check #209-6 for smooth movement

Coupling piece spring # 210-6

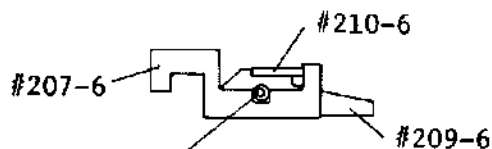
- [N] Do not deform #210-6. Watch out for the direction of fixing #210-6.

Coupling piece spring button #223-6

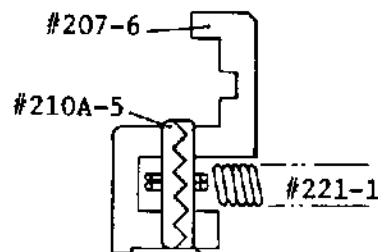
- [R] First insert #223-6 through the hole of #210-6 into the hole of #207-6, and then put #210-6 into the notch of #223-6.
- [N] After cocking #209-6 in the set-position, cement #210-6 onto #207-6, #209-6 should have a slight play (0.1 - 0.2mm).
- [C] Make sure that #209-6 will be firmly locked in place.

Standard play at lever end :
vertically less than 0.2mm
horizontally 0.1 - 0.2mm

Spring #221-1, Spring pin #210A-5

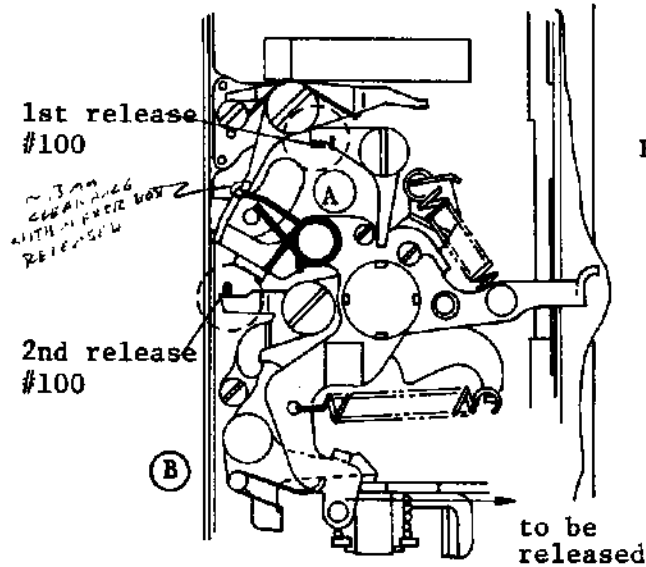


- [C] Check #211-6 for proper engagement and smooth movement.



to be screwed flush

Fig. 8-1 Spring #221-1 installation

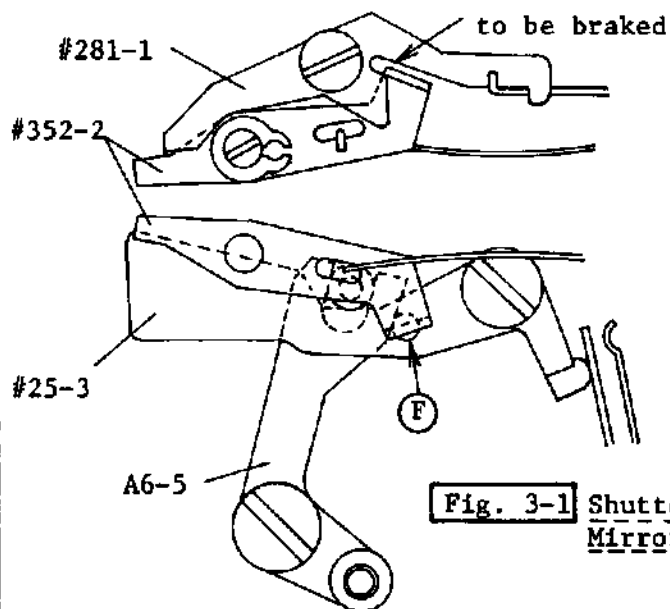
22-1 Mirror box installation**Fig. 1-1** Mirror box; side view Body (#1-5)

N The shutter is cocked, and the film-advance lever is stand-off position.

Front plate ⊕ #810 x 5 ⊕ #839A x 1

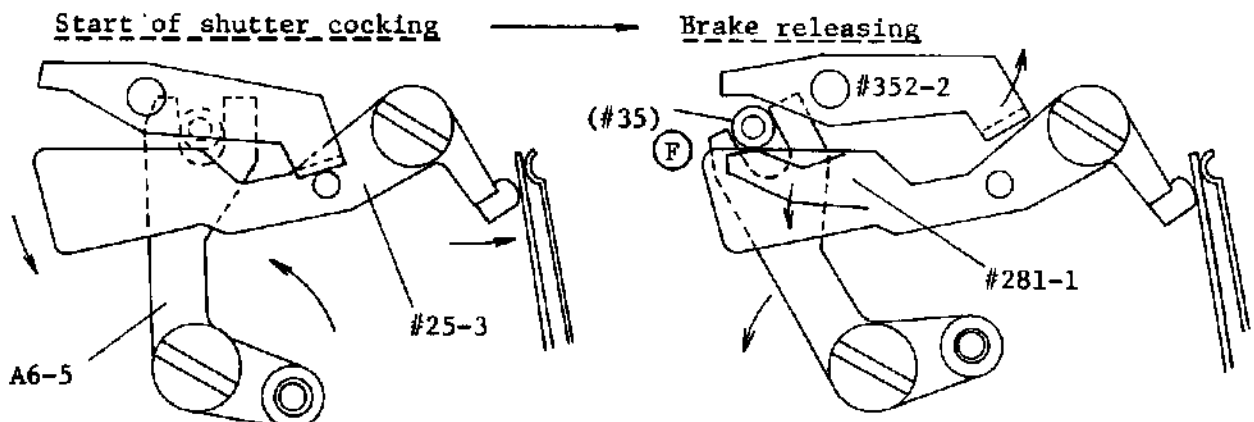
N Mirror-down lever B13-6 is released (See Fig. 1-1).
Shutter brake is released (See Fig. 3-1).

R Engagement position
A B C D are referred in Page 92.
E Brake release lever #281-1, Mirror charge pin collar #35.
F (Motor switch coupling lever #25-3 / MD take-up signal middle lever #352-2) is referred in Fig. 3-1 and 3-2.

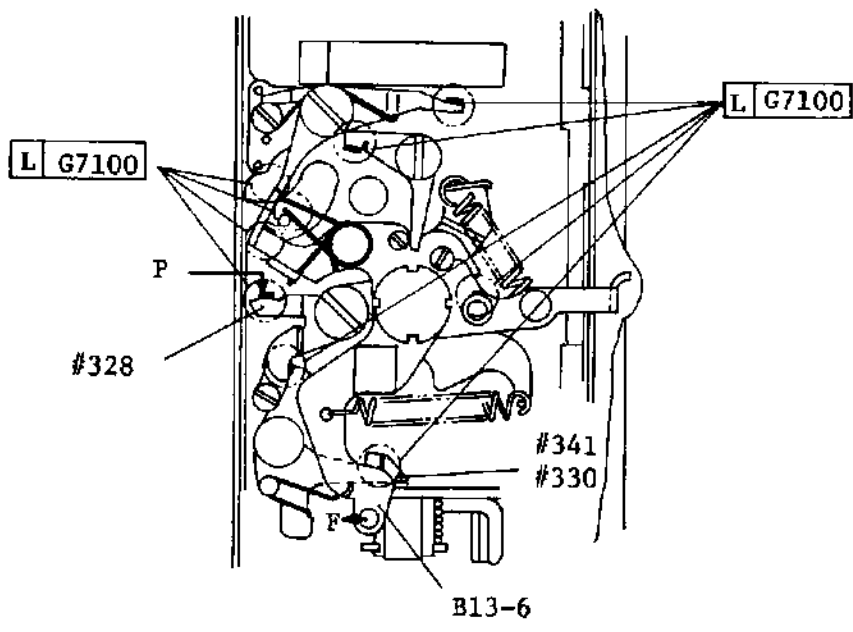


R Signal lever #328 should be placed downwards in the direction of arrow. Fig. 37-1.

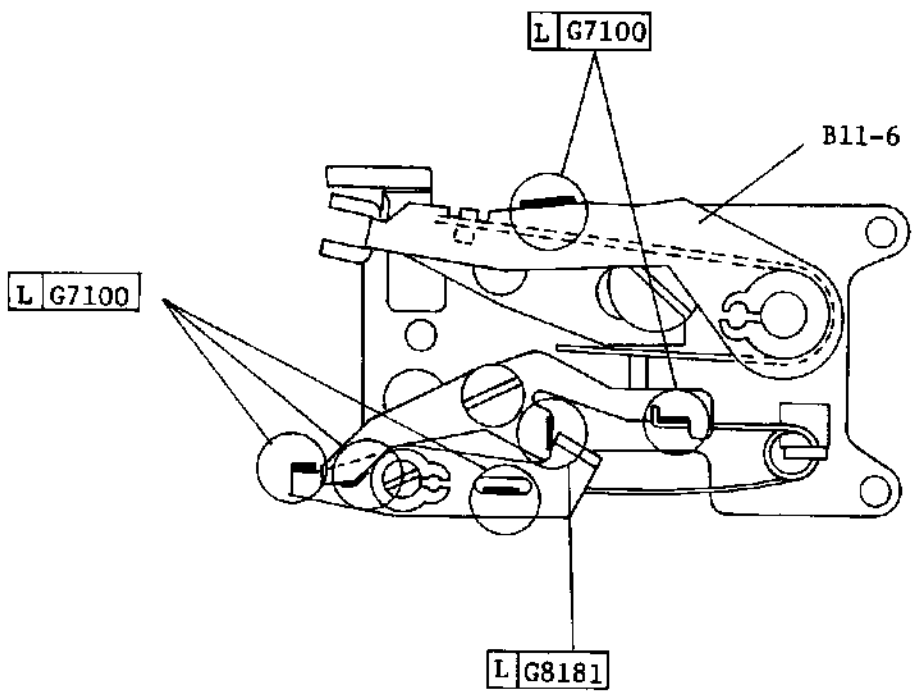
First put Front plate B-6 into the camera body, holding it upwards (there is a slight distance between the bottom of B-6 and the bottom plate of camera body), and then depress B-6 downwards in place, with the film-advance lever stroked.

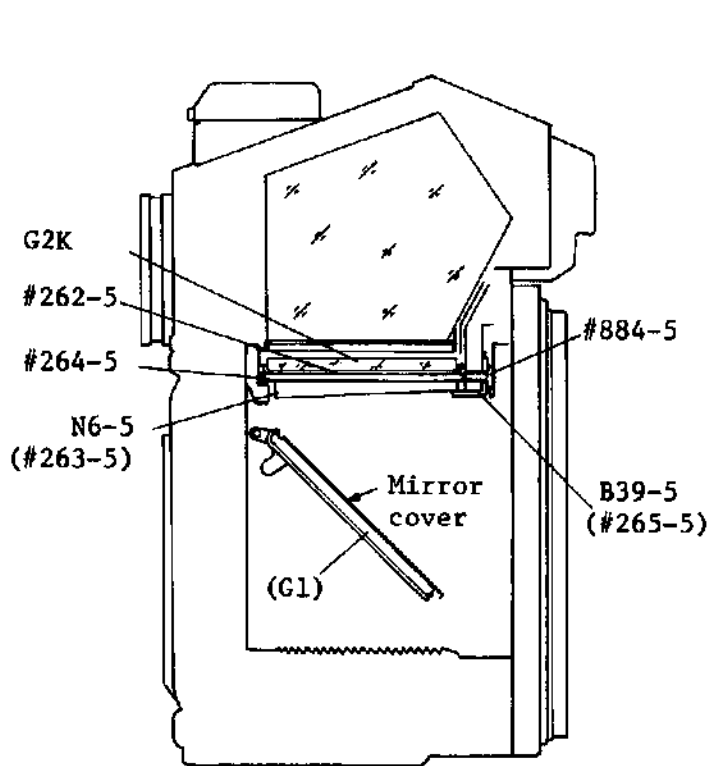
Fig. 3-1 Shutter is charged.
Mirror box is released.**Fig. 3-2**

22-2 Mirror box lubrication



Shutter brake lubrication



25-1 Focusing screen disassembly

⊕ #884-5
Focusing screen retainer B39-5
[N] Do not damage the mirror with a screw driver blade

Focusing screen frame holder N6-5
Focusing screen spring #264-5

[T] J15078
[R] Use J15078 to cover the focusing screen. when N6-5 and #264-5 are removed.

Focusing screen G2K, Focusing screen frame #262-5

[T] J15078
[R] Drop G2K onto J15078

Focusing screen assembly

Focusing screen G2K, Focusing screen frame #262-5

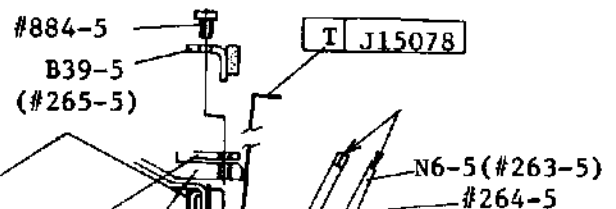
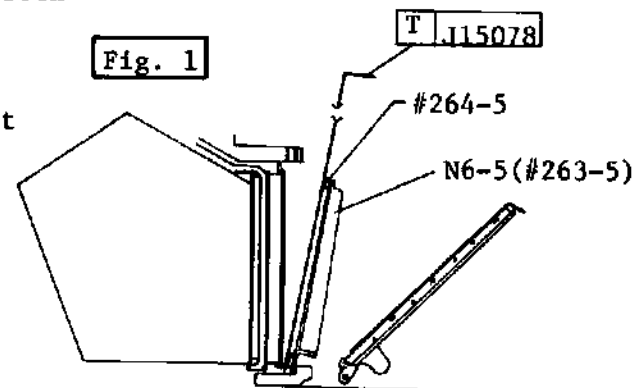
[T] J15078
[R] Hook J15078 to #6-6 and put G2-K onto it to be slid into place.

Focusing screen Frame holder N6-5
Focusing screen spring #264-5

[T] J15078
[R] Holding G2K with J15078, install #264-5, N6-5 in place

Focusing screen retainer B39-5
⊕ #884-5

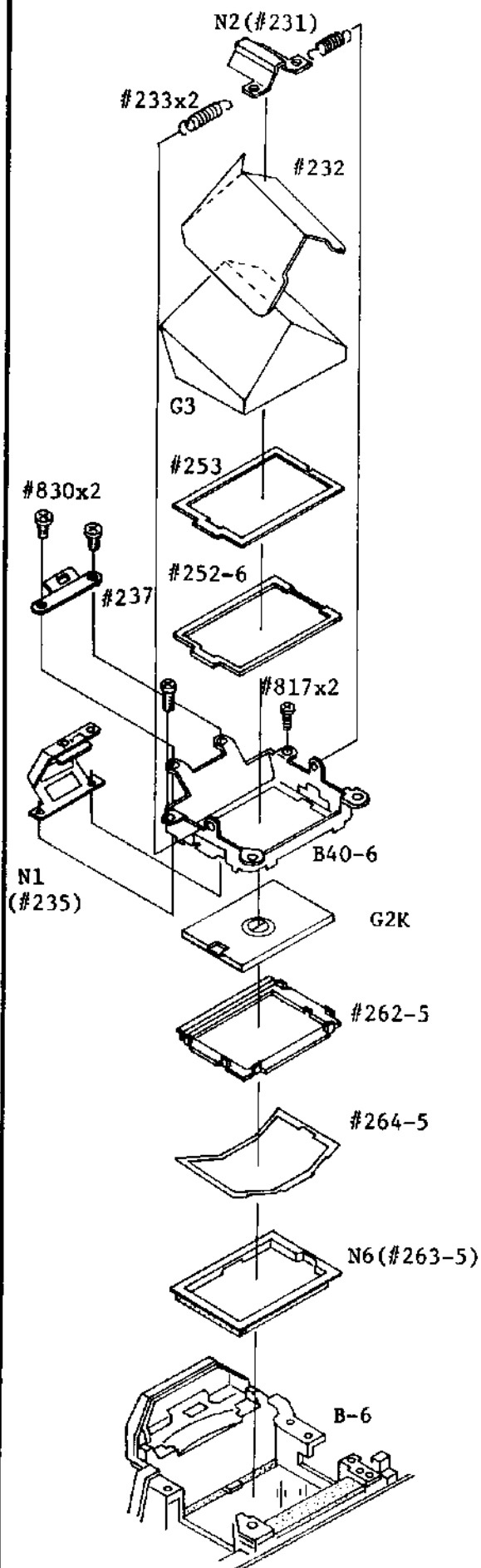
[R] After removing J15078, screw #884-5 to install B39-5



#201-6

(#6-6)

Fig. 2

25-2 Focusing screen / Penta-prism

Front plate #6-6

↓
Focusing screen frame N6-5

Focusing screen spring #264-5

Focusing screen G2K , Focusing screen frame #262-5

Ⓝ Watch out for the directions of parts installed.

Ⓜ The split-image of G2K faces the penta-prism.

↓
Prism box B40-6 ⊕ #817 x 2↓
F Mirror holder N1

F-mask plate #237 ⊕ #830 x 2

↓
Spacer #252-6

Prism mask #253

Penta-prism G3

Ⓝ Be careful-do not scratch G3.

↓
Prism retainer sheet #232

Penta prism retainer N2

Prism retaining spring #233 x 2

Ⓜ Hook one end of #233 to N2, and the other end to B40-6 from inside of the holes.

33A Aperture read out window positioning

- Use J18063 or J18065 to check aperture read out window position in the view field.

Standard : Right above 5mm-diameter circle of split-image range finder and microprism band

Height $b=0.3a - 1.5a$

Tilt : less than 2 degree from the edge line of viewfield (with visual estimation to the viewfield frame)

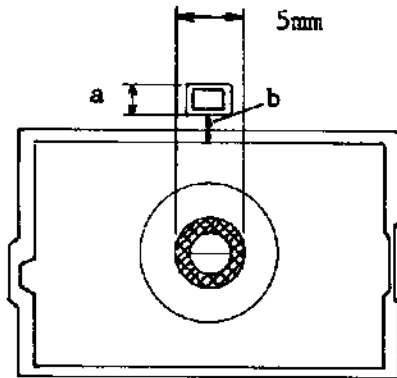


fig. 1

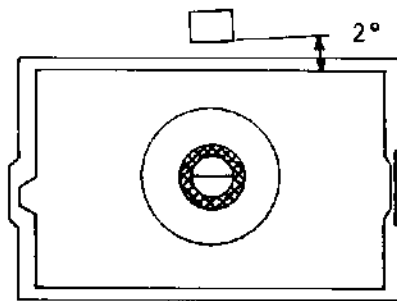


fig. 2

- Make sure that the window shows an aperture figure properly in the center, and that the next figure should not be insight. When use J18063, the guideline should be visible 0.3mm from the window edge line. (Fig. 3)

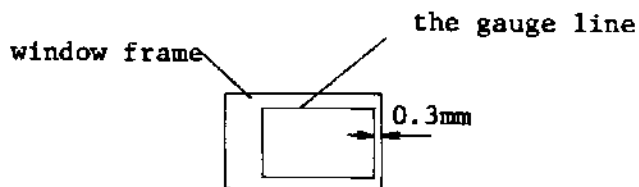


fig. 3

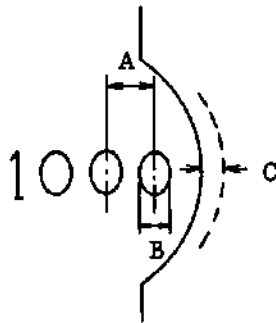
33B Shutter speed / exposure indicators positioningShutter speed indicator

fig. 1

- Check the shutter speed indicator at each shutter speed setting (B-1000), which should show the figures properly and give a photographer no unpleasant feeling.

- clearly visible...no dirt, no scratch, etc.
- inclination : $\pm 5^\circ$
- the viewfield edge line goes through Space A, Fig. 1.
- the rotational deflection : less than 0.3mm (B. C. are for guidance)

Exposure indicator

- Check the exposure indicators in the light, which should be positioned properly.

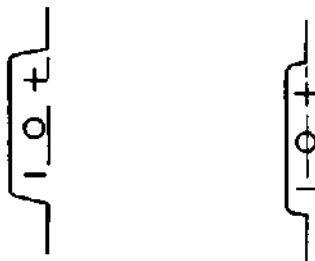


fig. 2

- clearly visible... no tilt, balanced between the edge line of view field, etc.
- the viewfield edge line goes through the center of indicator, Fig. 2.
- inclination : $\pm 2^\circ$

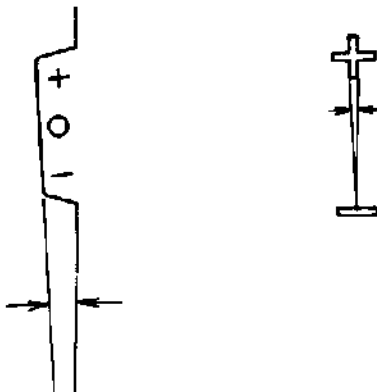
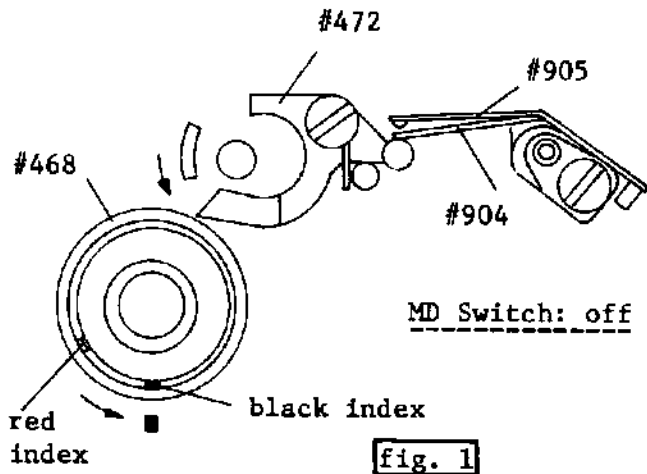
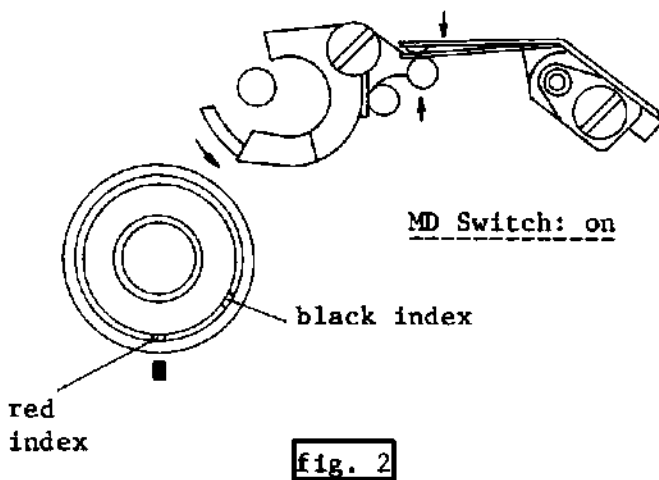


fig. 3

35A MD switch contact / Lever switch contact positioningMD switch contact positioning

- C Use J15138 to check the MD switch contact position, with MD-11 installed. Be careful—the film advance lever should return flush with the camera body.



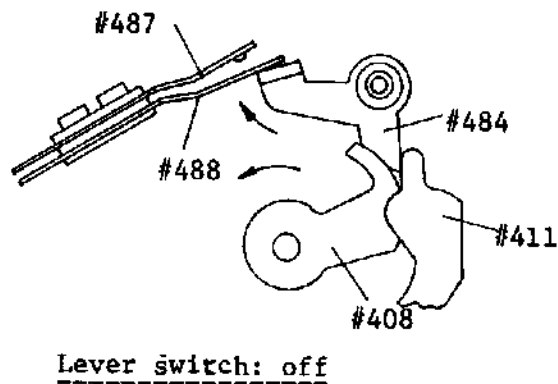
- C Turning the shutter operation mode selector to be aligned with the red line, see on-position when the motor drive starts working.

MD switch contacts #904/#905 should be closed just before the selector rotation reaches the line.

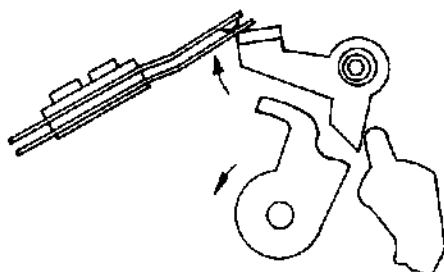
- A When necessary, adjust the clearance between #904 and #905.

Standard Switch off: about 1mm clearance between the switch contact

Switch on: about 50g contact pressure

Lever switch contact positioning

- C Use J15138 to check the lever switch operation. Details is to be refered on Page 104.



Lever switch: on

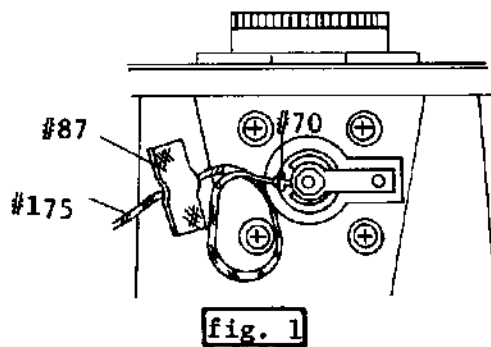
39 Top cover installation

fig. 1

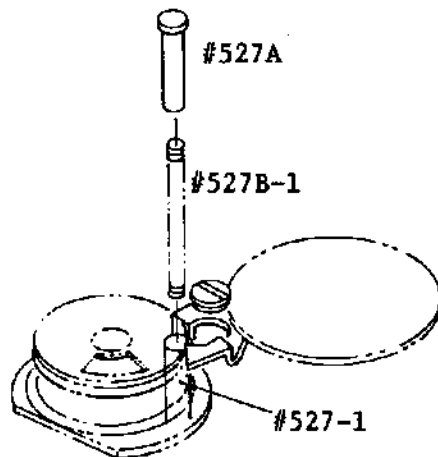


fig. 2

Lead wire, sync #175

- [R] Solder #175 to shoe switch contact, lower #70.
- [N] For preventing the wire cover from damage, loop the lead wire and apply Retaining tape #87 onto the loop.

Release middle shaft #527A, Spring #527B

Shoulder cover, right #39, Shoulder cover, left #40

Top cover C ⊕ #803 x 5

- [R] Before installation, set the shutter operation mode selector to the black line (off) and place the multi-exposure button toward the winding side.
- Replace Top cover C, being careful not to catch the lead wire between the cover and the camera body.

- [C] Check the followings after installation.

- 1) Proper engagement of the multi-exposure button with Multi-exposure arm A #490
- 2) Smooth operation of the shutter operation mode selector
- 3) Dirt / foreign matters in the view finder and in the frame counter window

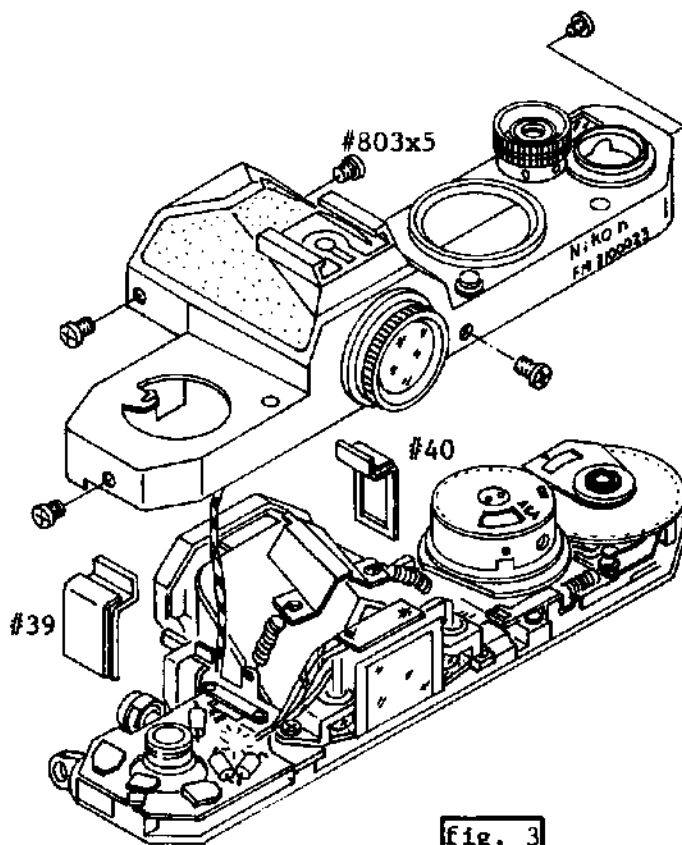
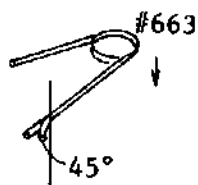
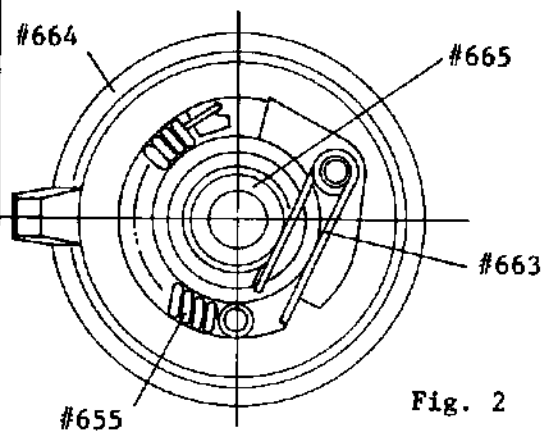
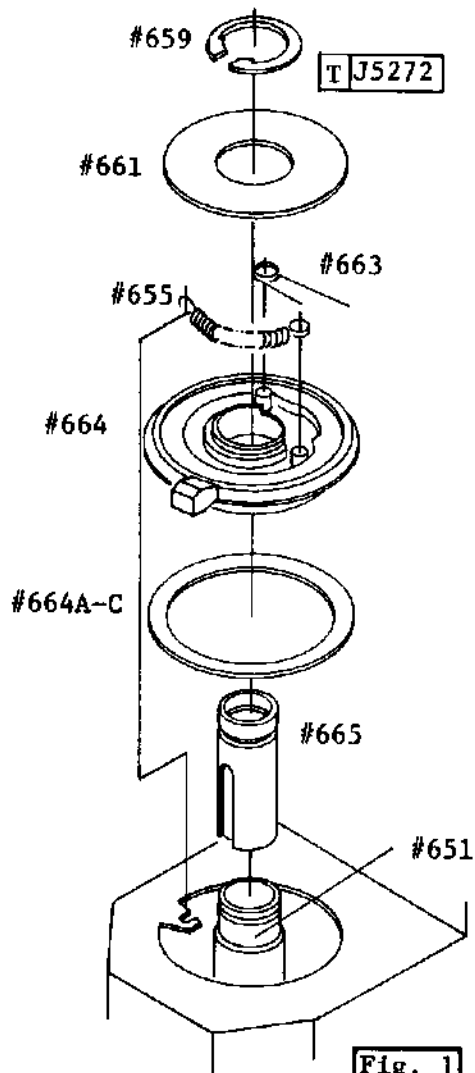


Fig. 3

40 Back cover lock knob installation

Body (#1-5)

↓ [R] Open the camera back.

↓ Rewind shaft guide #665

↓ [R] Align the slot of #665 with the stopper claw B.

↓ Back cover lock knob #664, Spacer #664A - C

↓ [A] Adding or removing #664A - C makes adjustments of clearance between #664 and the top cover.
(A=0.1t, B=0.2t, C=0.3t mm)

↓ Spring #655

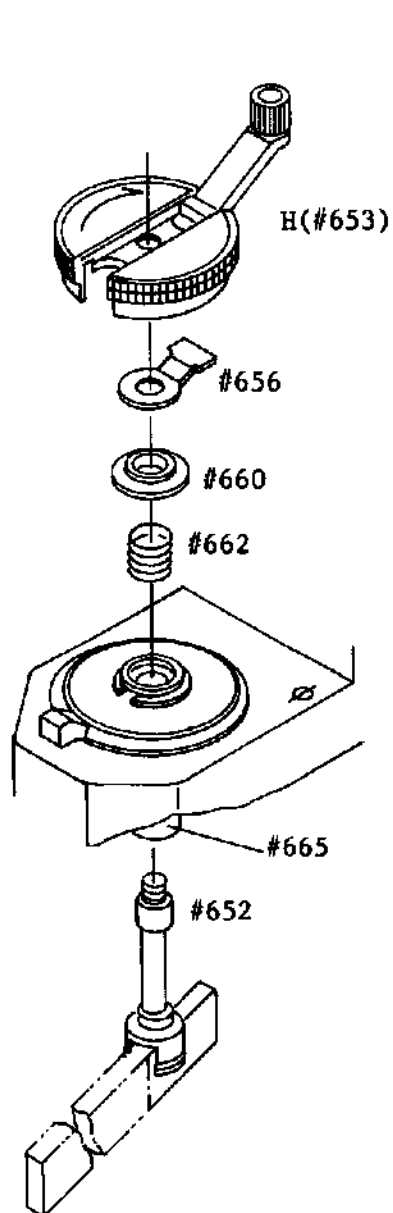
↓ [C] After hooking #655, check the smooth movement of #664.

↓ Spring #663

↓ [N] Watch out for the direction of #663 installed.
If a #663 has no bend at the end of longer arm, bend it by 45 degree for preventing dislocation.
See Fig. 2, & 3.

↓ Cover ring #661, Knob clip #659

[T] J5272

41 Rewind knob installation

Rewind knob shaft #652

↓
Friction spring #662, Washer #660,
Rewind lever spring #656

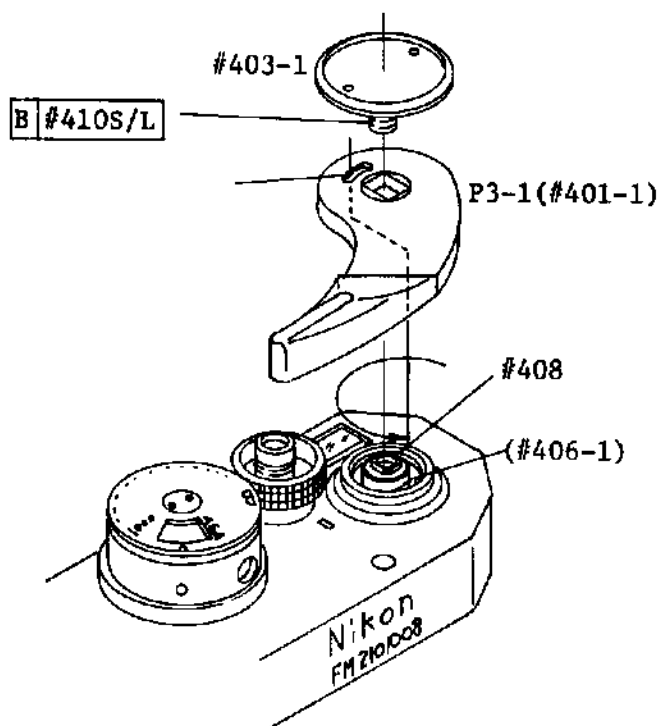
↓
Rewind lever H

- [R] Tighten H, after the rewind lever is aligned over #656
- [N] Do not deform the fork of #652 when tightening H.
- [C] Check the rewind knob for proper operation.

eccentricity: less than 0.2mm

42 Film-advance lever / Dial knob installation

Film-advance lever P3



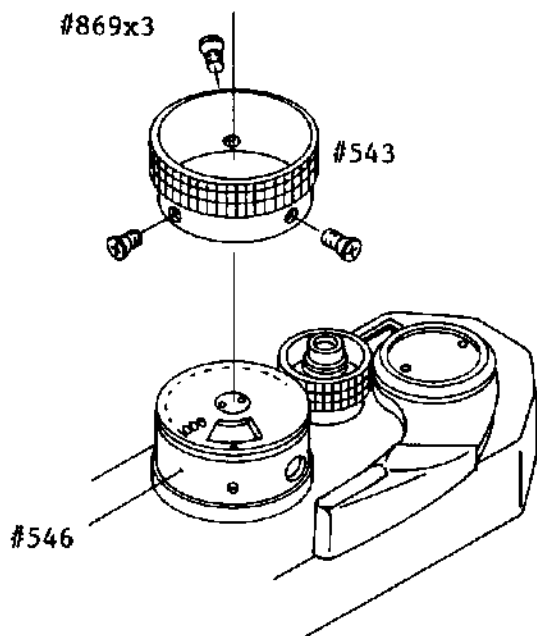
R First hook Spring #406-1 to the spring shoe, and turn P3 half turn counter-clockwise. Then fix it in place.

N Be careful not to dislocate #406-1 from Wind-up lever axle #408.

Cover screw #403-1

N With a locking agent #410 S/L applied, use J11126 to tighten #403-1 strongly.

C Check P3 for proper operation and switch contact. And P3 should have no play in a vertical direction (allowance at the lever end: less than 1.0mm)

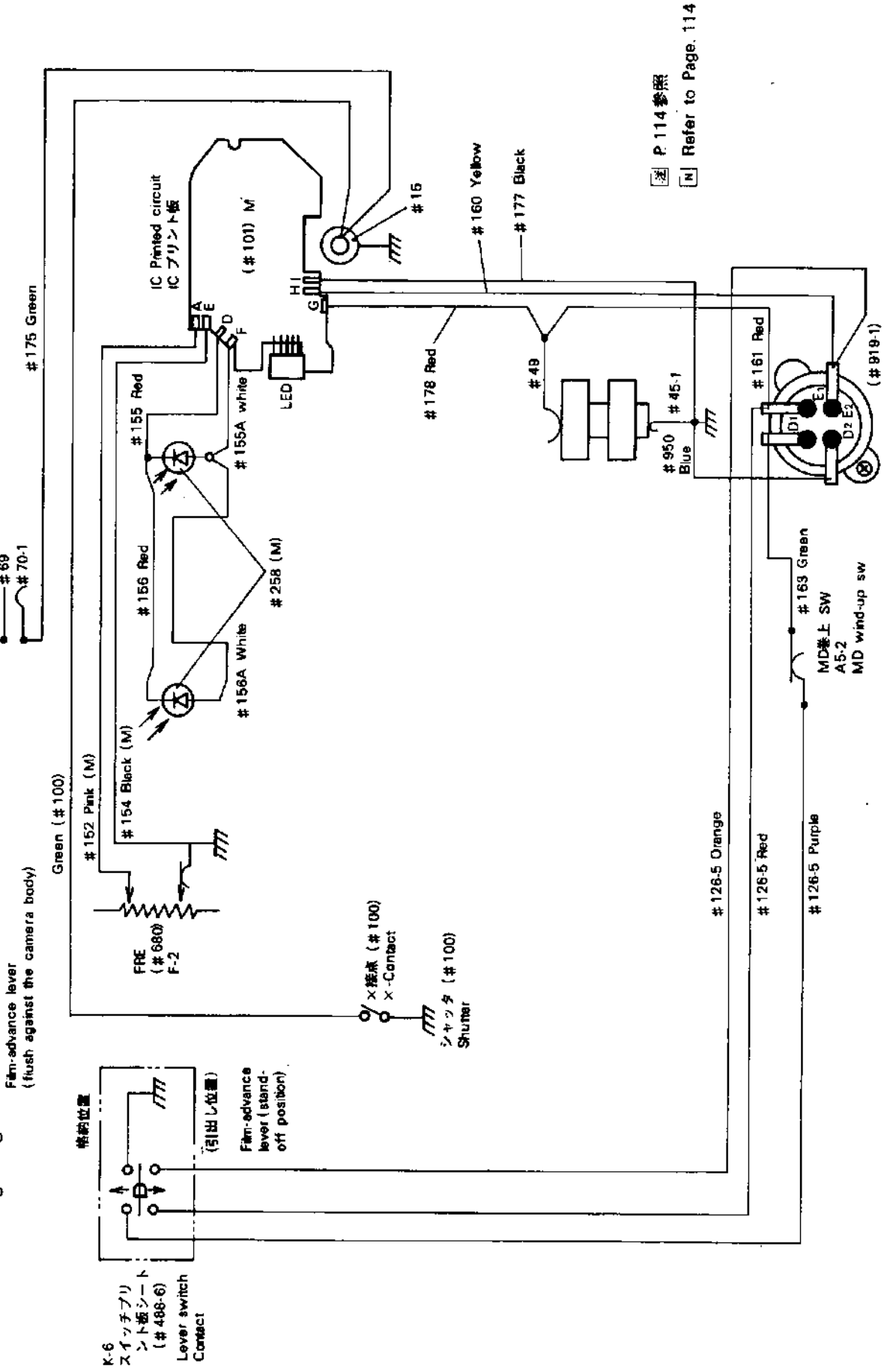


Dial knob #543 ⊕ #869 x 3

C Check the following after installation.

1. smooth setting of ASA
2. inclination: less than 0.3mm
3. The calibration plate should not protrude from #543.

総合配線図 Wiring Diagram



送 P.114 参照
N Refer to Page. 114

総合配線図
Wiring Diagram

Film-advance lever
(flush against the camera body)

Green (#100)

(#75) C1-1

#69

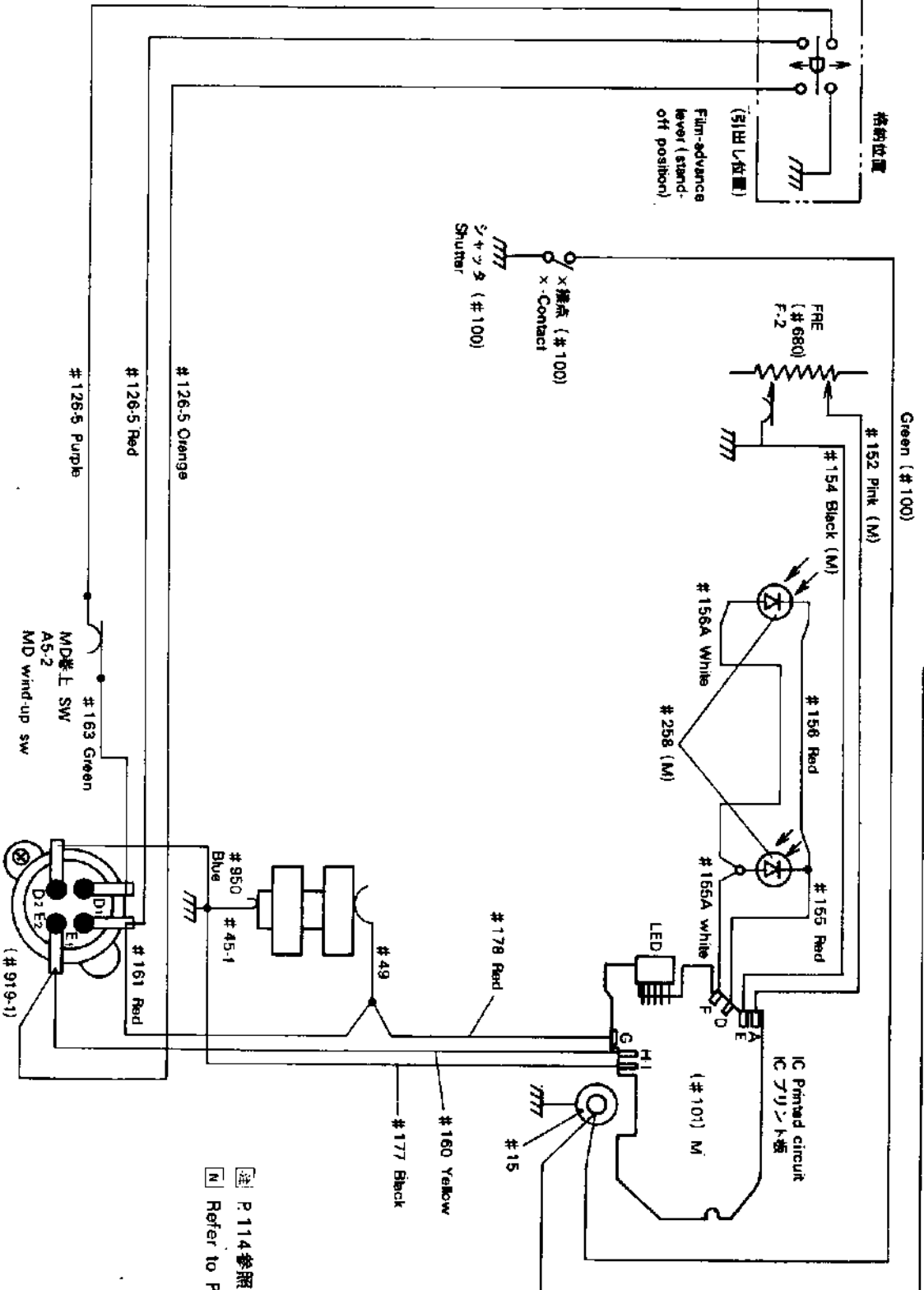
#70-1

#175 Green

K.6
スイッチ
レバーシート
(#488-6)
Layer switch
Contact

格納位置
(引出し位置)
Film-advance
lever (stand-
off position)

x 接点 (#100)
x-Contact
シャッター (#100)
Shutter



※ P.114参照
N Refer to Page. 114