

Minolta XD-11 Repair Guide

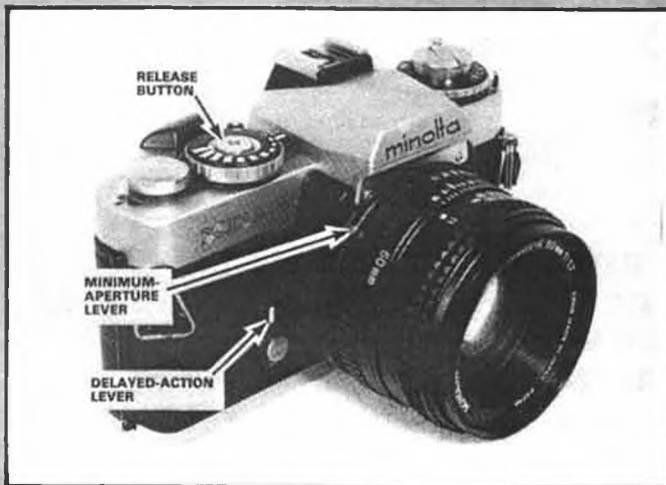

Figure 1B

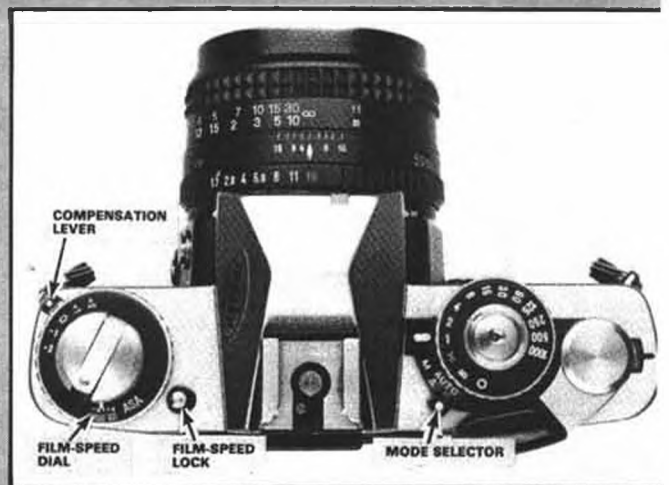

Figure 2

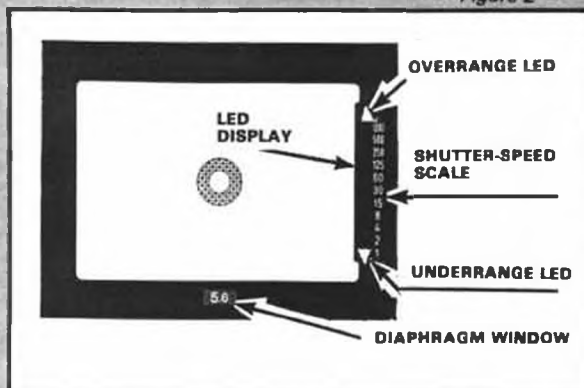

Figure 3

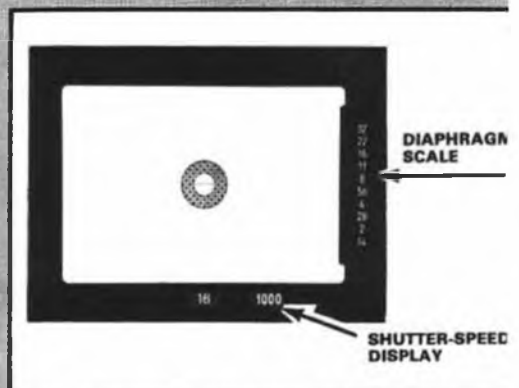

Figure 4



Figure 1A

CAMERA CAPSULE

Type: 35mm electronically controlled SLR with choice between aperture-preferred or shutter-speed preferred operation. Electromagnetic release. Full range of manually calibrated shutter speeds as well as automatic exposure control.

Meter: LED readout displays shutter speed or f/stop which the camera will automatically program. Silicon photodiode, full-aperture metering. Film-speed range — ASA 12 to ASA 3200.

Battery: Two 1.5V silver-oxide batteries S-76, G-13, MS-76, or RS-76. Negative ground. Battery compartment at bottom of camera. Behavior without batteries — shutter will not release except at mechanical speeds.

Shutter: Seiko MFC vertically traveling metal focal-plane shutter. Electronic shutter-speed control at auto and manual settings with two mechanically controlled settings — bulb and 1/100 second. Travel time — 6.0 to 6.9ms measured across a 20mm distance. Mechanical self-timer.

Lens: Accepts all Minolta MD lenses. Flange-focal distance 43.7mm (+0.02 — 0) measured from lens-mounting ring to pressure-plate rails.

Typical current draw with 3V supplied to battery compartment: Meter — 8.5ma, Shutter open — 17ma.

Circuit: Components are mounted on a flexible circuit board. You can replace individual components or the complete assembly. Three ICs. Memory switch is at

top of camera, metering switch and release switch are at back of front-plate assembly (controlled by release button), power switch is part of mirror-release combination magnet. Two combination magnets, one to release mirror and one to control diaphragm closure. Electromagnet for shutter-speed control, trigger switch, and X-sync contacts are shutter parts.

MINOLTA'S TRENDSETTER

The meteoric rise of the electronic, super-compact SLRs forced many camera manufacturers into a game of catch-up. But Minolta chose to set its own standards with the XD-11. Among other innovations, the XD-11 settled the debate over aperture-preferred vs. shutter-speed-preferred automation — it gives you a choice between either mode.

To program the camera for automatic shutter-speed control, set the mode selector to the "A" (aperture-preferred) position, Fig. 2. A mechanically controlled shutter-speed scale now moves into the finder, Fig. 3. When you push the release button part way, a row of LEDs indicates the shutter speed which the camera will automatically select. The appropriate LED lights alongside the shutter-speed calibration.

Triangle symbols in the LED display show the range limitations. If the combination of light level and diaphragm opening requires a shutter speed faster than 1/1000 second, the overrange LED turns on. The overrange LED indicates

that you're going to get an overexposure unless you select a smaller diaphragm opening. If the underrange LED at the bottom of the display turns on, you're going to get a shutter speed of 1 second or slower.

When you're using the "A" mode, you can leave the speed knob at any of the calibrated shutter speeds — 1 second through 1/1000 second. The automatic speed-control circuit disregards the speed-knob setting. As you select the f/stop, a tab on the diaphragm-setting ring rotates the camera's diaphragm-metering ring, Fig. 1. The diaphragm-metering ring moves a brush along a resistance band, thereby programming the f/stop information.

So far, the XD-11 sounds like most of the other electronic SLRs. But the XD-11 demonstrates its originality when you select automatic diaphragm control. Setting the mode selector to "S" (shutter-speed preferred) shifts the diaphragm scale into the finder, Fig. 4. Now the LED display indicates the diaphragm opening which the camera will automatically program. Also notice in Fig. 4 that the shutter-speed setting appears in the finder. At the "A" mode, Fig. 3, a mechanically controlled mask covers the shutter-speed display; the speed-knob setting has no meaning in the aperture-preferred mode.

For automatic diaphragm control, turn the diaphragm-setting ring to the smallest f/stop. A tab on the diaphragm-setting

ring then comes against the minimum-aperture lever, Fig. 1. As the tab pushes the minimum-aperture lever from left to right, it programs the metering system for the smallest f/stop of the particular lens.

Only the MD series of lenses has the minimum-aperture tab on the diaphragm-setting ring. Although the earlier MC lenses will couple to the diaphragm-metering ring, they don't have the tab which positions the minimum-aperture lever. So, if you install an MC lens on the XD-11, the LED display won't indicate an automatically programmed f/stop. You'll only be able to turn on one LED — the overrange LED.

You'll also get no diaphragm readout if you forget to set the smallest f/stop on the MD lens. The calibration for the smallest f/stop has a green color code. Since an optical system reflects the selected calibration into the finder, you can quickly set the diaphragm for the "S" mode. Simply rotate the diaphragm-setting ring until the green number appears in the finder, Fig. 4.

Now turn the speed knob to select the shutter speed you want. As long as the LED display indicates an f/stop in the usable diaphragm range, the camera delivers the shutter speed you've selected. It then limits how far the diaphragm can close according to your selected shutter speed and to the light conditions.

Since the XD-11 already has shutter-speed control circuitry, it can go an extra step to make sure you don't get an incorrect exposure. Perhaps the camera can't program the right f/stop for the particular combination of light level and shutter speed. A glance at the LED readout tells you to select a different shutter speed. But, if you fail to make the necessary correction, the camera's "computer" takes over — it automatically changes the shutter speed for you.

The camera lets you know when you're going to get a shutter speed that's different from the one you've selected — it turns on one of the range-limits LEDs as you start depressing the release button. If the overrange LED turns on, you'll get an exposure time that's faster than the speed-knob setting. If the underrange LED turns on, you'll get an exposure time that's slower than the speed-knob setting.

To program the diaphragm opening, the XD-11 controls the movement of the diaphragm-closing lever, Fig. 5. The diaphragm-closing lever moves from right to left before the mirror swings to the taking position. If the diaphragm-closing lever moves its full distance, it allows the diaphragm to stop down to the smallest f/stop. However, by limiting the movement of the diaphragm-closing lever, the XD-11 selects other aperture sizes.

A combination magnet (permanent magnet plus electromagnet) limits the movement of the diaphragm-closing lever. As the diaphragm-closing lever starts to move, the permanent magnet holds its armature. Then, when the diaphragm reaches the proper opening size, the circuit discharges a capacitor through the coil that's wound around the permanent-magnet core. The spurt of current momentarily disables the permanent magnet.

Now the armature of the combination magnet jumps away from the core. And the pawl-shaped end of the armature engages the ratchet teeth of a gear which rotates as the diaphragm-closing lever moves. Stopping the rotation of the gear also stops the movement of the diaphragm-closing lever.

In turn, the diaphragm-closing lever stops the spring-loaded diaphragm from closing any further. At the other settings of the mode selector, the capacitor never discharges through the coil of the combination magnet. As a result, the

diaphragm-closing lever always moves its full distance. And the diaphragm stops down to the f/stop you've selected on the diaphragm-setting ring.

The third setting of the mode selector — the "M" setting, Fig. 2 — provides manually calibrated shutter speeds. With the mode selector at "M," the shutter always delivers the selected shutter speed. The LED display now serves as a cross-coupled meter; it tells you what shutter speed will provide proper exposure according to the light conditions and to the diaphragm setting. Also, as you turn the mode selector from the "A" position to the "M" position, the viewfinder mask uncovers the shutter-speed calibration in the finder, Fig. 4.

Although the speeds are manually selected at the "M" mode, they're still electronically controlled. Consequently, all three functions depend on battery power. In fact, even the shutter release requires battery power. A second combination magnet in the XD-11 releases the mirror when you push the release button far enough to close the release switch.

The XD-11 uses two S-76 silver-oxide batteries housed at the bottom of the camera. What if the batteries die? You'll then find that the shutter won't release.

But the XD-11 does provide two mechanical settings — "B" and "O," Fig. 2. At the "B" setting, the shutter delivers a mechanically controlled bulb action. A mechanical system then releases the mirror. At the "O" setting, the shutter mechanically delivers the fastest full-aperture shutter speed — 1/100 second. So, if the batteries die, you can turn the speed knob to "O" and continue using the camera with electronic flash.

The electronically controlled "X" setting also provides the flash speed of 1/100 second. However, the "X" setting does depend on battery power — both for the electromagnetic release and for

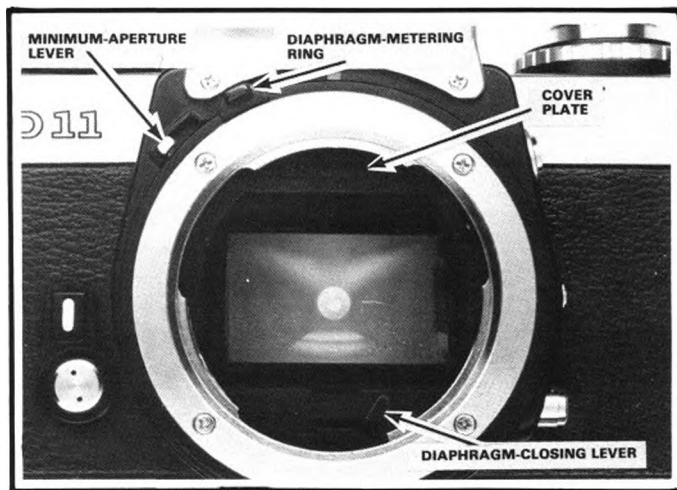

Figure 5

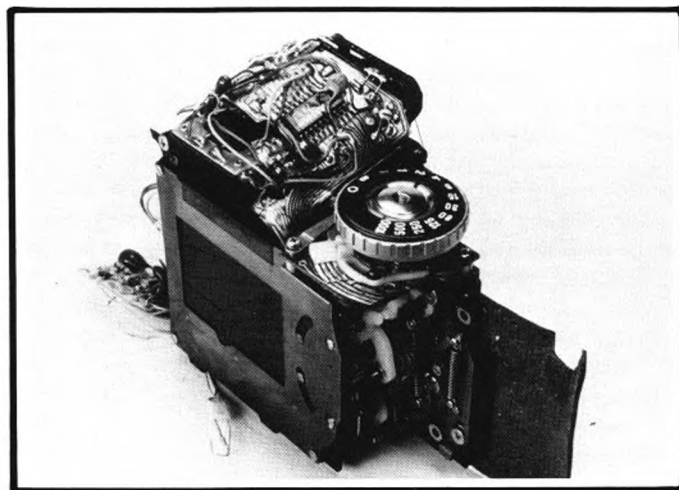

Figure 6 Front-plate/mirror-cage/shutter assembly

the electronically timed exposure. You can't use the "X" setting, the "B" setting, or the "O" setting for automatic exposure control. To help prevent a possible operator error, the LED display refuses to indicate a shutter-speed or diaphragm calibration at the "X," "B," or "O" settings. Rather, the overrange LED always turns on.

OTHER FEATURES OF THE XD-11

The XD-11 and its spinoff, the XD-5, both use the Seiko MFC modular focal-plane shutter. With a modular focal-plane shutter, you might expect the XD-11 to have a modular design. It does. But the XD-11 is even more modular than most cameras using similar shutters. You can remove the front plate, mirror cage, shutter, and flex circuit as one unit. Reaching the shutter takes a minimum amount of time.

Practically all of the electronic components mount to the flex circuit. In many cameras, the flex circuit causes repair problems; you must delicately lift aside portions of the flex circuit to disassemble the camera. However, the XD-11 eliminates such problems. Since the flex circuit comes off with the front assembly, Fig. 6, there's little chance of damage.

As is typical, the flex circuit covers the pentaprism. Fortunately, you don't have to lift aside the flex circuit to clean the focusing screen. For that matter, you don't even have to remove the top cover. To remove the focusing screen, take out the two screws that hold the plate at the top of the mirror cage, Fig. 5. Lift out the cover plate and the focusing-screen retainer. You can now drop out the focusing screen from inside the mirror cage, Fig. 7.

Most of the remaining features are pretty typical of modern SLRs. Notice that the film-speed dial allows you to set intentional overexposures or underexposures, Fig. 2. When you select the film speed, the film-speed dial rotates a brush

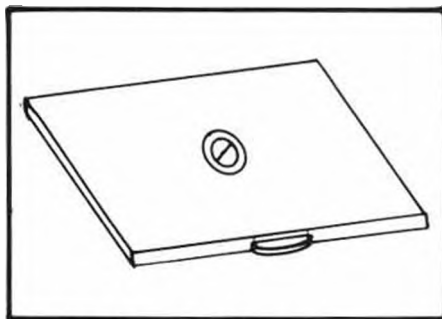

Figure 7 Focusing screen

along the film-speed resistor. Moving the compensation lever for intentional overexposures or underexposures rotates the entire film-speed resistor without moving the brush.

The XD-11 also accepts a power winder, the Auto Winder A, and the Minolta series of dedicated flash units. The 132X, 200X, and 320X dedicated flash units automatically program the camera for the flash speed of 1/100 second. When the flash unit charges, the overrange LED flashes on and off in the finder.

CIRCUIT AT THE BOTTOM OF THE XD-11

The battery-compartment cover screws into the bottom plate. So, once you remove the bottom plate, you can't power the camera with its own batteries. However, you can connect a 3V DC power supply to the battery compartment, Fig. 8. Connect the positive power-supply lead to the battery-compartment terminal and connect the negative power-supply lead to ground (any metal part on the camera). All the test voltages we'll be giving are positive with respect to ground.

As you cock and release the shutter, notice the actions of the two levers attached to the transport cam — the mirror-cocking lever and the shutter-cocking lever, Fig. 9. The clockwise rotation of the transport cam drives the mirror-

cocking lever left to right in Fig. 9. The end of the mirror-cocking lever then comes against the roller on the mirror-tensioning lever to charge the mirror. At the same time, the transport cam draws the shutter-cocking lever from left to right to charge the Seiko shutter.

The transport latch, Fig. 9, now drops into engagement with a notch in the transport cam. Consequently, you can't advance the wind lever a second time. After the exposure, the mirror-tensioning lever swings from right to left, Fig. 9, and strikes the transport-release lever. As the transport-release lever rotates in a clockwise direction, it disengages the transport latch from the transport cam.

A spring attached to the transport latch and the transport-release lever provides the switching contact for the power winder. With the shutter released, the power-winder switching contact moves into the power-winder locating bushing, Fig. 9. The locating bushing receives a pin on the power winder. So, with the power winder attached to the camera, the power-winder switching contact touches the pin.

The power-winder switching contact now connects the power-winder pin to ground. As a result, the power winder goes into action; it advances the film and cocks the shutter by rotating the power-winder coupler, Fig. 9. When the shutter reaches the cocked position, the transport latch drops into the notch in the transport cam. The transport latch now drives the power-winder switching contact away from the power-winder pin. Since the power-winder pin no longer connects to ground, the power winder stops running.

At the other end of the camera, you can see the circuit board which contains the mirror-release and diaphragm-control components, Fig. 8. Locate the two capacitors — C5 and C6. These are the capa-

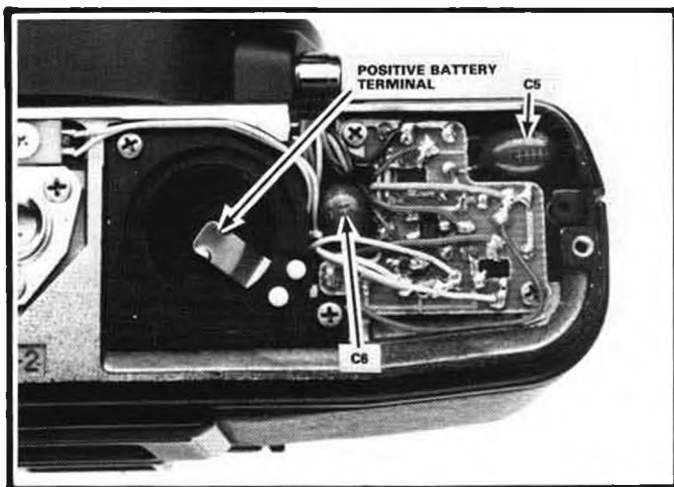

Figure 8

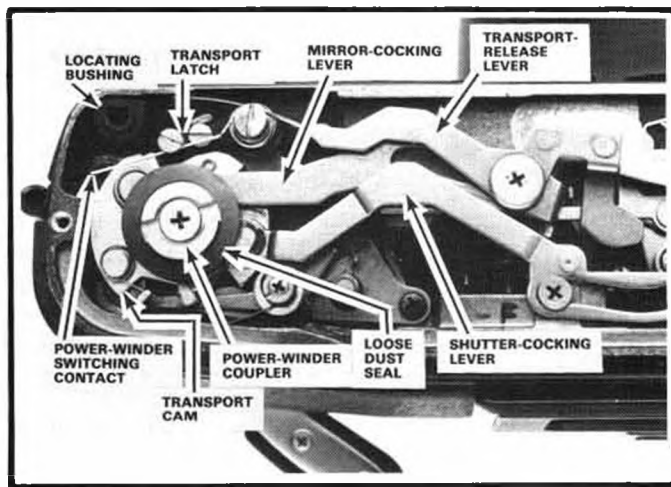

Figure 9 Shutter Cocked

citors that discharge through the coils of the combination magnets. C6 discharges through the coil of the mirror-release combination magnet M1; C5 discharges through the coil of the diaphragm-control combination magnet M2.

As yet, you can't reach the combination magnets. So, if there's a problem in either the mirror-release circuit or in the diaphragm-control circuit, you may have to remove the front-plate assembly. However, you can troubleshoot both circuits and pinpoint the malfunction without further disassembly. And, if you find that the problem is on the circuit board, Fig. 8, you can make the repair without disassembling the camera any further.

The two combination magnets have very similar circuits. Fig. 10 shows the circuit for the mirror-release magnet M1. Transistor T6 serves as a switch between

the mirror-release capacitor C6 and the coil of the mirror-release magnet M1. Turning on T6 allows the capacitor to discharge through the coil. The spurt of current causes the armature of M1 to jump away from the core and release the mirror.

You can see the M1 armature in Fig. 11. Also locate the mirror-release lever in the same illustration. When you push the release button, you should see the end of the M1 armature move toward the front of the camera and strike the mirror-release lever.

Transistor T6 gets the release signal from the comparator, Fig. 10. When the release switch closes, the control circuit sends a signal to the comparator. The comparator then switches from a high state to a low state. The low voltage applied to the base of T6 turns on the transistor. T6 now allows the capacitor to

discharge through the coil of M1.

But notice in Fig. 10 that switch S1 must be closed before the comparator output connects to the base of T6. S1 sits at the bottom of the camera, Fig. 11. When you cock the shutter, S1 closes to connect the comparator to T6. S1 opens after the exposure.

You can also see the part that actuates S1 in Fig. 11 — the nylon lug on the transport-release lever. As the transport-release lever swings in a clockwise direction, it allows S1 to close. Then, when the mirror-tensioning lever drives the transport-release lever in a counterclockwise direction, the nylon lug pushes the long blade of S1 away from the short blade.

S1 serves as a reset switch for the circuit. But, if S1 fails to close or makes poor electrical contact, you'll only note

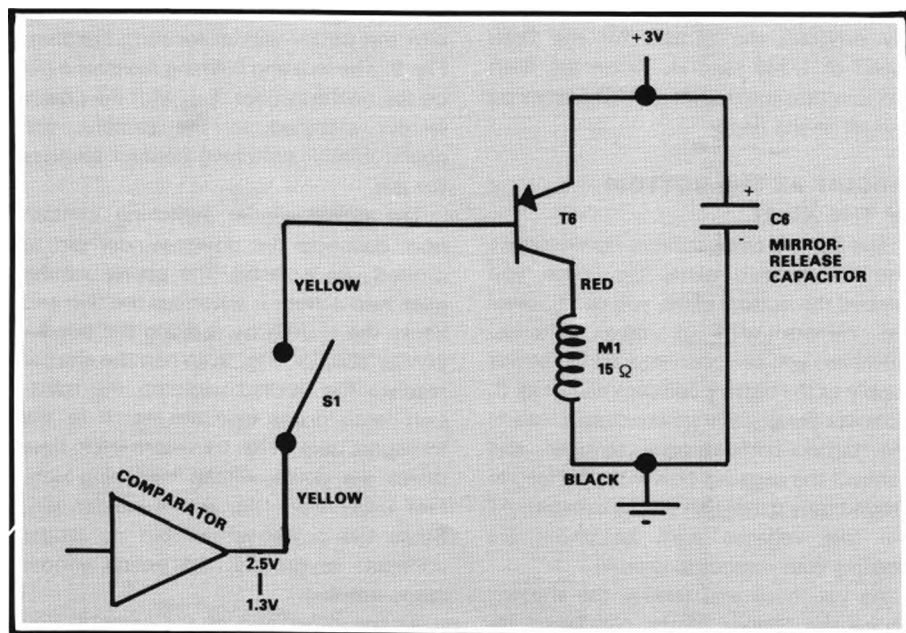

Figure 10

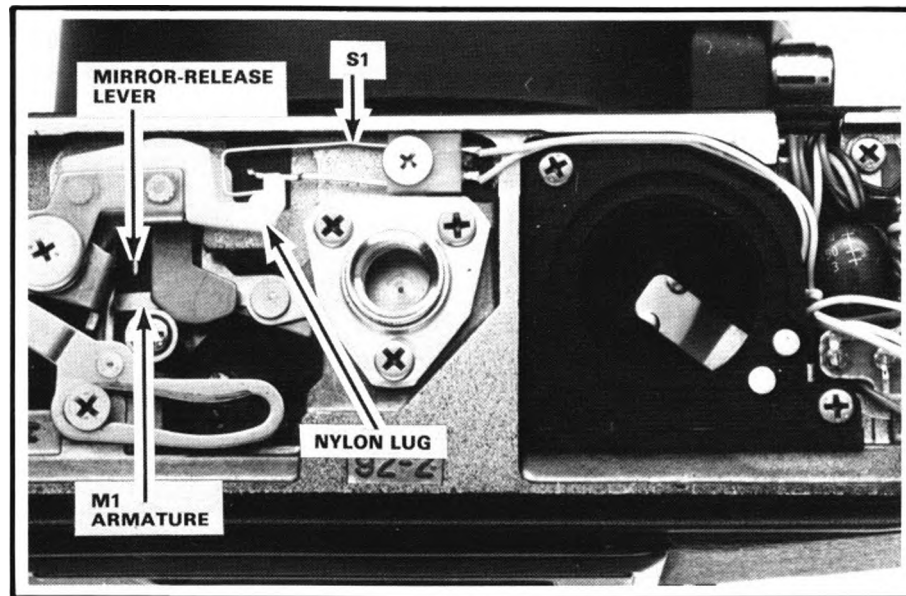

Figure 11

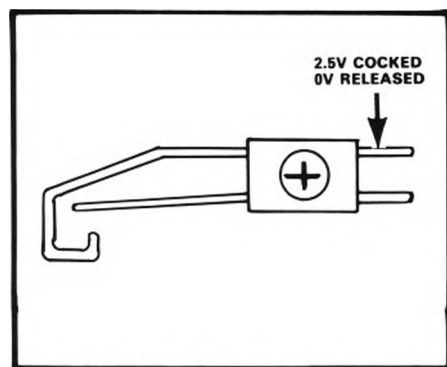

Figure 12 Reset Switch S1

one malfunction in the camera — the shutter won't release. With S1 open, transistor T6 never gets the low-voltage signal from the comparator.

You can check S1 with a voltmeter. At the long blade of S1, Fig. 12, you should measure 0V with the shutter in the released position. You should measure around 2.5V at the short blade, regardless of whether the shutter is cocked or released. Since S1 should close when you cock the shutter, you should also measure around 2.5V at the long blade. What if you measure 0V at the long blade with the shutter cocked? Apparently, S1 isn't closing.

If you have to reform the blades of S1, check the timing. Cock the shutter and hold the wind lever fully advanced. Then, while measuring the voltage at the long blade of S1, allow the wind lever to return slowly to its rest position. S1 should remain open as the transport latch drops into the first step in the transport cam, Fig. 9. But S1 should close when the transport latch drops into the second transport-cam notch. So, as soon as the transport latch drops into engagement with the second notch, you should measure around 2.5V at the long blade of S1. If the timing isn't correct, reform the S1 blades.

TROUBLESHOOTING THE ELECTROMAGNETIC RELEASE SYSTEM

If the shutter fails to release electromagnetically, you might first suspect switch S1. But you can also check the other possibilities after removing the bottom plate. The mirror-release magnet M1 may have an open coil, the mirror-release capacitor C6 may be open or shorted, transistor T6 may be open, or T6 may not be getting the release signal from the comparator.

It's also possible that the problem is mechanical rather than electronic. To check the mechanical release action, cock the shutter and push the M1 armature, Fig. 11, toward the front of the camera. The mirror should release. If it does, you know the mechanical release is working properly. And the problem must be with

the circuit.

Fig. 13 shows the approximate voltages you should measure across the M1 components. Notice that the mirror-release capacitor C6 charges to the full battery voltage. You should measure the +3V at the positive terminal of C6 regardless of whether the shutter is cocked or released.

However, before measuring voltages, you might try a quick shorting test to simultaneously check both capacitor C6 and the coil of magnet M1. Cock the shutter. Then bypass transistor T6 by shorting between its emitter and collector, Fig. 13. The mirror should release.

If your shorting test releases the mirror, you know that both the combination magnet M1 and the mirror-release capacitor C6 are good. You might next try checking for the release signal at the base of transistor T6, Fig. 13. Without de-

pressing the release button, you should measure around 2.5V — the output of the comparator in the "high" state. If you measure the full 3V signal, T6 apparently has a base-to-emitter short. Now depress the release button. The signal should drop to around 1.3V.

If the circuit fails to supply the release signal to the base of T6, you'll have to go further in the disassembly. There may be a problem with the release switch or with the release circuit. But if the transistor T6 is at fault, you won't have to go any further. You can make a final check on T6 by shorting between the base and the collector, Fig. 13. Your short connects the base to ground through the coil of M1. If the transistor is good, the mirror should release.

Replacing the transistor gives you a choice in repair procedure. Minolta does supply the individual components. But you may prefer to replace the complete circuit board (circuit base plate B).

Now let's say that the shutter doesn't release when you short between the emitter and collector of T6. Either the combination magnet M1 or capacitor C6 could be at fault. But you might first suspect the coil of M1. The red wire connected to the collector of T6 goes to one side of the coil; the other side of the coil connects to ground through a black wire, Fig. 13. To check the coil, measure the resistance between the red coil wire and ground. You should measure a very low resistance — around 15 ohms. If you measure no continuity, you know that the combination magnet M1 has an open coil. You'll then have to remove the front-plate assembly to replace the combination magnet.

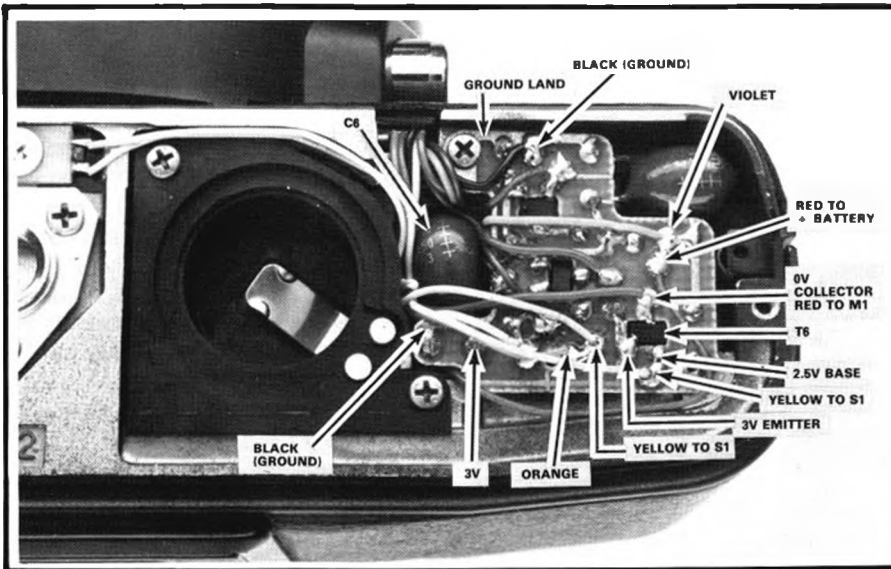

Figure 13

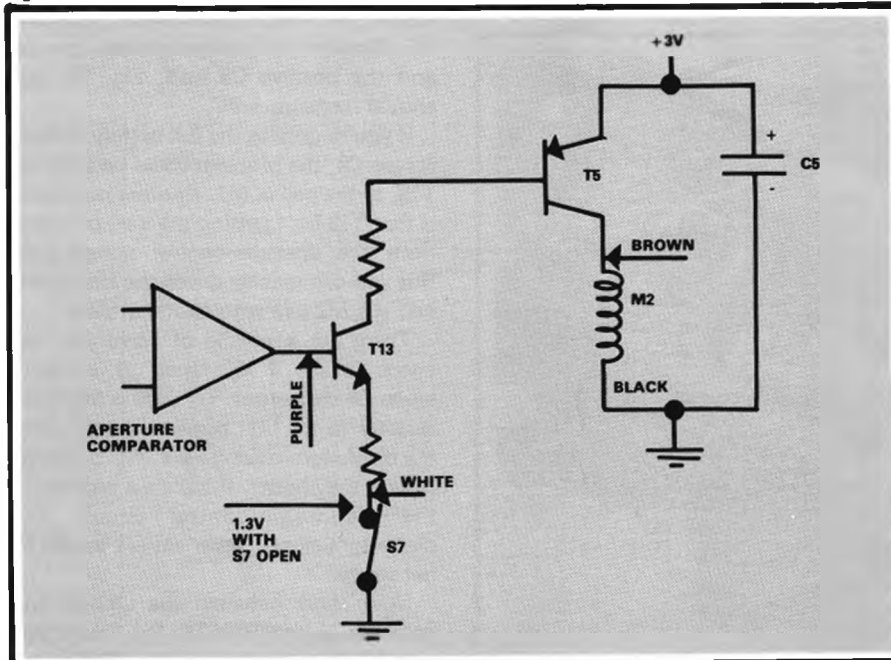

Figure 14

CHECKING THE DIAPHRAGM-CONTROL CIRCUIT

You can follow practically the same troubleshooting procedure to check the circuit for the second combination magnet — the diaphragm-control magnet M2. Remember, the diaphragm-control magnet arrests the diaphragm closure in the "S" mode. If there's a problem in the M2 control circuit, the diaphragm always stops down its full amount.

In Fig. 14, note the similarity between the diaphragm-control circuit and the mirror-release circuit. When the diaphragm reaches the proper f/stop, the aperture-control comparator switches on transistor T13. T13 then supplies the base current which turns on transistor T5. Turning on T5 allows the diaphragm-control capacitor C5 to discharge through the coil of the diaphragm-control magnet M2. M2 now repels its armature to arrest the diaphragm-closing lever.

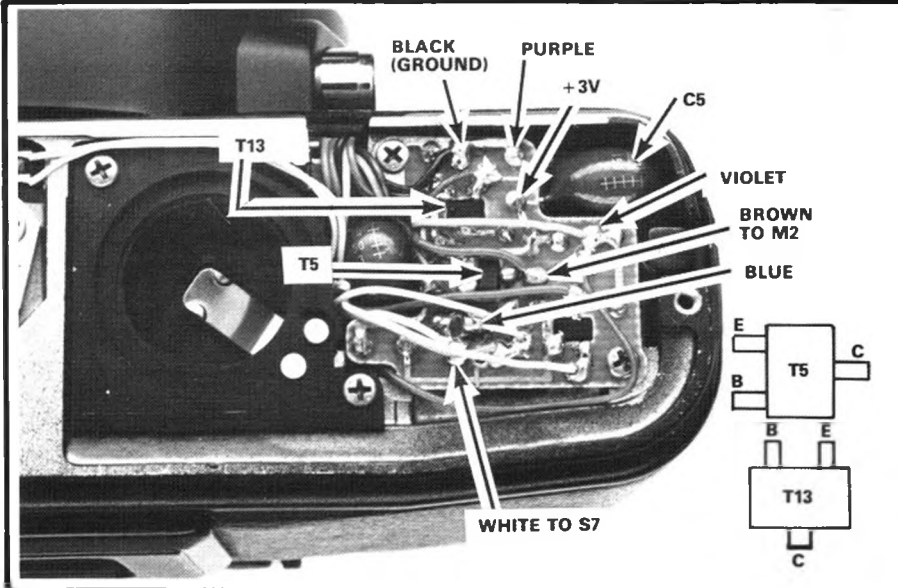

Figure 15

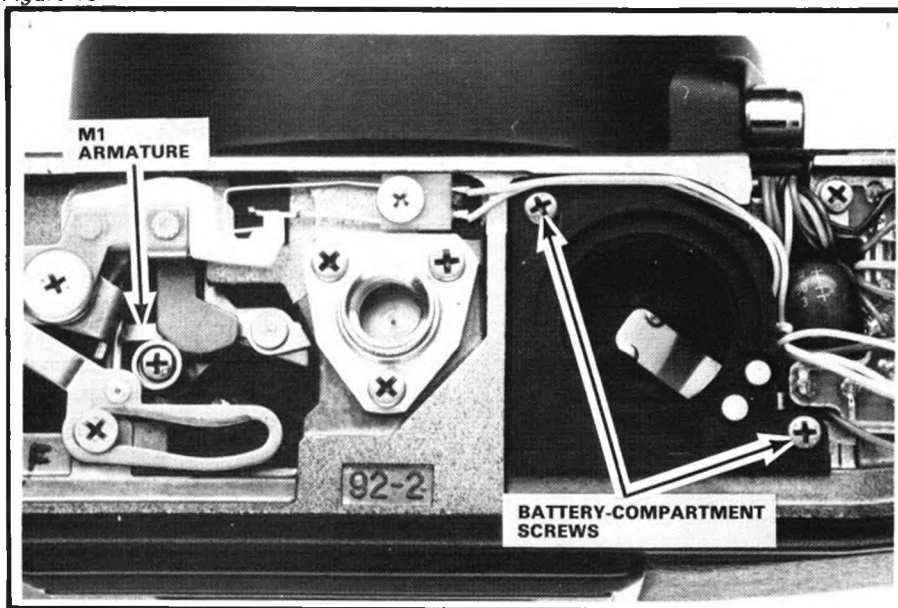

Figure 16

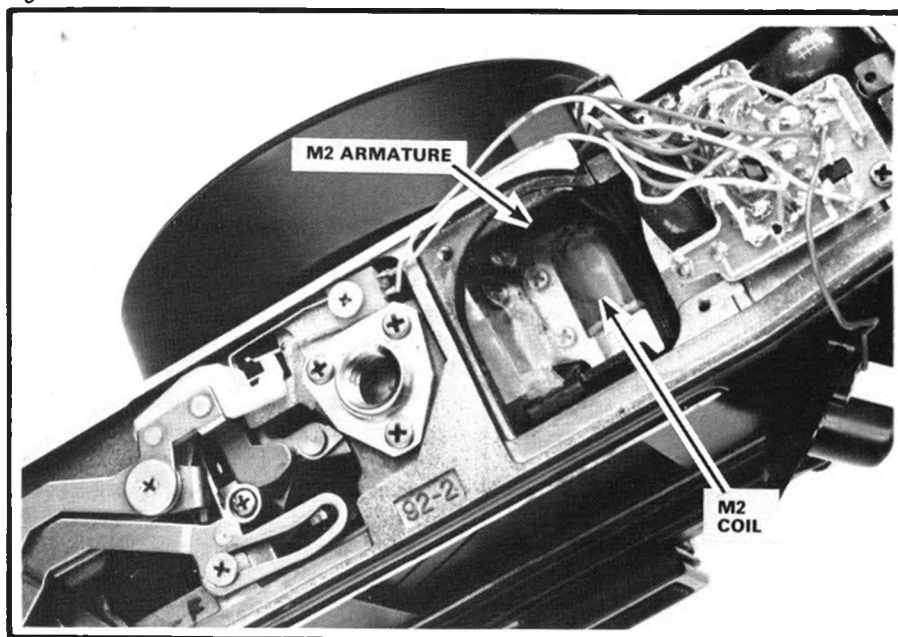

Figure 17

The components for the diaphragm-control circuit also mount to the camera board at the bottom of the camera, Fig. 15. But you can't as yet see switch S7. Switch S7 is part of the mirror-release-magnet assembly M1. As the armature of M1 jumps away from the core to release the mirror, it opens S7. Notice in Fig. 14 that S7 must be open in order for transistor T13 to conduct.

In effect, opening S7 turns on the diaphragm-control circuit. At the same time, S7 provides power for the shutter electromagnet (the electromagnet that holds open the closing blade for the length of the exposure). Opening S7 also switches off the LED display.

A problem with S7, then, could cause quite a few problems. Although you can't as yet reach S7, you can check its operation. Locate the white wire attached to the lower circuit board, Fig. 15. Measure the voltage between the white wire and ground; you should measure 0 volt, indicating that S7 is closed.

With S7 open, you should measure around 1.3V at the white wire. But how can you open S7 to measure the voltage? One way is to hold open the shutter at the bulb setting. Then push the M1 armature, Fig. 16, away from the M1 core (toward the front of the camera). The M1 armature now opens switch S7. Consequently, you should measure around 1.3V at the white-wire connection, Fig. 15.

The technique for holding open switch S7 also allows you to conveniently check the coil of M2 and capacitor C5, Fig. 14. Consider that the diaphragm-control circuit fails to latch the diaphragm-closing lever; the diaphragm-closing lever always moves its full distance in the "S" mode. You might first check for the charge across the diaphragm-control capacitor C5. Measure the voltage between ground and the positive C5 lead, Fig. 15; you should measure +3V.

If you're getting the full battery voltage across C5; the problem could be with T5, T13, or the coil of M2. Another possibility is that T13 isn't getting the turn-on signal from the aperture-control comparator. But you can quickly check the transistors and the M2 coil with shorting tests.

There are a couple of ways you can check to see if M2 repels its armature when C5 discharges. Try setting the mode selector to the "S" position. Then watch the diaphragm-closing lever, Fig. 5, as you release the shutter. If there's a problem in the diaphragm-control circuit, the diaphragm-closing lever always travels its full stroke.

Now short between the emitter and collector of transistor T5, Fig. 15, as you release the shutter. The diaphragm-closing lever should stop after traveling a

short distance. If it doesn't, you know that the diaphragm-control magnet M2 and the diaphragm-control capacitor C5 are both doing their jobs.

But you may find that it's easier to check the operation if you can actually see the armature of M2. Just pull aside the battery compartment by removing its two screws, Fig. 16. You can now see the M2 assembly through a clearance cutout in the bottom of the body casting, Fig. 17.

To check M2, hold open the shutter at the bulb setting and disengage the M1 armature as previously described. Remember, pushing the M1 armature away from its core opens switch S7. S7 must be open in order for transistor T13, Fig. 14, to turn on.

Now short between the collector and the emitter of T5, Fig. 15. You should see the armature jump toward the front of the camera. If the armature jumps away from the core, both M2 and C5 must be good.

You might then suspect transistors T5 and T13, Fig. 14. While still holding open the shutter on bulb with S7 open, try shorting between ground and the collector of T13, Fig. 15. Once again you should see the M2 armature jump away from its core. But, if the armature fails to move, transistor T5 must be defective.

If the armature does move, the problem may be with T13 or with the signal from the aperture-control comparator. You can make one more shorting test to check T13. Again hold open the shutter on bulb and open S7. Then short between the base of T13 and ground. If the armature jumps away from the core, there's no problem with T13. The problem must be in the aperture-control circuit. You'll have to remove the top cover to reach the IC that provides the turn-on signal.

Let's now consider the other possibility — the M2 armature does not release when you short across transistor T5. You might first suspect an open coil. To check the coil continuity, measure the resistance between the brown wire, Fig. 15, and ground. You should measure the resistance of the coil — around 15 ohms.

Also suspect the diaphragm-control magnet M2 if the diaphragm fails to stop down. Such a malfunction could indicate a problem either with the diaphragm-control magnet or with the circuit. But it's usually fairly easy to pinpoint the problem area — just check the operation at the different modes. If the diaphragm fails to stop down at all three modes — A, M, and S — suspect the diaphragm-control magnet M2. However, if the problem only occurs at the S mode, suspect the circuit.

When the diaphragm fails to stop down, the diaphragm-control magnet isn't holding its armature. The armature

then immediately arrests the the diaphragm-closing lever. If the problem occurs at all three modes, try cleaning the contact surfaces of the armature and of the permanent magnet, Fig. 17. Dirt can prevent the core from magnetically holding the armature.

If cleaning doesn't do the job, the permanent magnet may be defective. Try pushing the armature of M2 away from the core, Fig. 17; you should be able to feel the magnetic attraction. A defective permanent magnet requires that you replace M2, a job which means pulling the front-plate/mirror-cage assembly.

Now consider the other possibility — the problem only occurs at the S mode. The symptom indicates that the diaphragm-control circuit gets the release signal as soon as switch S7 opens. You can spot the problem by using the technique we described earlier at the bulb setting. Watch the armature of M2 as you push the M1 armature

toward the front of the camera, Fig. 16. If the M2 armature now jumps away from the core, the circuit is sending the release signal right away.

To verify the malfunction, you might try operating the camera at the S mode while you're shorting across the base and emitter of transistor T13, Fig. 15. Your short should keep transistor T13 shut off. And, as a result, the armature of M2 should remain against the core. If the armature still jumps away from its core, the problem is on the circuit board at the bottom of the camera — most likely, a shorted transistor. But if the armature remains against the core, the problem is in the circuit that sends the signal to T13. You must then remove the front-plate/mirror-cage assembly. The problem could be as simple as the violet wire's shorting to ground; or a switch or IC may be defective.

SUMMARY OF TROUBLESHOOTING AT BOTTOM OF CAMERA

As you can see, it's possible to check most of the electromagnetic diaphragm-closing and release systems from the bottom of the camera. What if the possibilities we've discussed don't get you to the problem? You'll then have to go further. For example, if the mirror won't release electromagnetically, the problem could be in the release switch. You can check the remaining switches just by removing the top cover. The following chart summarizes the troubleshooting covered so far.

SYMPTOM

Shutter won't release, LEDs do not operate

Shutter won't release, LEDs operate

Diaphragm fails to stop down, LEDs operate

All modes

S mode only

Diaphragm always stops down fully, "over" LED remains on

POSSIBLE CAUSE

No battery power to lower circuit board — check for 3V at red wire, Fig. 13. No voltage — check battery compart.

Release switch (remove top cover to check)

Coil M1 open

Capacitor C6

Transistor T6

Switch S1, poor contact

Solder connections to lower circuit board (red, black, yellow)

No release signal from comparator

Combination magnet M2, armature dirty or permanent magnet defective

Violet wire shorted to ground

Transistor T13

Comparator always presents release signal to T13

Solder connections to lower circuit board (purple, white brown, black)

Film-speed resistor open (remove top cover to check)

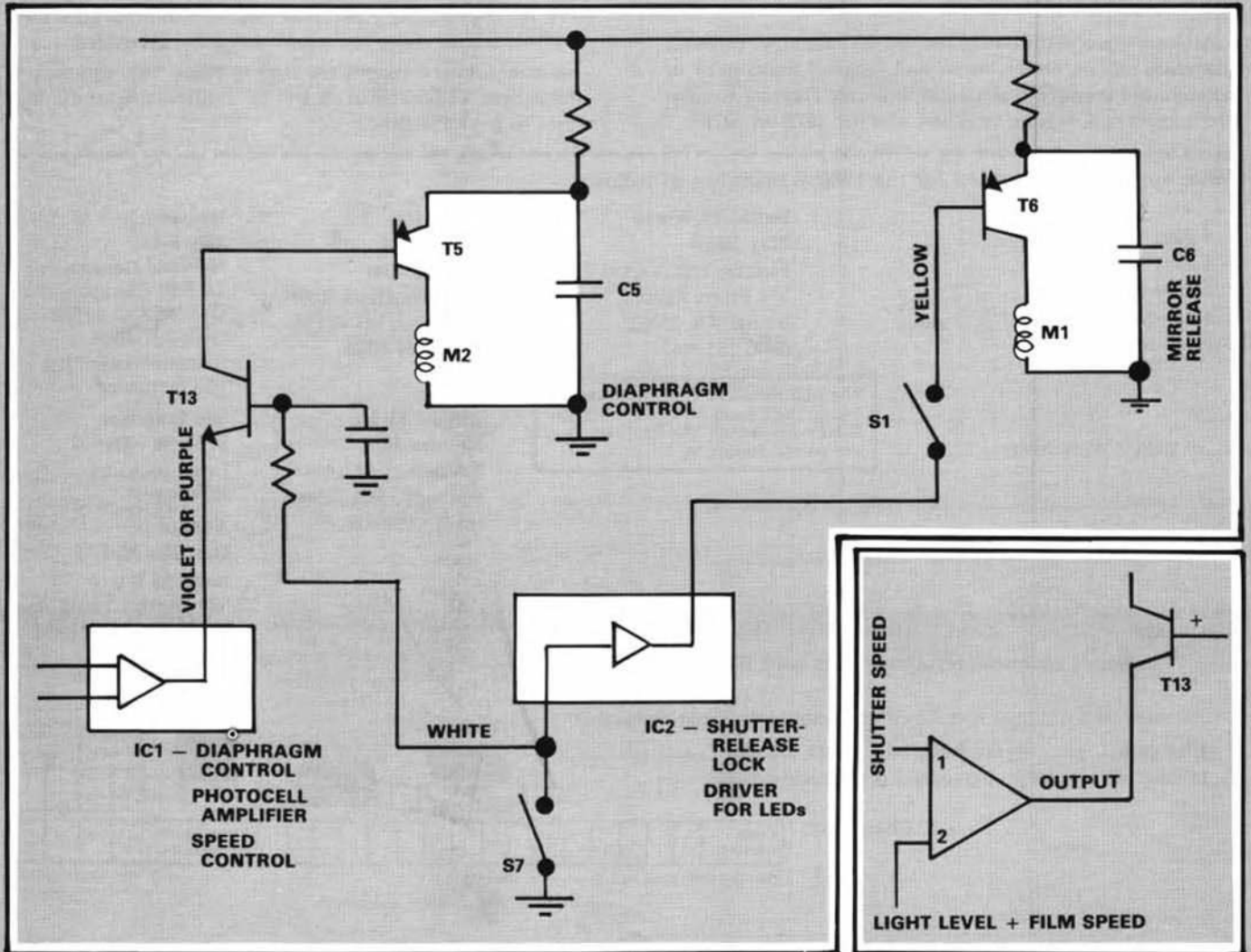

Figure 18 Actual schematic

Figure 19

ACTUAL CIRCUIT FOR THE COMBINATION MAGNETS

Fig. 18 shows the actual circuit for the combination magnets M1 and M2. The two IC's which drive the switching transistors mount to the flex circuit inside the camera. Notice in Fig. 18 that a comparator output of IC1 controls the potential on the emitter of T13; switch S7 connects to the T13 base (in the partial schematics used earlier for explanation, we showed the comparator controlling the base of T13).

With S7 closed, the base of T13 connects to ground. Opening S7 then connects the base of T13 to a positive voltage — around 1.3V, measured at the white wire, Fig. 18. T13 now has the voltage it needs at the base. However, the transistor can't turn on until the emitter voltage goes less positive than the base voltage.

The comparator inside IC1, Fig. 18, decides when it's time to turn on T13. IC1 actually makes its exposure calculation as the diaphragm stops down. At the "S" mode, IC1 compares the selected shutter-speed setting at one input with the light level and the film-speed setting at the other input. To stop the diaphragm at the proper f/stop, the comparator inside IC1 switches low. The emitter of T13 now goes less positive than the base. As a result, T13 turns on and allows C5 to discharge through the coil of M2.

You can see how the comparator makes its f/stop calculation in Fig. 19. The shutter-speed setting provides the input voltage to one input of the comparator; the combination of the film-

speed setting and the photocell output provides the voltage at the other input. If input #1 in Fig. 19 is less positive than input #2, the comparator output remains high to keep T13 turned off.

However, as the diaphragm stops down, the output of the photocell decreases. The voltage at input #2 then goes less positive. When the two inputs see the same voltage, the comparator knows that the diaphragm has reached the proper f/stop. Now the comparator switches states — its output switches low and turns on T13.

Earlier, we mentioned that S7 must open before T13 can conduct. If S7 remains closed, the base of T13 stays at ground potential. Remember, S7 opens when the mirror-release combination magnet M1 repels its armature. Opening S7 both applies the base bias to T13 and

disconnects IC2 from ground.

IC2 serves as the driver for the LEDs. So, when S7 breaks the IC2 ground connection, the viewfinder LEDs turn off. Also, IC2 provides the shutter-release lock for the mirror-release combination magnet M1, Fig. 18. If the battery voltage drops too low, the comparator inside IC2 won't switch on transistor T6. As a result, the mirror-release combination magnet can't release the mirror.

VARIATIONS IN THE LOWER CIRCUIT BOARD

As mentioned previously, the lower circuit board, Fig. 20, comes as a complete unit. Although we described techniques for checking the individual components, you can test the complete circuits with one shot — just short the bases of the control transistors to ground.

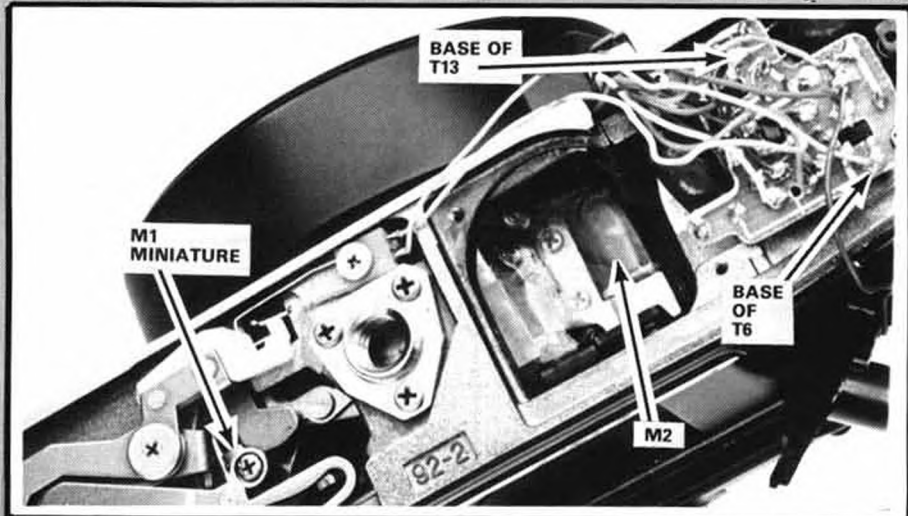

Figure 20

Check the diaphragm-control circuit by holding open the shutter on bulb. Then push the armature away from the core of M1, Fig. 20, to open S7. Now short the base of T13 (the violet or purple wire, Fig. 20) to the camera body. You should see the armature of M2 jump away from the core.

If shorting the violet wire to ground causes M2 to repel its armature, all of the diaphragm-control circuit on the bottom of the camera must be working. What if M2 doesn't repel its armature in normal operation? Apparently the comparator inside IC1 isn't switching low to provide the emitter bias for T13.

Similarly, you should be able to make the mirror-release magnet M1 repel its armature by shorting the yellow wire to ground (the yellow wire that connects to the base of T6, Fig. 20). Shorting the yellow wire to ground should turn on T6. If M1 repels its armature and releases the

mirror, the mirror-release components must be good.

If you find that there's a problem on the lower circuit board, however, you may run into a parts snag — there are two different versions of the board, and the two types won't always interchange. Fig. 21 shows the early version of the board; Fig. 22 shows the modified version.

Whether or not you can install the later version in an earlier camera depends on the flex circuit. You must then identify the flex circuit. Alternately, you may have to replace the complete flex circuit and the lower circuit board as a unit. You'll be able to identify the flex circuit after you remove the top cover.

REMOVING THE TOP COVER

Unscrew the wind-lever retaining screw. Then disconnect the end of the wind-lever return spring, Fig. 23, as you

lift off the wind lever. Also unscrew the top-cover retaining ring around the wind shaft, Fig. 24.

Next unscrew the retaining ring that holds the speed knob, Fig. 24. Although we used the bulb setting as a reference in Fig. 24, the actual shutter-speed and film-speed settings aren't important for disassembly. Remove the speed knob and note the loose release pin. The release pin closes the switches for the metering and release functions.

You can completely remove the camera back by depressing the hinge pin. Then unscrew the rewind knob. Remove the film-speed dial by unscrewing its retaining ring and take out the parts indicated in Fig. 25 — the detent plate, the black plastic decorator ring, the brass bushing, and the exposure-compensation lever.

Finally, remove the top-cover screws. Two of the top-cover screws also hold the diaphragm-window plate, Fig. 26. If you wish, you can remove the front decorator plate, Fig. 26, after you take off the diaphragm-window plate. However, unless you know you're going to remove the front-plate/mirror-cage assembly, you can leave the front decorator plate installed.

Before lifting off the top cover, push down the eyepiece-blind lever, Fig. 27. The eyepiece blind then covers the eyelens. This precaution prevents the other end of the eyepiece-blind lever from catching the flex circuit as you lift off the top cover.

REPLACING THE TOP COVER

When you replace the top cover, the mode selector, Fig. 24, must key to the mode switch, Fig. 28. Fig. 28 shows the mode switch set for manual shutter speeds — the "M" position. To set automatic shutter speeds, move the mode switch to the center position; move the mode switch all the way in a counterclockwise direction to set automatic diaphragm openings.

Normally, you'll find that the mode selector keys most easily at the "S" setting. Set the mode selector in the top cover to "S." Then turn the mode switch, Fig. 28, all the way in a counterclockwise direction. After seating the top cover, check to see that the viewfinder scale switches from the diaphragm calibrations to the shutter-speed calibrations when you move the mode selector to "A."

Also, with the top cover removed, the film-advance indicator, Fig. 28, tends to sneak under the counter dial. Tightening the retaining ring around the wind shaft, Fig. 24, then binds both the counter dial and the film-advance indicator.

The film-advance indicator only moves when there's film in the camera. As the

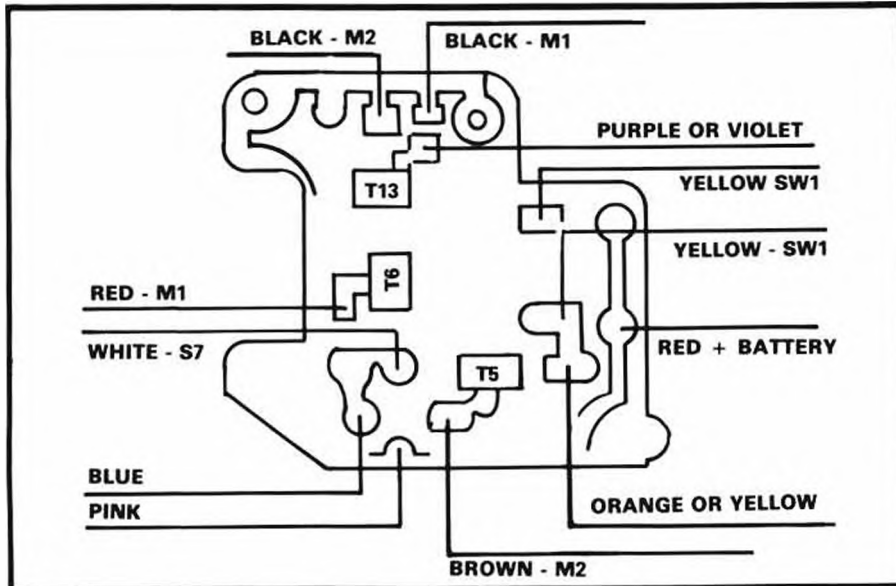

Figure 21 Early style board

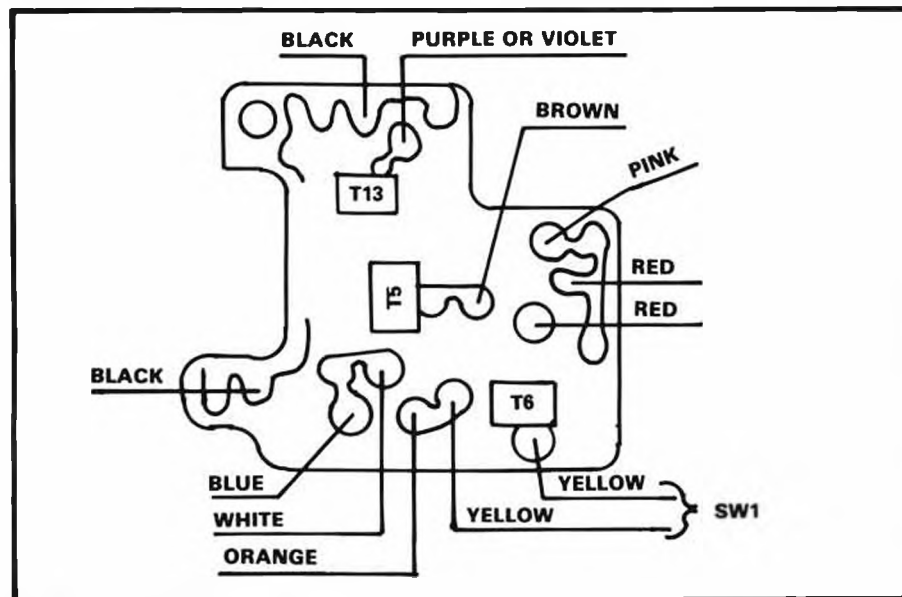

Figure 22 Modified board

film winds onto the take-up spool, it pushes forward a lever inside the take-up chamber. The lever then moves the film-advance indicator from left to right in Fig. 28. You can see the film-advance indicator through the window at the back of the top cover.

Check the film-advance indicator after you replace the retaining ring around the wind shaft, Fig. 24. Reach to the front of the take-up spool and push forward the lever that extends into the take-up chamber; the film-advance indicator

should move into the window. If the film-advance indicator doesn't move, loosen the retaining ring, Fig. 24. Then hold forward the lever inside the take-up chamber so that you can see the film-advance indicator within its window. Continue holding the lever as you tighten the retaining ring.

To replace the wind lever, first hook its hole to the end of the wind-lever return spring. Then rotate the wind lever in a counterclockwise direction as you seat it over the wind shaft. The upper coil of the

wind lever return spring sometimes sneaks under the wind lever. If that happens, the wind lever won't return freely after you replace the cover screw.

The film-speed dial can also be tricky to install. Replace the exposure-compensation lever and the detent rack as shown in Fig. 29; notice that the slot in the exposure-compensation lever fits over the tab on the film-speed resistor ring. Then replace the black plastic decorator ring, Fig. 25. The notch in the decorator ring goes under the exposure-compensation lever.

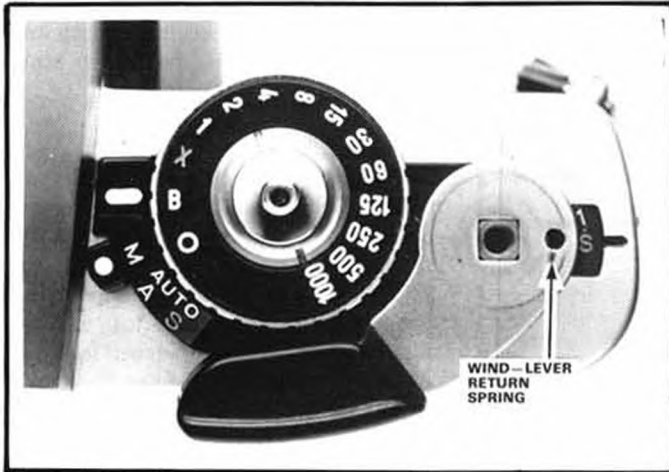

Figure 23

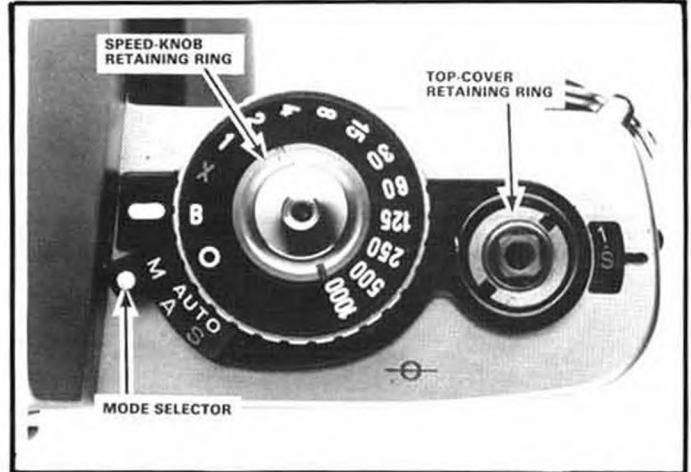

Figure 24

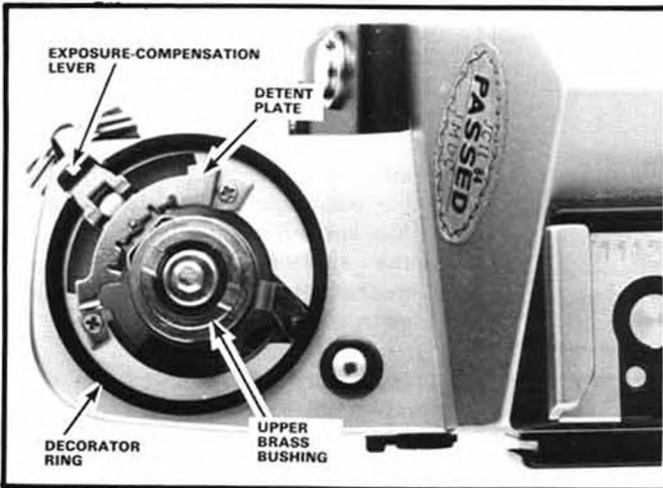

Figure 25



Figure 26

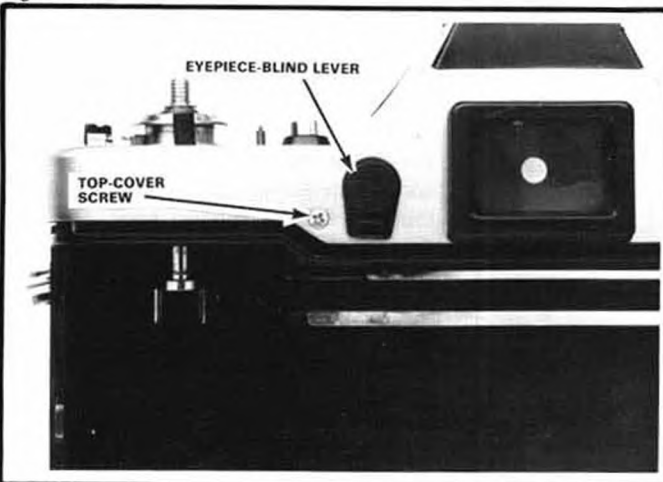

Figure 27

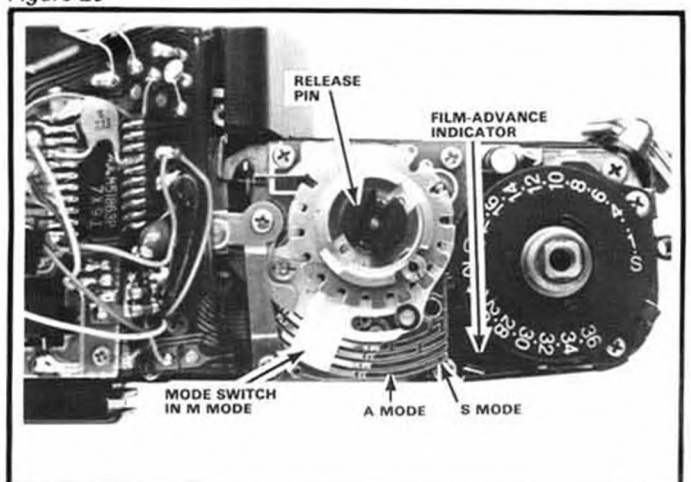

Figure 28

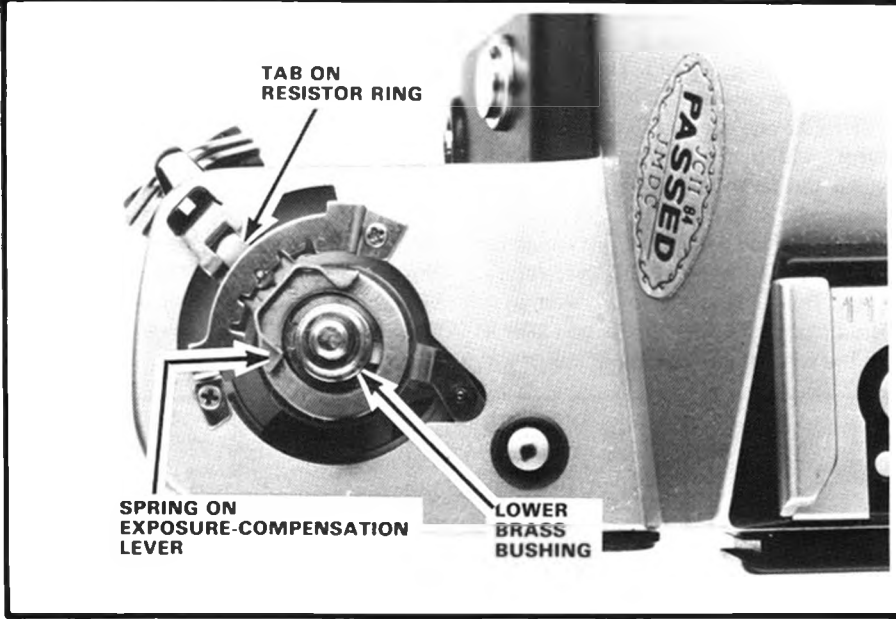

Figure 29

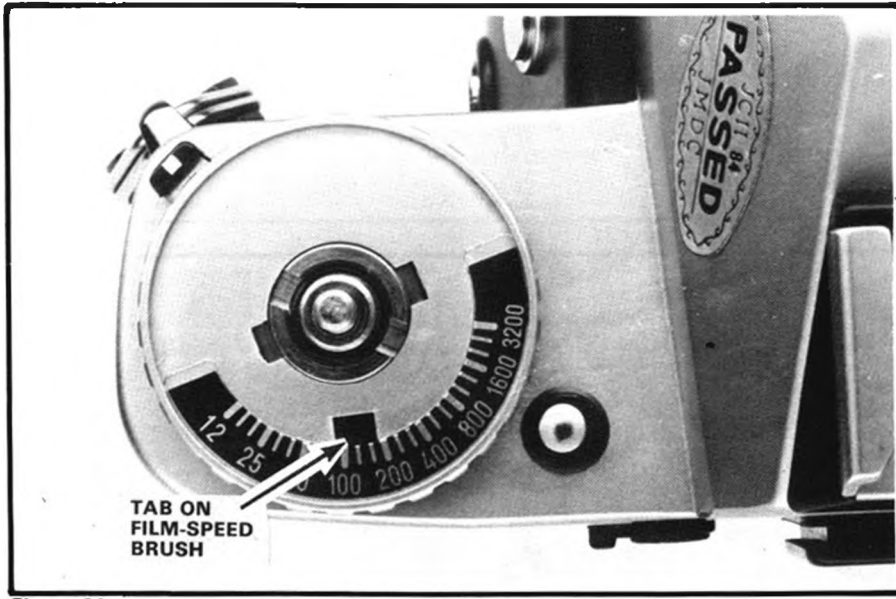

Figure 30

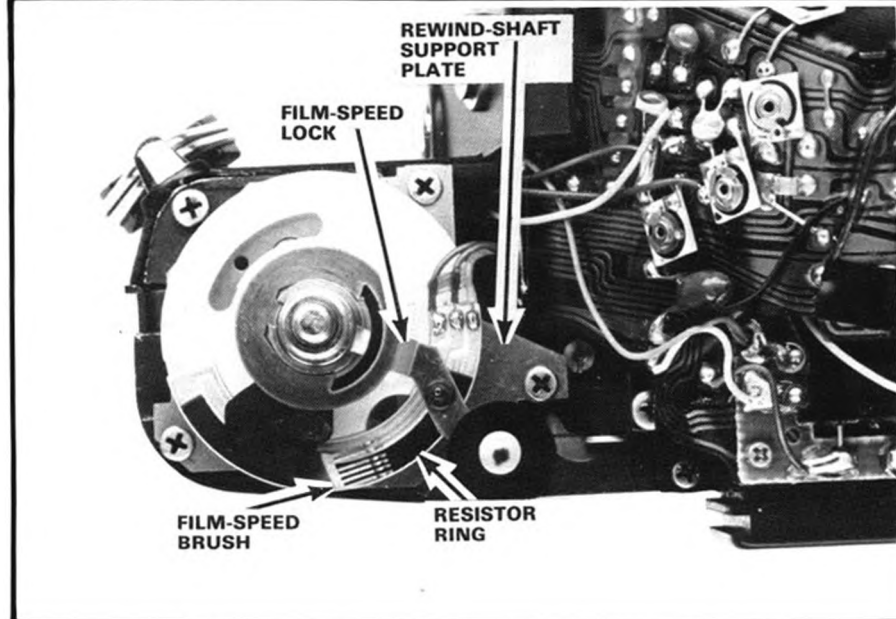

Figure 31

Next seat the upper brass bushing, Fig. 25. Two tabs on the underside of the upper brass bushing fit into the two slots of the lower brass bushing, Fig. 29. Also, the ends of the spring attached to the exposure-compensation lever, Fig. 29, must come against the outer circumference of the upper brass bushing.

Finally, seat the film-speed dial with its slot over the tab on the film-speed brush, Fig. 30. Replace the black plate (the plate with the compensation calibrations) so that the film-speed window is over the film-speed calibrations. Then rotate the black plate until you feel its tab drop into one of the slots in the upper brass bushing.

CHECKING THE FILM-SPEED RESISTOR

With the top cover removed, you can see the parts of the film-speed resistor, Fig. 31. If you know you're going to remove the front-plate/mirror-cage assembly, lift out the film-speed lock, the lower brass bushing, and the film-speed brush. However, if you're troubleshooting or adjusting the camera, reassemble the film-speed dial.

Why? With the film-speed dial removed, the film-speed brush doesn't make firm contact with the resistor ring, Fig. 31. The camera then exhibits the symptoms of an open film-speed resistor:

- only the overrange LED turns on
- the diaphragm always stops down fully in the S mode
- the shutter delivers only the mechanical speed (1/1000 second) in either automatic mode.

Even with the film-speed dial reassembled, there's a trick to setting the film speed. With the top cover removed, neither the film-speed lock nor the exposure-compensation lever keys to anything. You must set both parts in their proper positions before the film-speed setting is valid.

A detent spring on the bottom of the resistor ring provides the click stops for the compensation settings. The detent spring catches one of five detent slots in the rewind-shaft support plate, Fig. 31. First turn the exposure-compensation lever until the detent spring seats in the center slot; that's the "normal" position. The two slots on each side of the "normal" position provide the intentional overexposure and underexposure settings.

Next rotate the film-speed lock to align the "0" compensation calibration with the index on the compensation lever. As long as the "0" calibration remains align-

ed, you can believe the film-speed setting. Naturally, Minolta has a special top cover which holds the film-speed dial in position for tests and adjustments (ASA 100, 0 compensation). But, without the special top cover, you'll have to make sure the parts don't shift out of position.

Fig. 32 illustrates the operation of the film-speed resistor. Setting the film speed moves the film-speed brush along the resistance band; changing the compensation setting rotates the resistor ring. In either case, you're changing the resistance between the blue wire and the gray wire to program the operational amplifier inside IC1.

If you measure the resistance between the purple wire and the gray wire, Fig. 32, you should read the value of the entire resistance band — around 28K. Between the blue wire and the gray wire, you should see the resistance smoothly decrease as you set slower film speeds; the resistance should go from around 28K to around 847 ohms. Here are the resistance values measured from a representative camera for different compensation settings at ASA 100:

+ 1	5.84K
0	9.06K
-1	12.55K

CHECKING THE MODE SWITCH

Before replacing the speed knob, you might take a look at the speed selector and the mode switch at the wind-lever end of the camera, Fig. 33. At the "A" setting, the nut on the mode switch comes against the mask lever. The nut then pushes the mask lever in a clockwise direction. In turn, the mask lever pulls the mask over the window for the shutter-speed indication. Remember, the shutter-speed setting has no meaning in the "A" mode.

The spring-loaded scale to the front of the pentaprism provides the shutter-speed indication, Fig. 34. A tungsten wire couples the shutter-speed scale to the speed selector. Turning the speed selector in a counterclockwise direction draws the tungsten wire from left to right in Fig. 34. The tungsten wire then pulls the shutter-speed scale to the faster-speed calibrations. Notice that you can rotate the wire-hooking nut, Fig. 33, to precisely align the shutter-speed calibrations through the finder.

Certain malfunctions in the electronic operation might lead you to suspect a problem with the mode switch. For example, suppose that there's poor brush contact or dirty contact surfaces. Poor con-

tact at the left-hand side of the brush, Fig. 33, causes the overrange LED to remain on. Also, the shutter delivers only its mechanical speed. Poor contact at the right-hand side causes the shutter to hang open at all modes.

Later models of the camera have a support arm above the mode switch; the support arm maintains firm brush contact.

But, in earlier models, the mode switch should be one of your first suspects. You can pinpoint a problem to the mode switch by using voltage tests. However, you might first replace the speed knob and the wind lever. You'll then be able to troubleshoot most of the electronics in the camera — even though you can't as yet reach all of the actual components.

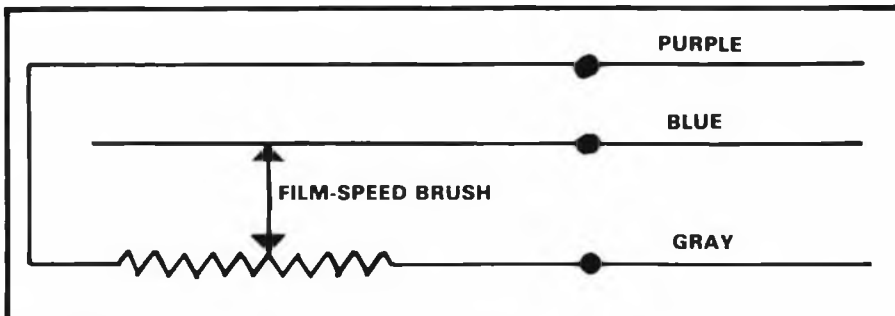

Figure 32

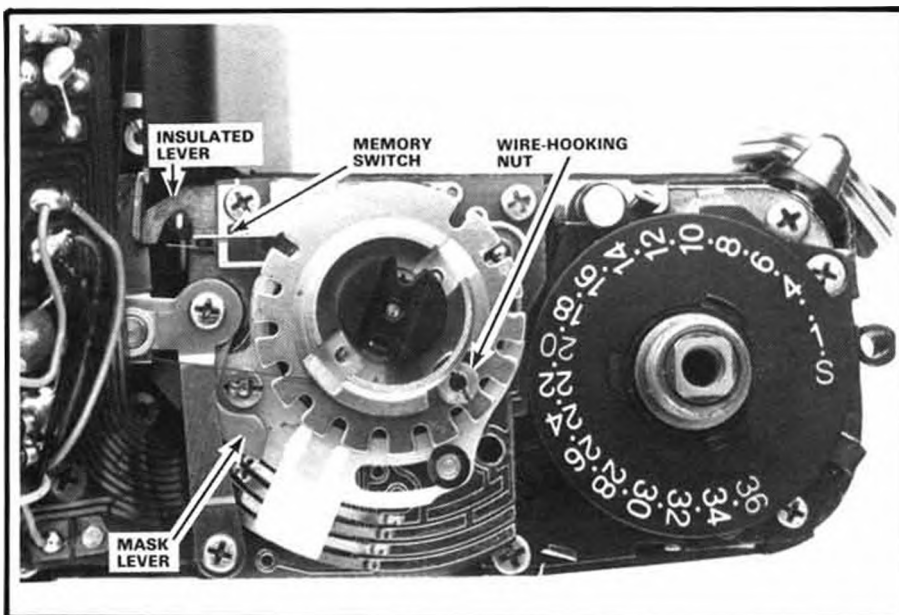

Figure 33

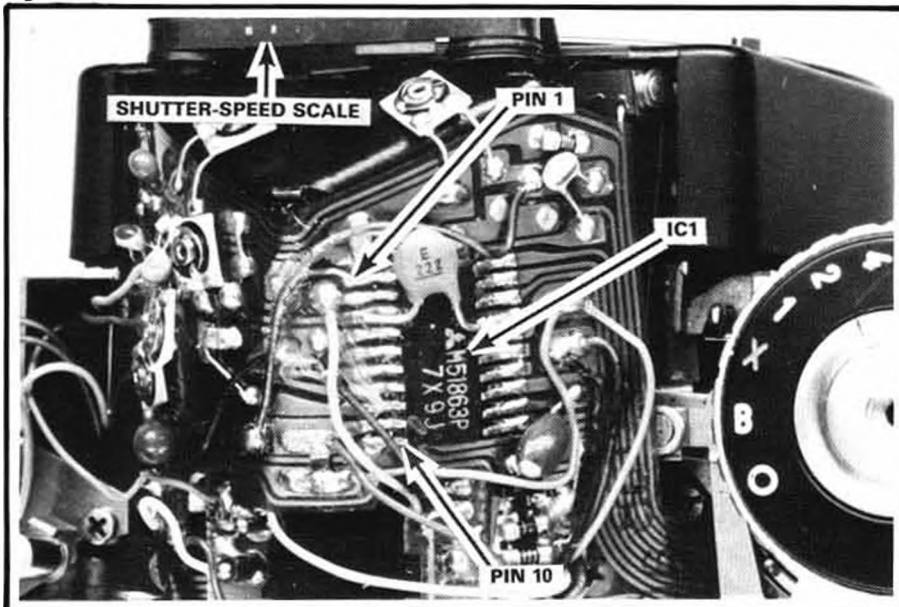

Figure 34

OPERATION OF THE METERING SYSTEM

From the top of the camera, Fig. 34, you can see only one of the three IC's — IC1. The other two IC's mount to the flex circuit at the side of the mirror cage. IC2, as mentioned earlier, controls the viewfinder LEDs. A hybrid IC — H-IC — contains the transistor switching system that links together the various camera functions.

But IC1 does just about everything else in the camera. For one thing, it contains the op amp for the single silicon photodiode (SPD), Fig. 35. Pushing the release button part way closes the metering switch to supply power to the circuit; you should then measure +3V at pin 1 of IC1, Fig. 34. Also, the circuit forward biases the silicon photodiode.

Current through the SPD determines the gate bias of an FET (field-effect transistor), Fig. 36. You can't as yet see the FET in the camera; it mounts to the underside of the flex circuit. The FET then changes the linear current changes through the SPD to linear voltage changes at the amplifier input.

The voltage at the output of the op amp, Fig. 36, now goes more positive as the light intensity increases. This voltage output feeds two circuits — the memory system through IC1 and the LED display through IC2. Besides seeing the output of the op amp, IC2 receives an input from the diaphragm resistor, Fig. 36. Consequently, all three exposure variables — the light level, the film speed, and the f/stop — contribute to the LED readout. At the "S" mode, the minimum-aperture

information also goes to IC2.

IC1 uses the op amp output to charge the memory capacitor, Fig. 35. As the output of the op amp goes more positive, the voltage measured across the memory capacitor increases. So, if you connect a voltmeter across the memory capacitor, you should get a higher reading as you increase the light level or set a faster film speed. Just push the release button part way to charge the memory capacitor.

The charge across the memory capacitor can continue changing as long as the memory switch, Fig. 36, remains closed. Fig. 33 points out the memory switch in the camera. Just before the mirror starts to rise, the insulated lever shown in Fig. 33 drives open the memory switch. Opening the memory switch locks in the memory-capacitor charge.

However, you'll notice in Fig. 36 that the memory-capacitor charge doesn't change with different diaphragm openings. The diaphragm resistor affects only the meter readout; it has nothing to say about the actual exposure time. Yet the exposure-control circuit must know the diaphragm setting in order to program the proper shutter speed.

Unlike most systems, the XD-11 selects the automatic shutter speed by reading the light through a stopped-down aperture. With the diaphragm fully open, the SPD sees the maximum amount of light. The indication circuit for the LED readout must know the selected diaphragm opening in order to display the proper shutter speed at the "A" mode.

Then, when you push the release button the rest of the way, the diaphragm starts closing. As a result, the SPD sees less and less light. Now the voltage output of the op amp decreases (goes less positive) in proportion to the actual diaphragm opening.

The voltage across the memory capacitor also decreases as the diaphragm stops down. Once the diaphragm reaches the proper aperture size, the memory switch opens. Consequently, the charge remains locked in the memory capacitor. The memory-capacitor voltage, modified by the decreasing output of the op amp, reflects all of the exposure variables — the light level, the film-speed setting, and the diaphragm opening.

After the memory switch opens, the mirror starts moving to the taking position. The output of the op amp then drops even more. But the actual metering voltage no longer matters — the memory capacitor has already memorized the reference voltage.

The unique metering action can help in troubleshooting. Since the indication cir-

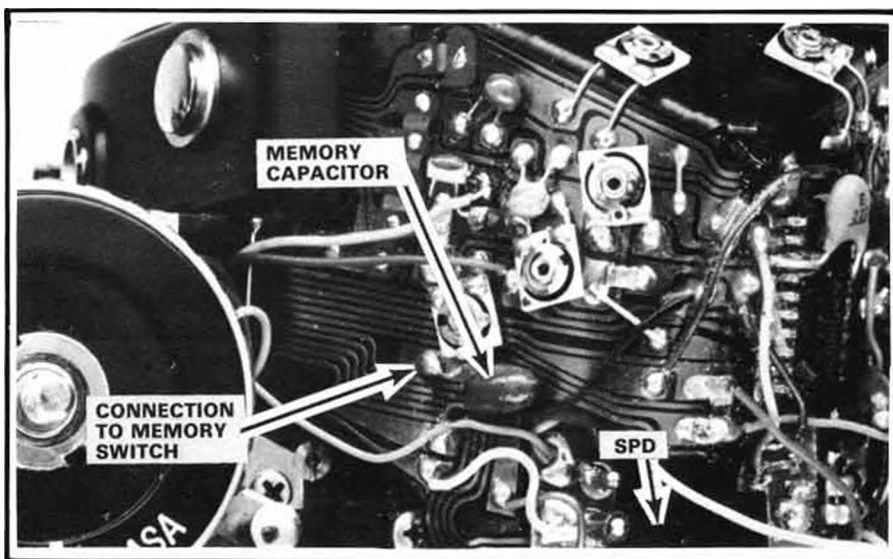

Figure 35

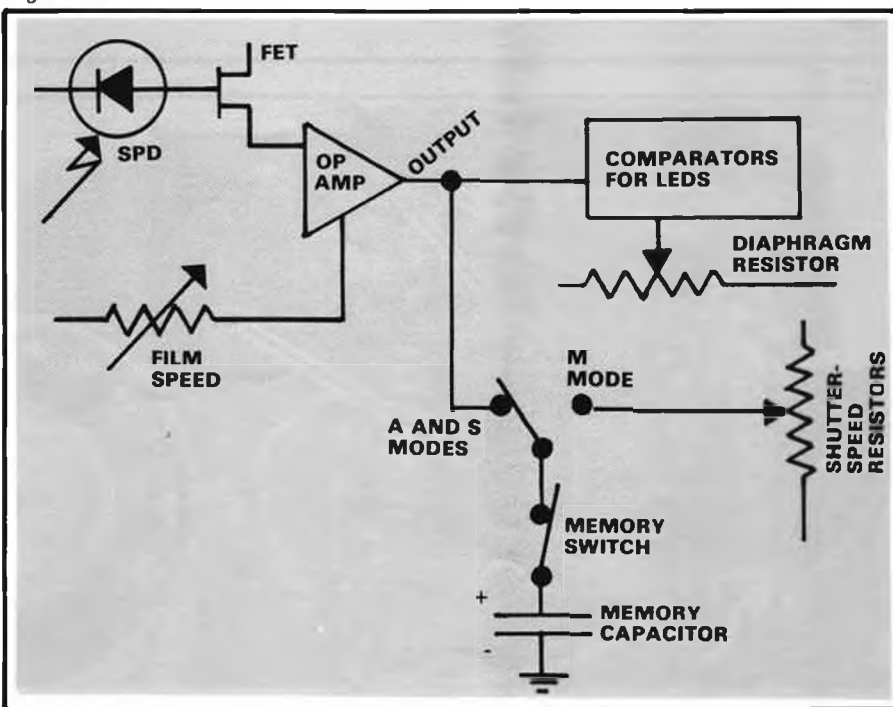

Figure 36

cuit takes its light reading through the largest aperture — and the exposure-control circuit takes its light reading through the stopped-down aperture — the two systems can disagree. For example, suppose there's a problem with the diaphragm resistor. Although the LED indication would then be incorrect, the shutter would still provide the proper exposure.

You can get a better idea of the two separate actions if you operate the camera on "A" with the lens removed. Try rotating the diaphragm-metering ring until the LED display indicates a slow shutter speed. Then release the shutter. You'll find that the shutter delivers an exposure time that's much faster than the readout indicates. Why? You tricked the readout into thinking you'd set a small aperture. But the exposure-control circuit knew better.

At the manually calibrated settings, the meter readout still tells you the proper shutter speed for the light conditions. However, the shutter-speed setting — rather than the op amp — controls the voltage across the memory capacitor. As you set faster shutter speeds, the voltage across the memory capacitor increases.

Earlier, we mentioned the symptom when there's poor contact at one side of the mode switch — the shutter hangs open at all functions. You can see why in Fig. 36. If the mode switch fails to make good contact, the memory capacitor can't charge. Then, since the shutter thinks you're shooting in total darkness, it hangs open.

A defective memory capacitor or poor contact in the memory switch, Fig. 36, results in the same malfunction. In fact, any condition which prevents a reference voltage causes the shutter to hang open. The block diagram of the shutter-speed control circuit, Fig. 37, may make the reason apparent.

The memorized voltage across the memory capacitor provides the base bias for the current-control transistor, Fig. 37. Current through the transistor charges the timing capacitor. With a larger (more positive) base voltage, the transistor conducts harder; it then charges the timing capacitor more quickly.

However, if there's no voltage across the memory capacitor, the transistor won't conduct at all. As a result, the timing capacitor never reaches the voltage which shuts off the electromagnet current. And the shutter stays open.

Fig. 37 also shows the electromagnet current path. Consider that you've just completed the release-button stroke to release the shutter. As you've seen, switch S7 remains closed until the mirror-release combination magnet M2 repels its

armature. With S7 closed, the switching transistor, Fig. 37, turns off; the base of the transistor connects to ground.

With the switching transistor turned off, 0V appears at each lead of the electromagnet. Then, when the mirror releases, S7 opens and applies a positive voltage to the transistor base. The switching transistor now turns on, connecting the red electromagnet lead to +3V.

The holding current flows from the electromagnet current source, Fig. 37, through the coil, and through the transistor to the positive side of the supply. Now the energized electromagnet holds the closing blade to keep the shutter open. The current source continues feeding current to the electromagnet until the timing capacitor charges.

But the timing capacitor can't start charging until the trigger switch (timing switch) opens, Fig. 37. As long as the trigger switch remains closed, the current-control transistor won't conduct. The trigger switch closes when you cock the shutter. Then, when the opening-blade assembly starts to move, it opens the trigger switch.

Now the expansion circuit feeds current to the emitter of the current-control transistor, Fig. 37. And the transistor turns on, conducting the current that charges the timing capacitor. The higher the memorized reference voltage, the more quickly the timing capacitor reaches the voltage which shuts off the electromagnet current source.

Fig. 38 shows the voltage measured

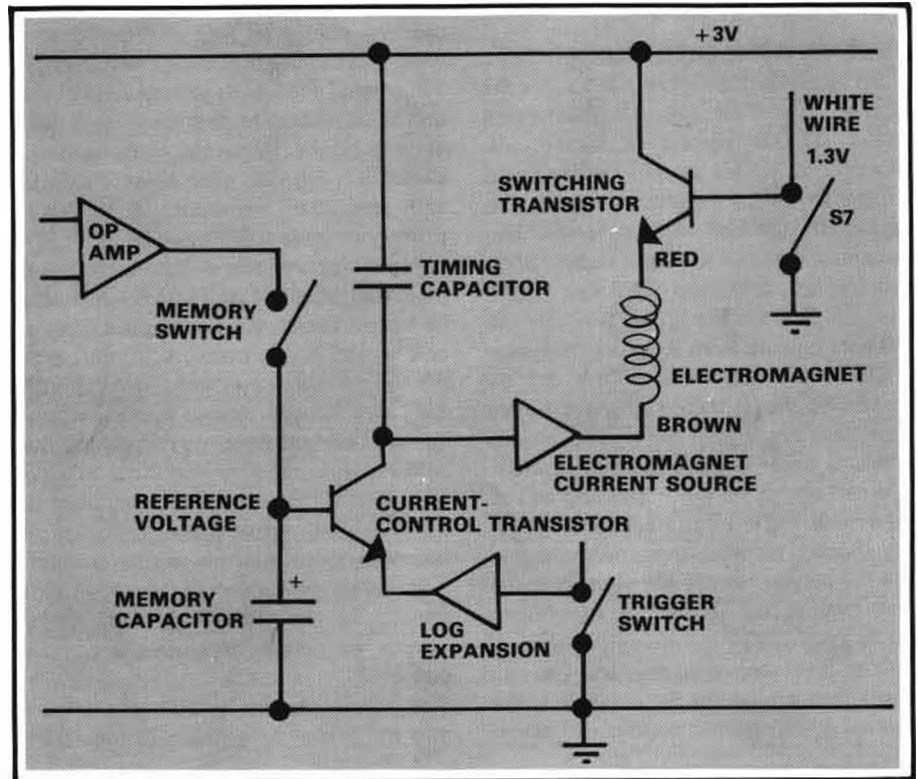

Figure 37

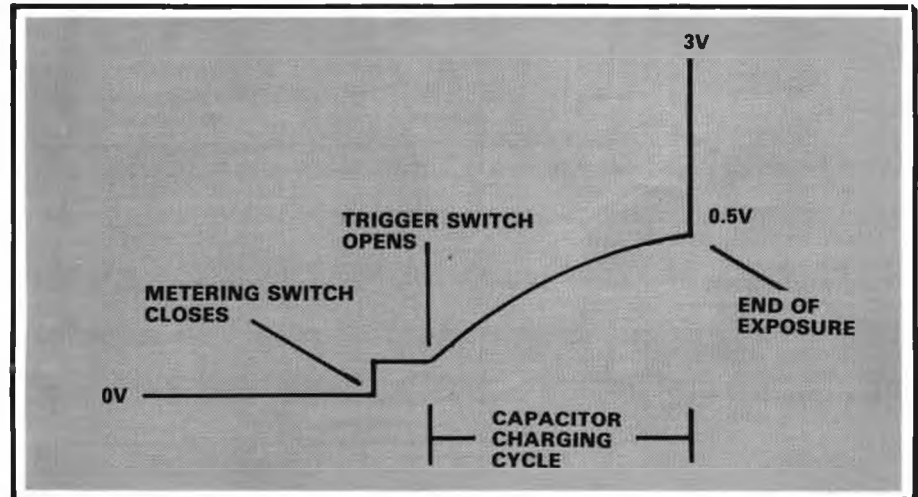

Figure 38

across the timing capacitor. When you push the release button far enough to close the metering switch, a slight voltage appears across the timing capacitor. However, the timing capacitor can't charge any further until the trigger switch opens. Opening the trigger switch then allows the timing capacitor to charge as shown in Fig. 38. When the timing capacitor reaches around 0.5V, it shuts off the current through the electromagnet to end the exposure.

You can't as yet reach most of the components shown in Fig. 36 and Fig. 37. But you can often pinpoint the problem from the top of the camera. So, before covering the complete electronic operation, let's run through the techniques you can use to check the switches and the electromagnet without disassembly.

CHECKING THE ELECTROMAGNET

An open electromagnet coil causes the shutter to deliver only its mechanical speed (1/1000 second or faster). Although you'll have to remove the Seiko shutter to replace the electromagnet, you can check the coil without further disassembly. Remove the small section of insulating tape at the top of the flex circuit. You can now see the brown wire and the red wire coming from the electromagnet.

Check the continuity of the coil by measuring the resistance between the red wire and the brown wire. You should measure around 300 ohms. Alternately, you can perform a quick shorting test to determine if the electromagnet is good. Try shorting between the brown wire and ground as you release the shutter. If the coil is good, the shutter will hang open for as long as you maintain the short.

With most electronic shutters, you can check coil continuity by measuring the voltage at each electromagnet lead. If you

measure a voltage at one lead but not at the other, the coil must be open. However, you've seen that the transistor in series with the XD-11 electromagnet remains off until you release the shutter. So, at the red electromagnet lead, you'll measure 0V — not the full battery voltage as you would with most other circuits. You'll also measure 0V at the brown lead.

When you release the shutter, the transistor turns on and connects the red electromagnet lead to positive battery, Fig. 38. So, with the shutter open, you should measure 3V at the red wire, Fig. 39. But you should still measure 0V at the brown wire. The brown wire now connects to 0V, keeping a 3V potential difference across the electromagnet.

The voltage at the brown wire switches high to end the exposure. If you leave the positive voltmeter lead on the brown wire, you can see the voltage switch high. You should see a voltage indication at the end of the exposure. But the voltage only appears briefly. When the mirror returns, switch S7, Fig. 38, once again opens to shut off the transistor. Both electromagnet leads then return to 0V.

A poor ground connection in the circuit may also cause the shutter to deliver only its fastest speed. Suspect a poor ground connection if you measure a voltage at the red electromagnet lead when you partially depress the release button. If you measure around 2.5V, try retouching the solder connections to the black ground wire, Fig. 39. However, you may have to remove the front-plate/mirror-cage assembly to correct the ground contact. A screw on the section of flex circuit that mounts to the mirror cage makes the ground connection through the camera body.

If you measure the full 3V to the red wire and the brown wire, the switching tran-

sistor may be shorted, Fig. 38. A 3V reading could also indicate a problem with the electromagnet current source. Both components are inside H-IC, the hybrid IC on the side of the mirror cage. You'll have to remove the front-plate/mirror-cage assembly to replace the IC.

CHECKING THE METERING SWITCH AND THE RELEASE SWITCH

Both the metering switch and the release switch are at the back of the front-plate assembly. As yet, you can't reach the switches. But you can reach the switch connections for troubleshooting. The metering switch connects to the green wire, and the release switch connects to the orange wire, Fig. 39.

Fig. 40 shows the portion of the schematic that includes the two switches. As you start pushing the release button, the metering switch S5 closes. The metering switch turns on transistor T1, applying the positive battery voltage to pin 1 of IC1 and to pin 2 of IC2.

Pushing the release button the rest of the way closes the release switch S3. The release switch now tells the electromagnetic release circuit to release the mirror. Also, the power-holding circuit — transistor T11 in Fig. 40 — turns on. T11 now keeps transistor T1 conducting. So, even if you allow the release button to return, the circuit continues to operate.

Transistors T1 and T11 are both inside H-IC on the side of the mirror cage. Diode D2, a transistor connected as a diode, Fig. 40, is also inside the hybrid IC. You might suspect a problem in this portion of the circuit if the camera draws power constantly — even though you haven't depressed the release button.

What if the metering switch S5 fails to make contact? Obviously, the LEDs will not turn on when you partially depress the release button. Yet, thanks to the power-holding circuit, the LEDs will turn on when you fully depress the release button. With a defective release switch S3, the shutter won't release at the electronically controlled settings.

To check the metering switch, measure the voltage at the green wire, Fig. 39. You should measure around 2.5V. When you depress the release button part way, you should measure 0V at the green wire. If the voltage doesn't drop to 0V (ground), the metering switch isn't making good contact.

Alternately, you can check the metering switch by connecting an ohmmeter between the green wire and ground; you should measure direct continuity when you push the release button part way. Or you can simply short the green wire to ground. Connecting the green wire directly

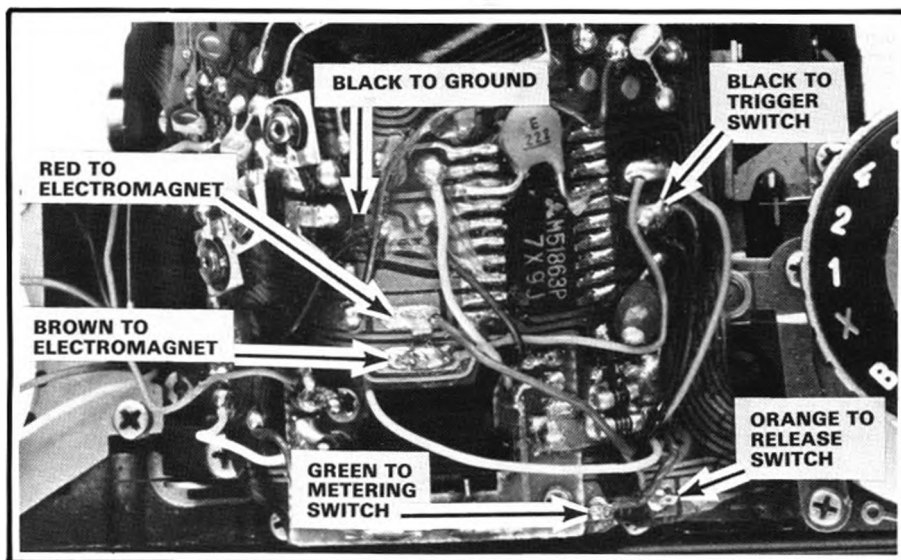

Figure 39

to ground should turn on the LEDs.

If the LEDs turn on during your shorting test, the problem must be in the metering switch. However, if the LEDs still won't turn on, the problem is in the circuit. Suppose, for example, that you measure 0V to pin 1 of IC1 while you're shorting the green wire to ground. Suspect a problem with H-IC; transistor T1, apparently isn't turning on.

Use similar techniques to check the release switch. But remember — the release switch only closes at the electronically controlled speeds. Use any speed-knob setting except bulb or the mechanical 1/100 second. Then measure the voltage to the orange-wire connection, Fig. 39. You should measure 2.5V until you fully depress the release button; the voltage should drop to 0V with the release button depressed.

You can also use a shorting test to check the release switch. Shorting the orange wire to ground should release the shutter. If your shorting test doesn't release the shutter, IC2 may be the problem.

CHECKING THE TRIGGER SWITCH

Like the electromagnet, the trigger switch is a shutter part. The trigger switch should close when you cock the shutter. When the shutter releases, the trigger switch should open to initiate the exposure.

If the trigger switch remains closed, the shutter will hang open. If the trigger switch fails to close or makes poor contact, you won't be able to bring in your

shutter-speed adjustments — especially the fast speeds. Erratic shutter speeds may also result from poor contact in the trigger switch.

The trigger switch connects between the black wire, Fig. 39, and ground. Check the continuity between the black wire and ground with the shutter cocked; you should measure direct continuity, indicating that the trigger switch is closed. Then release the shutter. You should now measure no continuity — an open — between the black wire and ground.

CHECKING THE MEMORY SWITCH

Poor contact in the memory switch normally causes the shutter to hang open. With most cameras, you must perform major surgery to reach the memory switch. But, in the XD-11, you need only remove the top cover to clean the memory switch and check the continuity.

The blade of the memory switch that's closer to the back of the camera connects to the memory capacitor and to pin 10 of IC1, Fig. 34. You can check the memory switch by measuring the voltage to pin 10 with the release button partially depressed; you should measure around 0.5V. If the memory switch isn't making good contact, you'll measure 0V at pin 10.

Or you can measure the continuity between the front blade of the memory switch, Fig. 33, and the memory capacitor, Fig. 35. You should measure direct continuity. With the shutter held open on bulb, you should measure no continuity.

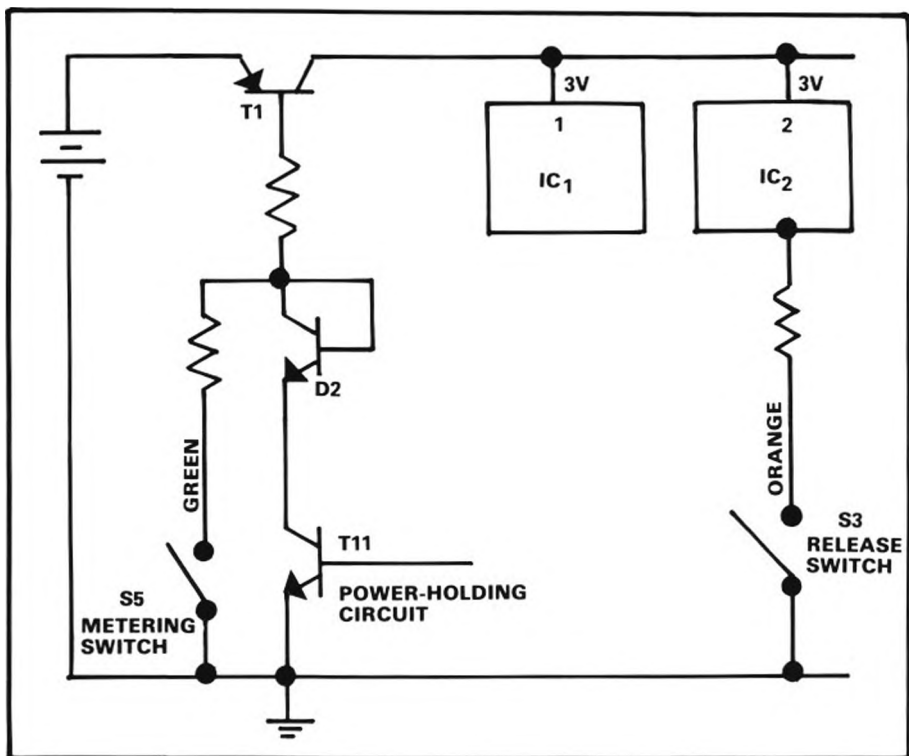

Figure 40



minolta XD 11

SCHEMATIC OF THE XD-11

It may at first appear that the complete schematic, Fig. 41, shows only two of the three IC's. However, the circled numbers indicate the connections to the third IC — that's H-IC, the hybrid IC on the side of the mirror cage. All the parts enclosed by the dotted line are inside H-IC.

The schematic shows all the components inside H-IC. It also gives you a good indication as to the components inside the other two IC's. Such detailed information can be especially helpful in troubleshooting. No, you can't take apart an IC to repair the innards. But you can tell what kinds of signals should appear at the IC pins.

For example, the large triangle inside IC1 indicates the amplifier for the silicon photocell (SPC in the schematic). The connection at pin 19 charges the memory capacitor C2. You then know at a glance that the voltage at pin 19 should go more positive as you increase the light striking the SPC.

The center triangle inside IC1 is the comparator for the diaphragm-control circuit. When the output of the comparator switches low, it turns on transistor T13. T13 then switches on T5. Now C5 discharges through the diaphragm-control magnet M2 to arrest the diaphragm closure.

At pin 16 of IC1, another comparator provides the switch for the closing-curtain electromagnet M3. When the comparator output at pin 16 drops low, current flows through M3 to hold

open the shutter. The voltage at pin 16 goes high to shut off the electromagnet current.

Inside IC2, you can see the large triangle which represents the individual comparator stages for the LEDs. The cathode of each LED connects to a comparator output. Notice that the anodes of the LEDs connect to +3V when transistor T1 turns on. Each LED then has the anode bias it needs to conduct. As soon as the cathode of a particular LED switches low, current can flow through that LED.

The small comparator inside IC2 — the one connected to pin 3 — provides the release lock. When the release switch S3 closes, the comparator compares the battery voltage with a reference voltage. Then, providing there's sufficient power for proper operation, the comparator switches low. The low voltage at pin 3 forward biases transistor T6 to release the mirror. Another triangle inside IC2 represents the analog-to-digital converter which lights the "60" LED when the flash unit charges.

As yet, you can only reach one IC for voltage tests — IC1 at the top of the camera. However, you'll be able to check H-IC after you remove the front-plate/mirror-cage assembly. So, before going through the rest of the electronic operation, we'll describe the procedure for separating the front-plate/mirror-cage assembly from the body casting.

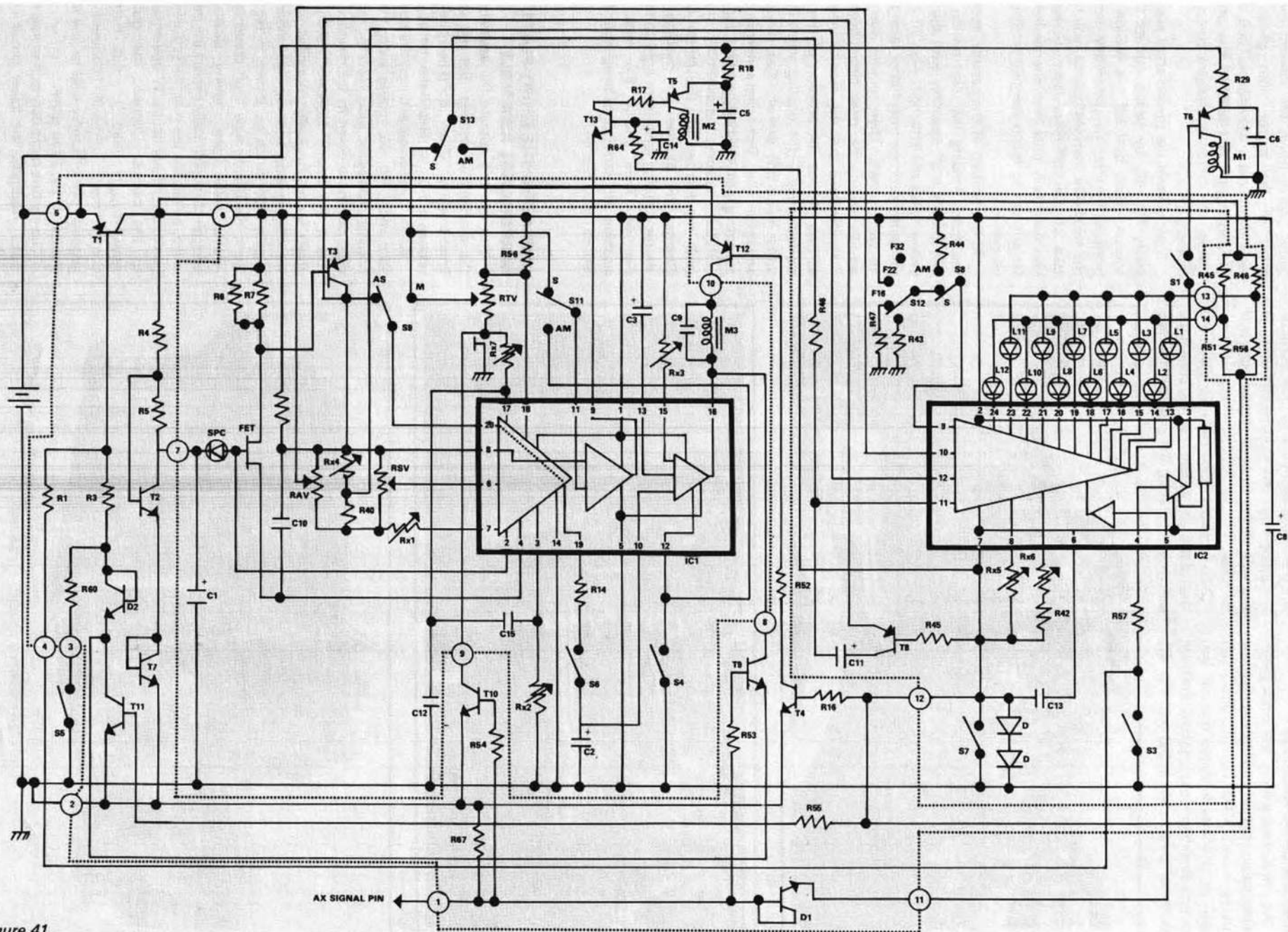

Figure 41

REMOVING THE FRONT-PLATE/ MIRROR-CAGE ASSEMBLY

As mentioned earlier, the front plate, mirror cage, shutter, and flex circuit come out as a unit. What's more, you don't have to unsolder a single wire. If you haven't already done so, remove the front decorator plate; a slit at the top, Fig. 42,

allows you to slightly spread the sides of the front decorator plate to clear the lens-mounting ring. The stop-down button at the side of the front-decorator plate will be loose.

The small plate you can now see at the side of the lens mount, Fig. 43, covers the air-damping piston; the plate simply clips

into place. In action, the air-damping piston slows down the upward movement of the mirror; that gives the diaphragm time to stop down. Then, after the diaphragm has reached the proper f/stop, the mirror mechanism opens the memory switch.

Now remove the rewind-shaft support plate, Fig. 42, by taking out its three screws. Then peel off the rewind-side front leatherette. To completely remove the wind-side front leatherette, you must take off the self-timer lever. However, you need only peel back the leatherette far enough to reach the two front-plate screws.

At the bottom of the camera, remove the screw holding the reset switch S1. Lift aside the S1 assembly with the two yellow wires still attached. Also lift aside the battery compartment after taking out its two screws. Then remove the two screws holding the lower circuit board.

Finally take out the four front-plate screws. Notice the position of the one slotted screw — the locating screw in the upper wind-side corner. You can now separate the front-plate/mirror-cage assembly from the body casting, Fig. 44.

Before replacing the assembly, charge both the shutter and the mirror cage. Charge the shutter by pushing the shutter-cocking lever from right to left in Fig. 44. Then charge the mirror by pushing the mirror-tensioning lever from left to right, Fig. 44.

OPERATING THE FRONT-PLATE/ MIRROR-CAGE ASSEMBLY

You can still operate the assembly at the mechanical settings. Set the speed knob to either "0" or "B." Then push the release button to release the mirror.

At the mechanical settings, the release-slide latch, Fig. 45, moves away from a notch in the release slide. Now the release slide can move down its full distance and release the mirror. However, when you select an electronically controlled speed, the release-slide latch swings under the release-slide notch as shown in Fig. 46. Here, the release-slide latch prevents the release slide from moving down far enough to mechanically release the mirror.

So, to release the mirror electronically, you'll have to connect a 3V power supply to the circuit. Connect the positive power-supply lead to the battery-compartment terminal; connect the negative power-supply lead to any metal portion of the front plate.

There's one more connection you must make. Normally, the lower circuit board makes its ground connection through the body casting. But now, with the lower cir-

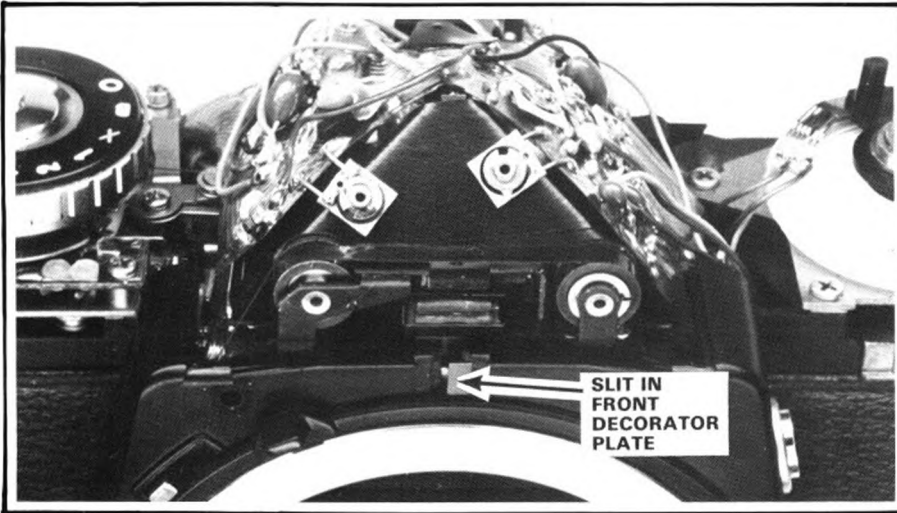

Figure 42

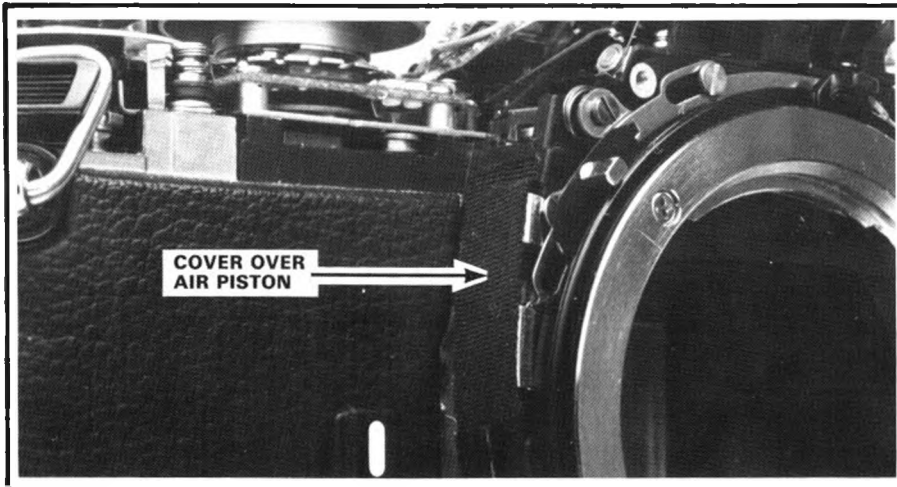

Figure 43

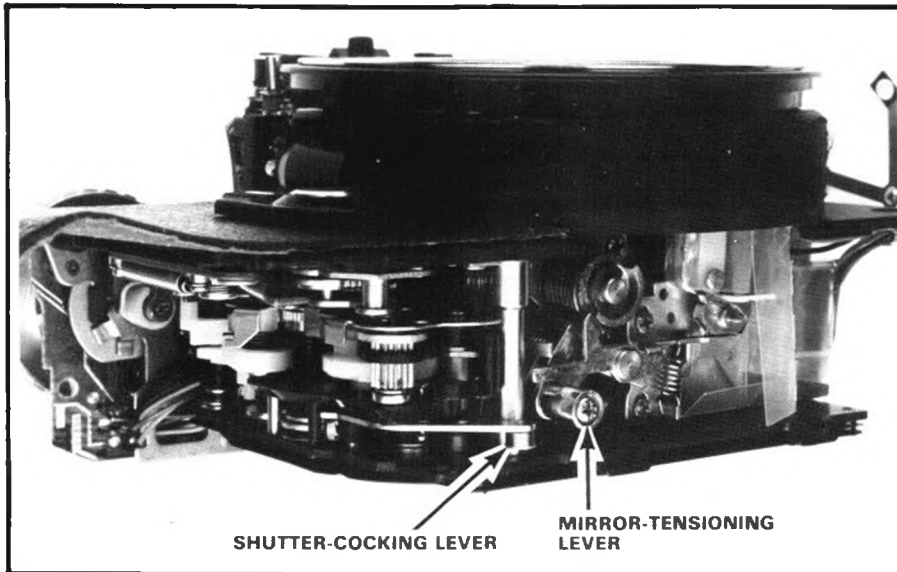

Figure 44

circuit board removed, you must provide the ground. Connect a jumper between the ground land on the lower circuit board, Fig. 47, and the front plate. The shutter should then operate electronically.

Connecting the power supply also allows you to check the voltages to H-IC, Fig. 48. The two variable resistors you can see in Fig. 48 provide the adjustments

for the LED readout. However, you should avoid disturbing these adjustments. Why? Because you must remove the front-plate/mirror-cage assembly to reach the variable resistors.

The Minolta service manual does describe a special tool for adjusting the LED readout — a dummy camera body which has a special cutout over the

variable resistors. But, according to Minolta, the dummy camera body isn't available. You can't even make your own by purchasing a replacement body casting; the body casting is the one part in the XD-11 which Minolta doesn't supply.

An XD-11 that's beyond economical repair may then be worth purchasing; you can use the body casting to make the special tool. But, in most situations, you won't have to adjust the two variable resistors anyway. If the other adjustments are correct, the LED readout should also be correct. We'll describe the adjustment sequence a little later. For now, just remember to avoid disturbing the two variable resistors on the side of the mirror cage.

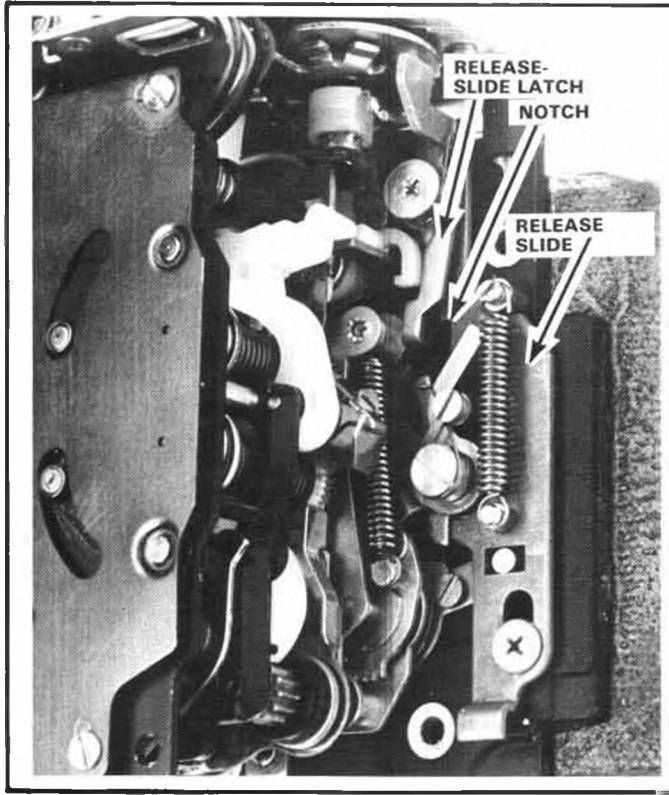

Figure 45 Mechanical setting

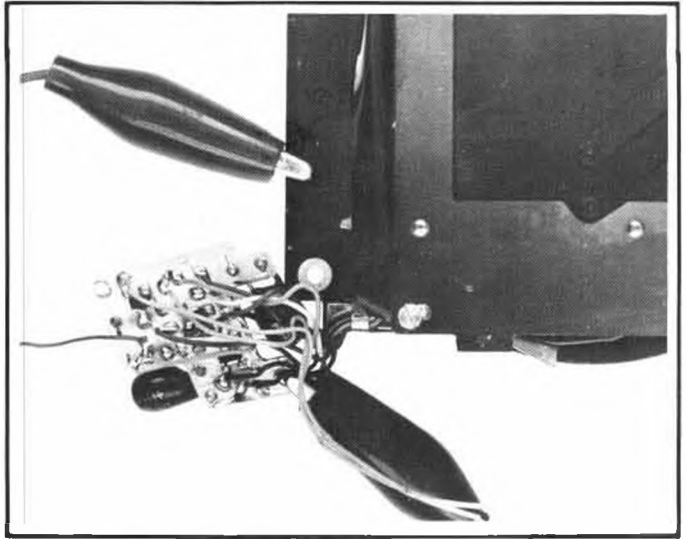

Figure 47 Ground jumper connected

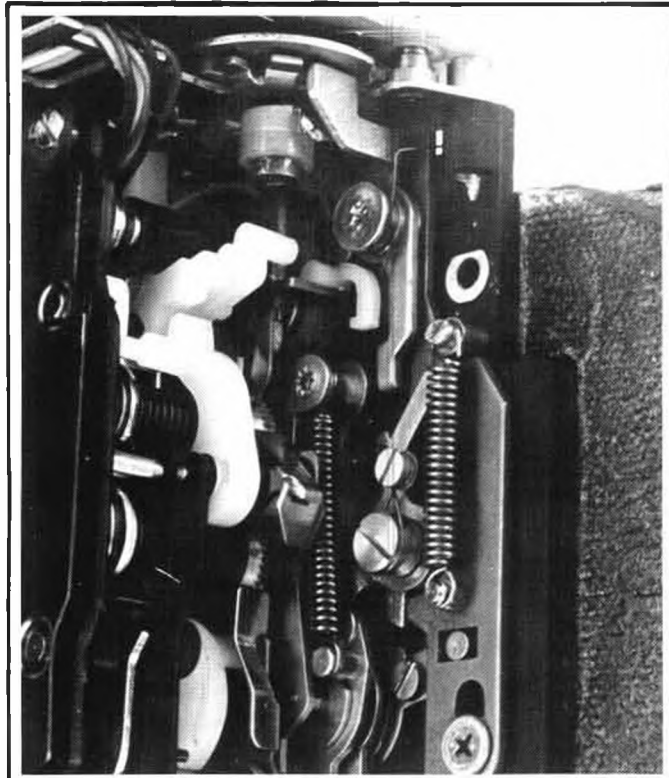

Figure 46 Electronic setting

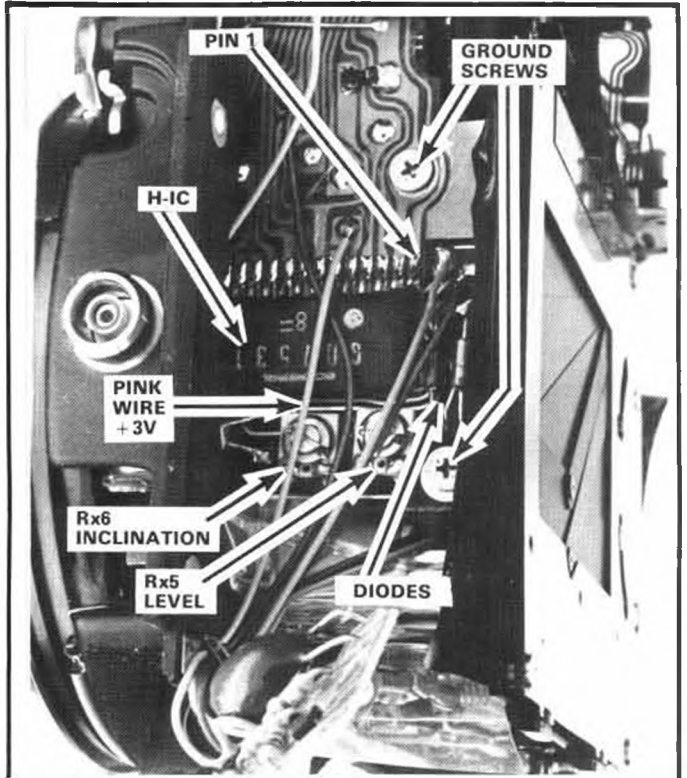

Figure 48

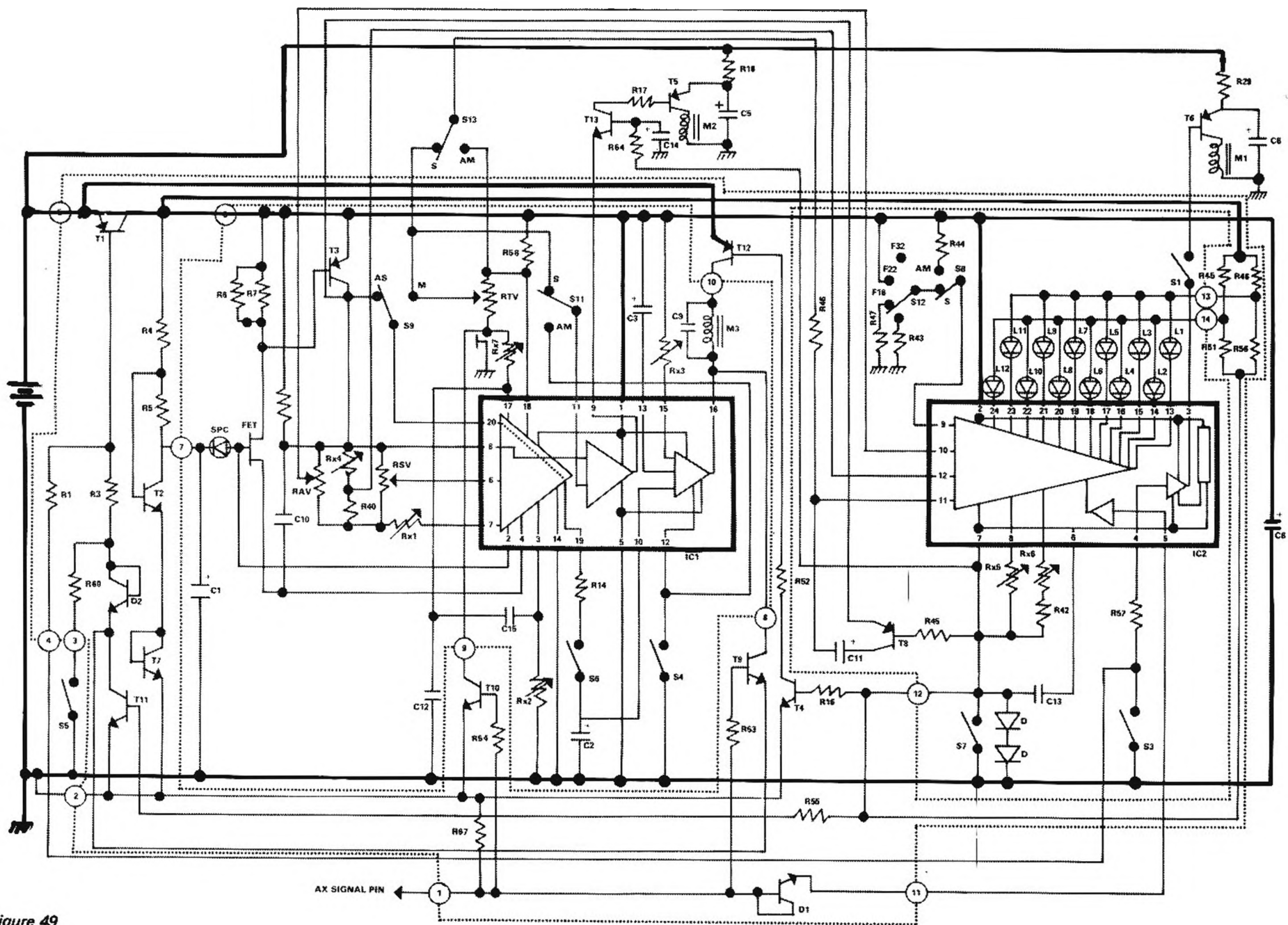

Figure 49

CHECKING H-IC

You might suspect H-IC, Fig. 48, if nothing works electronically — the LEDs won't turn on and the shutter won't release. Also suspect H-IC if you're getting battery drain without depressing the release button part way. The customer then complains that the batteries don't last.

H-IC supplies the power to the other two IC's. When you push the release button far enough to close the metering switch S5, transistor T1 turns on, Fig. 49. The +3V signal then appears at pin 6 of H-IC, the collector of T1.

So, with the release button partially depressed, you should measure close to 3V at pin 6 of H-IC (actually, the power-supply voltage minus the drop across T1). You should also measure 3V at pin 1 of IC1, Fig. 50.

If you don't get the 3V signal at pin 6 of H-IC, check the voltage at pin 5. Notice in Fig. 49 that pin 5 connects directly to the positive side of the supply. Consequently, you should measure the full power-supply voltage at pin 5 — even without depressing the release button. If not, check the battery connections and the pink wire that runs from the lower circuit board to pin 5 of H-IC, Fig. 48.

Notice in Fig. 49 that the full power-supply voltage always appears at the two release capacitors — C5 for the diaphragm-control system and C6 for the mirror-release system. You should then measure 3V across each capacitor regardless of the release-button position. The power-supply voltage also connects directly to the emitter of T12, the transistor in series with the shutter's electromagnet.

However, at the collector of T12 — pin 10 of H-IC — you should measure 0V. The voltage at pin 10 should switch to nearly 3V with the shutter open. Transistor T12 then turns on, conducting current through the coil of M3.

Fig. 51 shows the remaining pin voltages of H-IC. The voltage at pin 7 provides the cathode bias for the SPC. This voltage is the sum of the voltage drops across two transistors connected as diodes — T2 and T7, Fig. 49. A forward-biased diode provides an effective voltage regulator; its voltage drop remains constant at around 0.6V, despite changes in current. So, with two diodes in series, the voltage at pin 7 should remain constant at approximately 1.2V. The filter capacitor C1 helps maintain the constant reference voltage.

The 1.2V reference connects to the cathode of the SPC, Fig. 49 and Fig. 50. Here, the voltage should remain constant — despite changes in the light level. But the voltage at the anode of the SPC

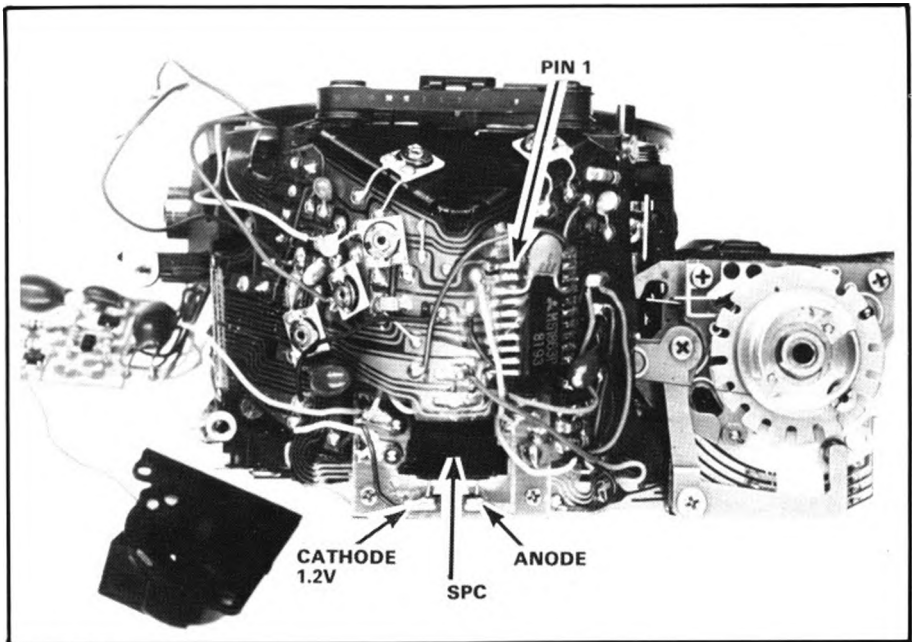

Figure 50

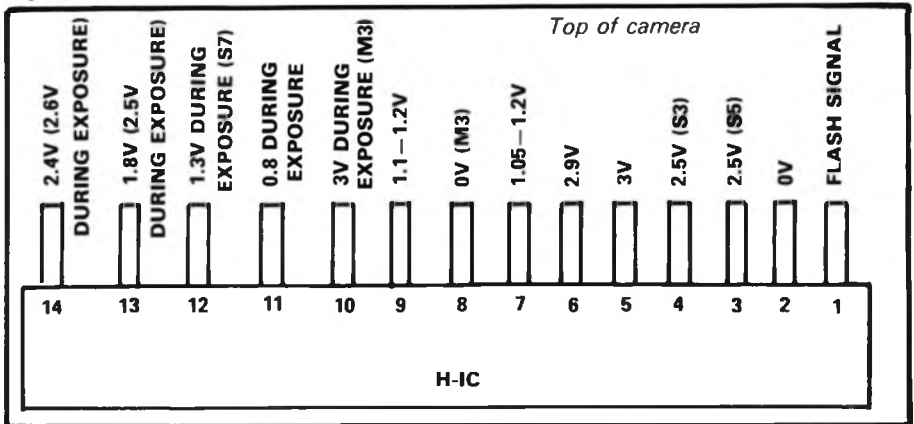

Figure 51

should go more positive as the light level increases. The anode voltage provides the gate bias for the FET, Fig. 49.

In effect, the FET takes the linear current changes through the SPC and converts them to linear voltage changes which drive the amplifier. A silicon photodiode does put out its own voltage. But the voltage changes across a silicon diode aren't linear with respect to light-level changes; rather, the voltage change is the log of the light-level change. The FET then performs logarithmic expansion. Voltage changes at the output of the FET match the light-level changes in linear fashion.

The op amp inside IC1 now takes the input from the FET and provides an amplified output at pin 19, Fig. 49. Notice that the memory capacitor C2 connects to pin 19 through the closed memory switch S6. With the memory switch closed, the memory capacitor then charges to the pin 19 voltage. The voltage at pin 19 goes more positive as the light level increases.

You should now be able to visualize the symptoms which could result from a

defect in H-IC. Suppose, for example, that the LEDs don't turn on when you depress the release button part way. You then check the voltage at pin 6 of H-IC. If you measure 0V at pin 6 — but you get 3V at pin 5 — suspect the metering switch S5 and transistor T1, Fig. 49.

Earlier, we described one way to check the metering switch at the top of the camera. You can also check the metering switch at H-IC, Fig. 49. Shorting pin 3 to ground should turn on the LEDs. If so, you know that H-IC must be o.k.; the problem must be with the metering switch or the wiring. But, if the LEDs still won't turn on, you'll probably have to replace H-IC.

We also mentioned another possibility — the camera constantly draws current, causing excessive battery drain. Try measuring the voltage at pin 6 without depressing the release button. If you measure close to 3V, transistor T1 may have an internal short. Or the power-holding circuit — T11 and D2, Fig. 49 — may be keeping T1 turned on. Either way, replace H-IC.

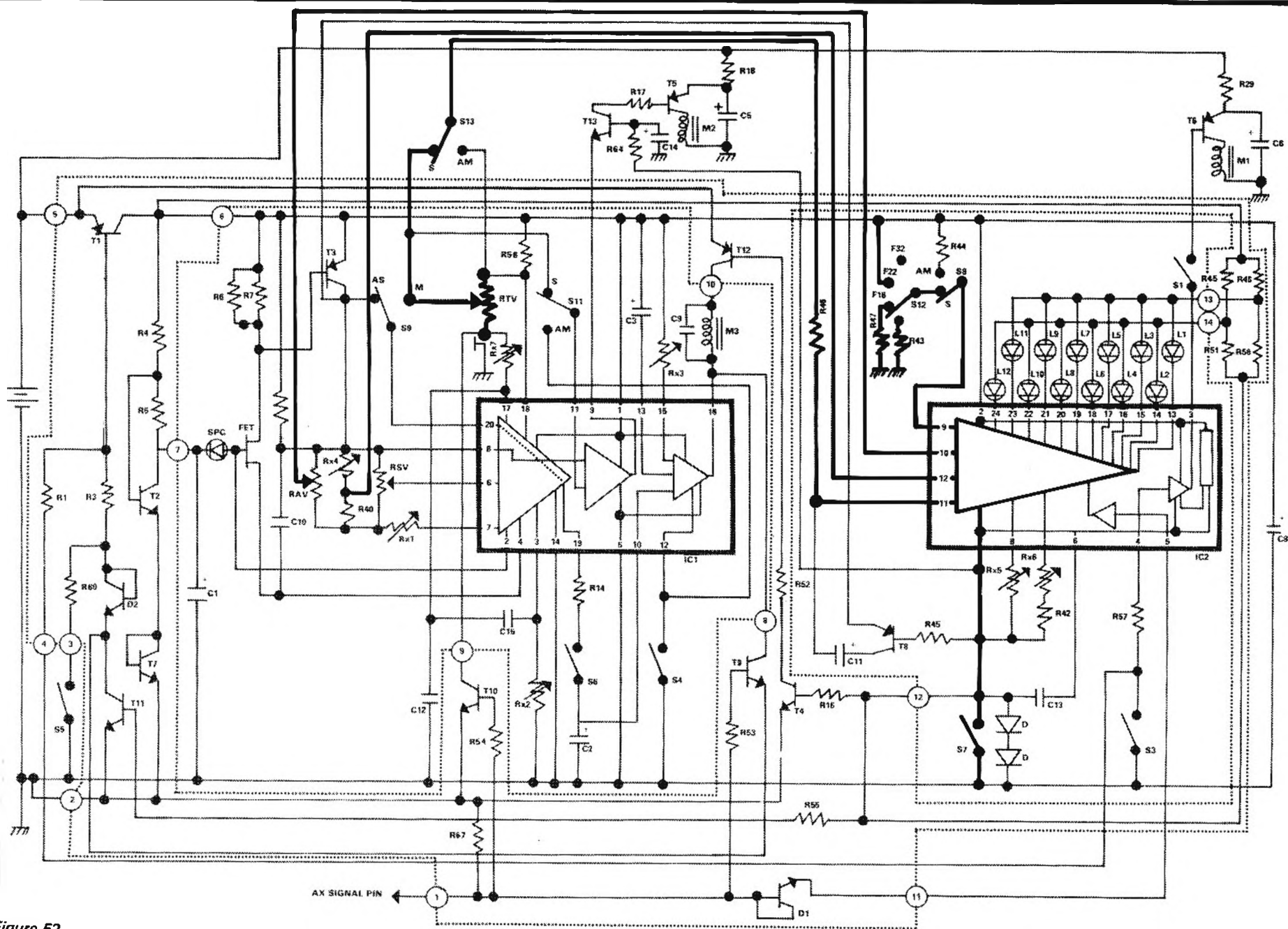

Figure 52

CONNECTIONS TO THE LED READOUT CIRCUIT

Even with the mirror cage removed, you can't reach IC2; the driver for the LEDs mounts to the other side of the flex circuit, Fig. 48. However, you can make most of the tests without further disassembly.

At the A and M settings, IC2 considers four values — the shutter-speed setting, the film-speed setting, the diaphragm setting, and the light level. It then turns on the appropriate shutter LED to indicate the corresponding shutter speed.

You can follow the connections in Fig. 52. The diaphragm information (AV) appears at pin 10 of IC2. At pin 12, IC2 receives the light-level (BV) and film-speed (SV) information. The shutter-speed information (TV) from the shutter-speed resistor RTV goes to pin 11.

When you select the S mode, IC2 also receives the minimum-aperture information at pin 9. Switch S12 at the front of the camera, Fig. 53, selects a resistance value according to the minimum aperture of the lens. With no lens installed, notice that the S12 brush rests at the center of the first resistance path, Fig. 53. Installing the f/16 MD lens set to the smallest aperture moves the brush to the second resistance path — the resistor labeled R47 in Fig. 52.

The f/22 lens moves the brush to the third resistance path; here, the S12 brush connects pin 9 of IC2 directly to positive battery, Fig. 52. With the f/32 lens, the brush moves off the resistors to an open portion of the board.

Notice in Fig. 52 that the part of the mode selector labeled S8 connects the minimum-aperture switch S12 to pin 9 at the S setting. Then, with the release button partially depressed, you should measure a voltage at pin 9 — a voltage which corresponds to the position of S12.

This voltage — the MD common voltage — causes IC2 to indicate the proper diaphragm opening for the light conditions. But, if you fail to set the smallest aperture, IC2 only lights the overexposure or underexposure LED in the S mode.

What if the IC fails to receive the MD common voltage signal? You'll then find that the LED readout won't display the diaphragm setting at the S mode. Although you can't reach pin 9 of IC2, you can check the MD common voltage at the top of the camera; just measure the voltage to the connection from the minimum-aperture resistor shown in Fig. 54.

Set the mode selector to the S position, Fig. 55. Then partially depress the release button and measure the MD common voltage. Without a lens, you should measure around 1.4V. Minolta specifies

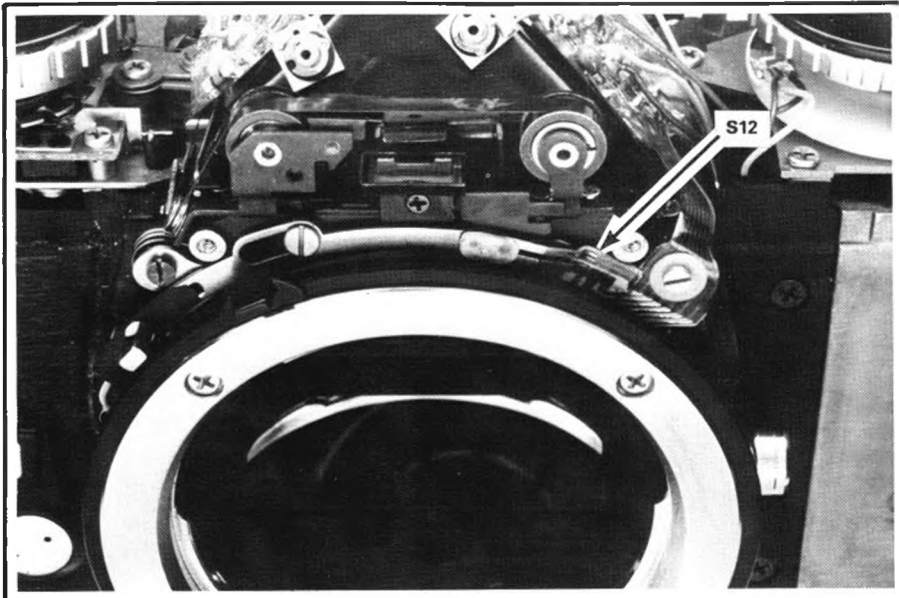

Figure 53

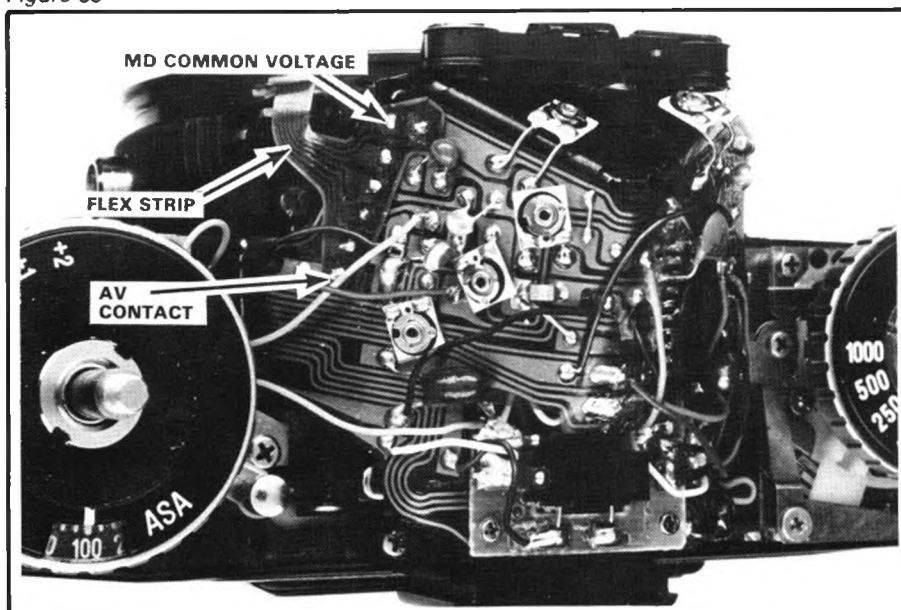

Figure 54

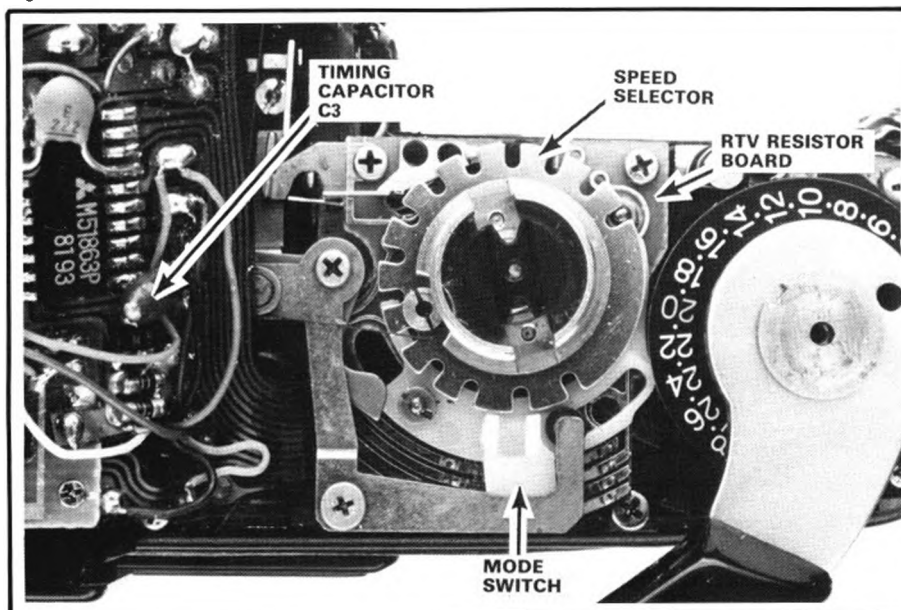

Figure 55

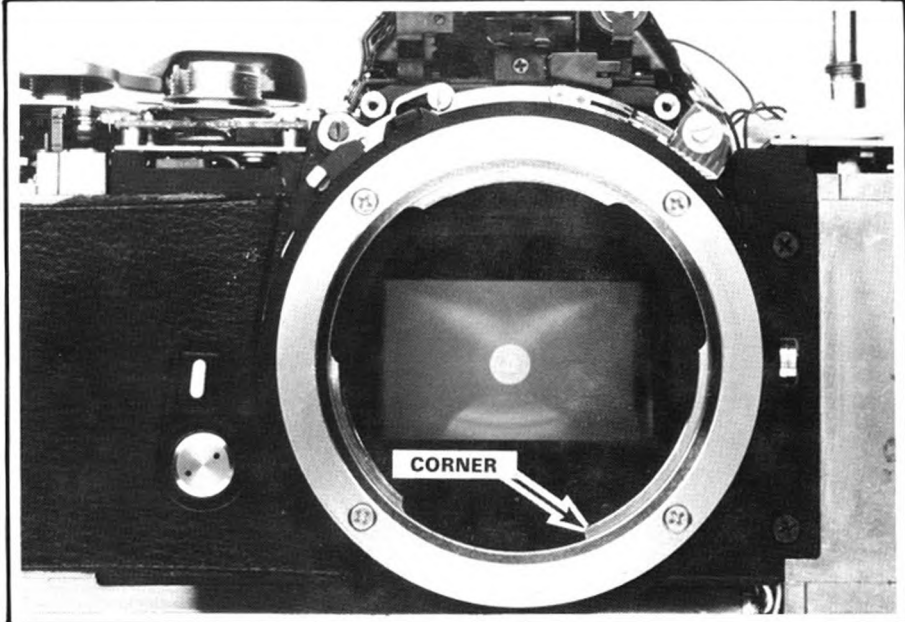

Figure 56

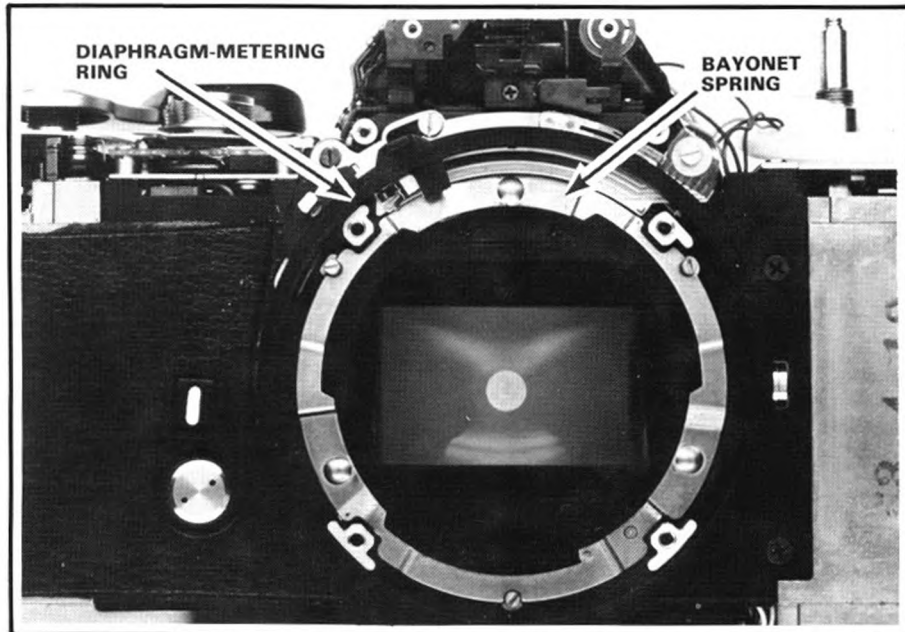

Figure 57

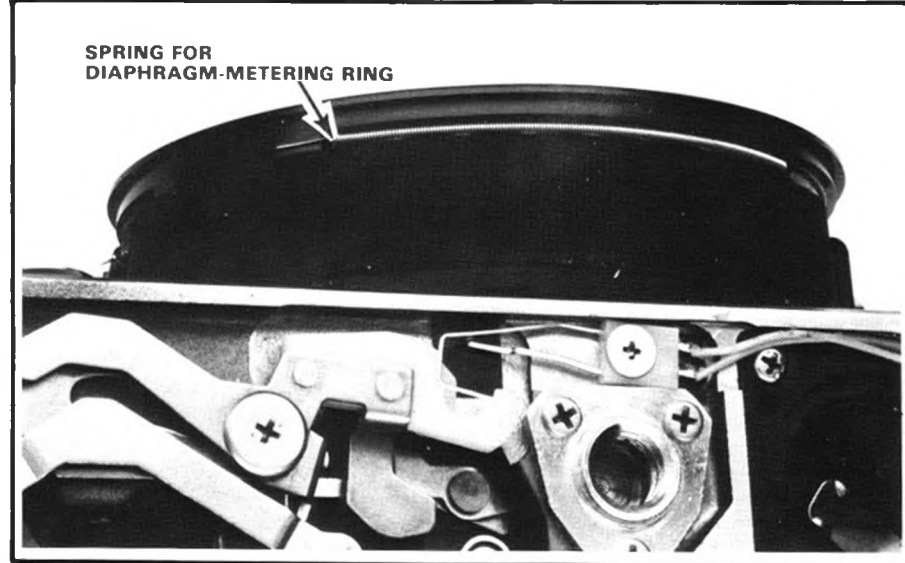

Figure 58

the voltage range of 1.1 to 2.2V without a lens.

With the MD f/16 lens set to the minimum aperture, you should measure 200 to 300 millivolts. The f/22 lens should give you a reading of 2.9 to 3V. And the f/32 lens should provide the MD common voltage of 2.1 to 2.3V.

But, if you measure 0V, you know there's a problem with the minimum-aperture resistor or with the mode selector S8. First check the contact at the right-hand side of the mode selector brush, Fig. 55. Notice that Fig. 55 shows the later model of the camera. Here, Minolta added the bridge over the mode selector to maintain better brush contact.

If cleaning the mode selector doesn't solve the problem, suspect the minimum-aperture resistor. Also, it's possible that you have a break in the strip of flex circuit, Fig. 54. The flex-circuit strip connects the minimum-aperture and diaphragm resistors to the main circuit board. In that case, you'll have to replace the complete resistor board, Fig. 53; we'll describe the procedure in a moment.

Poor contact in the diaphragm resistor also causes the overexposure LED to remain on. You can use another voltage check to test the diaphragm resistor after removing the top cover. Measure the voltage between ground and the AV contact, Fig. 54; you should measure around 2.9V with the release button partially depressed. Now rotate the diaphragm-metering ring against its spring tension as you monitor the voltage. You should see the voltage smoothly decrease to around 2.8V.

REPLACING THE MINIMUM-APERTURE RESISTOR

To clean and reform the brushes of the minimum-aperture and diaphragm resistors, you'll probably have to remove the lens-mounting ring. You'll also have to remove the lens-mounting ring to replace the resistor board. Notice the position of the lens-mounting ring in Fig. 56; the corner indicated in Fig. 56 must go toward the bottom of the camera.

Now remove the lens-mounting ring by taking out its four screws. Then lift out the bayonet spring, Fig. 57. Also disconnect the spring from the diaphragm-metering ring, Fig. 58. When you lift out the diaphragm-metering ring, the spring should stay connected to the spring clip, Fig. 59.

The long resistance path you can now see, Fig. 59, is the diaphragm resistor; the brush remains with the diaphragm-metering ring. To remove the brush assembly for the minimum-aperture resistor, disconnect its spring and remove the

two shoulder screws, Fig. 59.

That's as far as you'll have to go in disassembly to clean the brushes and the resistor board. However, replacing the resistor board requires a little more work. First unsolder the seven connections joining the resistor-board flex strip to the main flex circuit, Fig. 54. A new resistor board comes with the strip of flex circuit:

Now remove the two screws, Fig. 59, and lift out the resistor board. Notice that you can shift the position of the resistor board before tightening the screws. The shifting adjustment allows you to precisely align the minimum-aperture resistance paths, Fig. 59, with the brush.

When you install the new resistor board, be very careful to *avoid overtightening the screw with the washer*, Fig. 59. Overtightening the screw can break the connectors within the flex-circuit strip. You'll then have the same problem — no MD common voltage.

Then, after you reassemble the diaphragm-metering ring and the lens-mounting ring, adjust the position of the resistor board. With no lens, the brush

should center on the first resistance path, Fig. 59. You might also check the adjustment with the f/16 MD lens installed. At the f/16 setting, the brush should center on the second resistance path.

CHECKING SWITCH S7

As mentioned earlier, the LED display turns off when you release the shutter. When M1 repels its armature, switch S7 opens, Fig. 52. Opening S7 disconnects IC2 from ground. So, if S7 fails to make good contact, none of the LEDs will turn on.

With the front-plate/mirror-cage assembly removed, you have a good view of S7, Fig. 60. Fig. 60 shows the mirror cage in the charged position. The M1 armature now sits in contact with the core of the combination magnet. Notice that the pin on the armature comes against the blade of S7. The S7 blade then connects to ground through the armature.

S7 remains connected to ground until the M1 armature moves away from the core. In Fig. 61, we're holding open the shutter on bulb. Also, we've pushed the

M1 armature away from the core. As you can see, the pin on the armature has moved away from the S7 blade.

After the exposure, the cam ridge on the mirror-tensioning lever, Fig. 62, once again drives the M1 armature against the core of the combination magnet. Cocking the mirror cage for the next exposure moves the cam ridge away from the M1 armature, Fig. 60. But, because of the permanent magnet in the core of M1, the armature remains in place.

You may have to remove the front-plate/mirror-cage assembly to repair S7. However, you can check S7 by just removing the bottom plate. The white wire connected to the S7 blade, Fig. 62, goes to the lower circuit board.

Suppose, then, that none of the LEDs will turn on. Try checking the continuity between the white wire and ground. You should measure direct continuity until you release the shutter on an electronically controlled speed. If you don't measure direct continuity, S7 isn't making good contact with the M1 armature.

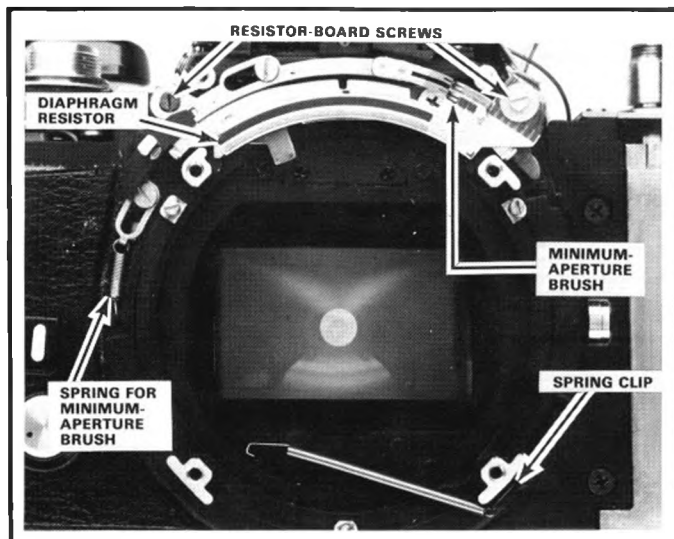

Figure 59

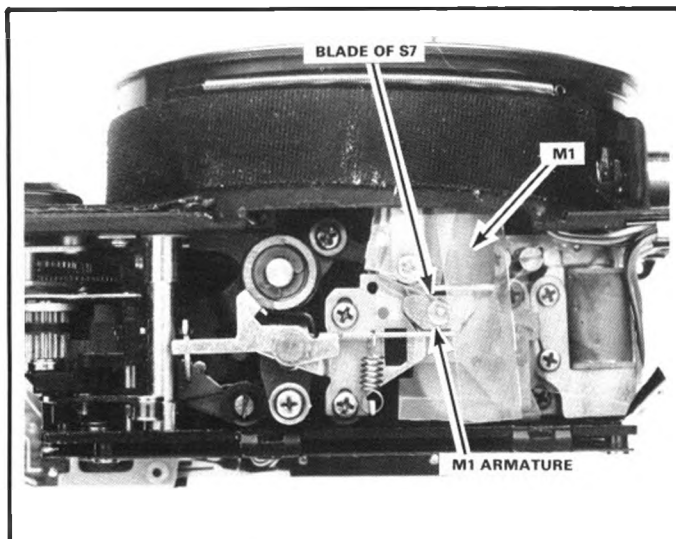

Figure 60 Mirror charged

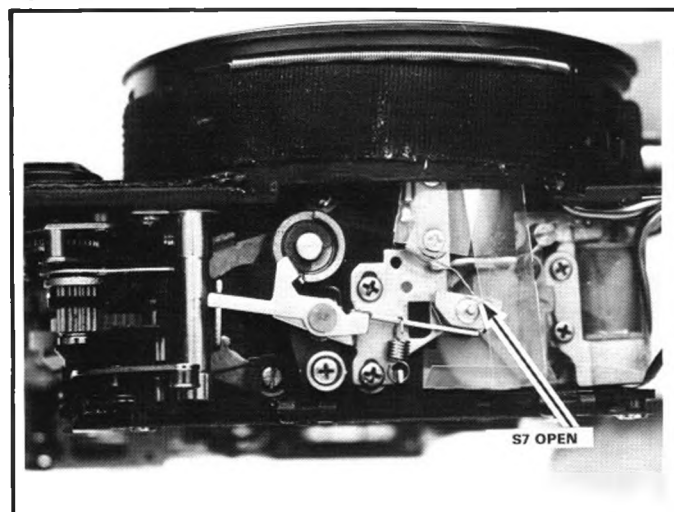

Figure 61

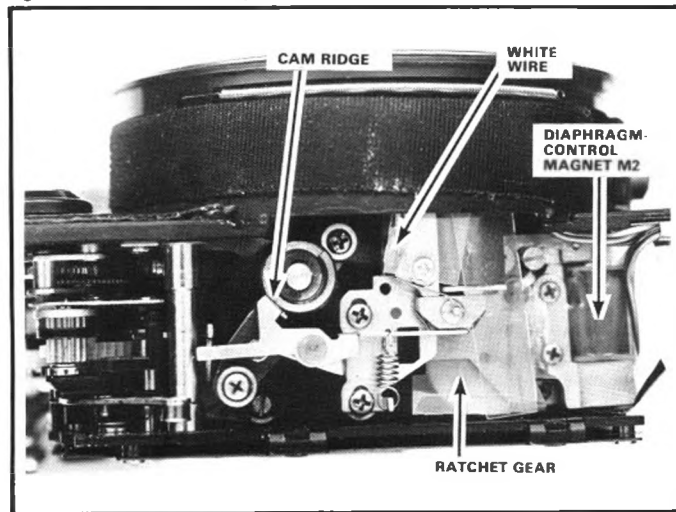

Figure 62 Mirror released

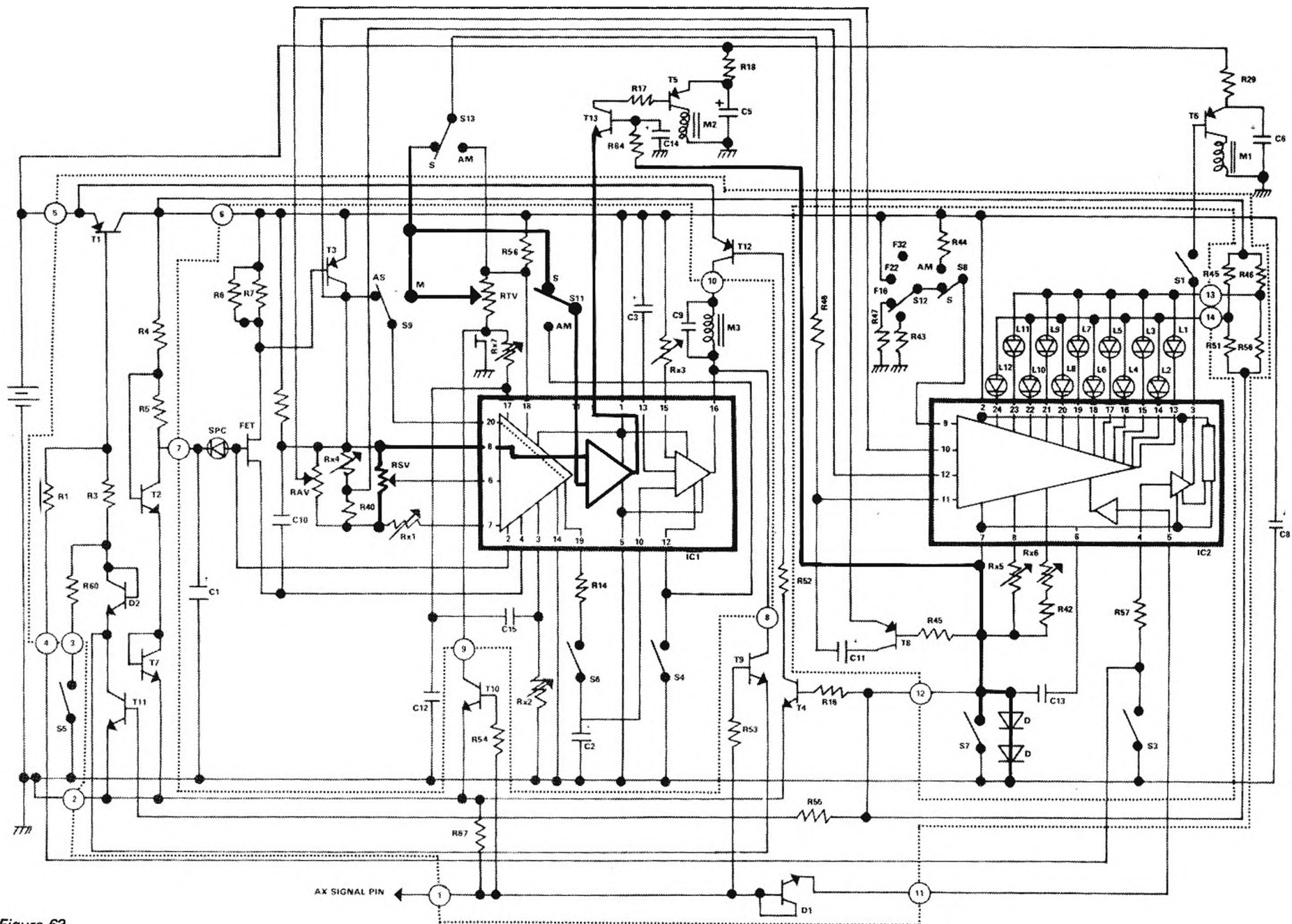

Figure 63

DIAPHRAGM-CONTROL CIRCUIT

In the S mode, IC2 tells you what diaphragm opening you should get. But IC1 provides the actual calculation and control, Fig. 63. The comparator inside IC1 compares the shutter-speed information with the light-level and film-speed information to make its decision — the decision when to turn on T13, Fig. 63.

Remember that S7 remains closed until the M1 armature moves away from the core. With S7 closed, the base of T13 connects to ground through R64. However, when S7 opens, the base of T13 sees a positive voltage. The voltage applied to the base of T13 is the sum of the voltage drops across each of the diodes shown next to S7 in Fig. 63 — around 1.2V. In the camera, you can see the two diodes next to H-IC, Fig. 48.

T13 now has the positive voltage it needs at its base. However, the transistor still can't conduct. That's because the voltage at pin 9 of IC1 — the output of the comparator — remains high. In effect, opening S7 just prepares T13 to turn on. T13 then remains at the ready, waiting only for the voltage at its emitter to switch low.

The comparator inside IC1, Fig. 63, controls the emitter voltage of T13. At pin 11, the comparator sees the shutter-speed information from RTV. The comparator sees the film-speed and brightness information at pin 8. As long as the voltage at pin 11 remains less positive than the voltage at pin 8, the output of the comparator stays high.

However, as the diaphragm stops down, the voltage at pin 8 decreases. Why? Because the SPC sees less light. When the voltage at pin 8 reaches the voltage at pin 11, the comparator switches states — its output goes low. The voltage at pin 9 of IC1, Fig. 63, then switches to 0V.

Switching the emitter of T13 to 0V provides the transistor with a forward bias of 1.2V; remember, T13 already has the 1.2V signal at its base. T13 now turns on, sending base current through T5. When T5 turns on, C5 discharges through the coil of M2 to arrest the diaphragm closure.

The shutter-speed setting, as you've seen, just changes the voltage input at one lead of the comparator. So, to check the shutter-speed resistor RTV, you can measure the pin 11 voltage in the S mode. You should see the voltage go more positive as you set faster shutter speeds. Since the voltage goes more positive, the diaphragm doesn't have to stop down as far in bringing the pin 8 voltage to the pin 11 voltage.

At the X, B, and 0 settings, the shutter-speed brush moves to the ground land

shown just below the RTV resistor in Fig. 63. Pin 11 of IC1 now connects to ground. As a result, the voltage at pin 8 never reaches the voltage at pin 11. And the diaphragm-closing lever always has its full movement.

You'll notice that the diaphragm-closing system works independently of the readout. In the first part of this article, we mentioned that the MC lens won't give you the proper indication in the LED display; it lacks the tab which couples to the minimum-aperture resistor. However, you can still use the MC lenses with the camera. Although you won't get the diaphragm readout, the lens nonetheless stops down to the proper aperture in the S mode. The diaphragm-control magnet still arrests the diaphragm closure.

With the front-plate/mirror-cage assembly removed, you can see the diaphragm-control magnet, Fig. 62. Locate the ratchet gear in Fig. 62. When C5 discharges through the coil of M2, the armature moves into engagement with the ratchet gear. Stopping the rotation of the ratchet gear also stops the movement of the diaphragm-closing lever.

In the A and M modes, the diaphragm-closing lever must again have its full movement. The diaphragm then closes to whatever f/stop you've selected. When

you select either A or M, switch S11 (part of the mode switch) connects pin 11 of IC1 to ground through the trigger switch S4. Consequently, the pin 8 voltage never reaches the pin 11 voltage.

OPERATION IN THE A MODE

In the A mode, the shutter-speed resistor RTV has nothing to say about the operation. Switch S9, Fig. 63 (another contact on the mode switch) disconnects the shutter-speed resistor from the circuit. Then, regardless of your shutter-speed setting — 1 second through 1/1000 second — you get an automatically controlled shutter speed.

The charge across the memory capacitor C2 now controls the exposure time. Fig. 64 shows the circuit inside IC1 that charges the memory capacitor and controls the current to the timing capacitor C3. As long as the memory switch S6 remains closed, the charge across the memory capacitor can continue changing.

When the diaphragm reaches the proper aperture size, the memory switch opens. Now the mirror starts to rise. Even though the SPC can no longer see the light coming through the lens, the circuit has a memorized reference voltage — the voltage stored in the memory capacitor.

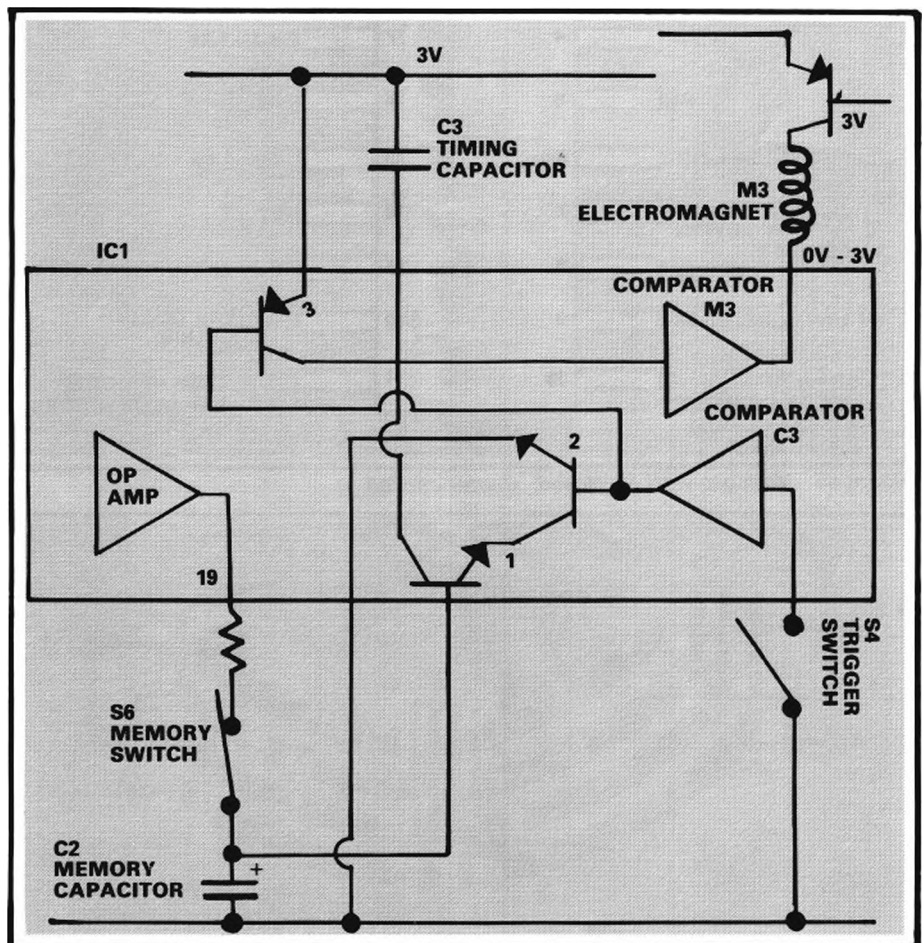

Figure 64

Notice in Fig. 64 that the memory-capacitor voltage provides the base bias for transistor #1 inside IC1. The transistor bias determines how fast the timing capacitor C3 can charge. However, the timing capacitor can't start charging until the trigger switch S4 opens. As long as S4 remains closed, it keeps the C3 comparator switched low. In turn, the comparator keeps transistor #2 turned off.

Then, as the opening blade starts to move, it opens the trigger switch. The C3 comparator now switches high and turns on transistor #2, Fig. 64. As a result, current flows from ground, through transistor #2, and through transistor #1 to charge the timing capacitor C3.

The higher the memorized reference voltage, the faster the timing capacitor will charge. A higher reference voltage provides a larger base drive to transistor #1, Fig. 64. Transistor #1 then conducts more current.

During the C3 charging cycle, current flows through the closing-blade elec-

tromagnet M3, Fig. 64. Right now, the output of the M3 comparator remains at 0V. The electromagnet then has a 3V difference in potential. Since current flows through the coil, the M3 electromagnet holds the closing blade to keep the shutter open.

Then, when the timing capacitor reaches a high enough voltage, it triggers the M3 comparator. As a result, the comparator switches states — its output goes to 3V. Now there's no difference in potential across the electromagnet. So the electromagnet releases its armature and frees the closing blade.

OPERATION IN THE M MODE

In the M mode, the shutter speed still depends on the charge across the memory capacitor. However, the shutter-speed setting (the resistance of RTV) determines the memory-capacitor voltage. At M, switch S9 moves from the "AS" position to the "M" position, Fig. 63.

Switch S9 now connects RTV to pin 20 of IC1, Fig. 63. As you set faster shutter speeds, the voltage at pin 20 goes more positive. The voltage at pin 19 also goes more positive at the faster speed settings.

As the voltage at pin 19 goes more positive, the voltage across the memory capacitor increases. The remaining operation matches that we described for automatic operation. Increasing the voltage across the memory capacitor provides a larger base drive for transistor #1, Fig. 64. The timing capacitor then charges more quickly.

You can then check the shutter-speed resistor RTV by measuring the voltage to pin 20 of IC1 in the M mode. Again, the voltage should go more positive as you set faster shutter speeds. At the X, B, and 0 settings, though, you should measure 0V at pin 20.

What if you measure 0V at the other settings? There's evidently an open in the shutter-speed resistors. Most likely, you'll simply find poor contact between the brush at the bottom of the speed selector, Fig. 55, and the RTV resistance band. You can then remove the speed selector (a procedure we'll later describe) to improve the brush contact and clean the surfaces of RTV.

Here's another possibility — the shutter works fine throughout part of the speed range yet hangs open during the rest of the speed range. For example, you may find that the shutter works properly at the speeds of 1 second through 1/60 second. But it hangs open at the speeds of 1/125 second through 1/1000 second.

The problem could indicate a break in the RTV resistance band. But you may find that the RTV resistor board has simply shifted out of position. As a result, the speed-selector brush rides off the resistance band. Try shifting the position of the RTV resistor board after loosening its three screws, Fig. 55.

PIN VOLTAGES, IC1

Once you're familiar with the schematic, you can perform much of the troubleshooting at the pins of IC1, Fig. 65. Fig. 65 shows the pin voltages for IC1 with the metering switch S5 closed. Normally, the voltage at pin 1, will be a little less than 3V; it's the battery voltage minus the drop across T1, Fig. 63.

Earlier, we indicated that you can check the RTV resistor at pin 20, Fig. 65. In the M mode, the voltage should go from around 1.1V at the 1-second setting to around 1.36V at the 1/1000-second setting. You should measure 0V at the 0, X, and B settings. If you measure 0V at any of the other settings, suspect poor contact in the shutter-speed resistor.

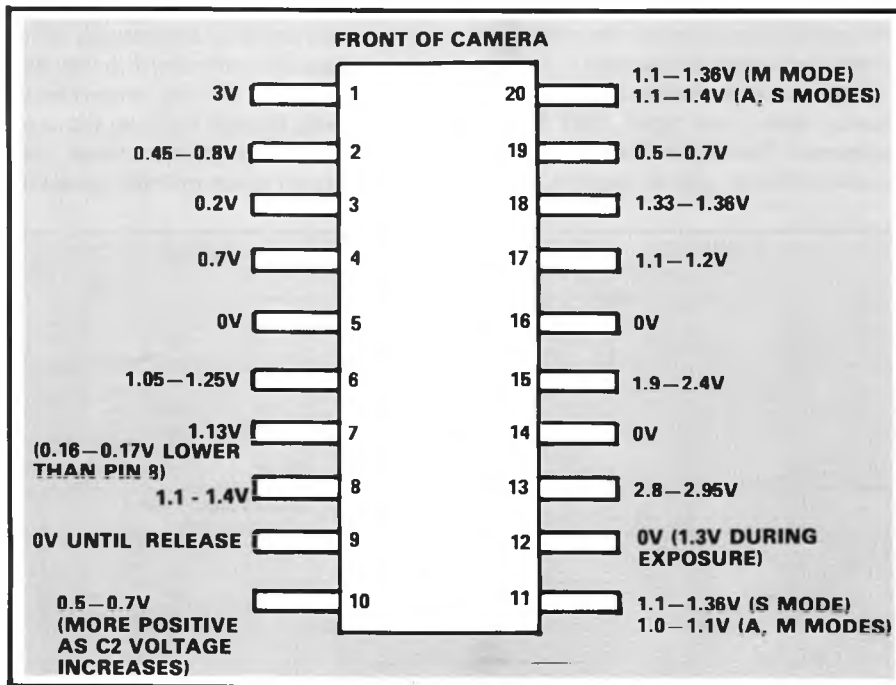

Figure 65 Voltages with S5 closed, shutter cocked

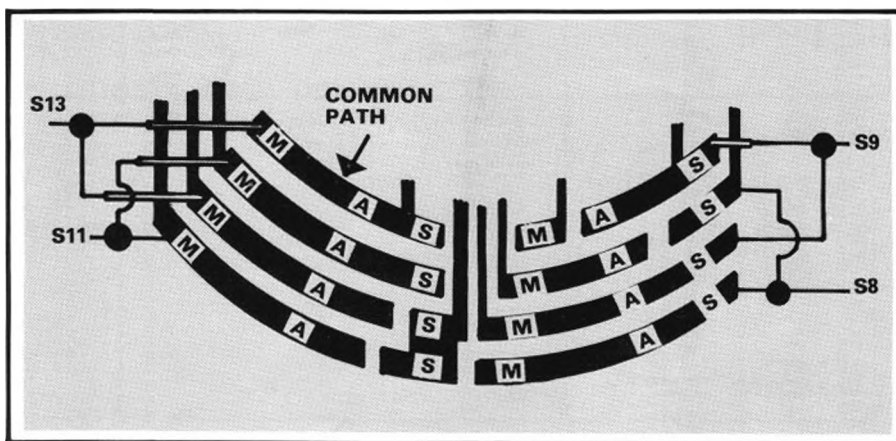

Figure 66

Pin 19, Fig. 65, provides the charging voltage for the memory capacitor. The voltage at pin 19 should go more positive as you set faster shutter speeds on manual or as you increase the light level on automatic. The same voltage appears at pin 10. Pin 10 couples the memorized reference voltage from the memory capacitor to the current-control circuit that charges the timing capacitor.

At pin 9, you should see a 0V signal until you release the shutter. The voltage then swings positive to negative (0V) to turn on T13.

You can check switching actions at the other pins. For example, pin 12 connects to the trigger switch. With the shutter cocked, you should measure 0V at pin 12; the closed trigger switch then connects pin 12 to ground. However, you should measure around 1.3V during the exposure when the trigger switch opens. What if you don't? If the voltage stays at 0V, suspect a problem with the trigger switch.

Another switch — S11 of the mode switch — connects to pin 11. If the shutter delivers only the mechanical exposure in all modes, you might check the pin 11 voltage. You should see the voltage change as you move the mode switch from the S position to the A position. If not, suspect poor contact in S11.

As another example, S9 of the mode switch connects to pin 20. Here, you should see a voltage change as you go from the M mode to the A mode. Poor contact in S9 could cause the shutter to hang open in all modes. Fig. 66 points out the mode-switch paths that correspond to S8, S9, S11, and S13.

MODIFICATION TO THE TIMING CIRCUIT

You may recall the symptom of a shorted memory capacitor C2 — the shutter hangs open on all modes. With no voltage across the memory capacitor,

transistor #1, Fig. 64, has no base drive. Consequently, it can't charge the timing capacitor. The same symptom may result from poor contact in the memory switch.

Similarly, under very low light conditions, there's a low voltage across the memory capacitor. If you operate the camera at one of the automatic settings in complete darkness, the shutter hangs open until the batteries die. You can, of course, remove the batteries to close the shutter. But Minolta discovered that owners were going through batteries by letting their shutters hang open.

At the current price of silver-oxide batteries, Minolta felt the problem deserved a modification — a modification that allows the timing capacitor C3 to eventually charge. Minolta suggests adding a large-value resistor — 50 megohms — between pin 14 of IC1 (ground) and the negative lead of C3, Fig. 55.

The large resistor has no effect on the normal operation. However, it allows the timing capacitor to eventually charge and close the shutter. You may have some trouble locating a 50M resistor that's small enough in size. Fortunately, Minolta does supply the resistor through their parts department; it's part number 9431-1078-31.

REPAIRING AND ADJUSTING THE COMBINATION MAGNETS

We've already described the troubleshooting steps to detect an open coil in either M1 or M2, Fig. 63. Remember, an open M1 coil prevents the mirror from releasing. If M2 has an open coil, the diaphragm always stops down fully in the S mode.

However, you may also encounter mechanical problems with the combination magnets. Dirt causes one such problem. For example, dirt between the M1 armature and the magnet core prevents the magnetic attraction. As a result, the mir-

ror releases as soon as you complete the cocking stroke.

Dirt can cause a similar problem with the M2 magnet. If M2 fails to hold its armature, the diaphragm can't stop down. The armature arrests the ratchet gear as soon as the diaphragm starts to close. Minolta has improved both the M1 magnet and the M2 magnet to minimize the dirt problem. In the newer designs, the armature moves a rod within a hole. The hole serves to seal both the armature and the core from dirt.

Incorrect adjustments cause similar problems. But you normally don't have to adjust the magnets — not unless you've replaced either M1 or M2. If you replace a magnet, you'll have to adjust its position.

Check the adjustment on M1 with the mirror cage in the charged position, Fig. 67. The end of the M1 armature should now overlap the top of the charge cam, Fig. 67, by 0.1 to 0.15mm. Also, there should be a space gap of 0.3 to 0.8mm between the M1 armature and the mirror-release lever, Fig. 67.

To adjust M1, just loosen its two screws, Fig. 67. Then shift the position of the magnet. Also check to make sure that the armature comes against the magnet core, Fig. 67. If the M1 armature fails to engage the core — yet the M1 adjustment appears to be correct — you can reform the section of the armature that carries the keeper, Fig. 67.

The diaphragm-control magnet M2 has a similar sliding adjustment. Set the speed selector to bulb. Then cock and release the mirror cage; hold down the release slide to keep the mirror in the raised position.

Now push the M2 armature away from the core, Fig. 68. Check the space gap between the core and keeper at the end of the armature; the space gap should be between 0.4 and 0.6mm. To adjust the space gap, loosen the two screws and shift the position of M2.

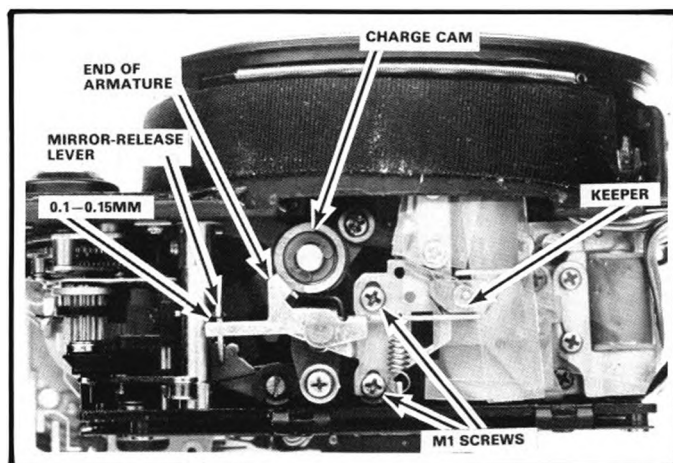

Figure 67

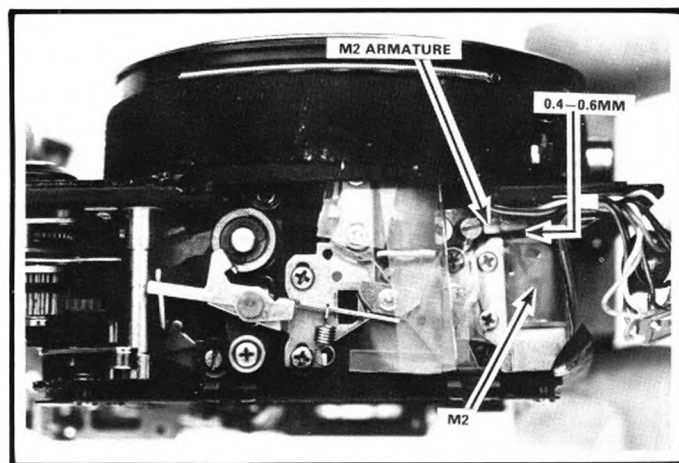

Figure 68

EXPOSURE AND READOUT ADJUSTMENTS

For many of the repairs in the XD-11, you won't have to disassemble the camera any further than we've described. The modular construction then makes the camera fast to service. Let's say you've replaced the front-plate/mirror-cage assembly. You're then ready to make the adjustments.

Remember that you should avoid disturbing the two variable resistors for the LED readout — Rx5 and Rx6, Fig. 48. Setting up the other adjustments should bring in the accuracy of the LED display. But, if the LED readout remains off by more than 1 EV, you can pull out the front-plate/mirror-cage assembly far enough to reach the variable resistors. It's also possible — though not recommended — to reach the adjustments through the cutout on the side of the lens mount. Using a curved tool to turn the "blind" variable resistors could do more harm than good.

Start by checking the MD common volt-

age, Fig. 54. We described the test during troubleshooting. As you'll recall, you should measure from 1.1 to 2.2V without a lens installed. There's no adjustment on the MD common voltage other than shifting the minimum-aperture resistor. However, if you aren't getting the MD common voltage, you won't be able to adjust the LED readout in the S mode.

CALIBRATING THE MANUAL SHUTTER SPEEDS

The two variable resistors at the front of the flex circuit, Fig. 69, provide your adjustments for the manual speeds. Rx7 adjusts the constant-current source. With the proper amount of current to the timing circuit, the shutter speeds should be linear.

Set the mode switch to M. Then connect a digital voltmeter between Rx7 and fixed resistor R56 as shown in Fig. 69. Depress the release button part way to measure the voltage.

You should get a reading of 180mv

(0.180V) \pm 2mv. If not, make the adjustment using Rx7. Turning the wiper of Rx7 in a clockwise direction causes the voltage to increase.

Now use variable resistor Rx3, Fig. 69, to adjust the manual 1/30-second shutter speed. Minolta recommends setting the exposure time to 31.2ms. The other manually calibrated shutter speeds should then time properly.

But you'll sometimes find that the fastest speed — 1/1000 second — remains too slow. In that case, check first the blade-travel times. The blades should cross a 20mm distance in 6ms. If not, you'll have to remove the shutter and adjust the blade tensions.

There's one more adjustment that affects 1/1000 second — the eccentric for the shutter's trigger switch. Changing the moment at which the trigger switch opens has a significant effect on 1/1000 second. But the adjustment has very little effect on the other shutter speeds.

It's possible — albeit delicate — to adjust the trigger switch without removing the shutter. You can reach the eccentric through the clearance cutout shown in Fig. 70. However, you're again faced with a "blind" adjustment.

Later, after we remove the shutter, we'll go through another technique you can use to adjust the trigger switch — one that involves adjusting the eccentric for 1/1000 second before replacing the shutter. Still, you won't want to remove the shutter for every XD-11 repair. You may then have to use the clearance cutout, Fig. 70, to adjust 1/1000 second.

ADJUSTING THE ASA INCLINATION

Variable resistor Rx1, Fig. 71, sets the ASA inclination — the actual signal change for a change in the film-speed setting. Properly adjusting the ASA inclination should eliminate the need to disturb

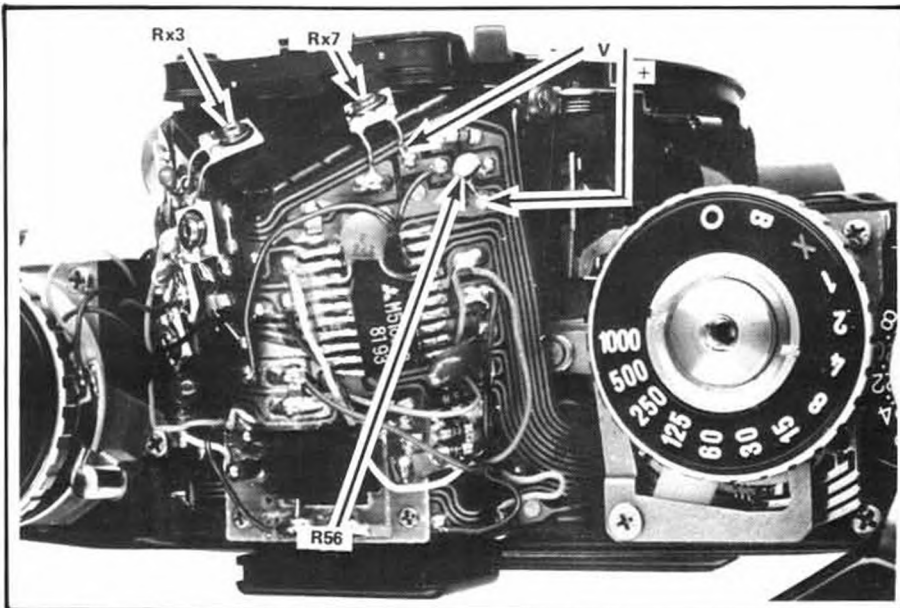

Figure 69

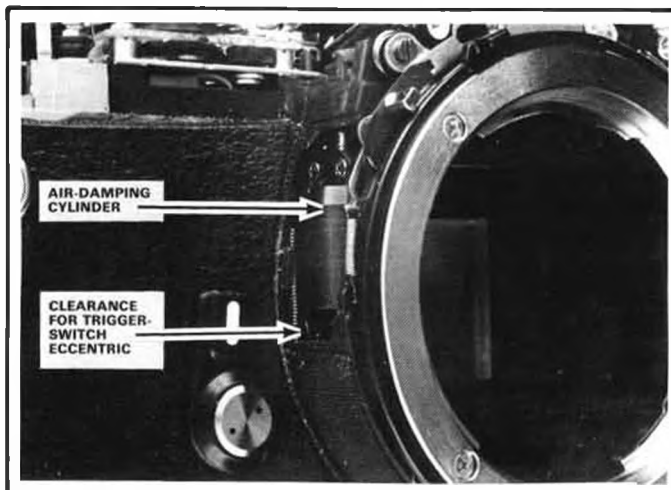

Figure 70

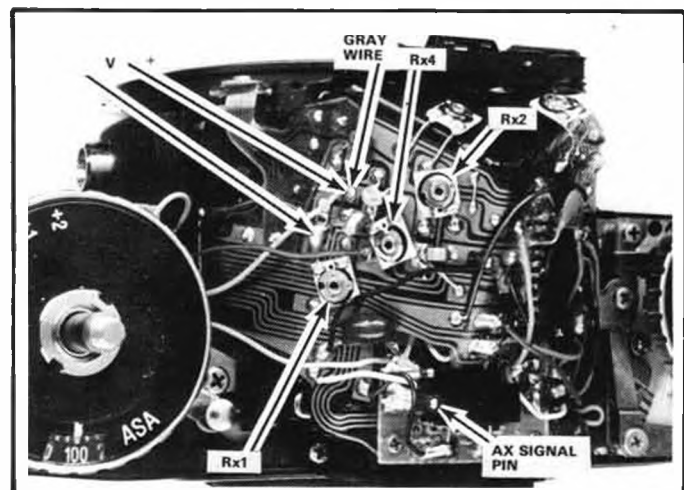

Figure 71

the variable resistors on the side of the mirror cage.

To check the ASA inclination, measure the voltage between the lead of Rx1 and the flex-circuit land that has the gray SV wire, Fig. 71. You should measure 144mv \pm 2mv. Adjust the voltage by turning the wiper of Rx1 — clockwise to decrease the voltage, counterclockwise to increase the voltage.

AUTO EXPOSURE ADJUSTMENT

Adjust Rx2, Fig. 71, to correct the auto exposure in the A mode. Minolta recommends testing the automatic shutter speeds at f/5.6, ASA 100. Check the exposure at EV 15, EV 11, and EV 9. Be sure to shield the top of the camera from ambient light, especially at the EV 9 light level.

CHECKING THE AUTO DIAPHRAGM OPENINGS

There's no adjustment for the auto diaphragm openings. However, you should still check the accuracy. Checking the auto diaphragm openings at the S mode verifies proper operation as well as the accuracy of the previous adjustments.

Set the mode selector to S. Then check the diaphragm opening at ASA 100 and EV 11. Remember, the diaphragm-setting ring must be at the smallest aperture setting. The following chart shows the actual aperture and the exposure time you should be getting at different shutter-speed settings:

SHUTTER SETTING	DIAPHRAGM OPENING	EXPOSURE TIME
1/125 second	f/4	3.91 - 15.6ms
1/60 second	f/5.6	7.81 - 31.3ms
1/30 second	f/8	15.6 - 62.5ms
1/15 second	f/11	31.3 - 125ms

If you're using an instrument that measures EV error, the exposure should be within \pm 0.8V at each shutter-speed setting. An out-of-tolerance reading normally indicates an error in the previous adjustments.

CHECKING THE LED READOUT

Now check the accuracy of the LED readout. Check first to make sure that the LEDs light properly all along the scale. If the LEDs at either end of the scale don't show up — or if the LEDs don't appear uniformly bright or centered throughout the display — you may have to shift the circuit board at the side of the mirror cage, Fig. 48.

The LED display mounts to the circuit board at the other side of the flex circuit, Fig. 48. After loosening the two ground screws, you can shift the position of the circuit board to align the LEDs with the mirror-cage prisms. Make sure that each

LED in the display centers within its hole in the viewfinder mask.

You're then ready to verify the accuracy of the readout. First check the accuracy in the A mode, ASA 100, and EV 11. At f/2.8, the "250" LED should turn on. At f/8, the "30" LED should turn on. And at f/16, the "8" LED should turn on.

Next check the accuracy in the S mode at f/16, EV 11. At 1/15 second, the f/11 LED should turn on. The f/5.6 LED should turn on at 1/60 second. At 1/500 second, the f/2 LED should turn on.

If the LED readout is not within 1 EV, recheck your previous adjustments. Use variable resistors Rx5 and Rx6, Fig. 48, only as a last resort. If necessary, you can then use Rx5 to adjust the readout in the S mode. Use Rx6 to adjust the readout in the A mode.

ADJUSTING THE UNDERRANGE LED INDICATION

The final "normal" adjustment sets the turn-on point of the underrange LED. But the adjustment takes some time — you have to compare two voltage measurements. First, set the mode switch to S, the shutter speed to 1/250 second, and the diaphragm to f/16.

With the film-speed dial set to ASA 100, expose the lens to a light level of EV 9. Now measure the voltage between the common S11 path, Fig. 66, and ground. Record your voltage reading.

Next, without changing anything, mea-

sure the voltage between pin 8 of IC1 and ground. You can measure the pin 8 voltage at the gray-wire land pointed out in Fig. 71. Compare this voltage reading with your measurement at the S11 land.

Finally, turn the film-speed dial until the voltage at the gray-wire land is 12 to 13mv lower than the voltage at S11. For example, suppose that you measured 1.313V in the first step. You must then set the voltage at the gray-wire land to 1.3 - 1.1301V. Move the film-speed brush along the resistance band until you get the proper voltage at the gray-wire connection.

Now look through the finder — the

underexposure LED should just begin lighting. Adjust Rx4, Fig. 71, so that the underexposure LED just starts to glow when the f/1.4 LED turns on.

CHECKING THE DEDICATED-FLASH OPERATION

Before closing up the camera, you should check to make sure the circuit will program the flash speed and indication with a dedicated flash. The AX signal pin, Fig. 71, receives the signal from the flash unit. With the flash unit fully charged, the signal at pin 1 of H-IC, Fig. 63, turns on transistor T10.

Turning on T10 connects pin 11 of IC1 to ground. Consequently, the diaphragm always closes to whatever f/stop you've selected. Also, transistor T9 turns on, connecting one lead of the electromagnet to ground. The shutter then stays open for a length of time determined by the flash unit. As soon as the flash unit turns off T9, the shutter closes.

So, if you apply a positive signal to the AX signal pin, you should be able to hold open the shutter. The positive voltage keeps transistor T9 turned on. Since turning on T9 connects one lead of M3 to ground, current continues to flow through the electromagnet.

Also, the positive signal should turn on the overrange LED. In Fig. 63, you can trace the signal from pin 1 of H-IC to IC2. The signal at pin 5 of IC2 turns on the overrange LED.

Connect a DC power supply between ground (negative) and the AX signal pin. Set the mode switch to M, and set the speed selector to 1/1000 second. Before turning on the power supply, check the LED indication by depressing the release button; you should get the available-light indication.

Now set the power supply to 1.3V. When you push the release button part way, the overrange LED should turn on. Next set the power supply to 1.6V and release the shutter. The shutter should stay open until you turn off the power supply.



minolta XD 11

CLEANING THE BLADES OF THE SEIKO SHUTTER

Several cameras now use the Seiko modular focal-plane shutters. Not all camera manufacturers, however, provide individual replacement parts. Many will only supply the shutter as a complete module.

But, thanks to Minolta, you have a choice — you can either replace the module as a unit or you can repair the shutter. Minolta does supply the parts individually, and most of the XD-11 shutter parts will interchange with those used in other Seiko shutters.

Three screws hold the shutter module to the mirror cage — two at the top of the

blade assembly, Fig. 72, and one at the front of the front plate (under the leatherette near the self-timer lever). You don't have to remove the eyepiece blind to reach the shutter-retaining screws as we did in Fig. 72; just push the eyepiece blind to its raised position.

However, the most common shutter repair in the XD-11 doesn't require separating the shutter from the mirror cage. For most of the shutter repairs, you need only clean the blades. Oil causes the blades to stick together.

Sticking blades often chop off part of the picture. You can spot the problem by watching the blades from the back of the aperture as you release the shutter. If

there's oil on the blades, you'll note the sluggish movement. In other cases, you may find that the shutter occasionally jams — the closing blade doesn't quite complete its release movement. Then, by pushing down the closing blade from the back, you may be able to get the shutter to operate for several cycles before jamming again. Again the problem results from oil on the blades.

Seiko later modified the blades to minimize the sticking problem. The new-style blades have dimples which prevent perfectly flat blade-to-blade contact.

To clean the blades, first remove the four screws which hold the rear cover plate, Fig. 72. As you lift off the rear cover plate, watch for loose parts. The closing-blade set has six loose sections; the opening-blade set has four loose sections. You'll also find loose spacers and washers.

Earlier shutters have loose washers over the pivot posts, Fig. 73. Some versions don't have the washers; rather, they have loose collars over the rear-cover support posts. Lift out the loose washers or collars. Then remove the six individual sections of the closing-blade set. It helps to keep the blade sections in their proper sequence for reassembly reference, Fig. 74.

Next lift out the aperture mask, Fig. 75, and the four individual sections of the opening-blade set, Fig. 76. In some versions of the shutter, you'll find another pair of washers over the pivot posts, Fig. 77.

Also note the loose shims and the loose rubberlike dampers, Fig. 77. The dampers serve to cushion the opening blade. Some versions of the shutter have a white

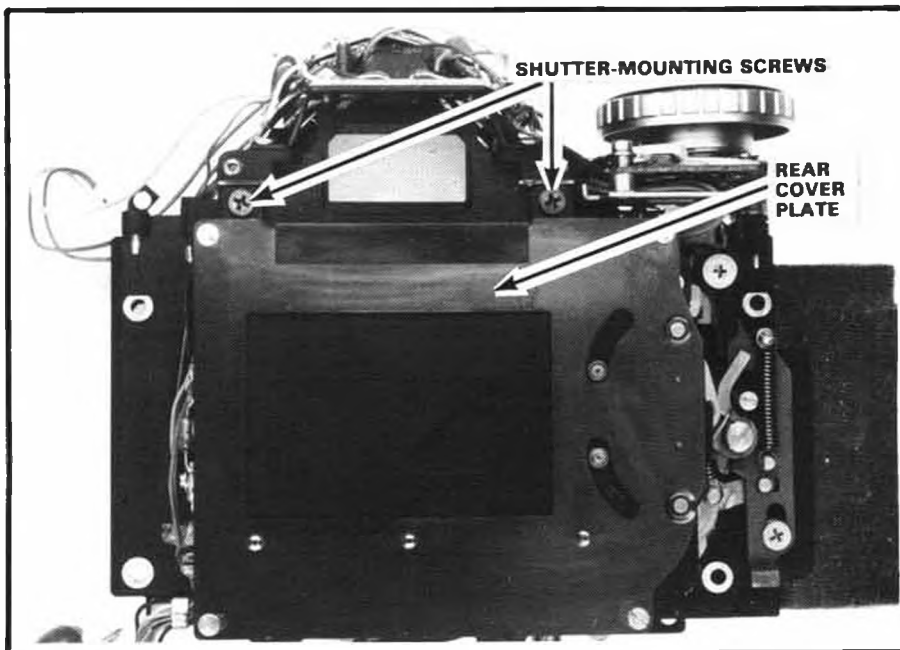

Figure 72

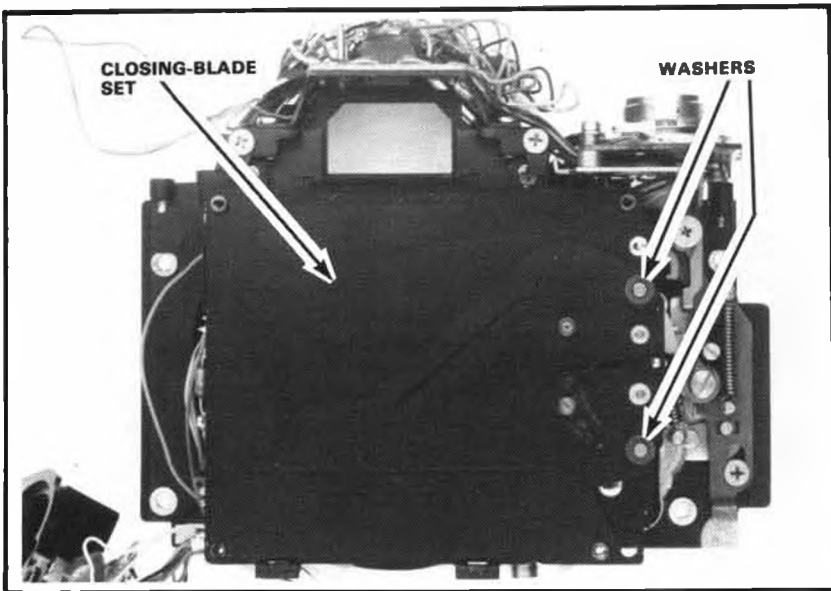

Figure 73

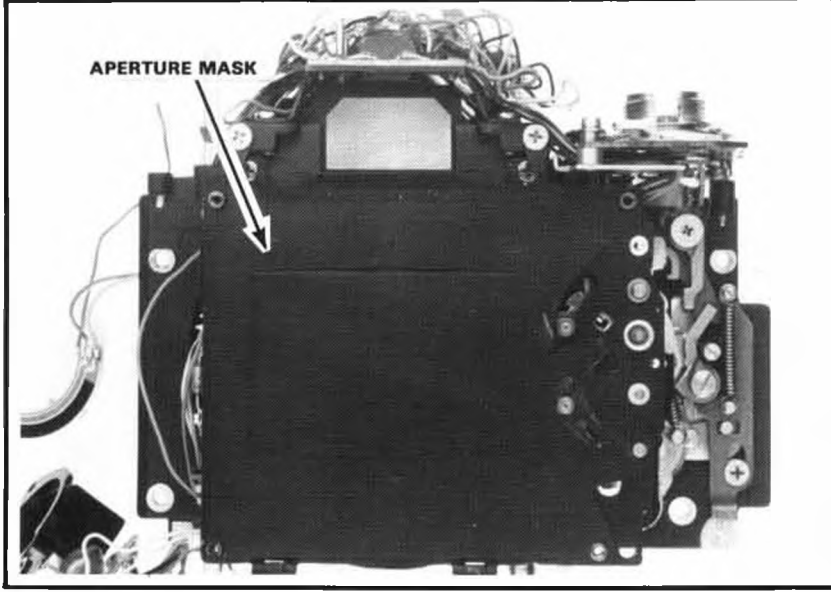

Figure 75

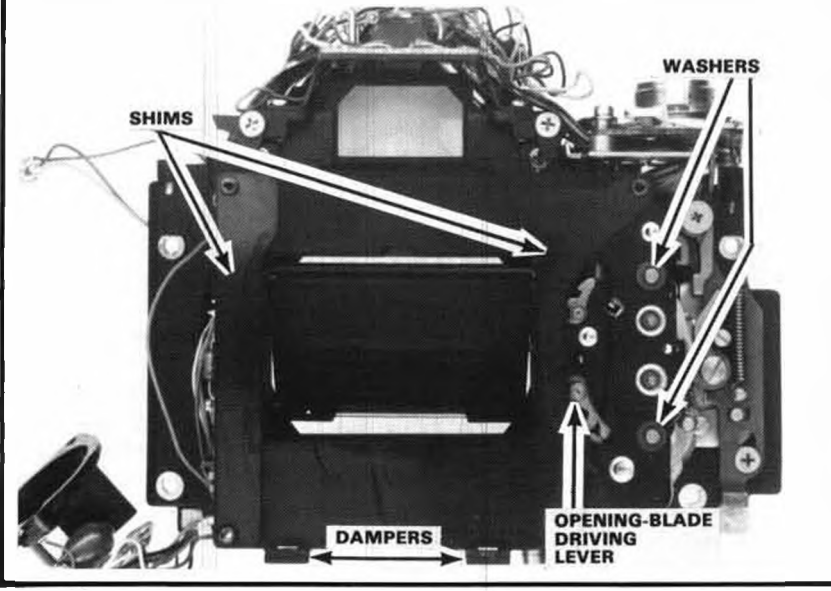

Figure 77

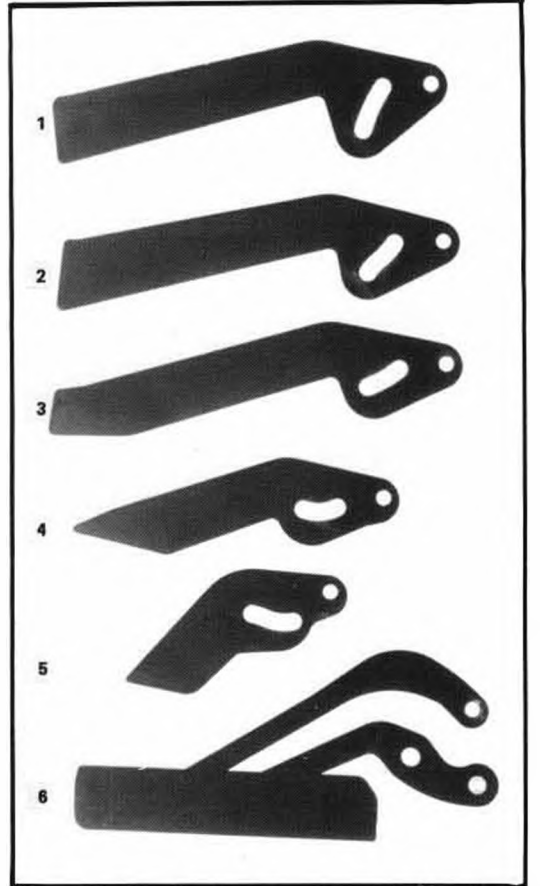

Figure 74 Closing-blade set (Part #2005-0712-01)

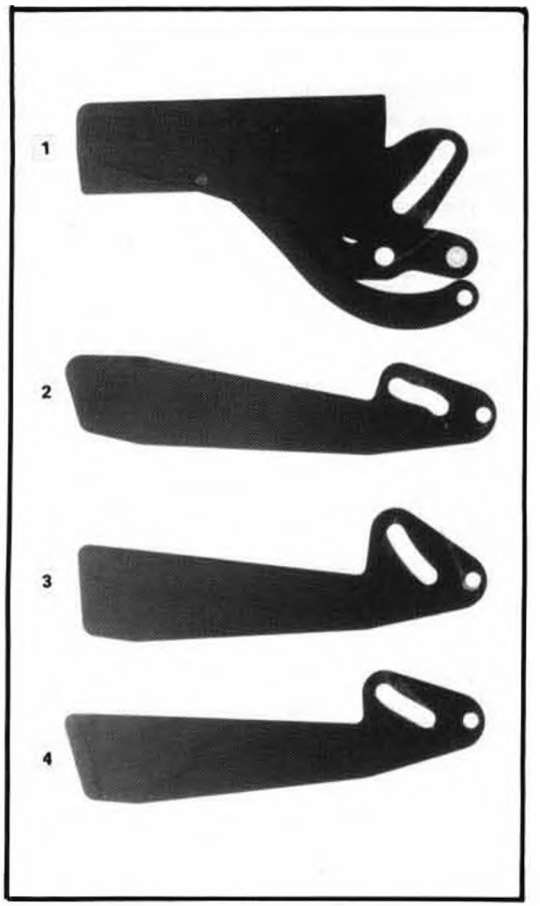

Figure 76 Opening-blade set (Part #2005-0713-01)

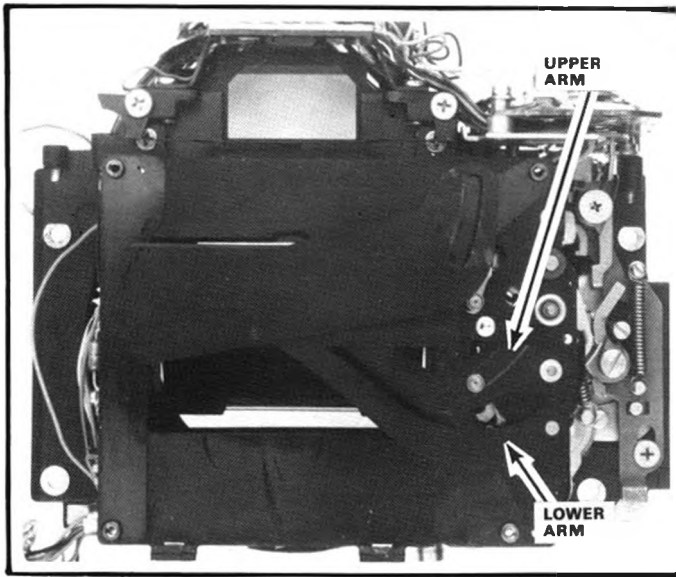

Figure 78

damper, similar in appearance to the opening-blade dampers, which fits into a slot to the right of the blades, Fig. 77.

On reassembly, first seat the shims and the dampers as shown in Fig. 77. Next place the washers over the pivot posts.

The multiple-sectioned blade of the opening-blade set, Fig. 76, may be the only "tricky" blade to replace. First position the two blade arms as shown in Fig. 78. Notice that the brass bushing on the upper arm fits over the small pin, and the hole fits over the post on the opening-blade driving lever (the lever that actually drives the blade set up and down). To position the lower arm, fit its hole over the pivot post, Fig. 78.

Now swing the large section of the blade into place. Seat the slot in the large section over the post on the opening-blade driving lever, Fig. 79. As you replace each of the remaining sections, fit the blade slot over the opening-blade driving lever and fit the blade hole over the pivot post. Once assembled, the opening-blade set should cover the focal-plane aperture.

Next replace the aperture mask and the six individual sections of the closing-blade set. The slot in each blade fits over the post on the closing-blade driving lever, Fig. 79. The hole in each blade fits over the pivot post.

In the closing-blade set, the multiple-sectioned blade goes last. Fit the brass bushing over the small pin, and seat the hole in the same arm over the post on the closing-blade driving lever. Fit the hole in the other arm over the pivot post, Fig. 73

REMOVING THE SHUTTER

To remove the shutter, take out the three shutter-retaining screws. Then lift the shutter far enough from the mirror

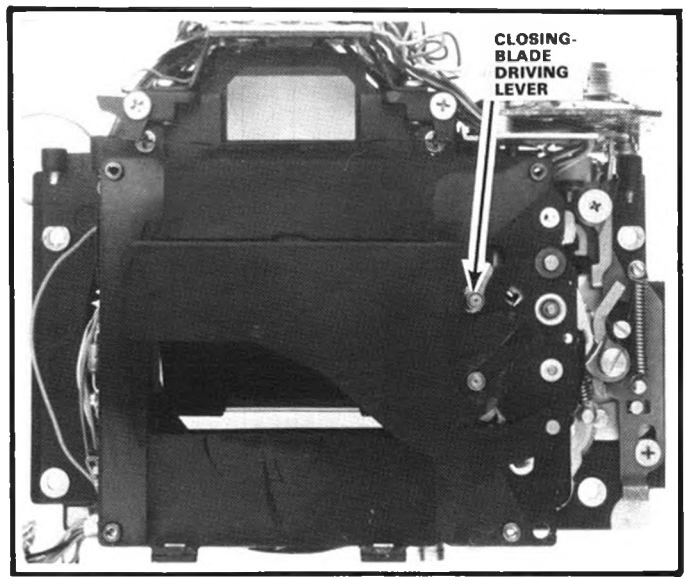

Figure 79 First section of opening blade in position

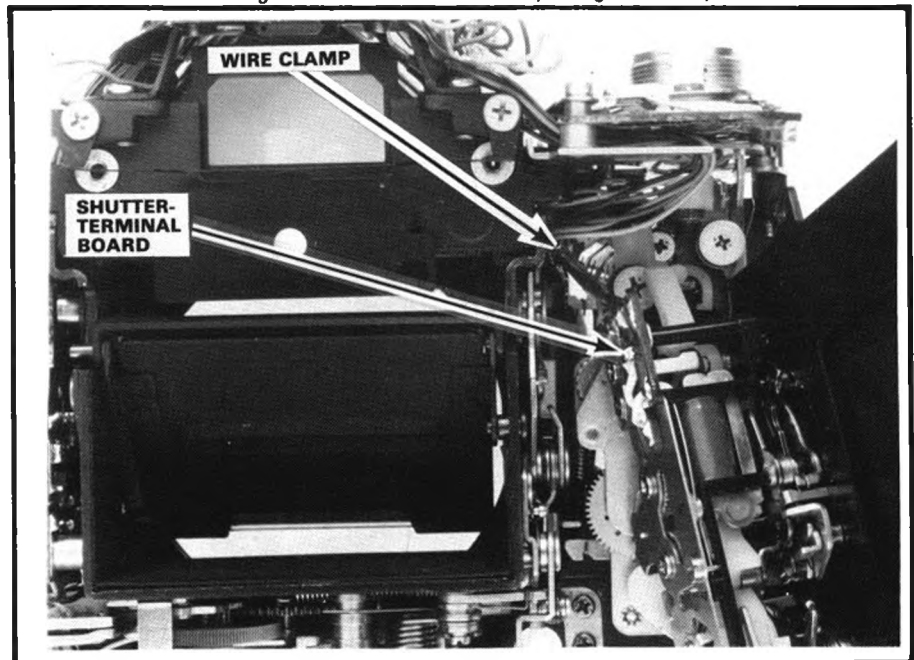

Figure 80

cage to reach the wires which connect to the shutter-terminal board.

Notice that the wires pass behind a clamp at the side of the focusing-screen mount, Fig. 80. Bend the clamp to free the wires. Then unsolder the four wires from the shutter-terminal board — red and brown to the electromagnet, gray to the X-sync contact, and the black to the trigger switch, Fig. 81.

With the shutter removed, you have a better view of the trigger-switch eccentric, Fig. 82. The eccentric, accessible through a cutout in the front plate, provides your 1/1000-second adjustment. However, you may prefer to set the trigger-switch adjustment before you replace the shutter.

Why? That way, you're sure the shutter is right before you start adjusting the shutter speeds. Also, some of the

cameras which use the Seiko shutters don't provide clearance cutouts over the trigger-switch eccentric. As a result, you can't reach the trigger-switch eccentric with the camera assembled.

Adjusting the trigger-switch eccentric with the shutter removed requires a special test circuit. With the test circuit connected to the shutter's electromagnet and trigger switch, the shutter should deliver 1/1000 second. The test circuit simply simulates the camera's timing circuit at the 1/1000-second setting.

So, with the test circuit connected, you can adjust the trigger-switch eccentric for an accurate 1/1000 second. The test box shown in Fig. 83 has a two-position switch to allow the selection of a second shutter speed. A slower shutter-speed capability can be handy as an operational check. Remember, with no current

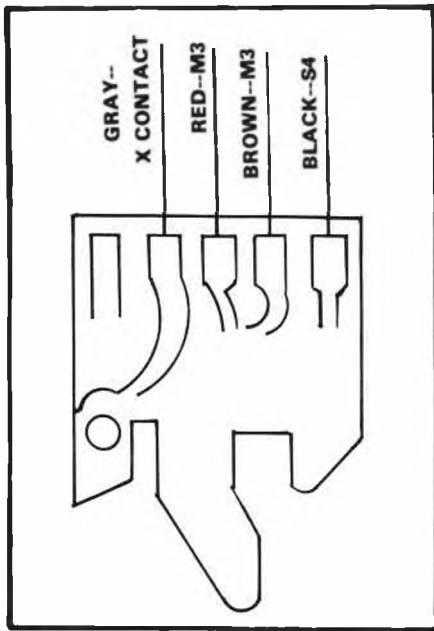

Figure 81 Shutter-terminal board



Figure 83

through the electromagnet, the Seiko delivers a mechanical speed that's very close to 1/1000 second. Consequently, you may find that you're trying to adjust the trigger switch when you're really getting the mechanical speed. By first checking the operation at a slower speed, you can at least be certain that you've properly connected the test circuit.

For the XD-11 alone, the test circuit may not be worth the trouble. However, you can use the test circuit for any of the

modular, electronic focal-plane shutters. And, since some cameras don't provide a clearance cutout over the eccentric, you may find that the test circuit comes in handy. A little later, we'll describe a couple of different ways you can build the test circuit.

MECHANICAL OPERATION OF THE SEIKO SHUTTER

Advance the shutter-cocking lever, Fig. 82, to cock the shutter. Notice that the opening-blade set, Fig. 84, doesn't move during the cocking cycle — it's already at the top of the aperture. But the closing-blade set, visible from the back of the shutter, moves up during the cocking cycle.

To release the shutter, push down the release lever, Fig. 84. The opening blade should then move down, uncovering the aperture. However, the closing blade should remain latched to keep the shutter open.

To free the closing blade, push the bulb lever out of engagement with the armature — from left to right in Fig. 84. The spring-loaded armature then moves away from the electromagnet and strikes the closing-blade latch. When the closing blade moves down to end the exposure, it strikes a latch holding the opening blade.

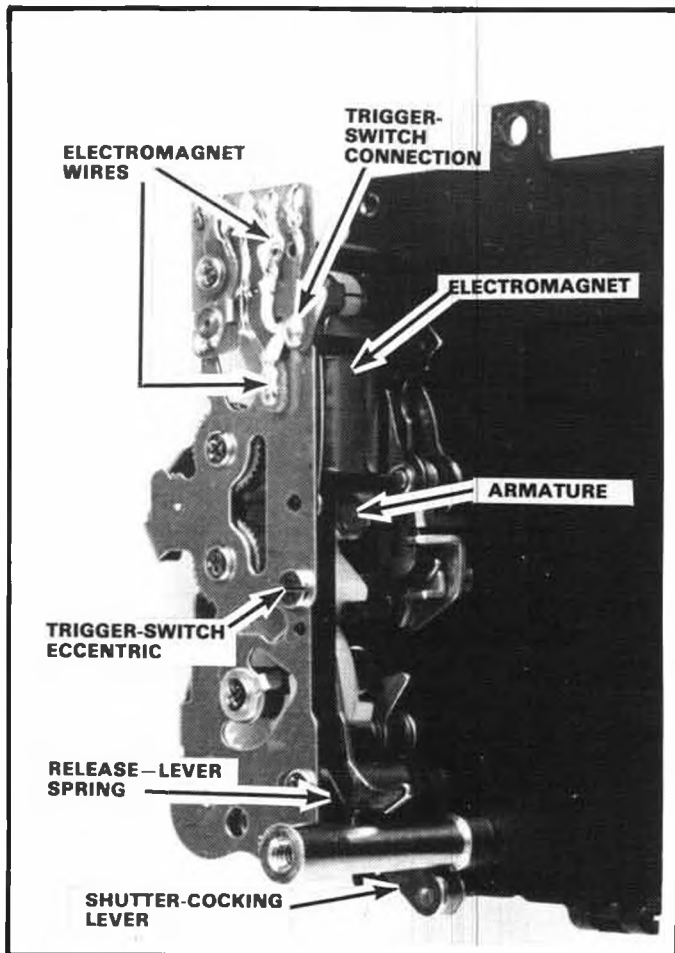

Figure 82

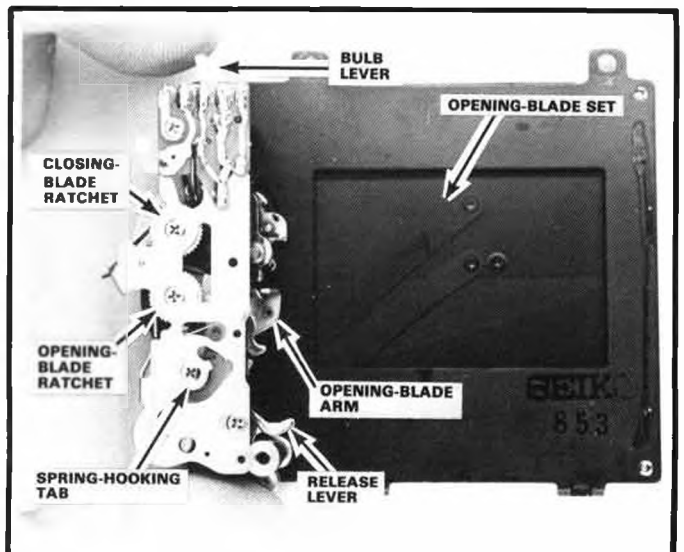

Figure 84

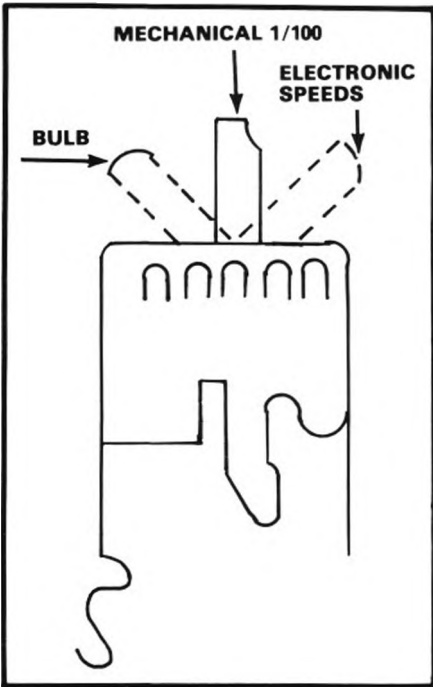

Figure 85

Now a spring drives the opening blade to the top of the aperture — back to the "ready" position. With the shutter released, both blades cover the aperture.

Since only one blade moves during the cocking cycle, the Seiko has a smooth

wind stroke which adapts well for use with a power winder. You can get a better idea of the operation if you try pulling down the arm on the opening-blade driving lever, Fig. 84, with the shutter in the released position. Pulling down the arm should move the opening blade to the bottom of the aperture. When you let go of the arm, the return spring drives the opening blade to the raised position.

Also try operating the shutter while you're holding the bulb lever fully clockwise, Fig. 85. You should then get the fast mechanical speed — somewhere between 1/1000 and 1/2000 second. Here, the bulb lever can't engage the armature. And, since there's no current through the electromagnet, the armature releases the closing blade immediately.

To set the 1/100-second mechanical speed, hold the bulb lever in its center position, Fig. 85. The bulb lever still can't engage the armature. But another lever — the mechanical-speed latch — holds the armature to provide the full-aperture speed.

The mechanical-speed latch sits just under the bulb lever, Fig. 86. When the opening blade crosses the aperture, it disengages the mechanical-speed latch. Now the armature frees the closing blade.

When the bulb lever moves to the electronic-speeds position — fully clockwise, Fig. 85 — it pulls the mechanical-speed latch away from the armature. Neither the mechanical-speed latch nor the bulb lever then has any effect on the operation.

REPLACING THE SHUTTER

In normal operation, the mechanical-speed lever, Fig. 87, controls the bulb lever. A cam under the shutter-speed resistor positions the mechanical-speed lever. Also note the tab on the release slide in Fig. 87. The tab pulls the bulb lever out of engagement to end the bulb exposure.

On reassembly, first cock the shutter. Then position the wires through the wire clamp, Fig. 80, as you seat the shutter on the mirror cage. Make sure that the bulb lever passes to the inside of the mechanical-speed lever, Fig. 87, and that the bulb-lever pin sits above the release-slide tab.

ADJUSTING THE BLADE-TRAVEL TIMES

Both blades should cross a 20mm distance in 6ms. To increase the tensions, rotate the blade ratchets, Fig. 84, in a

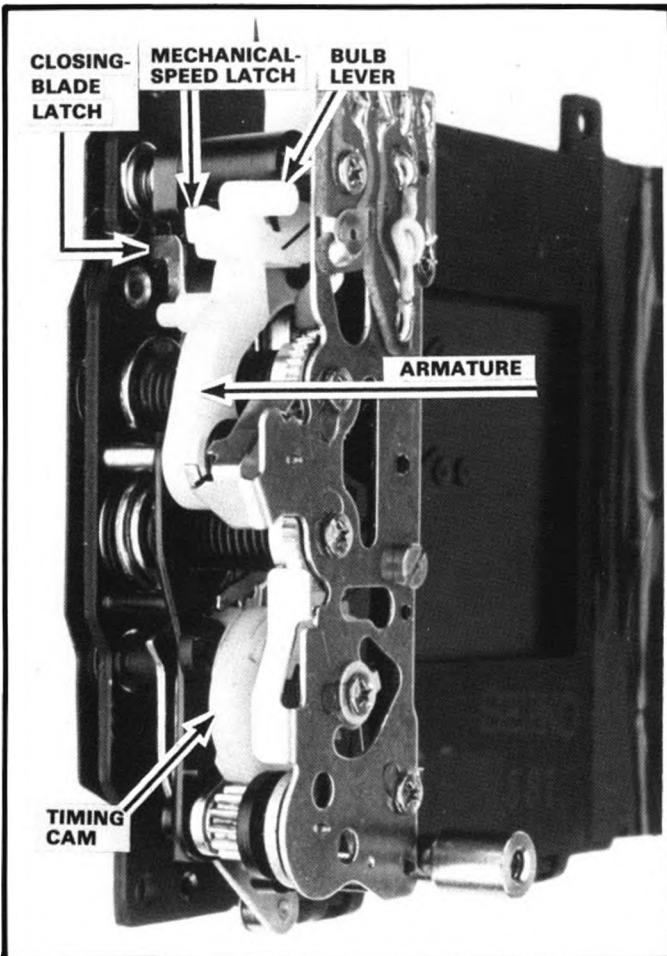

Figure 86

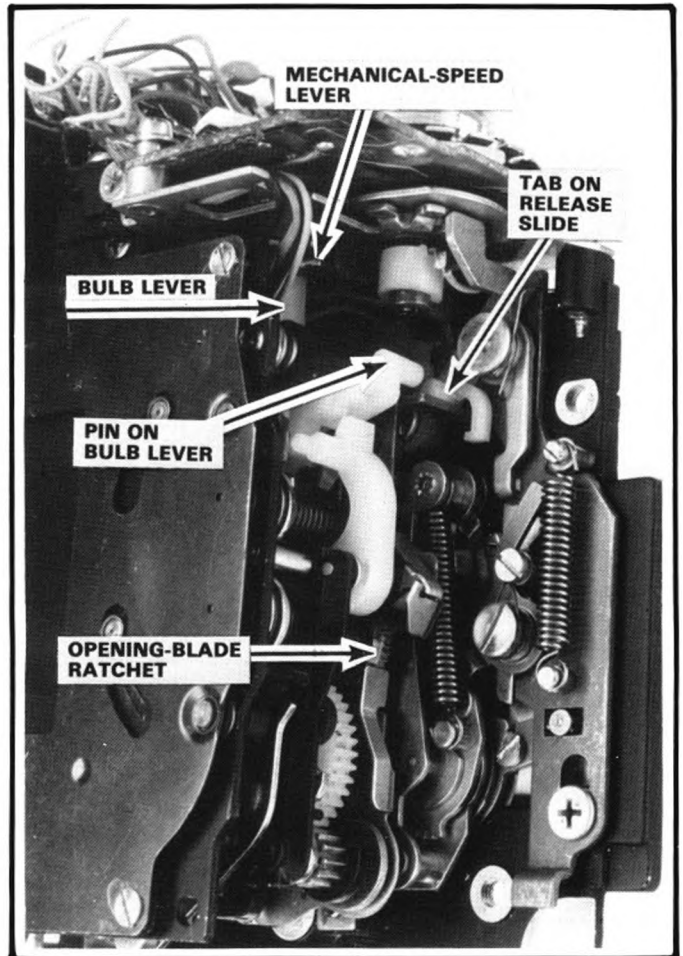

Figure 87

clockwise direction. However, to let off tensions, you must disengage the pawls from the ratchets.

In most cases, you'll be adding tension to speed up the blades. Rotating the opening-blade ratchet one click-stop in a clockwise direction increases the travel time by around 0.1ms. An increase of one click-stop on the closing-blade ratchet provides around a 0.2ms increase in the travel time.

It's a little more difficult to let off tension. Probably the easiest way is to simply disengage the appropriate spring pawl and allow the drive spring to completely unwind (around 1/2 turn). Then build up the tension from scratch.

Checking the travel times with the shutter removed presents another problem — it's awkward to hold the probe behind the blades as you operate the shutter. However, as you'll see in a moment, you can visually set the ratchets very close to the proper positions. You can then replace the shutter. Even with the shutter installed on the mirror cage, you can reach the tension-setting ratchets, Fig. 87.

Temporarily seat the front-plate/mirror-cage assembly in the body casting. Then, with the speed selector set at the 1/1000-second mechanical speed, measure the blade-travel times. Remembering the amount of correction you need, pull the front-plate/mirror-box assembly and make the adjustments. Suppose, for example, that you measure an opening-blade travel time of 6.2ms. You now know that you must add two clicks of tension to the opening-blade ratchet.

REPAIRS IN THE CONTROL SECTION OF THE SEIKO

Other than cleaning the blades, there aren't many common repairs in the Seiko shutters. If you're getting overexposures at high-light levels and fast manual speeds, try cleaning the surfaces of the electromagnet core and armature, Fig. 82. Oil on the interface causes sticking. As a result, the electromagnet can't release its armature quickly enough.

Also, you'll occasionally find that force has sheared off one of the pins in the shutter — either the pin on the shutter-cocking lever or the pin on the opening-blade driving lever. If you can find the missing pin, you can restake it to the lever. Otherwise, you'll have to replace a part.

Complete shutter disassembly does disturb some adjustment points. For one, you must let off the blade tensions. Also, you'll lose the initial tension on the timing cam, Fig. 86.

During the cocking cycle, the shutter-cocking lever rotates the timing cam in a clockwise direction. A cam ridge on the timing cam then allows the trigger switch to close. Also, the timing cam pushes the armature against the electromagnet, Fig. 82. At the end of the cocking stroke, the release lever latches the timing cam.

Disengaging the release lever frees the timing cam. A spring then drives the timing cam in a counterclockwise direction. The timing cam both releases the opening blade and drives open the trigger switch.

The spring which drives the timing cam connects to a spring-hooking tab on the bridge plate, Fig. 84. In the first Seiko shutters, such as the model illustrated, the spring-hooking tab is a separate piece. A screw holds the spring-hooking tab to the bridge plate.

After loosening the screw, you can rotate the spring-hooking tab to change the tension. Increasing the spring tension by turning the spring-hooking tab counterclockwise causes the timing cam to rotate faster. The result? A significant change in the fast speeds.

But don't use the spring-hooking tab as a shutter-speed adjustment. Rather, on reassembly, simply return the spring-hooking tab to its original position, Fig. 84. Notice that Seiko uses a locking agent on the spring-hooking tab and screw. If the screw works loose, the timing cam loses its spring tension. Consequently, the shutter won't release. In later shutters, Seiko made the spring-hooking tab part of the bridge plate.

If you don't change the initial tension on the timing-cam spring — and if you avoid disturbing the trigger-switch eccentric — you may find that you don't have to adjust 1/1000 second. You can also visually set the blade tensions according to the positions of the ratchets, Fig. 84. Returning the ratchets to their proper positions often brings in the blade-travel times without further adjustment.

On reassembly, rotate the ratchets clockwise to apply the initial tensions. Locate the spring-hooking slots in the sides of the ratchets. Rotate the closing-blade ratchet until its spring-hooking slot just reaches the edge of the bridge plate, Fig. 88. Then rotate the opening-blade ratchet until its spring-hooking slot just passes the bridge-plate cutout.

Here's another shutter problem you may encounter — the blades won't stay in the cocked position. First check the spring on the release lever, Fig. 84. If the spring comes disconnected, the release lever won't latch the timing cam. As a result, the blades won't latch in the cocked position — the timing cam immediately releases the opening blade. There should

be a dab of Pliobond between the end of the spring and the release lever.

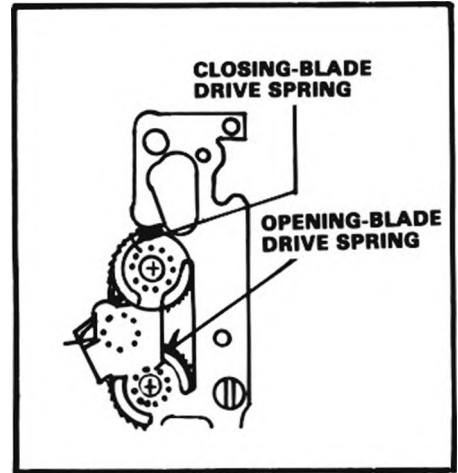

Figure 88

DISASSEMBLY OF THE SEIKO SHUTTER

Locate the two electromagnet lead wires which connect to the shutter-terminal board, Fig. 82. Both wires are the same color — normally white, but sometimes green or red. Unsolder both wires. Also unsolder the end of the trigger switch from the shutter-circuit board, Fig. 82. You'll probably find that it's easier to unsolder the trigger switch as you lift the shutter-terminal board from the bridge plate.

Remove the screw and lift off the shutter-terminal board. On the back of the shutter-terminal board, you can see the X-sync contact. The lever which disengages the mechanical-speed latch for the mechanical 1/100-second exposure also strikes the X-sync contact to fire the flash.

Now disengage the spring pawls to let off the blade tensions. Also loosen the screw which holds the spring-hooking tab, Fig. 84. Allow the timing-cam spring to rotate the spring-hooking tab in a clockwise direction. Then remove the screw and lift out the spring-hooking tab. If you're working on a later version of the shutter, just disconnect the timing-cam spring from the tab on the bridge plate.

To replace the spring-hooking tab, first locate the end of the timing-cam spring. Seat the spring-hooking tab clockwise of the spring end. Then replace the screw. Before you tighten the screw, rotate the spring-hooking tab counterclockwise to the position shown in Fig. 84.

There are two more springs to disconnect before you remove the bridge plate. Disconnect the armature spring from the bridge-plate tab, Fig. 86, and disconnect the spring from the release lever, Fig. 84. Now remove the remaining bridge-plate screws.

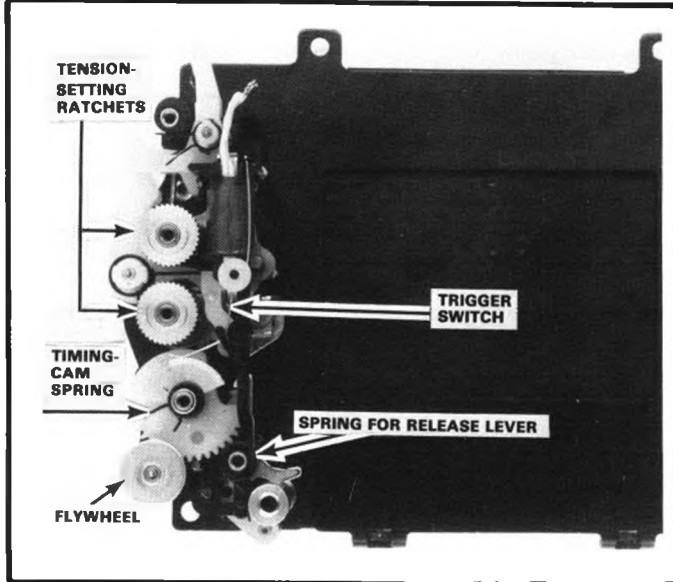

Figure 89 Released position

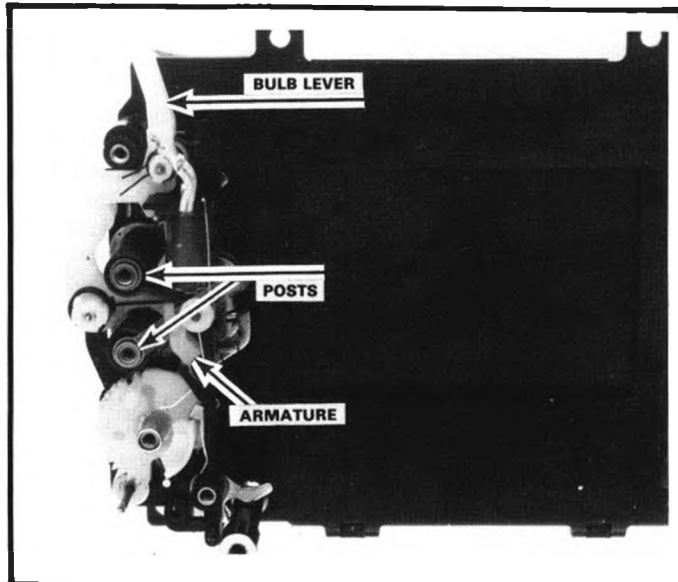

Figure 90 Cocked position

Be careful as you lift off the bridge plate — several shutter parts are loose, Fig. 89. In early shutters, you can lift out the loose flywheel which engages the timing cam. Later models changed the flywheel design; you can't take out the later-style flywheel until you remove the timing cam.

Also lift out the timing-cam spring and the spring for the shutter-release lever, Fig. 89. Notice that the lower end of the timing-cam spring sits within a slot in the timing cam. The straight end of the spring for the shutter-release lever sits against a pin on the magnet bridge, the plastic support for the electromagnet.

Next lift out the two tension-setting ratchets. The slots in the ratchets fit over the upper ends of the blade-drive springs. In early shutters, the posts passing through the centers of the blade-drive springs are also loose, Fig. 90. In later shutters, the posts are formed on the ratchet gears.

With the loose parts removed, you can safely operate the shutter. Note the position of the trigger-switch blade in Fig. 89. A washer holds the trigger-switch blade on the magnet bridge. The upper end of the trigger-switch blade connects to the shutter-terminal board; the lower end rests against the cam ridge of the timing cam.

Remember, the timing cam rotates clockwise during the cocking cycle. The cam ridge then allows the trigger-switch blade to move from left to right, Fig. 90. So, with the shutter cocked, the trigger-switch blade moves against the eccentric pin on the bridge plate. The trigger switch now connects the orange-wire terminal of the shutter-terminal board to ground.

In Fig. 90, you can also see how the timing cam drives the armature against

the electromagnet. A roller on the armature rides against the outer edge of the timing cam. As long as the timing cam remains latched by the shutter-release lever, it holds the armature against the electromagnet.

Disengaging the shutter-release lever allows the spring-loaded timing cam to rotate counterclockwise. A cutout in the outer edge of the timing cam then frees the armature, Fig. 89. It's now up to the electromagnet, the bulb lever, or the mechanical-speed latch to hold the armature and prevent the closing blade from releasing.

Also, the ridge on the timing cam drives the trigger-switch blade away from the eccentric pin. Disconnecting the trigger-switch blade from ground opens the trigger switch. Toward the end of the rotation, the timing cam strikes the opening-blade latch to release the opening blade.

On reassembly, rotate the timing cam to the released position, Fig. 81, before you replace the bridge plate. The trigger-switch blade then clears the eccentric pin.

But rotate the timing cam to the cocked position, Fig. 90, to remove or to replace the trigger-switch blade. Remove the trigger-switch blade by lifting off the insulating washer. Notice that each end of the trigger-switch blade passes through a slot in the plastic magnet bridge.

Take out the bulb lever by first disconnecting its spring, Fig. 90. Then lift the bulb lever up and off the magnet-bridge post. If you just want to lift off the magnet bridge, you can leave the bulb lever and the remaining parts in place. However, if you're replacing the electromagnet, also remove the timing cam, the armature, and the mechanical-speed

latch. The replacement electromagnet and the magnet bridge come as one assembly.

Before you remove the magnet bridge, though, you might note one more timing point — that of the timing cam. Even if you leave the timing cam in place, it's possible to lose the timing. The timing cam may lift up slightly, thereby allowing its pinion to disengage from the set gear, Fig. 91.

The set gear is the gear segment under the timing cam. As you cock the shutter, a pin on the shutter-cocking lever comes against the right-hand edge of the set

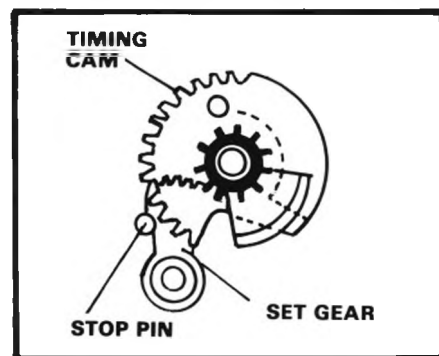

Figure 91

gear. The shutter-cocking lever then drives the set gear in a counterclockwise direction. In turn, the set gear rotates the timing cam clockwise.

If you hold the shutter-cocking lever fully advanced, the left-hand edge of the set gear comes against a stop pin on the magnet bridge, Fig. 91. The timing cam should now be in the position shown in Fig. 91; notice that the first tooth of the timing cam points to the pivot post for the inertia flywheel. If the timing isn't right, lift the timing cam far enough to disengage the set gear. Then, with the set gear against the stop pin, position the

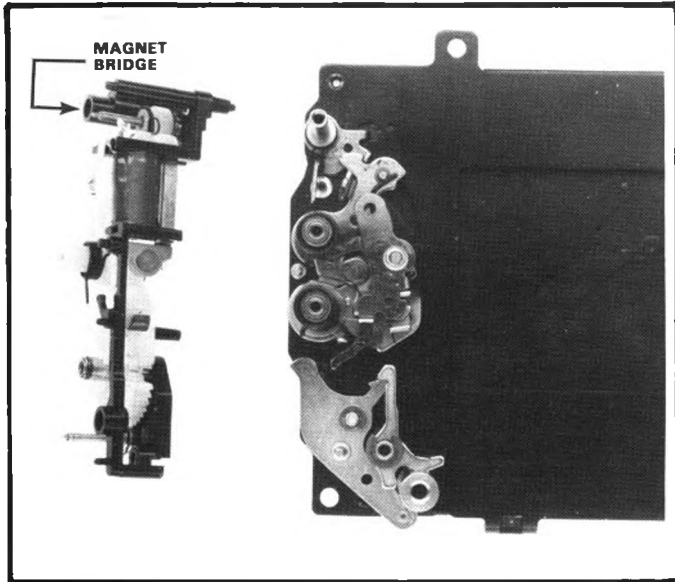

Figure 92

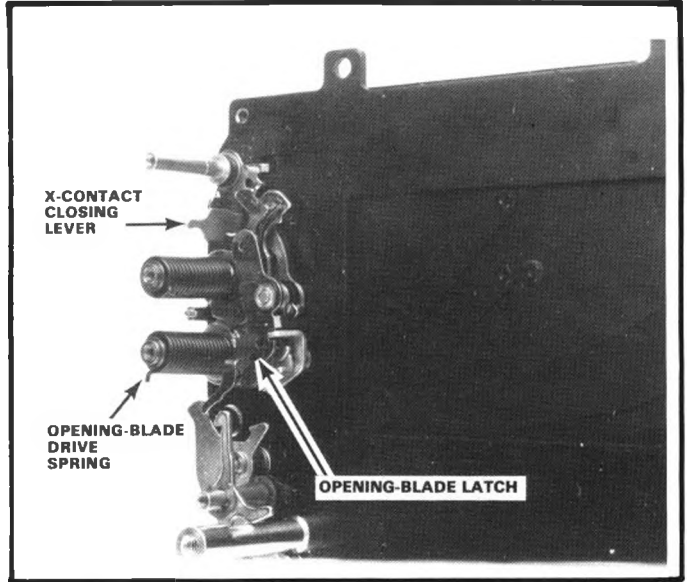

Figure 93

timing cam as shown in Fig. 91.

You can now lift out the magnet bridge, Fig. 92. Also lift out the opening-blade drive spring, Fig. 93. The longer end of the opening-blade drive spring goes down and hooks against a tab on the opening-blade driving lever. Leave the closing-blade drive spring in place.

To remove the opening-blade latch, first disconnect its spring from the tab on the X-contact closing lever, Fig. 93. Then lift the opening-blade latch up and off its post. The spring stays on the opening-

blade latch.

At this point, you can more easily observe the operation of the blade assemblies. Be careful, though, that you don't lift up the blade-driving levers. If you do, the pins on the other sides of the blade-driving levers will come out of the slots in the blade sets. Then, if the individual blades shift in position, you'll have to realign the slots before you can replace the blade-driving levers.

Fig. 94 and Fig. 95 show how the blade-driving levers operate. As you cock

the shutter, the shutter-cocking lever comes against a roller on the opening-blade driving lever (this roller is the part that may be sheared off if the shutter has been forced). The shutter-cocking lever now pushes up the opening-blade driving lever. In turn, the opening-blade driving lever pushes up the closing-blade driving lever. With the shutter cocked, the opening-blade latch, Fig. 93, engages the opening-blade driving lever and the closing-blade latch, Fig. 95, engages the closing-blade driving lever.

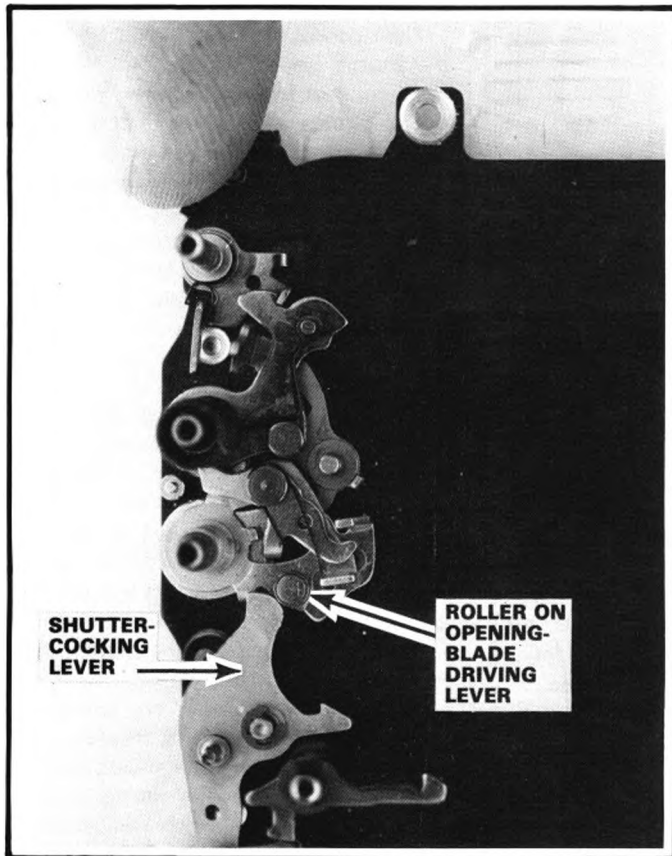

Figure 94

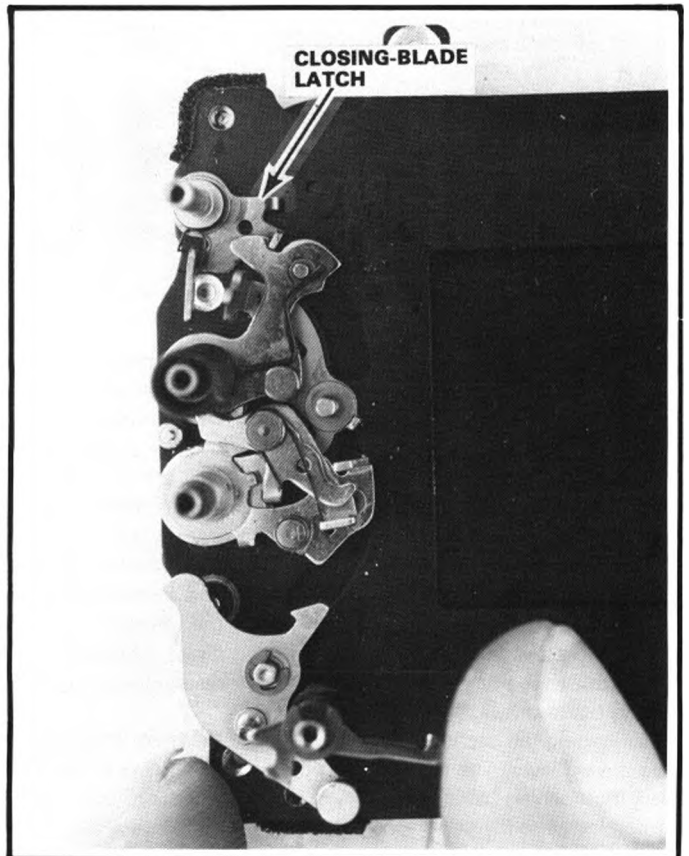

Figure 95

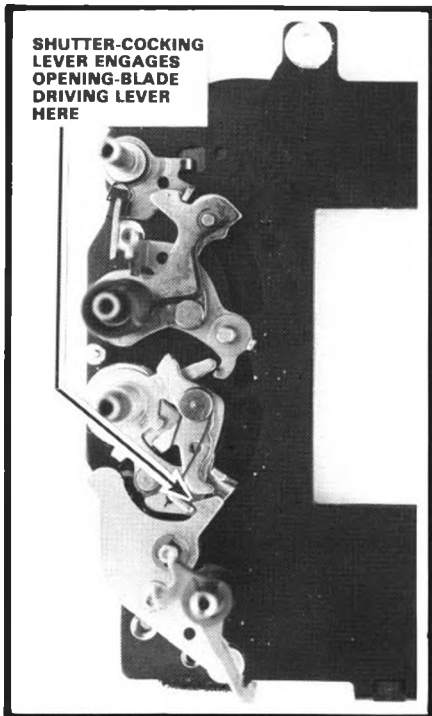

Figure 96

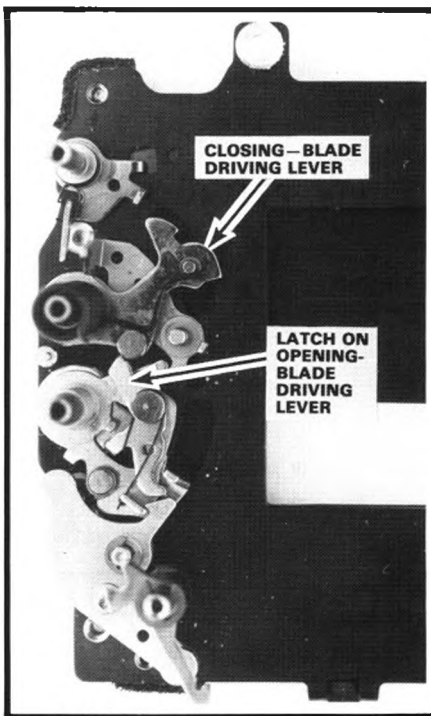

Figure 97

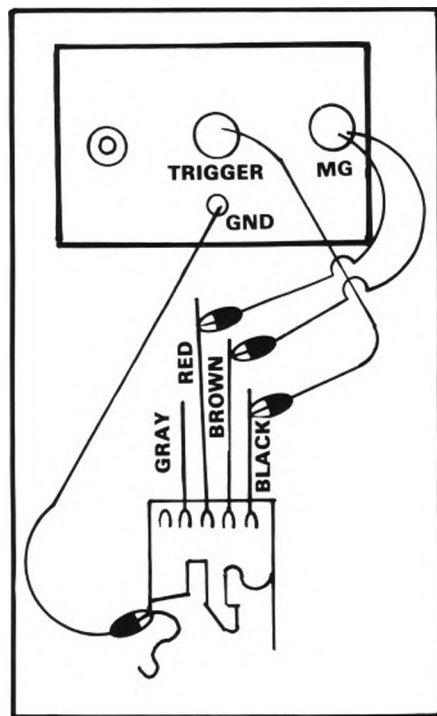

Figure 99

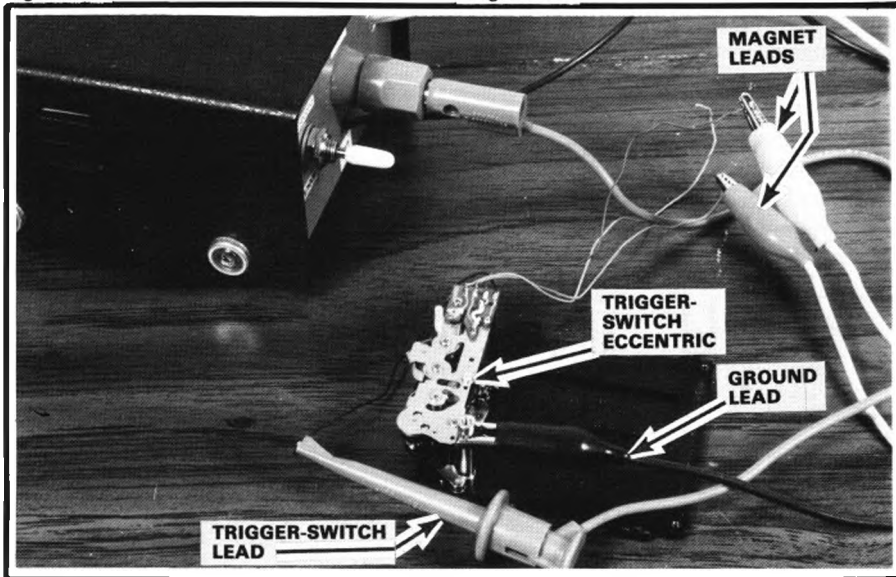

Figure 98

Simulate the release action by pulling down the opening-blade driving lever, Fig. 96. As the opening-blade set moves down, it uncovers the aperture. The shutter-cocking lever then latches and holds the opening-blade driving lever, Fig. 96.

Next disengage the closing-blade latch and pull down the closing-blade driving lever. When the closing-blade driving lever reaches the position shown in Fig. 97, it strikes the latch on top of the opening-blade driving lever.

Disengaging the latch frees the opening-blade driving lever. The return spring then drives the opening-blade driving lever in a counterclockwise direction. And the opening blade returns to the raised position, covering the focal-plane aperture.

On reassembly, leave the shutter dry — no lubrication. Remember, oil quickly works its way to the shutter blades and to the electromagnet. Also, before you install the shutter on the mirror cage, you might double-check the operation of the trigger switch. Connect an ohmmeter between the black-wire terminal, Fig. 81, and a metal portion of the shutter. With the shutter cocked, you should read direct continuity. You should read infinite resistance with the shutter released.

TIMING CIRCUIT FOR ADJUSTING THE SEIKO SHUTTER

Earlier, we mentioned that you can build a timing circuit for adjusting the trigger switch. Just connect the timing circuit to the shutter's lead wires as shown

in Fig. 98. There's only one problem — you disconnect the shutter leads to remove the shutter.

If you're also removing the flex circuit, you can leave the shutter leads connected to the shutter-terminal board, Fig. 98. Disconnect the other ends of the wires from the flex. Otherwise, you'll have to temporarily solder wires to the shutter-terminal board.

Then connect the test-circuit leads to the shutter leads, Fig. 99. The magnet leads connect to the two wires going to the electromagnet — red and brown. Now the test circuit supplies the power to hold open the shutter. The trigger-switch lead connects to the wire going to the trigger switch, and the ground lead connects to any metal part of the shutter.

The trigger-switch lead and the ground lead now connect across the shutter's trigger switch. Remember, the trigger-switch eccentric pin is a ground connection. In some Seiko shutters, however, you'll find that the eccentric pin does not connect to ground. Instead, a separate wire goes to the eccentric pin. In that case, connect the trigger-switch lead of the test circuit to one of the wires going to the trigger switch; connect the ground lead to the second trigger-switch wire.

When you now release the shutter, the trigger switch tells the timing circuit to start timing the exposure. You can then use a shutter-speed tester to measure the exposure time. The shutter should deliver 1/1000 second with the timing circuit connected. If not, simply adjust the trigger-switch eccentric, Fig. 98.

The timing circuit in the test box

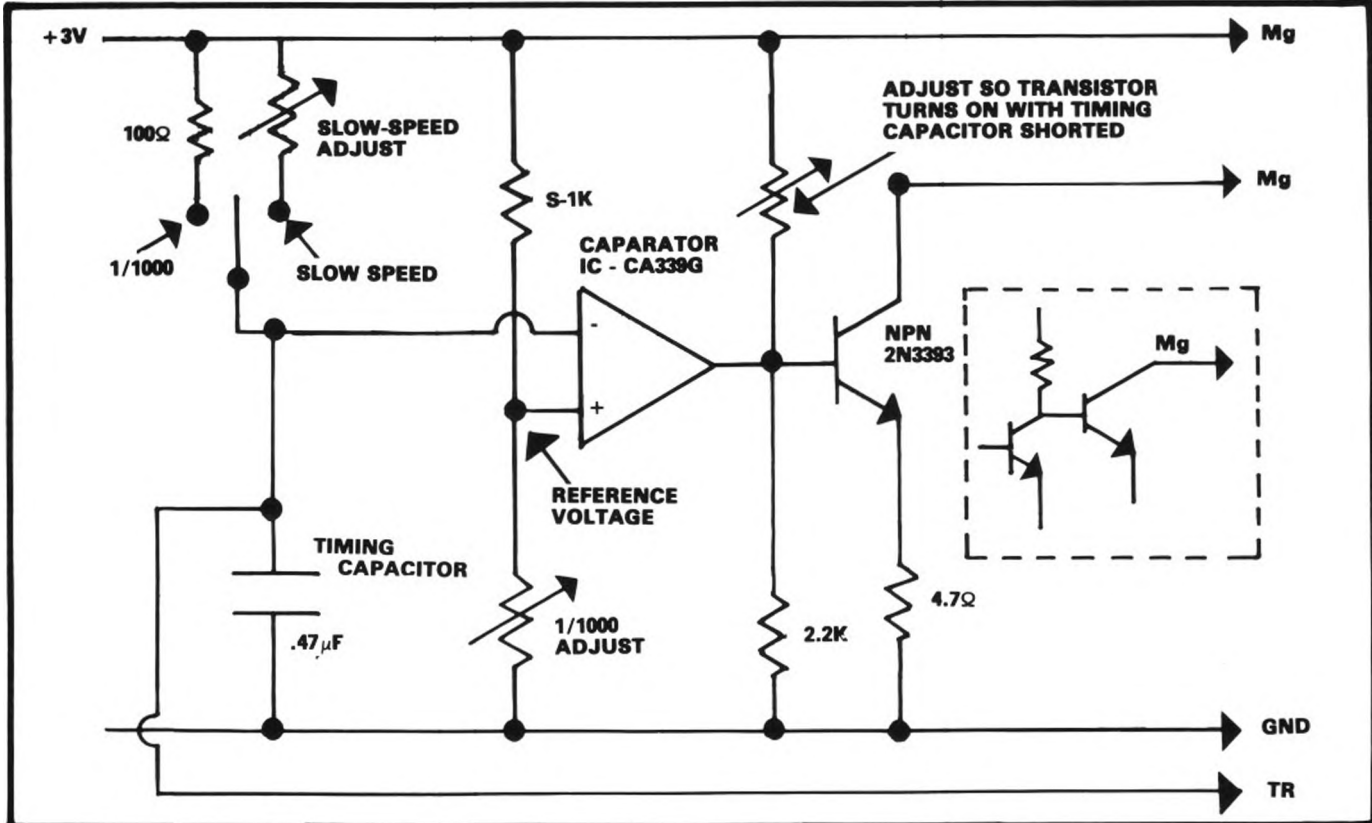

Figure 100

simulates the camera's timing circuit at the 1/1000-second setting. There are several ways you can build such a timing circuit. Fig. 100 illustrates one method. You should have no trouble in obtaining the components from any electronics supplier.

Although you could build the power supply into the test box, we've designed the circuit of Fig. 100 to be used with a separate 3V DC power supply. Notice that the magnet lead connects to the collector of a switching transistor. A comparator controls the signal at the transistor base. When the output of the comparator goes high, the transistor switches on. The transistor then conducts current through the shutter's electromagnet.

The trigger switch of the shutter connects to the timing capacitor of the timing circuit. With the shutter cocked, the closed trigger switch shorts the timing capacitor to ground. Then, when you release the shutter, the trigger switch opens and allows the timing capacitor to start charging.

When the timing capacitor reaches the reference voltage, the comparator switches states — the output goes low to shut off the transistor. In turn, the transistor shuts off the current through the shutter's electromagnet. In Fig. 100, we've provided a variable-resistor adjustment to establish the reference voltage at the noninverting input of the comparator. Use the variable resistor to adjust the timing circuit for 1/1000 second.

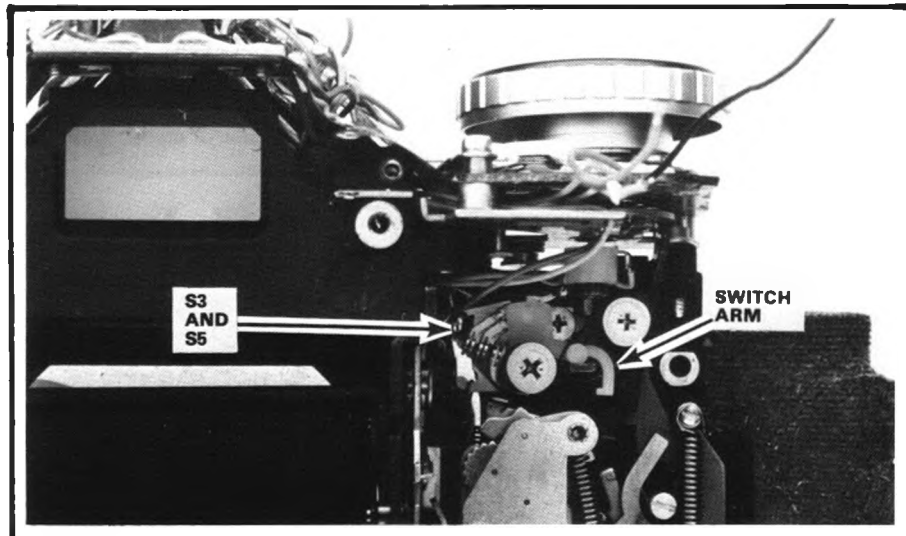

Figure 101

We've also provided a second speed in Fig. 100. As mentioned earlier, the slower shutter-speed setting serves as an operational check. You may wish to set the second speed for 1/100 second, the full-aperture speed. That way, you can also use the test box for checking X-sync operation.

Rather than the comparator IC, you may prefer to use a two-transistor switch as shown in the inset, Fig. 100. Connect the base of the second transistor to the timing capacitor. By using a variable resistor to control the capacitor-charge time, you can adjust the test circuit for 1/1000 second.

ADJUSTING THE RELEASE SWITCH AND THE METERING SWITCH

There's another reason for removing the shutter — to reach the release switch S3 and the metering switch S5, Fig. 101. Earlier, we described how you can check the two switches without disassembly. However, if you pinpoint the problem to one of the switches, lift aside the shutter to make the repair (you don't have to disconnect the shutter wires to adjust and clean the switches).

A sliding brush contact, Fig. 101, closes both switches as you depress the release slide. The brush first connects the green-wire land to ground, thereby clos-

ing the metering switch S5. Next the brush connects the orange-wire contact to ground to close the release switch S3.

As noted during the troubleshooting, suspect S5 if pushing the release button part way fails to turn on the LED display. Suspect S3 if the shutter won't release at the electronic settings. You can now clean the brush contact and the switch-board lands.

But, if you remove the switches for cleaning, you'll have to readjust the switch board. Adjust the switch timing by first loosening the two screws — one holding the brush and one holding the switch board, Fig. 101. Then shift the position of the switch board to set the amount of release-slide movement needed to close each switch.

Check the metering switch S5 first. Connect an ohmmeter between the green wire and ground. Then slowly depress the release button. When the release slide moves down 0.4mm, the metering switch should close. Your ohmmeter should then show direct continuity between the green wire and ground.

To check the release switch, make sure you've set the speed knob to an electronically controlled speed. Then connect your ohmmeter between the orange wire and ground. The release switch should close when the release slide moves down 1mm.

Double-check the switch timing by setting a mechanical speed — 0 or B. The

release-slide latch now moves out of the path of the release slide. As the brush starts to rotate clockwise, the release-slide latch blocks the switch arm, Fig. 101.

The brush should still rotate far enough to close the metering switch. However, the release-slide latch should block the brush rotation before the release switch closes.

So, with your ohmmeter connected between the orange wire and ground, depress the release button. The release switch should not close — no matter how far down the release slide moves. Then check the metering switch between the green wire and ground. The metering switch should close when the release slide moves down 0.4mm.

REMOVING THE FLEX CIRCUIT

Other than for replacement purposes, there aren't too many reasons to remove the flex circuit. The complete flex circuit does come as a replacement part (flexible circuit base plate, A set — 0841). A replacement flex includes the RTV (shutter-speed) resistor, but not the diaphragm resistor or the SPD board. There's also an exchange program. If you send in the old flex circuit, you can get the replacement for about half price.

Fig. 102 shows the wiring pictorial for the flex circuit. If you know beforehand that you're going to remove the flex circuit, leave the shutter in place. You can

then disconnect the shutter wires from the flex circuit rather than from the shutter-terminal board. But watch for wiring variations. In earlier versions of the flex circuit, you'll find slight variations in the physical positions of the wires.

The wires from the shutter-terminal board, the release switch, and the metering switch pass through the flex-circuit slot. Unsolder the green S5 wire, the orange S3 wire, the red magnet wire, the brown magnet wire, and the black trigger-switch wire. Also unsolder the two gray wires from the sync pin, Fig. 102. It's not necessary to unsolder the blue wire that passes through the flex-circuit slot; the blue wire connects S11 to pin 12 of IC1.

Now unsolder the seven connections to free the flex strip of the diaphragm resistor, Fig. 102, and unsolder the four wires at the side of the mirror cage — blue, orange, pink, and violet. Also, if you're replacing the flex circuit, unsolder the wires that connect the SPD board to the flex, Fig. 102. Unsolder the wires from the flex, not from the SPD board. Disconnect the SPD board from the flex by unsoldering the connection shown in Fig. 103. However, if you're not replacing the flex, leave the SPD board connected — you can remove the flex and SPD board as a unit.

To remove the speed selector, you'll have to disconnect the tungsten wire that

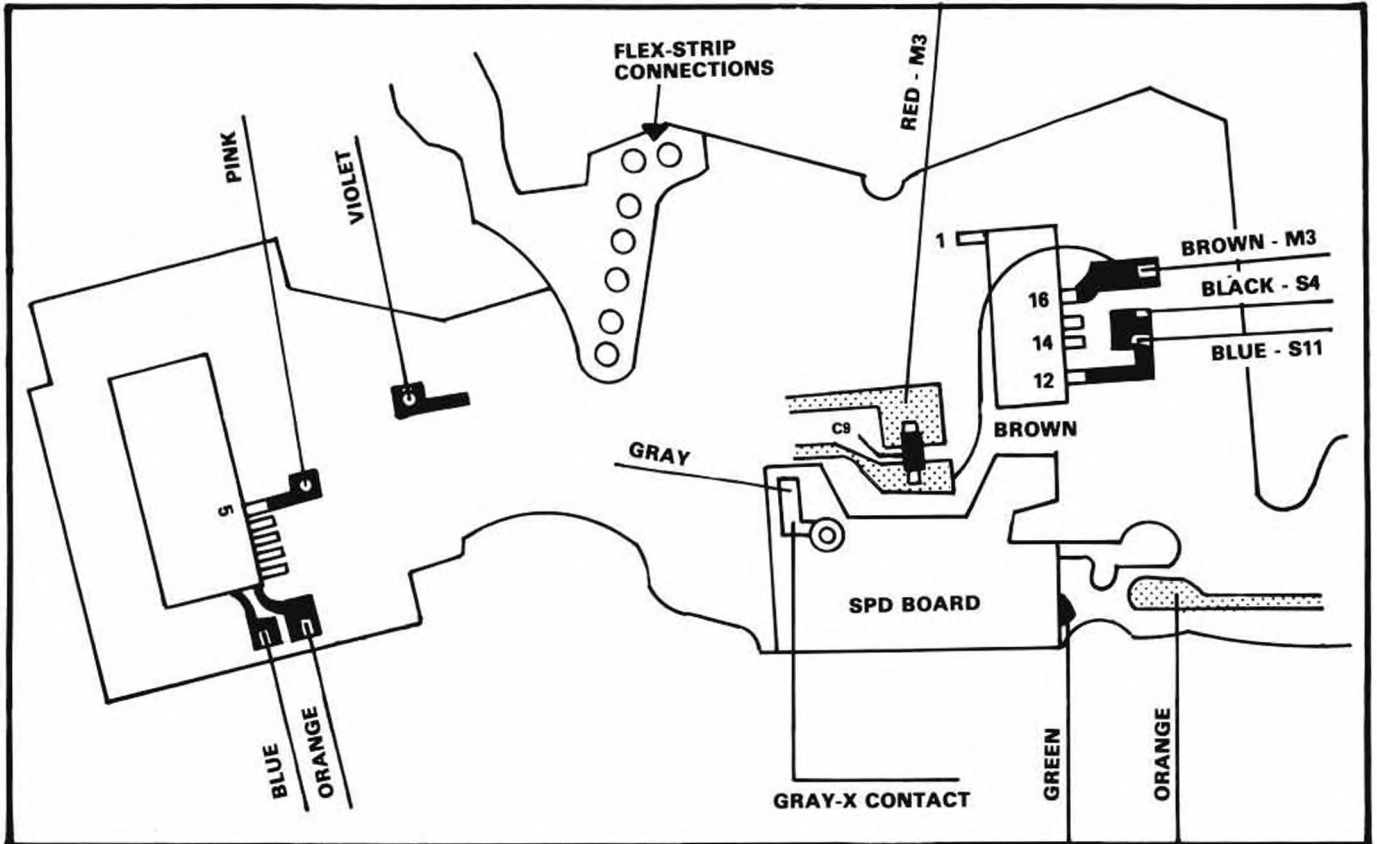

Figure 102

controls the shutter-speed scale. First set the 0 shutter-speed setting, Fig. 103; that lets off most of the initial tension. Remove the speed knob and unscrew the nut holding the speed selector. Then, as you lift off the speed selector, disconnect the tungsten wire from the adjustment collar, Fig. 103. Careful — the ball detent and compression spring for the speed selector will be loose. We'll describe the procedure for reconnecting the tungsten wire during reassembly.

Now take out the two screws holding the pulley bracket, Fig. 103. Watch for the loose spacer under one end of the bracket (the end closer to the back of the camera). Now lift out the mask lever, Fig. 103, and disconnect the wire link that runs between the mask lever and the viewfinder mask.

Remove the complete flex circuit by taking out the two screws holding the RTV resistor, the two screws holding the SPD board, and the two ground screws at the side of the mirror cage. At the back of the flex circuit, you can now see the LED display and IC2, Fig. 104.

If you just want to check IC2, you can reach the IC without completely removing the flex circuit. Take out the two ground screws at the side of the mirror cage. Then lift the LED base plate, Fig. 104, far enough from the mirror cage to reach the IC. Suppose, for example, that you're getting no LED readout. You might check for 3V at pin 2 of IC2, Fig. 104, with the release button partially depressed.

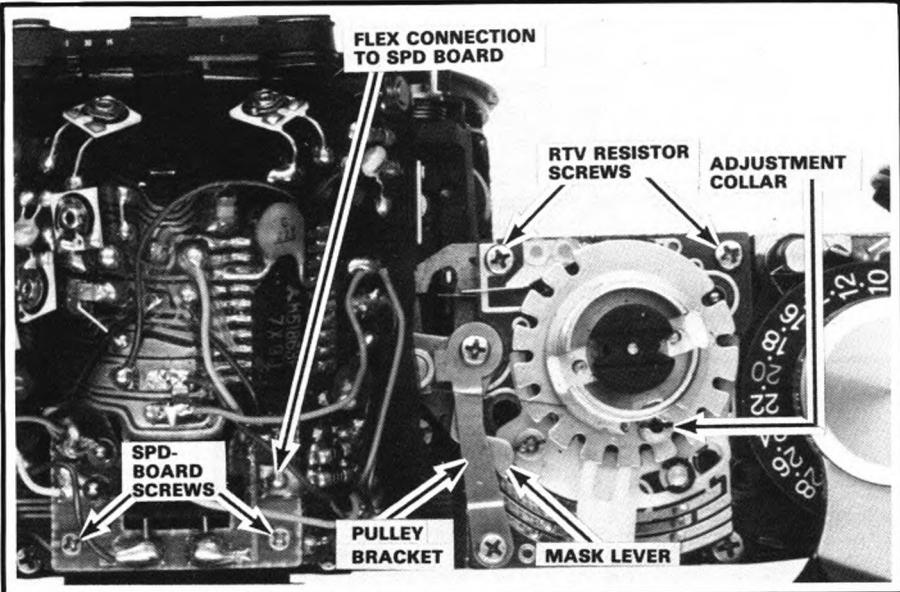

Figure 103

It's also possible to check the individual LEDs without removing the flex circuit completely. Fig. 104 points out the hole that receives the ground screw. Connect a jumper between the ground land at the other side of this hole and the front plate. Then push the release button part way to supply the LED anode voltages.

If you now short between a cathode lead and ground, Fig. 104, the LED connected to that output should turn on. What if it doesn't? The particular LED may not be getting the 3V anode voltage (you can check the anode voltages after removing the plastic cover over the LED display). Or the LED may be defective. However, you can't get the LED base plate as a separate part. A defective LED requires replacing the complete flex circuit.

Fig. 105 shows the top of the shutter/

mirror-cage assembly after removing the flex circuit. Notice that the speed-control cam is now loose. In Fig. 105, you can see how the speed-control cam positions the mechanical-speed lever (the lever that controls the shutter's bulb lever). A pin on the mechanical-speed lever rides against the speed-control cam. The pin on the underside of the speed-control cam positions the release-slide latch.

MIRROR-CAGE REPAIRS

For most of the mechanical repairs on the mirror cage, you don't have to remove either the flex circuit or the shutter. In fact, you may not even have to remove the mirror cage from the body casting. If the problem is in the air cylinder or the memory-time-lag adjust-

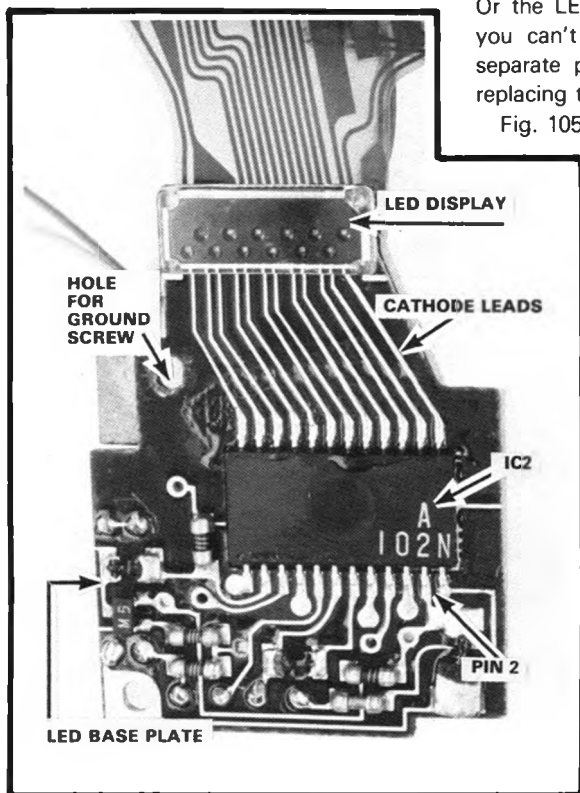

Figure 104

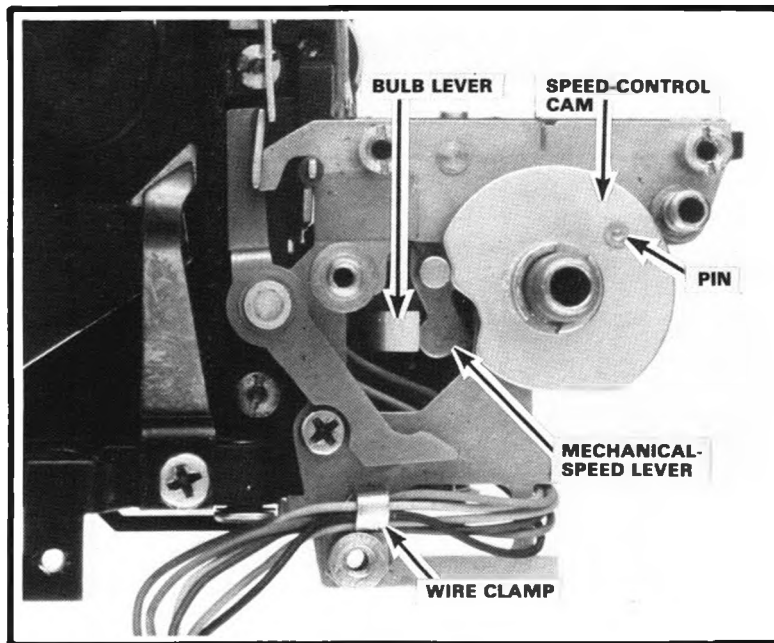

Figure 105

ment, you can usually make the repair without pulling the mirror cage.

Earlier, we mentioned that the air piston on the side of the mirror cage provides the memory time lag. The air piston actually releases the mirror. When the mirror-release magnet disengages the mirror-release lever, Fig. 106, the spring-driven piston moves down. The piston then disengages the mirror-lifting lever.

You can adjust the memory time lag by turning the setscrew at the top of the air

cylinder, Fig. 107; you don't even have to remove the mirror cage to reach the adjustment. Turning down the setscrew increases the pressure of the spring inside the cylinder. The spring then drives down the piston more quickly, resulting in a shorter delay between the closing of the release switch and the opening of the memory switch.

The time delay assures that the diaphragm reaches the taking aperture before the memory switch opens. Minolta

specifies a 56ms delay between the two switching actions. Too short a memory time lag results in inaccurate exposures; the memory switch opens before the diaphragm has time to reach the selected aperture.

You may never have to adjust the memory time lag. But, in some situations, you may be able to trace the problem to the air cylinder. For example, if the owner shoots pictures at high altitudes, the decreased air pressure within the cylinder

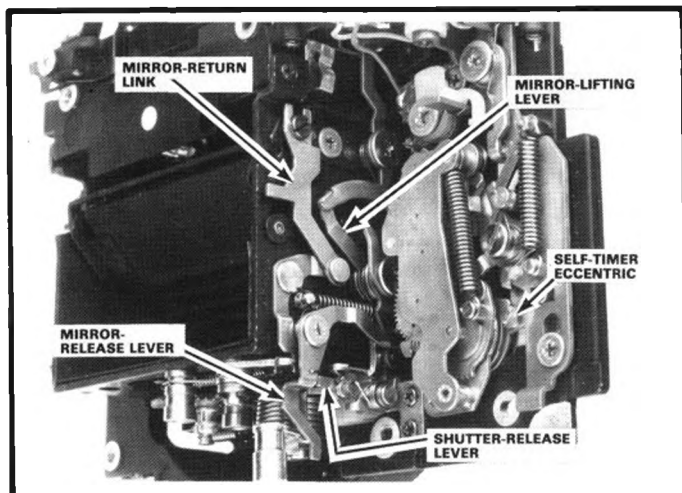

Figure 106

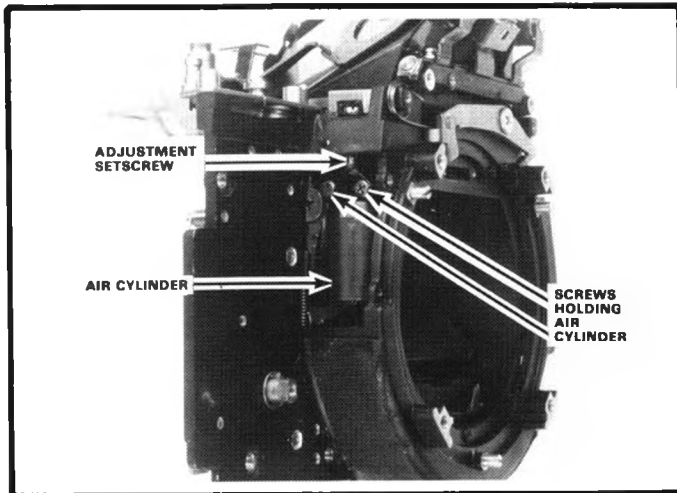

Figure 107

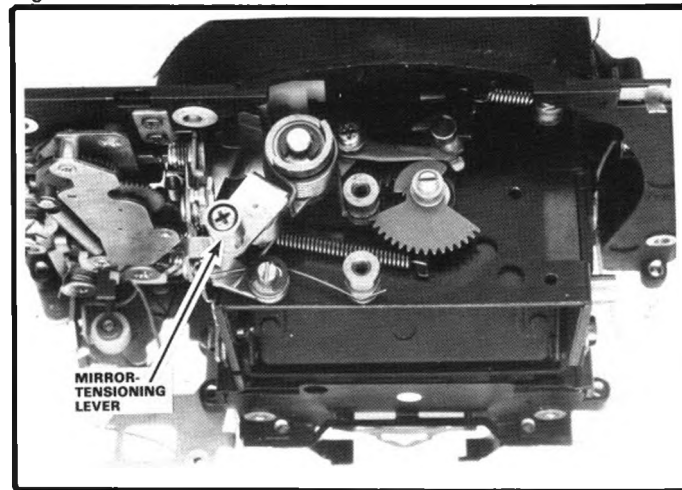

Figure 108

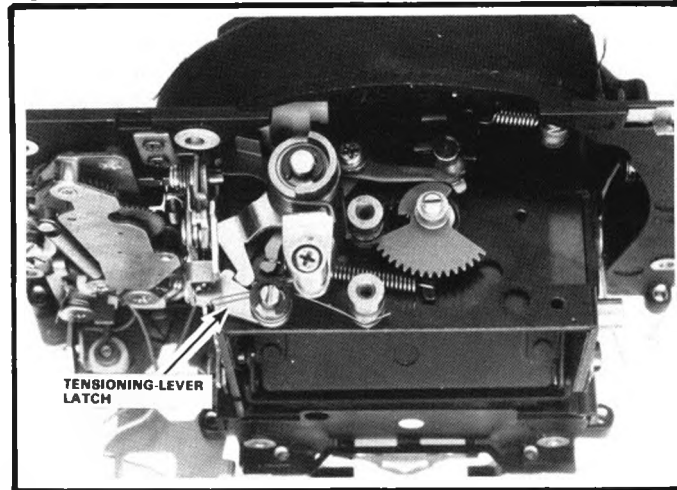

Figure 109 Mirror charged

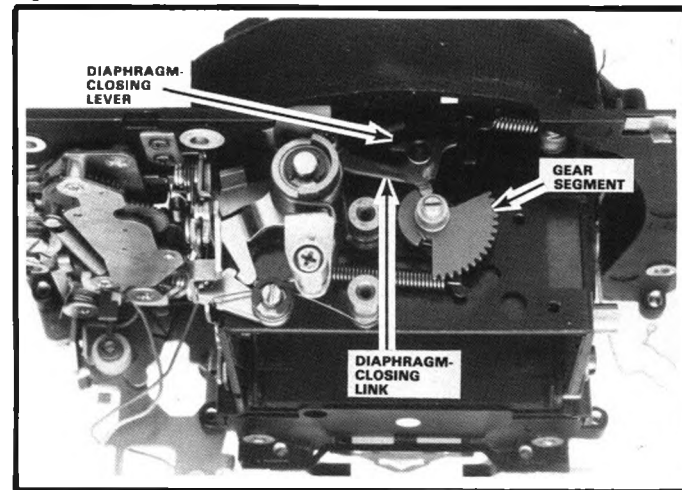

Figure 110 Mirror up

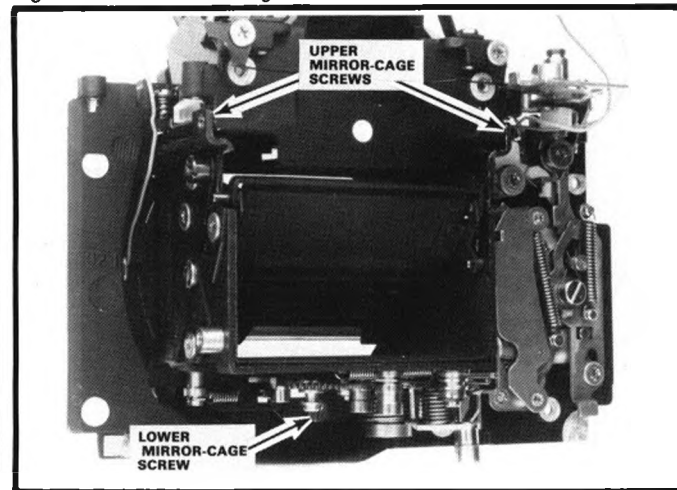

Figure 111

may allow the piston to move too quickly. Since the memory time lag is then too short, the owner gets inaccurate or erratic exposures at auto. Yet, at normal altitudes, the camera tests perfectly.

Dirt in the air cylinder can also cause problems — even a failure of the mirror to release. You can remove the air cylinder for cleaning without taking out the mirror cage. Just remove the two screws holding the air cylinder; reach the screws through the cutout at the side of the lens mount, Fig. 107. But be careful — both the air piston and the compression spring inside the cylinder will be loose. After you clean the parts, wipe the inside of the air cylinder with a thin coat of shutter oil.

In an earlier *Craftsman* article, we described the technique for measuring the memory time lag using an oscilloscope. The technique involves connecting the vertical input of the scope between the release switch and the memory switch. Also short across the memory capacitor. When you then release the shutter at the X setting, you can measure the length of time that the trace stays at 0V — that's the memory time lag.

But you don't have to rush out and buy an oscilloscope to repair the XD-11. For one thing, adjusting the memory time lag isn't a common repair. And, if necessary, you can adjust the memory time lag by making repeated auto-exposure tests. Remember, an inaccurate memory time lag causes erratic and incorrect exposures. So, by turning the setscrew, you can change the memory time lag until the

auto exposures are consistent and correct. If you do turn the setscrew, Fig. 107, lock the adjusted position with cement.

The more common mechanical repairs involve the levers at the bottom of the mirror cage, Fig. 108. For example, you may find that the camera works properly with the lens removed. However, as soon as you install the lens, the camera jams. What happens is that the diaphragm fails to reopen after the exposure — usually because the mirror-tensioning lever, Fig. 108, isn't moving freely.

In Fig. 108, we've removed the two combination magnets at the bottom of the mirror cage. Remember, though, that removing the combination magnets requires that you readjust their positions on reassembly. You can now see the diaphragm-control parts.

The mirror-tensioning lever moves to the charged position, Fig. 109, when you cock the shutter. Notice in Fig. 109 that the tensioning-lever latch now engages the mirror-tensioning lever. Then, when the mirror-release magnet disengages the mirror-release lever, Fig. 106, the diaphragm-closing link pulls the diaphragm-closing lever from right to left, Fig. 110.

Also, the diaphragm-closing link rotates the gear segment, Fig. 110, in a counterclockwise direction. The gear segment then turns the ratchet gear (remaining with the diaphragm-control magnet). Stopping the ratchet gear arrests the movement of the gear segment. In turn, the gear segment stops the travel of the

diaphragm-closing link.

After the exposure, the shutter mechanism pushes down the mirror-return link, Fig. 106. The mirror-return link now disengages the tensioning-lever latch from the mirror-tensioning lever, Fig. 108. As the mirror-tensioning lever moves clockwise, it drives the diaphragm-closing link back to its original position.

So, if the diaphragm won't reopen after the exposure, suspect the mirror-tensioning lever. Dirt may be preventing free travel. As a result, the mirror-tensioning lever can't push the diaphragm-closing link against the spring tension of the lens.

For major repairs, you may have to separate the mirror cage from the front plate. Take out the two upper mirror-cage screws, Fig. 111, and the large screw at the bottom of the mirror cage. Then separate the mirror cage from the front plate.

You can now get a better idea as to the mirror-release action. Notice in Fig. 112 how the memory-switch lever latches the mirror-lifting lever. The damper link now holds the air piston within the air cylinder — against the pressure of the compression spring.

When the mirror-release lever frees the diaphragm-closing link, it also frees the damper link. The spring-loaded piston then moves down, driving the damper link in a clockwise direction, Fig. 113.

Now the damper link strikes the memory-switch lever, Fig. 113. As the upper end of the memory-switch lever swings toward the back of the mirror

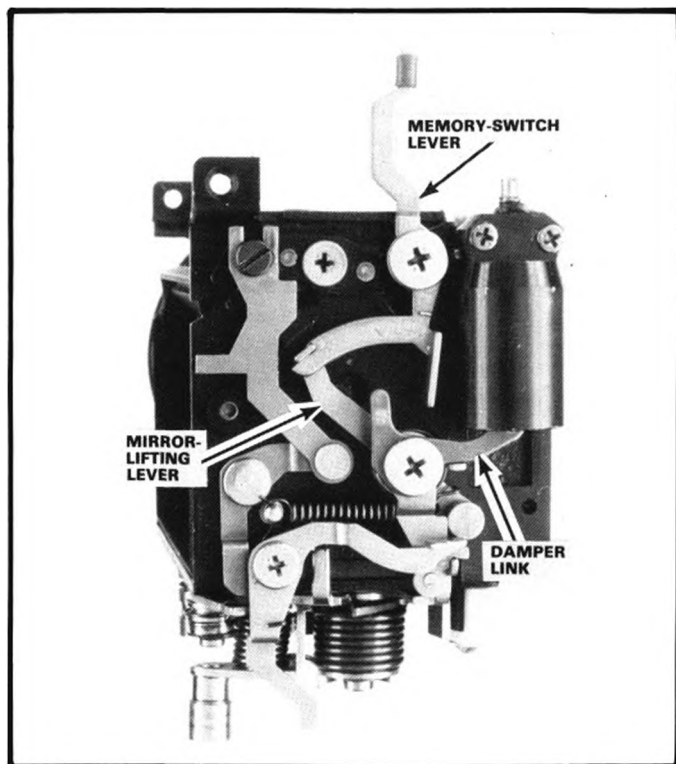

Figure 112

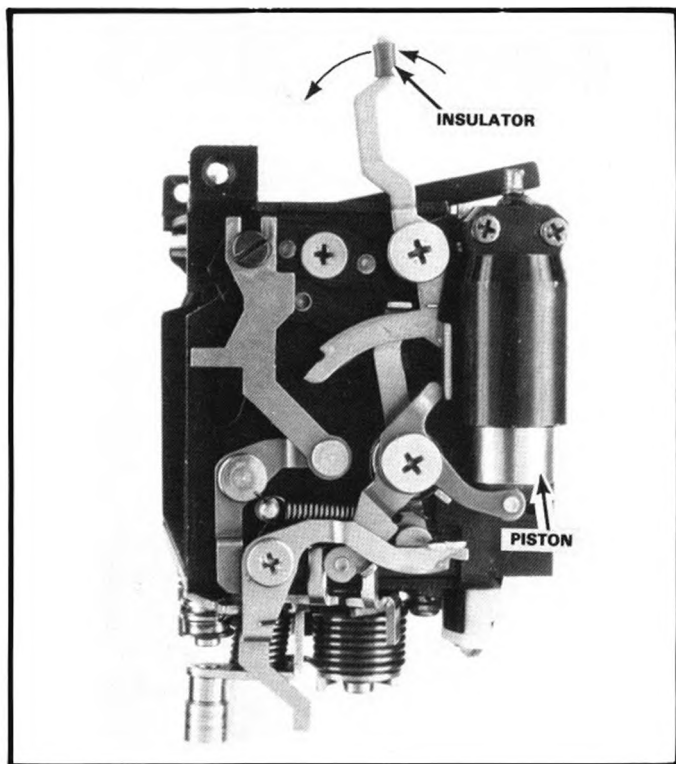

Figure 113

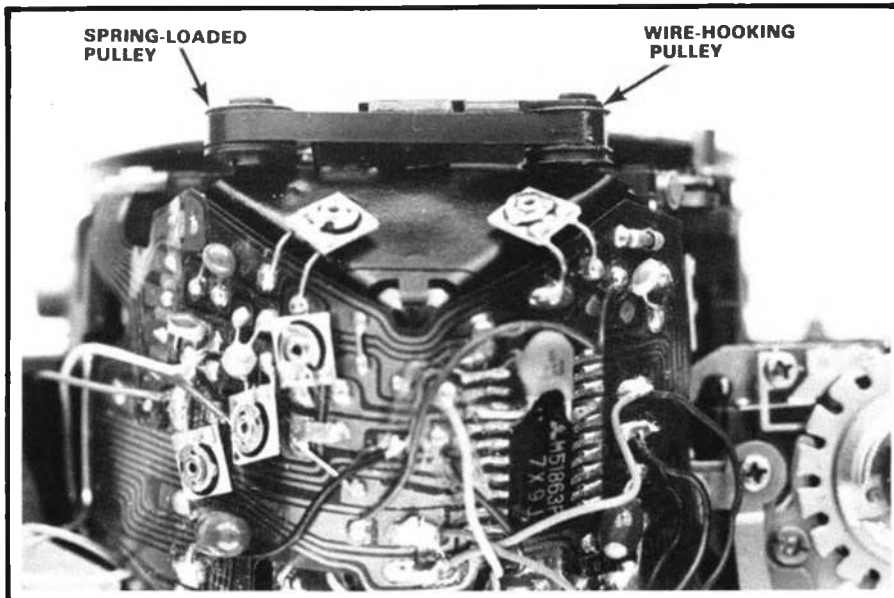

Figure 114

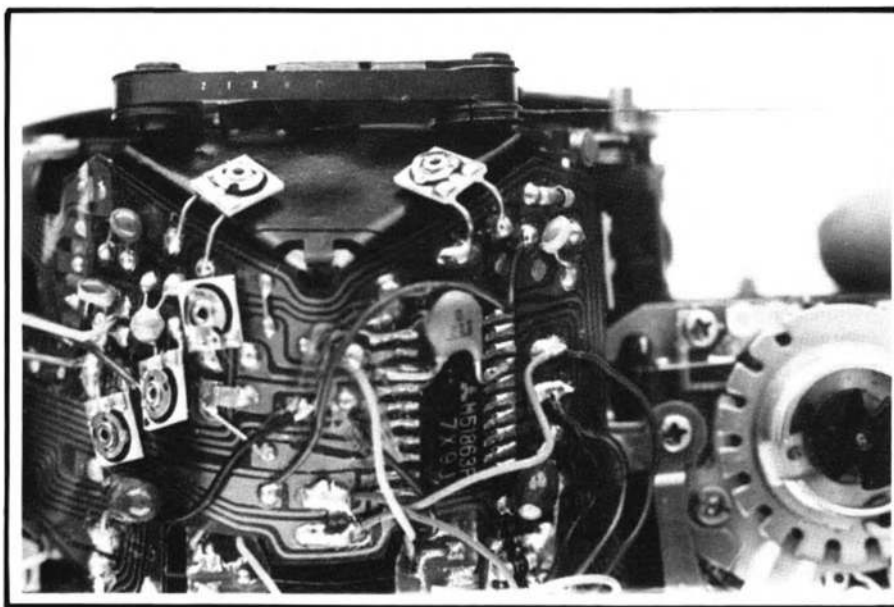

Figure 115

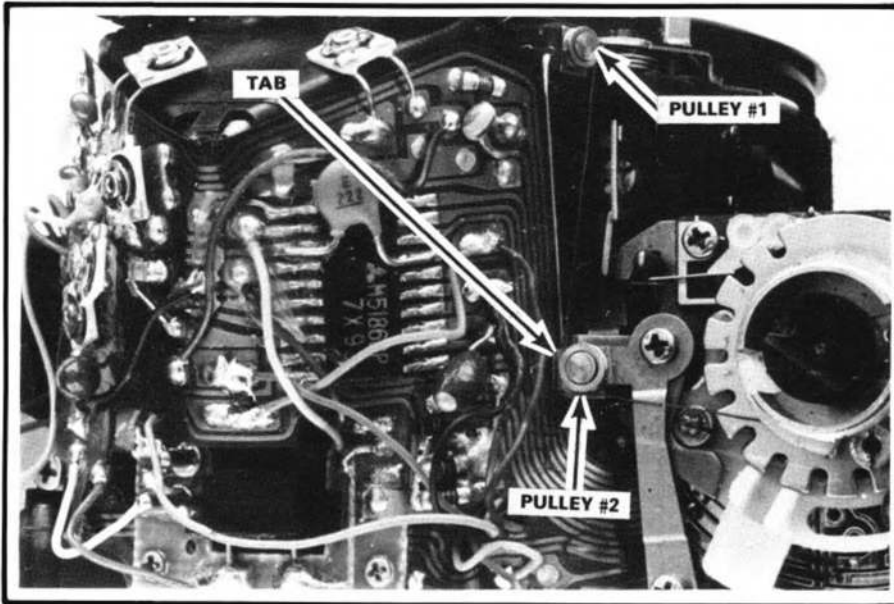

Figure 116

case, its insulator opens the memory switch. Also, the latching end of the memory-switch lever disengages the mirror-lifting lever, Fig. 112. The mirror-lifting lever then drives the mirror to the raised position.

When the mirror nears the taking position, the shutter-release lever, Fig. 106, moves down to release the shutter. The shutter-release lever has a sliding adjustment; after loosening the two screws, you can slide the shutter-release lever up or down. If you move down the shutter-release lever, the mirror doesn't have to rise as far before releasing the shutter. Moving up the shutter-release lever means that the mirror must rise further to release the shutter.

You can check the adjustment after you replace the shutter. Hold down the mirror as you depress the release button at a mechanical setting. Then allow the mirror to move up slowly. The shutter should release when the mirror moves 2/3 of the way to the taking position.

Fig. 106 points out one other adjustment — the self-timer eccentric. You can use the eccentric if the self timer fails to pull down the release slide far enough to release the shutter.

TIMING THE SPEED SELECTOR

On reassembly, it's possible to replace the speed selector 180° out of time. Two tabs on the underside of the speed selector key to two slots in the top of the speed-control cam, Fig. 105.

Start by turning the speed-control cam to a mechanical-speed position. You can tell when you're at one of the mechanical speeds by noting the position of the release-slide latch. When the release-slide latch moves away from the release slide, the mechanical speed-control cam is at either bulb or 1/100 second.

Then seat the speed selector with its detent notches positioned as shown in Fig. 103. The speed selector drops into place when its two tabs pass into the two slots in the speed-control cam.

RECONNECTING THE TUNGSTEN WIRE

Assemble the front-plate/mirror-cage assembly to the camera body before you reconnect the tungsten wire. Then set the speed selector to the 0 position — fully clockwise.

With the tungsten wire disconnected, there's very little tension on the spring-loaded pulley, Fig. 114. But the spring tension increases as the scale wraps onto the wire-hooking pulley. Be careful, then, that you don't accidentally release the wire-hooking pulley with any amount of

spring tension on the spring-hooking pulley. Too much tension could break the scale.

You can get just the shutter-speed scale as a replacement part. Alternately, you can replace the complete shutter-speed indicator assembly; the assembly includes the scale and the pulleys with the spring already tensioned. There's an advantage in replacing the complete assembly — if you replace just the scale, you may encounter tracking and alignment problems. That is, when you get the "0" calibration centered in its window, you may find that the "1000" calibration does not center. However, if the scale breaks, you can normally make a satisfactory repair without replacing parts.

The break usually occurs at the point where the scale cements to the wire-hooking pulley. Part of the scale then remains cemented in place. Simply butt the loose end against the end still attached to the pulley. Then cement the loose end with super glue.

Now slip the knot in one end of the tungsten wire through the slot in the wire-hooking pulley, Fig. 114. Wrap the tungsten wire 2-1/2 turns around the wire-hooking pulley in a clockwise direction (as seen from the back). It's a little tough to wrap the free end of the tungsten wire around the wire-hooking pulley — you don't have a lot of room. But there's another technique you may find to be easier. Before you connect the tungsten wire, rotate the wire-hooking pulley fully clockwise (as seen from the back). The scale then wraps around the wire-hooking pulley, adding tension to the spring.

Next, while holding the wire-hooking pulley to maintain the spring tension, connect the tungsten wire. You may have to allow the wire-hooking pulley to rotate slightly counterclockwise until you can reach the slot. If you need both hands to connect the tungsten wire, you might use a piece of masking tape to hold the spring-loaded pulley in place. Here, it's critical that you don't accidentally release the pulleys. With so much tension on the spring, the scale would definitely break.

After you connect one end of the tungsten wire, hold the other end as shown in Fig. 115. Now let go of the spring-loaded pulley and allow the spring to slowly draw the scale from right to left. The tungsten wire should wrap itself two turns around the wire-hooking pulley. You need then wrap on only 1/2 additional turn.

You may wish to put a piece of masking tape over the wire-hooking pulley to keep the tungsten wire in place. Then route the tungsten wire under pulley #2,

Fig. 116. Notice in Fig. 116 that we've temporarily repositioned the flex circuit to clear pulley #2. Normally the flex covers part of the pulley, Fig. 117.

With the flex repositioned, you can more easily route the tungsten wire between the pulley and the tab, Fig. 116. Finally, wrap the tungsten wire in a clockwise direction around the adjustment collar, Fig. 117. Push the knotted end through the top of the hole in the adjustment collar and seat the tungsten wire within the screwdriver slot.

Only one step remains — adjusting the position of the speed-indicator scale. As you look through the finder, rotate the adjustment collar in a clockwise direction. The clockwise rotating draws the scale from left to right, Fig. 117. Continue turning the adjustment collar until the "0" calibration aligns in the viewfinder window.

TRANSPORT REPAIRS

There's one common repair in the transport — replacing the take-up spool. You may find that the gray section at the bottom of the take-up spool has broken loose. Or, more frequently, the owner has broken off all four of the film-hooking lugs.

The owner breaks the lugs by attempting to squeeze on extra frames at the end of the roll. By forcing the wind lever, he breaks off the lug which hooks the film. He then uses another of the four lugs. When none of the lugs remains, he brings in the camera for repair.

To replace the take-up spool, you must remove the wind seat, Fig. 118. The springs connected to the advance-indicator lever, Fig. 118, then come disconnected. You can remove the wind seat and the counter dial as one unit.

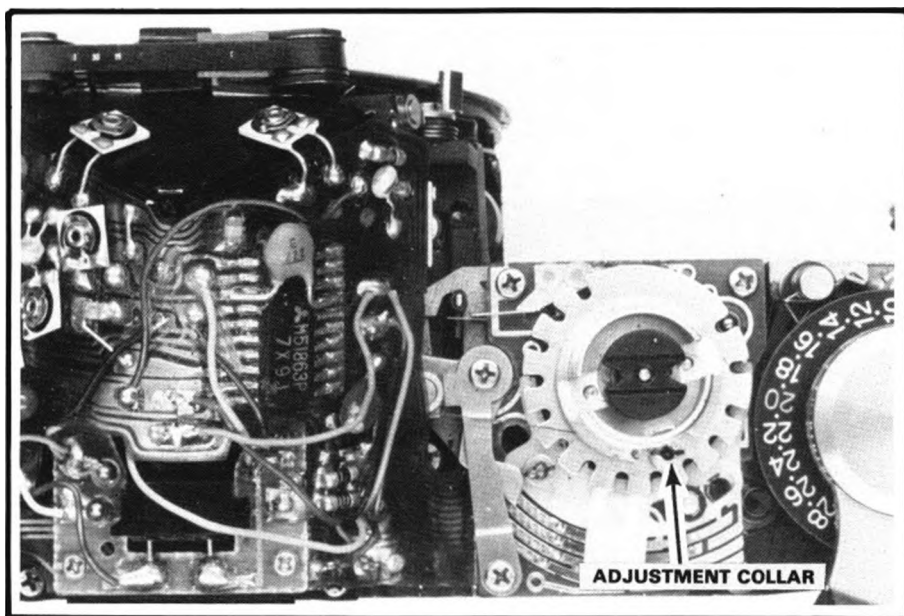

Figure 117

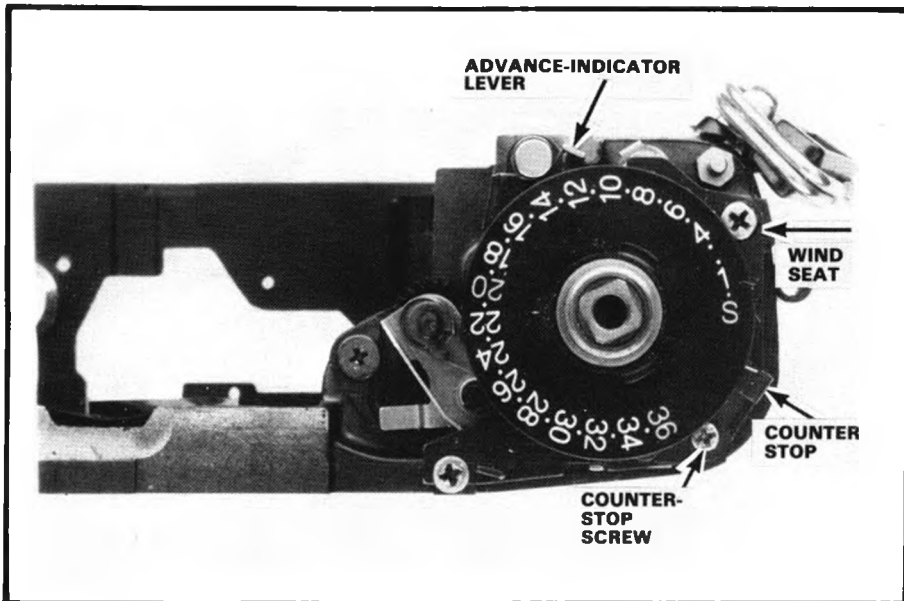

Figure 118

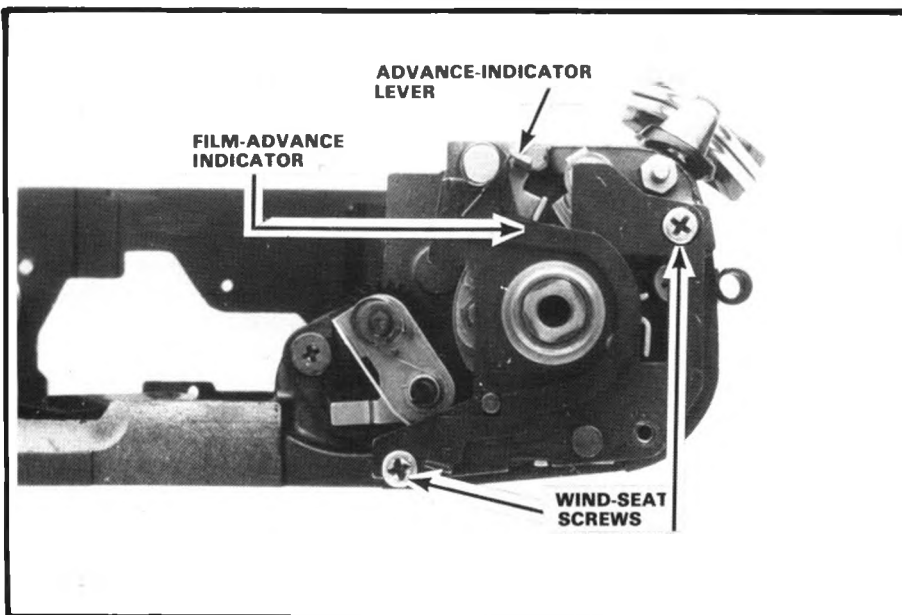

Figure 119

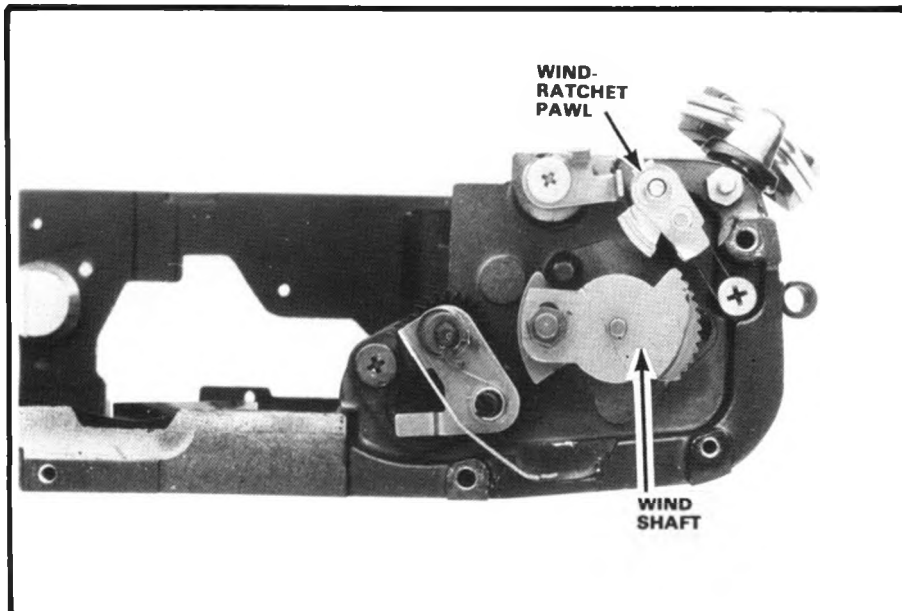

Figure 120

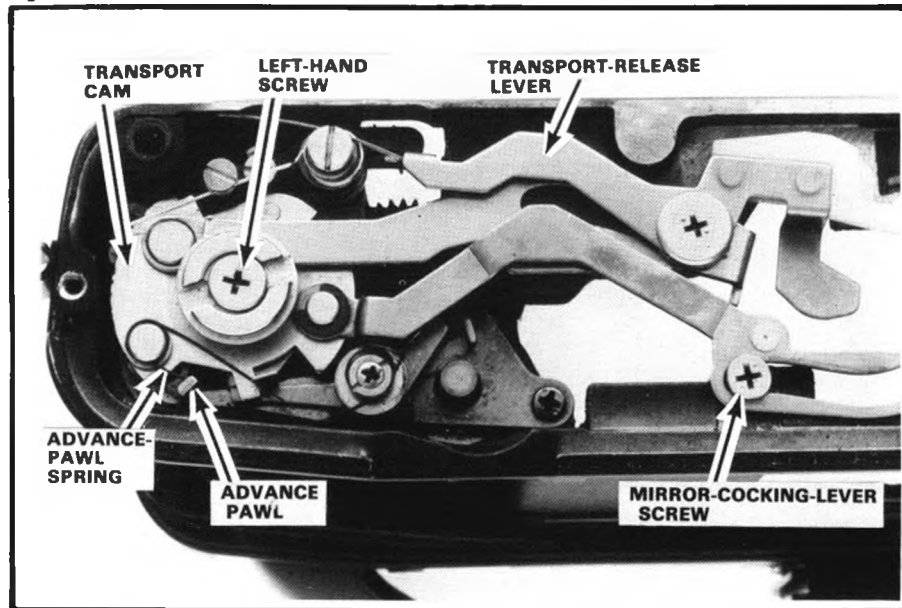

Figure 121

However, you'll find it easier to reconnect the springs if you first remove the counter dial.

Take out the screw holding the counter stop, Fig. 118. The counter stop serves both to connect the counter-dial spring and to stop the counter dial at the "S" position. Lift out the counter dial and the counter stop as one-assembly.

Fig. 119 shows the top of the wind seat with the counter dial removed. Note the two springs which connect to the tab on the advance-indicator lever. The larger spring rotates the advance-indicator lever in a clockwise direction. But, as the film winds onto the take-up spool, it pushes against the sensing lever inside the take-up-spool cavity. The sensing lever attaches to the advance-indicator lever. So, as the sensing lever moves toward the front of the camera, the advance-indicator lever rotates in a counterclockwise direction.

The smaller of the two springs, Fig. 119, now pulls the film-advance indicator counterclockwise. One end of the smaller spring connects to the tab on the advance-indicator lever; the other end hooks to the side of the film-advance indicator.

Both springs remain with the wind seat. Take out the two wind-seat screws, Fig. 119. Then lift out the wind seat. Watch for a loose endplay spacer on the top of the wind shaft, Fig. 120; not all cameras use the endplay spacer. Also, if you removed the wind lever, the wind cam passing through the wind-seat bushing will be loose.

Next lift out the wind-ratchet pawl, Fig. 120. The post on the underside of the wind-ratchet pawl fits between the two ends of the pawl spring. Then, from the bottom of the body, disconnect and remove the two springs that hook to the tab of the transport-release lever, Fig. 121. The upper spring provides the tension which moves the transport-release lever toward the front of the camera; the gold spring serves both as the power-winder switch and as the spring for the transport latch.

Remove the transport-release lever by taking out its screw, Fig. 121. Watch for the loose bushing under the transport-release lever. The shoulder of the bushing goes down, passing through the slot in the mirror-cocking lever.

Also take out the screw holding the shutter-cocking lever and the left-hand screw holding the transport cam, Fig. 121. Before you lift out the transport cam, note the position of the advance-pawl spring, Fig. 121. The short end of the spring connects to a tab on the advance pawl; the long end connects to a tab on

the lock plate, a part under the transport cam. Just to be safe, you might disconnect and remove the advance-pawl spring.

Now lift out the transport cam together with the mirror-cocking lever and the shutter-cocking lever. Fig. 122 points out the lock plate mentioned earlier. The downward-projecting tab on the lock plate comes against the end of the wind latch.

Lift out the lock plate. Then, from the top of the body casting, lift the wind shaft high enough to disconnect the end of the wind-shaft spring. As you lift out the wind shaft, watch for the loose bushing that fits into the top end of the take-up spool, Fig. 123. The bushing normally stays with the wind shaft as shown.

To remove the take-up-spool assembly, Fig. 123, you must first take out the winding-base plate, Fig. 122. Remove the two screws. Then lift out the winding-base plate, the assembly that contains the two wind gears and the latches.

The take-up-spool gear may stay on the underside of the winding-base plate. Or it may stay in the bottom of the body casting. Two tabs on the underside of the take-up-spool gear engage the slots in the take-up-spool shaft. Lift out both the take-up-spool gear and the sprocket gear at the bottom of the body casting. Watch for a washer on top of the sprocket gear.

You can now remove the take-up spool from the back of the body casting, Fig. 123. The take-up spool has three sections — the center shaft which includes the slip spring, the plastic spool (the section that breaks), and the bearing which sits shoulder up on top of the plastic spool. When you order a replacement, you'll get both the plastic spool and the center shaft.

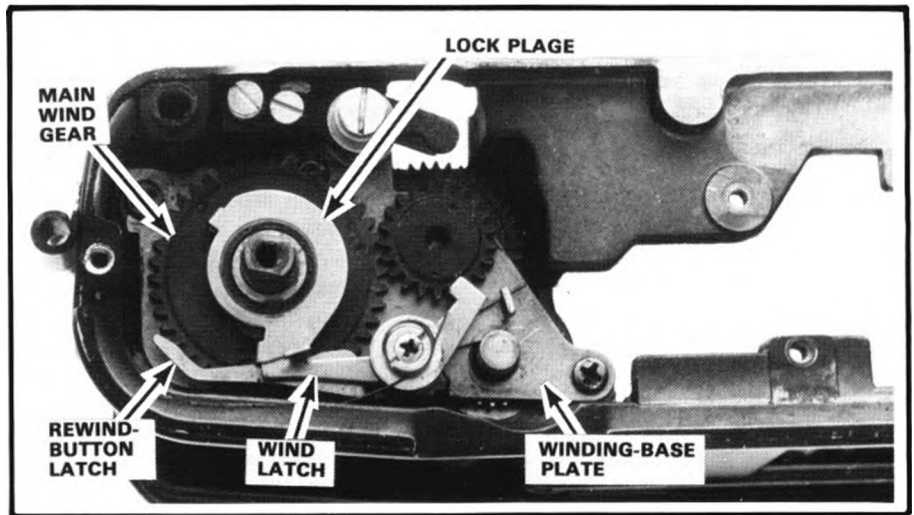

Figure 122

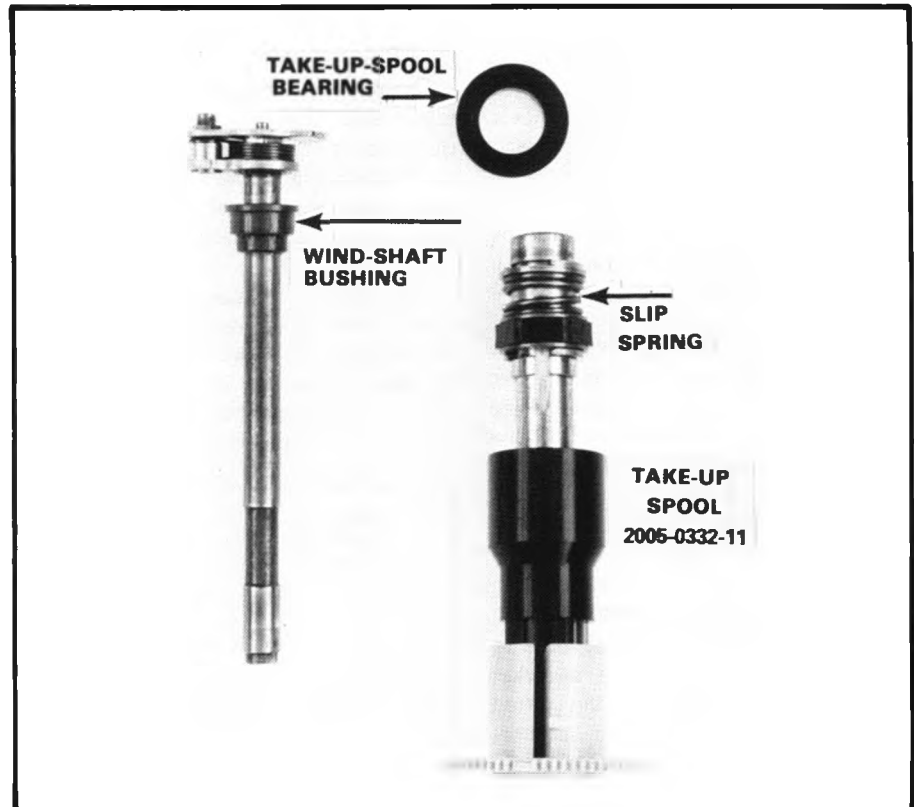

Figure 123

REMOVING THE SPROCKET

To take out the sprocket, first remove the counter-advance assembly, Fig. 124; the base plate of the assembly also serves as the upper bearing for the sprocket. Removing the counter-advance assembly loses the timing of the counter actuator, the black rod running through the bushing of the back-sensing lever.

The camera back pushes the back-sensing lever counterclockwise. As a result, the back-sensing lever brings the counter actuator against the gear on the underside of the counter dial. As the sprocket rotates, it turns the counter actuator. Then, when the notch in the counter actuator comes against a counter-dial tooth, the counter dial advances one film-frame calibration.

Since the sprocket drives the counter

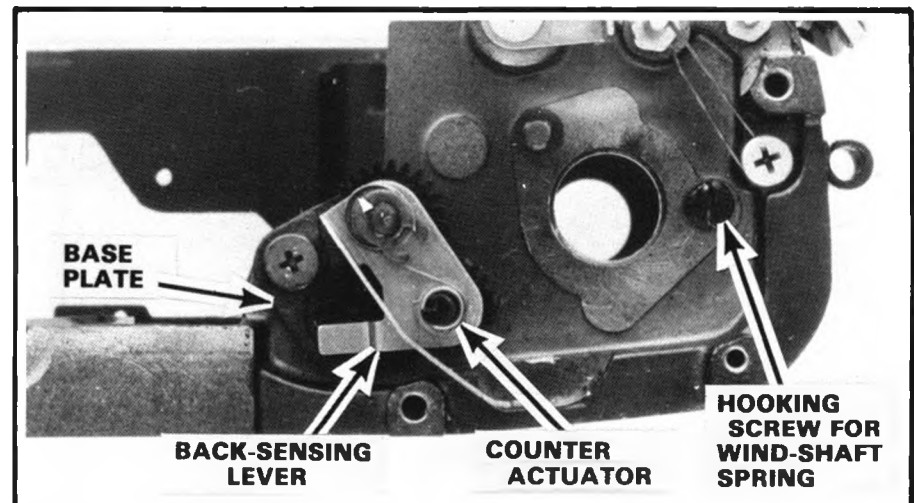

Figure 124

dial, you always get an accurate indication — even though you may shoot double exposures. The double-exposure feature in the XD-11 just disengages the advance pawl, Fig. 121, from the main wind gear, Fig. 122, when you push down the rewind button. Pushing down the rewind button moves the long end of the rewind-button latch, Fig. 122, against the advance pawl.

The timing we mentioned refers to the position of the notch in the counter actuator, Fig. 124. We'll describe the proper timing during reassembly. Although you can remove the counter-advance assembly as a unit, it's easier to retime the counter actuator if you remove the back-sensing lever, Fig. 124. Disconnect and remove the spring on top of the back-sensing lever; notice that the short end of the spring connects to the snap ring which holds the back-sensing lever in place. Now remove the snap ring and the spring. Lift out the back-sensing lever together with the counter actuator.

Also lift out the two plastic gears on top of the base plate, Fig. 124. The smaller gear has a slot which fits over the flat sides of the sprocket rod. Remove the base plate by taking out the cross-point screw.

Three parts inside the sprocket are now loose — the compression spring and two brass washers. You can remove these parts more easily after you take out the sprocket. Remove the screw holding the lower sprocket bearing at the bottom of the body casting. Then lift out the sprocket from the back of the camera.

REPLACING THE SPROCKET

One end of the sprocket has slots to receive the pin through the sprocket shaft. Seat the sprocket with the slotted end down. Then replace the sprocket shaft and the lower sprocket bearing.

Now, from the top of the body, place one of the brass washers over the top of the sprocket rod. Seat the compression

spring next. Finally, place the second brass washer on top of the compression spring.

Replace the base plate, Fig. 124. You'll notice that the base plate has a sliding adjustment; by loosening the cross-point screw, you can shift the base plate in position. The sliding adjustment permits you to adjust the engagement of the counter actuator with the counter-dial gear. You can make the adjustment after you replace the counter dial.

Now, as you replace the back-sensing lever, you can time the counter actuator. Fig. 125 shows the proper position of the notch. Seat the two plastic gears on the base plate. Then insert the counter actuator into the hole in the back-sensing lever. Rotate the counter actuator to the position shown in Fig. 125 and mount the back-sensing lever on the base plate.

Check the position of the counter actuator before you replace the snap ring. If the notch isn't in the proper position, lift the back-sensing lever high enough to disengage the counter actuator. Then turn the counter actuator to the position shown in Fig. 125.

Then replace the spring for the back-sensing lever. Also replace the snap ring and connect the short end of the spring as shown in Fig. 124. Check the assembly by rotating the sprocket; the counter actuator should turn freely.

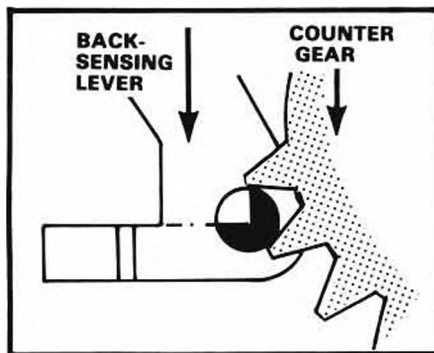

Figure 125

SPROCKET TIMING

Proper sprocket timing assures that the spaces between film frames also fall between perforation holes. Most customers would never notice an error in the sprocket timing. However, some types of slide mounts depend on proper film registration; pins on the slide mounts fit through the perforation holes to hold the film.

To check the sprocket timing before disassembly, just rotate the sprocket toward the rewind side to take up the backlash. The sprocket teeth should then be positioned as shown in Fig. 126. Or, if you're not sure of the proper sprocket position, load a roll of test film. Then hold open the shutter on bulb. Using a pencil, trace around the edge of the focal-plane aperture to draw the frame position on the film. You now have a picture of the frame position on your test roll. The film drawing in Fig. 126 shows where the frame should be in relation to the perforation holes.

You can time the sprocket after you remove the winding-base plate. So, before you replace the winding-base plate, rotate the sprocket to the properly timed position, Fig. 126. Remember to take up the backlash by rotating the sprocket toward the rewind side of the camera.

REPLACING AND TIMING THE WINDING-BASE PLATE

There's one precaution as you seat the take-up spool — make sure the sensing lever for the film-advance indicator is against the front of the body casting. The sensing lever must ride between the take-up spool and the front of the camera. Then replace the take-up-spool gear and the sprocket gear at the bottom of the body casting.

Now locate the punch marks on the top surfaces of the main wind gear and the second gear, Fig. 127. Before you seat

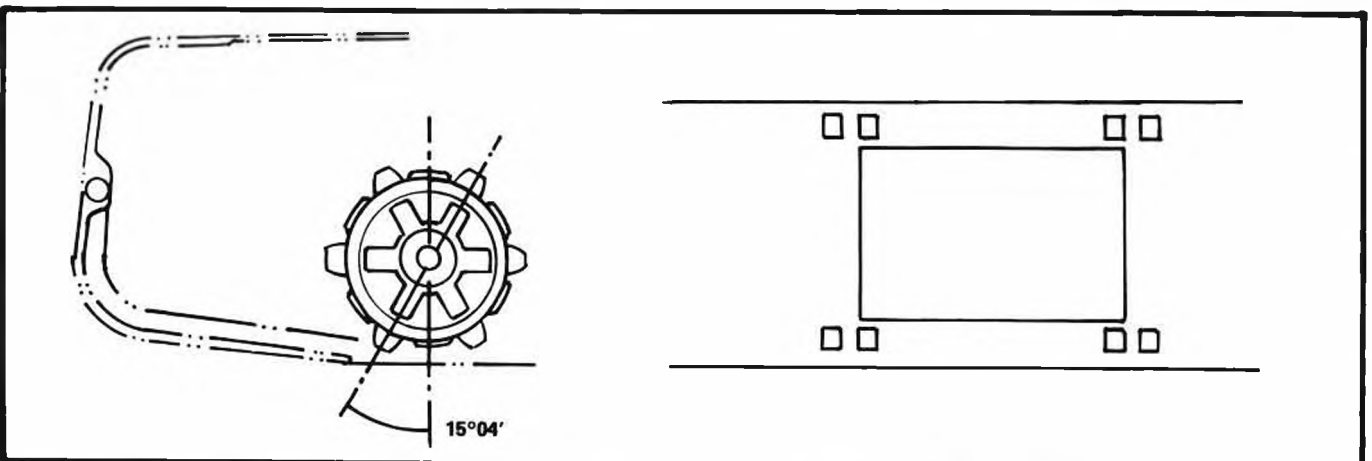

Figure 126 Sprocket position as seen from bottom of camera

Proper film registration

the winding-base plate, rotate the main wind gear until one of its punch marks aligns with the punch mark on the second gear. The wind latch should then be against one of the three lugs on the main wind gear, Fig. 127.

Seat the winding-base plate and recheck the sprocket timing. When you rotate the sprocket toward the rewind end of the camera — thereby bringing the wind-gear lug against the wind latch, Fig. 127 — the sprocket teeth should be positioned as shown in Fig. 126.

After replacing the screws to hold the winding-base plate, seat the wind shaft. You'll have to hold the wind-shaft spring against its tension to connect it to the body-casting screw. Then complete the reassembly at the bottom of the camera — seat the lock plate, Fig. 122, replace the transport cam, and reconnect the springs, Fig. 121.

REPLACING AND ADJUSTING THE COUNTER DIAL

Replace the wind-ratchet pawl and the wind seat. Then reconnect the springs to the advance-indicator lever as shown in Fig. 119.

Now seat the counter dial and the counter stop as one assembly. But, before you replace the screw that holds the counter stop, apply the initial tension to the counter spring. Just rotate the counter dial one turn in a clockwise direction. Swing aside the counter stop and rotate the counter dial to the start position — until the "S" points to the end of the camera, Fig. 118. Then move the counter stop into engagement with the stop tab on the counter gear and replace the counter-stop screw.

The "S" on the counter dial should remain aligned as shown in Fig. 118. If the "S" appears off-center, it won't align with the index on the top cover. You can then adjust the start position by bending the upper lug on the counter stop. To be sure of the proper alignment, you might temporarily replace the top cover. Check to see that the "S" aligns with the top-cover index.

Next replace the camera back and check the operation of the counter actuator. As you close the camera back, the counter actuator should move into the slot between the first and second teeth of the counter gear, Fig. 125. If the counter actuator doesn't align with the tooth slot — and instead comes against one of the gear teeth — you'll see the counter dial shift in position as you close the camera back.

Adjust the alignment of the counter actuator by shifting the base plate of the

counter-advance assembly, Fig. 124. Just loosen the screw and move the base plate until the counter actuator aligns with the first tooth slot.

OTHER TRANSPORT ADJUSTMENTS

If the film fails to transport, suspect the adjustment on the wind latch, Fig. 128. At the end of the cocking cycle, the wind latch should drop into engagement with a lug on the main wind gear. However, if the wind latch fails to engage a lug, the film can turn the sprocket in the reverse direction.

Check the action by using your finger to put reverse pressure on the sprocket as you cock the shutter. You should see the wind latch drop into engagement slightly before the wind-ratchet pawl, Fig. 120, disengages from the teeth of the wind shaft.

You should then find that you can't turn the sprocket in the reverse direction — the wind latch prevents reverse rota-

tion. To adjust the wind latch, loosen the screw and turn the eccentric brass bushing, Fig. 128.

Also note the two eccentrics on the transport latch, Fig. 128. One eccentric controls the position of the release-blocking lever, the lever that prevents you from pushing down the release slide during the cocking stroke. The release-blocking lever sits under the transport latch.

Check the adjustment after partially cocking the shutter. With the transport latch riding against the smooth, outer surface of the transport cam, the release-blocking lever should be over the lower end of the release slide. The release-blocking lever then prevents you from depressing the release button. By turning the eccentric, Fig. 128, you can reposition the release-blocking lever. Turn the eccentric until the release slide appears right in the center of the release-blocking lever with the shutter partially cocked.

The other eccentric on the transport

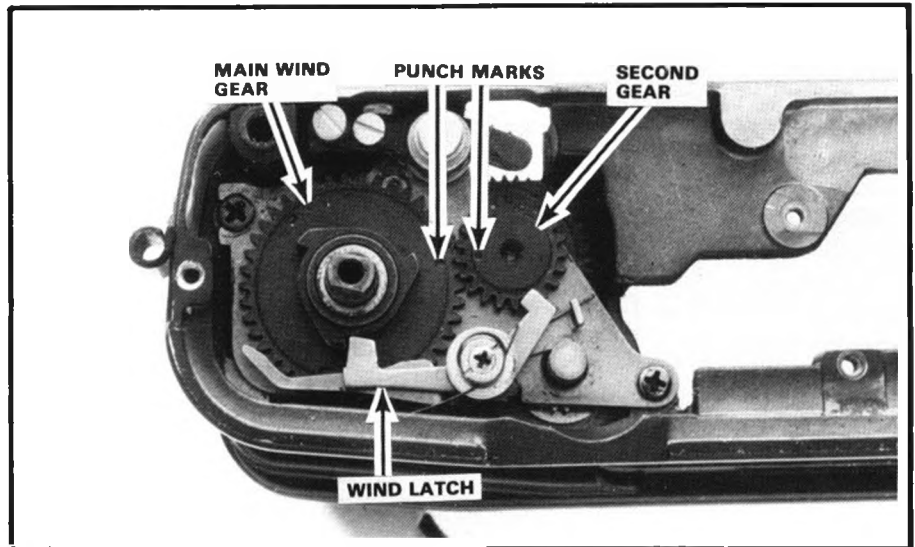

Figure 127

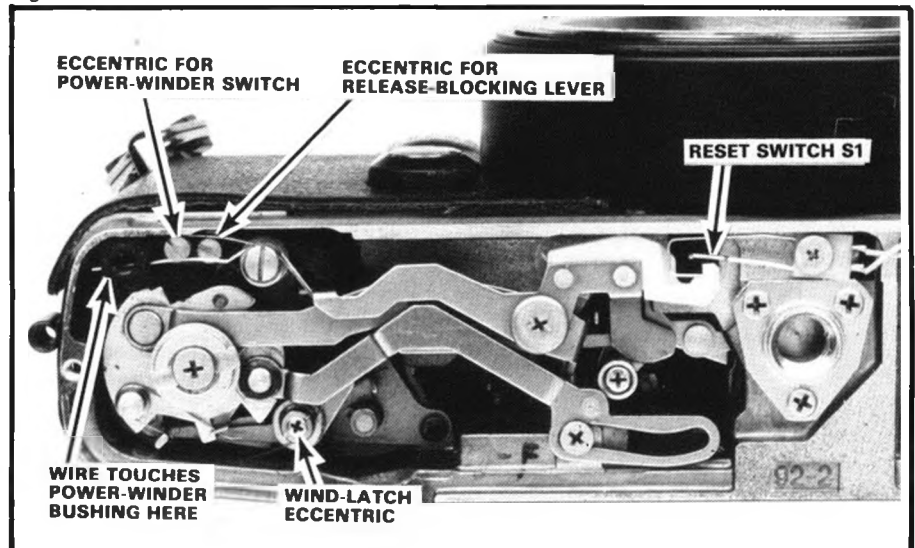

Figure 128

latch controls the position of the power-winder switch. To check the adjustment, again partially cock the shutter. With the transport latch against the outer edge of the transport cam, the gold spring should come against the edge of the power-winder bushing, Fig. 128. Turn the brass eccentric so that it just touches the gold wire.

Now complete the cocking stroke and allow the wind lever to return slowly. When the transport latch drops into engagement with the first step in the transport cam, check the position of the gold wire — the gold wire should completely clear the hole in the power-winder bushing. ■

CONCLUSIONS ON THE XD-11

Some technicians have complained that the modern generation of electronic SLRs can't provide the ruggedness and versatility needed by professional

photographers. Not so the with XD-11. The XD-11 can withstand just about any punishment a pro can dish out. Plus it offers the versatility of every possible operational mode.

As one example of the durability, we recently received an XD-11 which had taken a spill off a motorcycle traveling 80mph. The impact made a mess of the top cover and the rewind knob. Yet the camera still worked!

The versatility comes from the choice between manual operation, automatic shutter speeds, or automatic diaphragm openings. There's also a third mode, one not publicized — fully programmed operation. In the S mode, the XD-11 sets the diaphragm opening and, if necessary, changes the shutter speed automatically. You can then leave the speed knob at the 1/125 setting in the S mode. The XD-11 uses the 1/125 shutter speed if it can. But, if 1/125 won't produce the proper

exposure, the XD-11 selects the shutter speed it needs.

Another of the XD-11's strong points is the shutter. More and more cameras are going to the compact Seiko — the Pentax ME and MV, the Nikon EM, and the Mamiya ZE to name a few. The repair techniques we've described for the XD-11 shutter also apply to the Seikos used in other cameras.

The Seiko makes the camera exceptionally modular as well as durable. Those white, plastic gears in the Seiko aren't nylon — they're Delrin, the toughest of plastics. The Delrin parts never seem to break. Although the Seiko holds up under most types of abuse, there's one mistreatment it can't take — water damage. Water quickly destroys the metal blades.

We've tried to cover the troubleshooting and repair techniques throughout this article. The following chart provides a summary of the troubleshooting:

Summary of troubleshooting:

Symptom	Cause	Symptom	Cause
Blades stick	1. Oil on blades		
Shutter will not release, LEDs o.k.	1. Release magnet M1, Fig. 60, sticking (grease between magnet core and armature).		ground. Check with an ohmmeter between ground and the black wire, Fig. 39; you should measure direct continuity with the shutter cocked, no continuity with the shutter released.
	2. Release switch S3, Fig. 101 — poor contact or out of adjustment.		3. Memory switch, Fig. 33 — poor contact.
	3. Reset switch S1, Fig. 128 — poor contact. S1 should be closed with the shutter cocked.	Camera jams with lens installed (diaphragm fails to reopen)	1. Mirror-tensioning lever, Fig. 108 — sticking.
	4. Ground screw on lower circuit board loose.		
	5. Release magnet M1, capacitor C6, or transistor T6 on lower circuit board. Test by shorting the yellow wire on the lower circuit board to ground; the shutter should release, Fig. 22.	Film will not advance	1. Wind latch out of adjustment, Fig. 128.
	6. IC2. Check the voltage at the yellow wire on the lower circuit board; the voltage should drop from 3V to 0V when you close S3, shutter cocked. The LED base plate, Fig. 104, is not available separately; replace the complete flex.	Overexposure at high light levels and fast manual speeds	2. Take-up spool, lower section, broken loose.
Shutter hangs open on all electronic functions	1. Insulator off lever that opens memory switch, Fig. 33.	No LEDs with release button partially depressed, shutter works ok	1. Oil on interface of shutter electromagnet and armature.
	2. Trigger-switch wire blade or black wire to shutter module shorted to		1. Metering switch S5, Fig. 101 poor contact or out of adjustment. Check by shorting the green wire, Fig. 39, to ground. If the LEDs then turn on, pull the mirror cage and clean the metering switch.
			2. Switch S7, Fig. 61, poor contact. The pin on the M1 armature should

Symptom	Cause	Symptom	Cause
	come against the blade of S7 with the mirror cage tensioned.		3. Trigger switch S4, poor contact.
Shutter does not release, no LEDs	<ol style="list-style-type: none"> 1. No voltage to the lower circuit board. Check for 3V at the red wire, Fig. 21. If you do not get the battery voltage, check the battery compartment and the wiring. 2. H-IC defective. Check for 3V at pin 1 of IC1, Fig. 65, with the release partially depressed. If you do not get the battery voltage, remove the mirror cage, connect a DC power supply, and check for 3V at pin 6 of H-IC with the release partially depressed, Fig. 51. If you get 0V at pin 6, but 3V at pin 5, replace H-IC. 	Overrange LED remains on, diaphragm stops down fully in S mode, shutter delivers only fastest mechanical speed in S and A modes	<ol style="list-style-type: none"> 1. Film-speed resistor SV, poor contact. 2. Mode switch, poor contact.
Underexposure in S mode	<ol style="list-style-type: none"> 1. Diaphragm-control magnet M2, Fig. 62 — oil on interface between core and armature. 	Overrange LED remains on, other functions ok	<ol style="list-style-type: none"> 1. Diaphragm resistor, poor contact. Check for a changing voltage at the AV contact, Fig. 54, as you rotate the diaphragm-metering ring with the release button partially depressed.
Diaphragm always stops down fully in S mode, LEDs ok	<ol style="list-style-type: none"> 1. Diaphragm-control magnet M2, C5, T5, or T13. Test the components as described on page 18, Mar-Apr 1980 issue. 	LED indication does not change in S mode	<ol style="list-style-type: none"> 1. Minimum-aperture resistor, Fig. 59, poor contact. 2. Break in flex strip connecting diaphragm resistor to the flex circuit. Check the MD common voltage at the point shown in Fig. 54 in the S mode. You should measure 1.1 to 2.2V without a lens.
Diaphragm fails to stop down in S mode, other functions ok	<ol style="list-style-type: none"> 1. Diaphragm-control magnet M2, Fig. 62, fails to hold its armature. Check for a dirty interface between the core and armature, and check the adjustment, Fig. 68. 	Shutter hangs open on manual-speed settings, other functions ok	<ol style="list-style-type: none"> 1. Shutter-speed (TV) resistor, poor contact. 2. Shutter-speed-resistor board, shifted in position.
Shutter delivers fastest speed only, other functions ok	<ol style="list-style-type: none"> 1. Electromagnet M3, open coil or not holding its armature. Check by shorting the brown wire, Fig. 39, to ground as you release the shutter. The shutter should stay open for as long as you hold the short. If not, the problem is with the shutter electromagnet M3. 2. Capacitor C9 (between the brown and red magnet leads, Fig. 39) shorted. 3. H-IC defective. Check the voltage at pin 10, Fig. 51. You should get 3V when the shutter releases. 4. IC1 defective. Check the voltage at the brown electromagnet wire, Fig. 39. You should get 0V when the shutter releases. If the brown wire remains at 3V, the IC1 comparator isn't switching low. 	Cannot adjust fast manual speeds	<ol style="list-style-type: none"> 1. Trigger-switch S4, poor contact or adjustment. 2. Constant-current adjustment (Rx7 in Fig. 69) incorrect. Check for 180mv between the points indicated in Fig. 69 — the film-speed resistor must be assembled to get the proper voltage reading.
Auto speeds erratic	<ol style="list-style-type: none"> 1. Air cylinder on side of mirror cage, Fig. 107, dirty, or memory-time-lag adjustment incorrect. 2. Memory switch, poor contact. 		