

# THE CAMERA CRAFTSMAN

MAR - APR 1974

75¢

national  
association of  
service managers



member

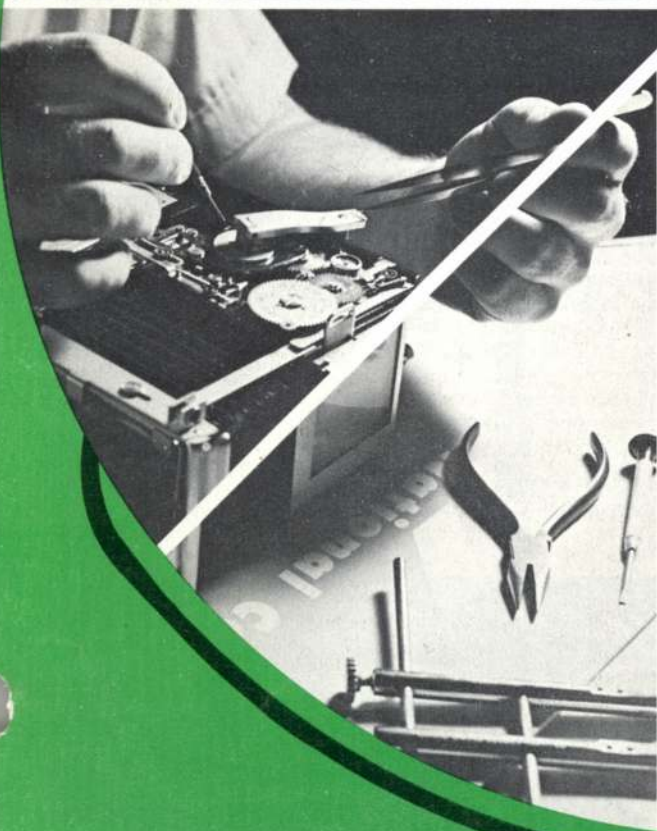
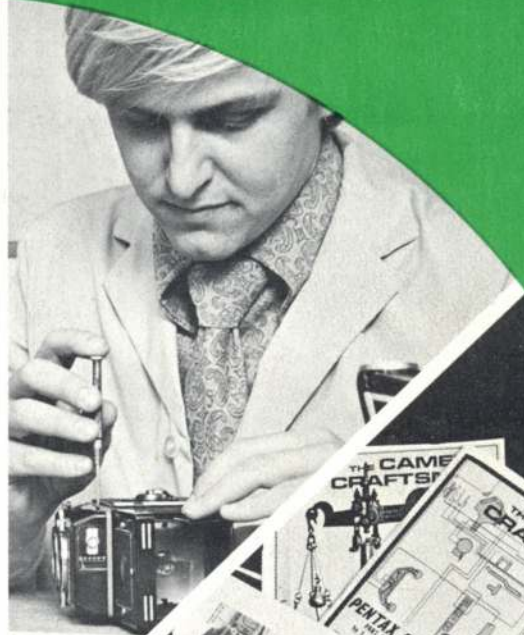

in  
this  
issue

## The Leica M5

by L. C. Lyells

Welcome to  
National Camera  
Area Work



# THE CAMERA CRAFTSMAN

March/April 1974

Volume 20

Number 2

The Periodical of Photo-Technology

## FEATURES

Commentaries	3
The Leica M5, by Lawrence C. Lyells They've done it again.	4
Industry News	12
Lip-Sync Super 8: The Definitive System Reprinted from PMI.	16
Give Your Business a Financial Checkup, by Guy Laird Lesson #3 in managing for better profits.	18

## STAFF

Editor,

Ann McLendon

Technical Director,

Clair H. Schmitt

Contributing Editor,

Lawrence C. Lyells

Art Director,

Ivan Bardon

Publisher,

Samuel L. Love



## DEPARTMENTS

Point to Ponder	2
Practical Optics IV: The Olympus OM-1 50mm f/1.4 lens	15
Help Wanted	10
Data Exchange	31

Published bimonthly. Address all correspondence, manuscripts and advertising to **Camera Craftsman**, 2000 W. Union Ave., Englewood, Colorado 80110. Allow four weeks for change of address — send old address label with change of address notice.

Minimum payment for Data Exchange items: \$5.00, on publication. All material of interest to camera service technicians considered. Address to Data Exchange editor.

Help Wanted ads are placed for employers without charge by National Camera Placement Referral Service. Responses are referred to employers without charge to applicants. Information on employer identity will not be released without written permission. Address correspondence to Placement, **Camera Craftsman**.

Classified advertising rate 75 cents per word. Write for low display rates. All advertising is subject to review and acceptance by the editorial board.

### Subscription Rates

USA:	1 Year \$4.00	3 Years \$11.00
Foreign:	1 Year \$5.00	3 Years \$14.00

## COVER

A formula for success— experience, continual updating, professional pride. See page 3.

Litho in USA

Copyright 1974, National Camera  
Englewood, Colorado 80110

The Camera Craftsman acknowledges with thanks the cooperation of E. Leitz, Inc.

# The

by Lawrence C. Lyells

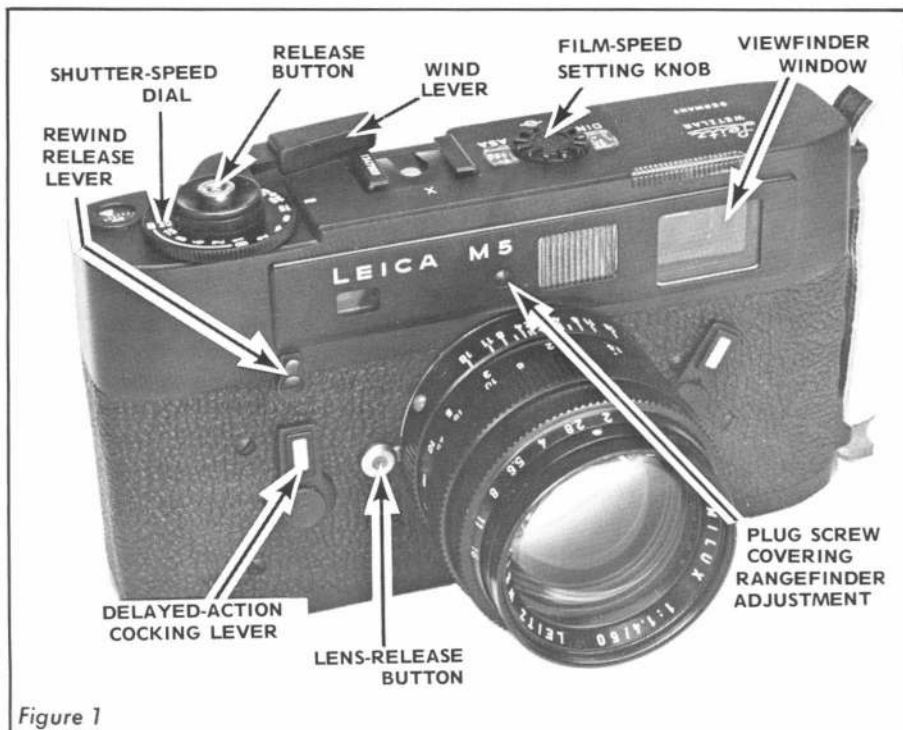

Figure 1

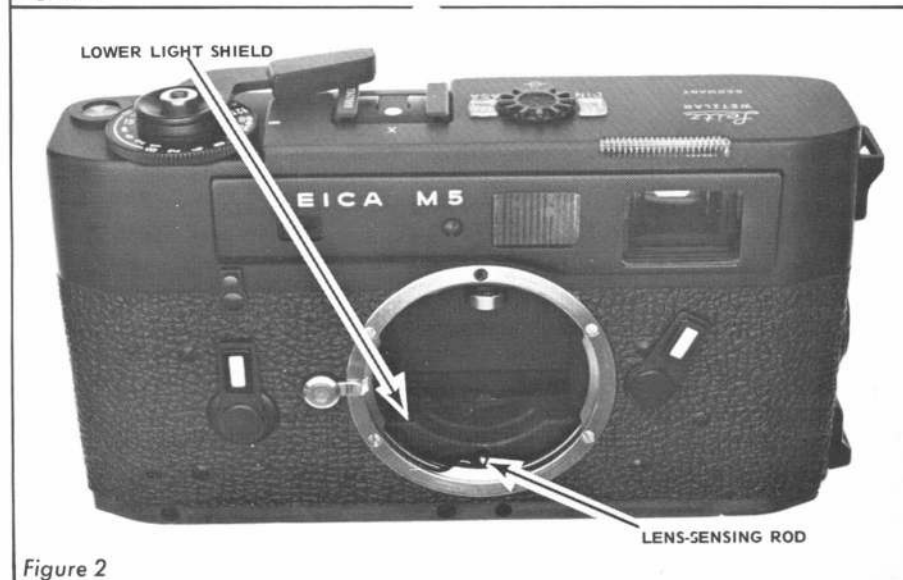

Figure 2

## An All-New Design?

The argument is still going strong — is the M5 really an improvement over the M4?

Even die-hard Leicaphiles seemed to appreciate the subtle refinements in the sleek M4. But the M5, at least from outward appearances, is a new breed — a surprising breakaway from the traditional M-series Leica. Larger, heavier, and higher-priced (\$1,241.65 with the 50mm f/1.4 Summilux lens), the M5 couldn't expect immediate acceptance from conservative M4 devotees.

But the design changes in the M5 have a definite and rewarding purpose. Nearly every change in appearance is the direct result of a single added feature: the through-the-lens metering system.

Leitz's announcement of the first through-the-lens metering system in a rangefinder-type camera came as a genuine press-stopper. By nature, Leitz moves cautiously with design changes; the TTL metering system promised a giant leap into the modern generation of cameras (in some ways, one step beyond). Yet already the M5's metering system has carried over to the Leica CL, tiny offspring of the Leitz-Minolta marriage.

In time, even the Leica purist will probably appreciate the convenience of a built-in cross-coupled exposure meter (and wonder how he ever got by without it). For in designing a TTL meter compatible with a rangefinder-type camera, Leitz came up with a system that approaches the ideal. The CdS cell sits behind the lens, right in the center of the field of view. There's

# Leica M5

no obstruction between the lens and the photocell.

The photocell pops into position during the shutter-cocking cycle; you can hear it "twang" into place at the end of the wind stroke. Simultaneously, an internal switch closes to turn on the exposure meter.

Naturally, the photocell must clear the focal-plane aperture before the shutter releases. So, as you start depressing the release button, the photocell begins ducking out of the way. The photocell completely clears the focal-plane aperture just before the release of the opening curtain.

If you remove the lens, you can see the photocell tucked behind the lower light shield, Fig. 2. But you'll now find that the photocell remains motionless as you cock the shutter. The reason is that the lens couples to the photocell linkage — without the lens, the photocell won't budge.

Installing the lens pushes down the **lens-sensing rod**, Fig. 2. Try holding down the lens-sensing rod as you cock the shutter. You can then watch the photocell jump into place, Fig. 3.

The CdS cell sits a scant 8mm from the shutter curtains. So besides being in the center of the lens field, the CdS cell is mighty close to the actual position of the film. The only time the photocell position becomes less than ideal is when you're using a retrofocus lens that extends too far into the camera body. For example, installing the 21mm wide-angle, Fig. 4, completely erases the advantages of TTL metering — the lens extends so far into the camera that it blocks the photocell arm. You're then forced to use an accessory exposure meter.



Figure 3

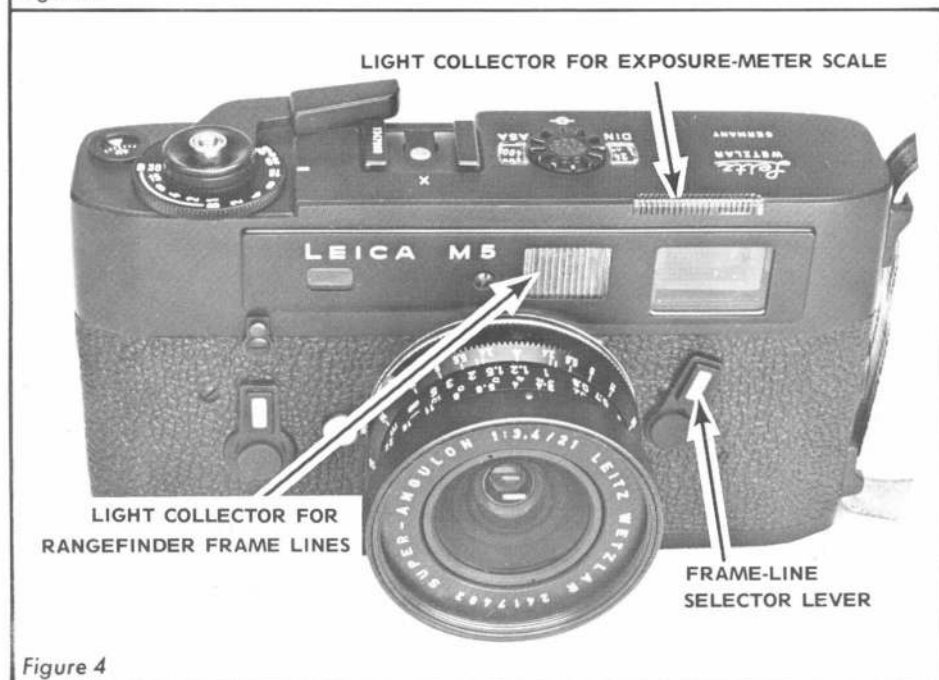

Figure 4

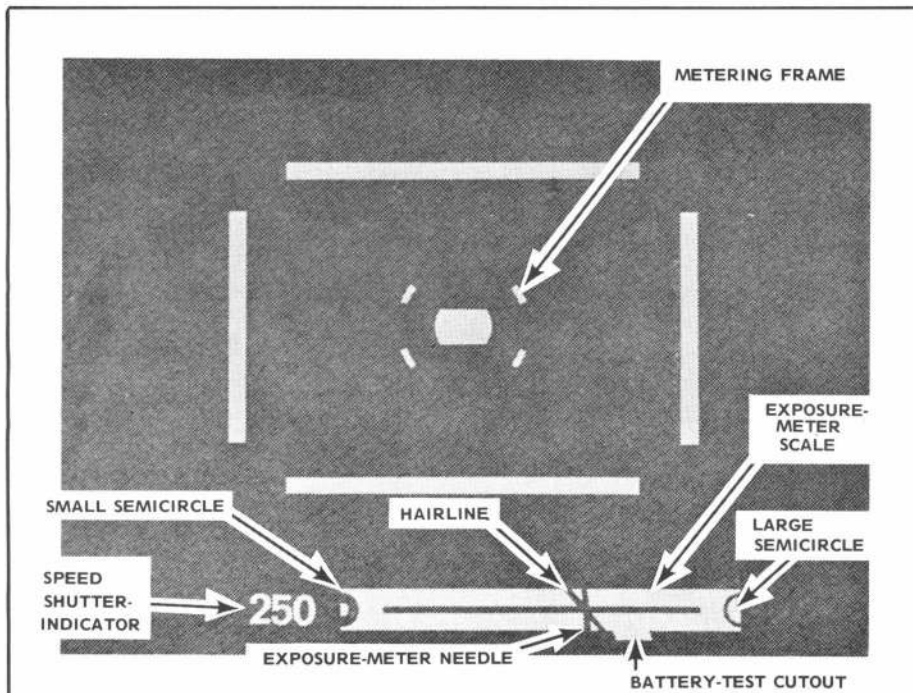

Figure 5

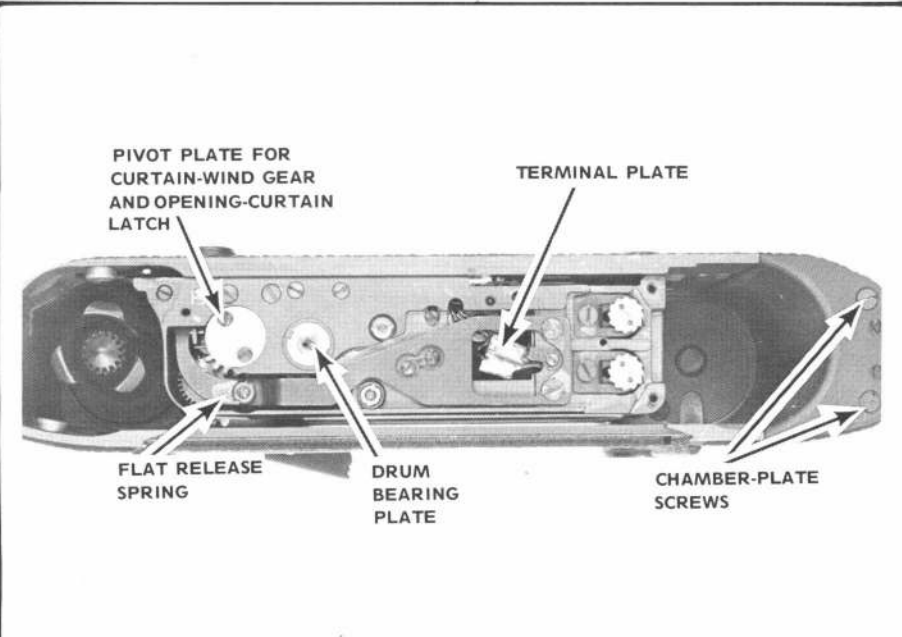

Figure 6

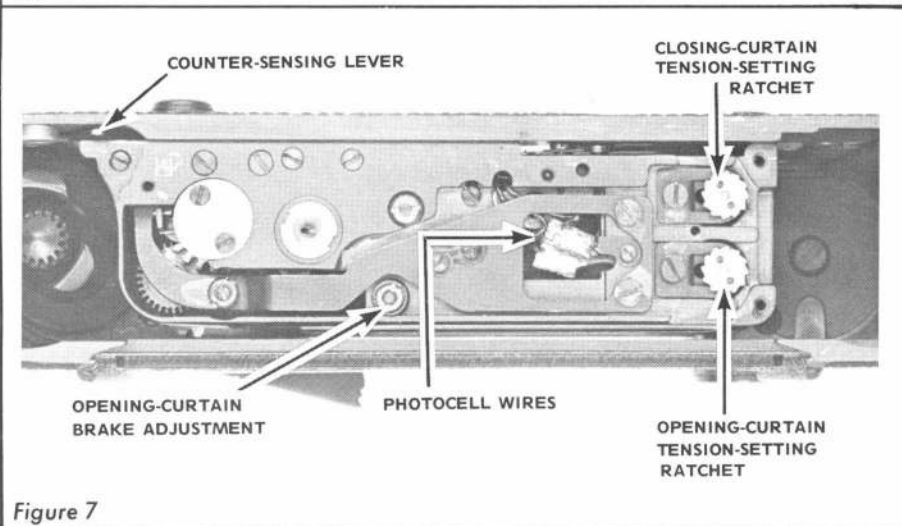

Figure 7

A metering frame visible through the viewfinder shows the actual metering area — 6% of the picture area with the 50mm lens, Fig. 5. The viewfinder also reveals the exposure-meter scale and the shutter-speed setting.

Changing the shutter-speed setting or the film-speed setting moves a reference hairline along the exposure-meter scale. The other diagonal line in Fig. 5 is the exposure-meter needle. You've set the controls for the proper exposure when the two diagonal lines — the needle and the hairline — cross midway.

The two semicircles, one at either end of the exposure-meter scale, provide the f/stop reference. As you change the f/stop, the needle moves along the scale (because more or less light reaches the photocell). If the needle swings toward the smaller semicircle on the left, Fig. 5, you're setting a smaller f/stop — toward the larger semicircle, a larger f/stop.

There's a cutout along the exposure-meter scale that serves as the battery-test reference, Fig. 5. To test the battery, push the frame-line selector lever, Fig. 4, all the way clockwise (as seen from the front of the camera). If the battery is good, the exposure-meter needle moves to the center of the reference cutout.

The battery compartment is at the end of the camera body, underneath the neckstrap (yes, strange though it may seem, both neckstrap lugs are at the same end of the camera). There're no polarity indications for the PX625 mercury cell. But if you install the cell upside down, you won't be able to screw on the battery-compartment cover.

Perhaps the refined exposure-meter system and the startling differences in appearance paint the M5 as an all new design. And that may shake the Leica fancier with his love of tradition. Yet a look beyond the added frills reveals that the M5 is really an M-series Leica at heart. The exceptionally quiet shutter and the bright range-viewfinder clearly reveal their Leica heritage. At the front of the camera, Fig. 4, you can see the familiar vertically striated light-collecting grid for the rangefinder frame lines; the added grid above the viewfinder gathers light for the exposure-meter scale. Lens-release, self-timer, frame-line-selector, and rewind-release controls are unchanged.

Most of the external changes appear at the top of the camera. The speed knob is now a disc located underneath the release button. It's a choice location — since the speed-control disc hangs over the front of the camera, you can conveniently use one finger to set the shutter speed while you're looking through the viewfinder.

All the slow speeds preceded by a "B" (B1 through B30) are actually "bulb" exposures. The number just tells you how long to hold the release button depressed. Mechanically timed speeds range from 1/1000 second through 1/2 second. The dot on the speed-control disc identifies the fastest full-aperture speed for X sync — 1/50 second.

Another relocated control is the rewind knob. The conveniently canted rewind knob of the M4 couldn't carry over to the M5 — the galvanometer needed the room. So instead, the M5's rewind knob is on the bottom of the camera. If a customer brings you an M5 with the complaint that he can't rewind the film, there's a good chance you can blame the bottom rewind. Some foreign film cassettes lack the crosspiece in the bottom of the spool.

### View At The Bottom Of The M5

The M5 retains the load-from-the-bottom technique, a long-standing Leica tradition for loading film. And there's still the familiar drawing on the bottom cover plate that shows the film-threading procedure.

But removing the bottom cover plate does spotlight a few variations that distinguish the M5 from other M-series Leicas. Most obvious is the addition of the **terminal plate**, Fig. 6. Four wires run to the terminal plate — two from the photocell (both black), one from the on/off switch (also black), and one from the switch that provides the battery-test feature (green).

The easily accessible terminal plate provides a handy method for checking the CdS cell. If you suspect a defective CdS cell, just unsolder one of the black photocell wires, Fig. 7. Then, hook an ohmmeter between the disconnected wire and the other photocell wire at the terminal plate. Check to see that the resistance value changes as you vary the f/stop — remember, the shutter must be cocked and the lens must be installed to raise the photocell.

Another variation is in the tension-

setting arrangement for the shutter curtains. In the May-June 1973 **Camera Craftsman**, we described the tension adjustments in the M-series Leicas — the locking collars which hold the take-up rollers. But the M5 uses tension-setting ratchets with locking pawls. To add tension, turn the ratchets in a counterclockwise direction; to let off tension, push down the pawls and turn the ratchets in a clockwise direction.

Leitz doesn't specify the travel times for the shutter curtains. Rather, the factory relies on a torque screwdriver to set the proper amount of tension. So, assuming that our new evaluation camera met factory specifications, we used the National Camera Comparascope to check the travel time — 11 milliseconds with the Travel-Time Mask, 12 milliseconds edge-to-edge.

The design of the counter-return mechanism is another M5 variation. No longer does the counter return as you pull out the take-up spool — rather, it returns as you remove the base plate of the camera.

Locate the lever near the take-up spool chamber in Fig. 7 — that's the **counter-sensing lever**. Installing the base plate pushes in the counter-sensing lever. Now, the counter dial advances as you cock the shutter. When you remove the base plate to

load a new roll of film, the counter-sensing lever frees the counter dial. And the counter dial flips back to its starting position, two calibrations past "0." As you'll see a little later, the counter-sensing lever does present a new complication in replacing the body shell.

### Exposure-Meter Adjustments In The M5

In adding an exposure meter to the M-series Leica, Leitz stuck by its custom of providing easily accessible adjustments. All three variable resistors in the exposure-meter circuit have special clearance holes in the body shell. That means you can reach the adjustments without disassembling the camera.

Removing the plug screw under the neckstrap reveals the battery-test adjustment, Fig. 8. To reach the other two adjustments, take out the lower neckstrap lug — it's held by two screws under a section of leatherette. Lifting off the plate beneath the neckstrap lug exposes the two clearance holes, Fig. 8. (Notice in Fig. 8 that we've also removed the leatherette that conceals the screws of the upper neckstrap lug — removing the upper neckstrap lug is a necessary step in the top-cover disassembly.)



Figure 8

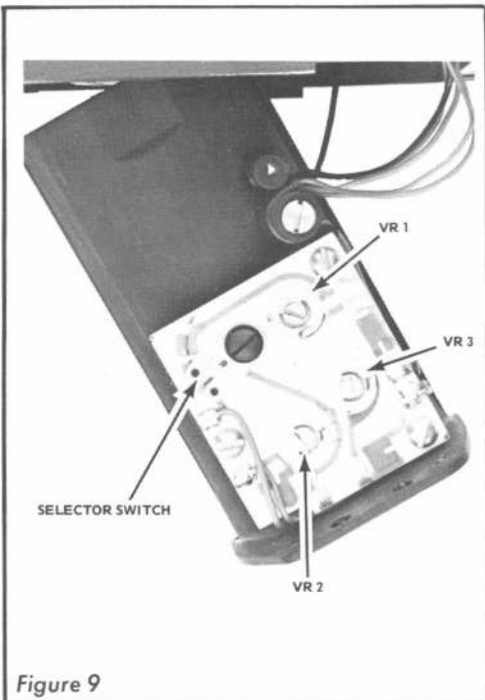

Figure 9



Figure 10

Both VR2 and VR3, Fig. 8, control the accuracy of the exposure-meter readings. VR2 is in series with the galvanometer — that's your total-response adjustment. VR3, in parallel with the galvanometer, is your linearity adjustment.

All three variable resistors, two for accuracy adjustments and one for battery-test, are on a circuit board mounted to the supply-spool chamber plate. To reach the circuit board, take out the two screws at the bottom of the camera, Fig. 6; these screws hold the chamber plate to the body shell. Now, slide the chamber plate toward the bottom of the camera.

Fig. 9 shows the circuit board still mounted to the chamber plate. The **selector switch** at the corner of the circuit board determines whether or not the CdS cell is in the circuit. In Fig. 9, the selector switch is in the "normal" position for exposure-meter readings.

When you select the other position — the battery-test — the selector switch moves to the position shown in Fig. 10. A forked lever connected to the selector switch (on the other side of the circuit board) normally straddles the **switch-control lever** mounted to the inside of the body shell. One end of the switch-control lever comes against the frame-line selector lever. So pushing the frame-line selector lever clockwise swings

the switch-control lever. And the switch-control lever moves the selector switch to the battery-test position, Fig. 10.

In the schematic, Fig. 11, we have shown the selector switch as SW2. The other switch — SW1 — is the on/off switch. Although you can't as yet see SW1, you know that cocking the shutter closes the switch. So battery current flows through the CdS cell to the galvanometer.

Moving the selector switch from position #1 to position #2, Fig. 11, disconnects the CdS cell. Now, the variable resistor VR1 replaces the CdS cell in the exposure-meter circuit.

Since it's so convenient to remove the chamber plate, you can make a quick check for a defective galvanometer. Of course, having a separate battery-test circuit provides a built-in troubleshooting clue. If the galvanometer needle won't deflect in normal operation — but does work during the battery-test — you know that there's nothing wrong with the moving coil.

But suppose that the galvanometer needle doesn't deflect in either position of SW2. You can check the moving coil by hooking your negative ohmmeter lead to the red wire on the circuit board and your positive lead to the blue wire — that hooks the ohmmeter directly across the galvanometer. If the galvanometer needle deflects, the problem is probably in the battery connections.

An exposure meter that works only during the battery-test may have a problem with the on/off switch SW1 or with the photocell. Check for a switch malfunction by hooking your positive ohmmeter lead to the red battery wire and hook the negative ohmmeter lead to the blue wire on the circuit board; and hook the negative ohmmeter lead to the black battery wire. With the shutter released, the galvanometer needle should not deflect. Yet the needle should deflect when you cock the shutter. If it doesn't, the problem is probably in SW1 or its wiring.

Replacing the chamber plate is a little tricky. The forked lever on the circuit-board selector switch must straddle the end of the switch-control lever — and you can't see through the body shell to align the forked lever. So first move the selector switch to the battery-test position, Fig. 10. Then, as you install the chamber plate, hold the frame-line selector lever all the way clockwise.

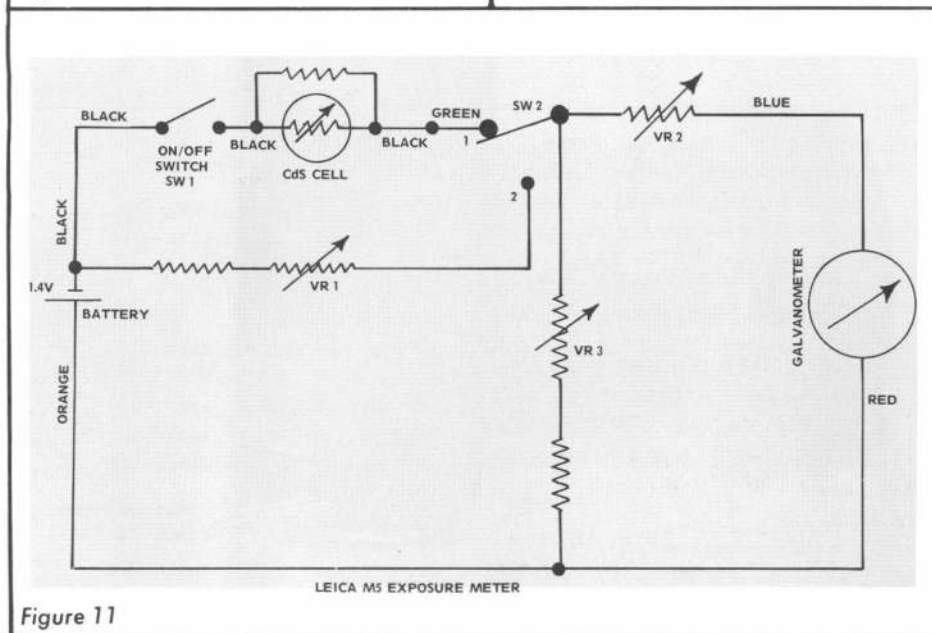

Figure 11

Once you've seated the chamber plate, look through the viewfinder and check the battery-test feature. The needle should move as you actuate the frame-line selector lever. If it does, you know that the forked lever found its way over the switch-control lever.

### Removing The Top Cover Plate

The procedures for removing the top cover plate are very similar to those in other M-series Leicas. That retaining ring above the wind lever is as tight as ever. Fortunately, removing the wind-lever retaining ring is the only irksome step in the disassembly.

The shutter-speed dial and the calibration plate are separate parts. A retaining ring holds the two parts together — the same retaining ring holds the shutter-speed dial to the speed-setting ring inside the camera. Remove the retaining ring and the two sections of the shutter-speed dial. On reassembly, you'll have to align the calibration plate with its index before you tighten the retaining ring.

Two slots on the inner circumference of the shutter-speed dial straddle the two lugs of the **speed-setting ring**, Fig. 12. At the "B30" position ("bulb" — hold the shutter open for 30 seconds), a downward-projecting tab on the shutter-speed dial comes against the adjustable stop on the top cover plate. That is, with the "B30" calibration centered in the viewfinder readout, the adjustable stop should arrest the shutter-speed-dial tab.

On reassembly, just turn the speed-setting ring until "B30" centers in the viewfinder readout. Then, replace the shutter-speed dial with its downward-projecting tab against the adjustable stop. Make sure the two slots in the shutter-speed dial straddle the tabs on the speed-setting ring.

Now, peel off the dust seal, Fig. 12, to reach the two top-cover-plate screws. Also, peel off the two sections of decorative leatherette — the section covering the film-speed-setting-knob screw and the section covering the two screws holding the upper neckstrap lug. Remove the top-cover-plate screws, the upper neckstrap lug, and the film-speed setting knob.

Going to the back of the camera,

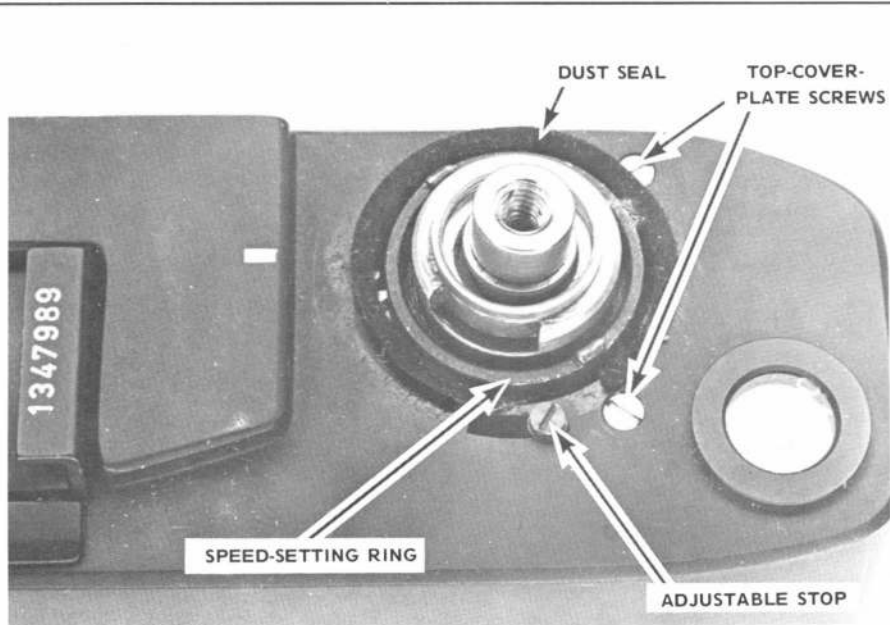

Figure 12

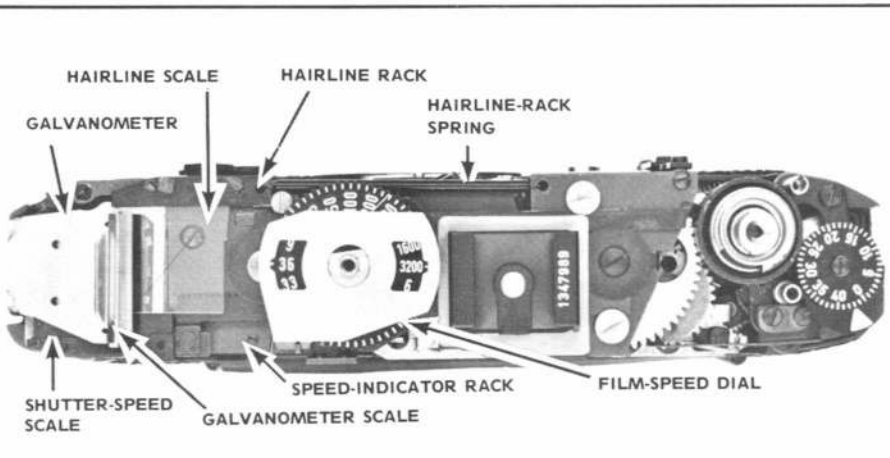

Figure 13

unscrew the two sync terminals (notice that the M5 has dropped Leica's traditional symbols — the flashbulb and the lightning flash; the letters "M" and "X" now indicate the sync delays). And at the front of the camera, remove the upper lens-mounting-ring screw.

As in other M-series Leicas, a black sealing compound covers the black screw at the top of the lens-mounting ring. The sealing compound serves only one purpose — a possible forecast as to the camera's condition. If the sealing compound is disturbed or missing, you know that someone has been into the camera.

Now, while holding in the rangefinder-control lever, slide the top cover plate up and off the camera body.

### Operation Of The Mechanical Linkage System

For a mechanical linkage system, the M5 coupling is remarkably straightforward — not a single cord or chain to reroute on reassembly. Instead, two racks — the **hairline rack** and the **speed-indicator rack** — mount to a plate sitting on top of the rangefinder, Fig. 13.

The hairline rack, toward the front of the camera, carries a transparent scale with a black hairline; this is the hairline you see through the viewfinder, superimposed on the exposure-meter scale. The speed-indicator rack carries the shutter-speed scale. There's a mirror mounted above the galvanometer

(continued page 22)

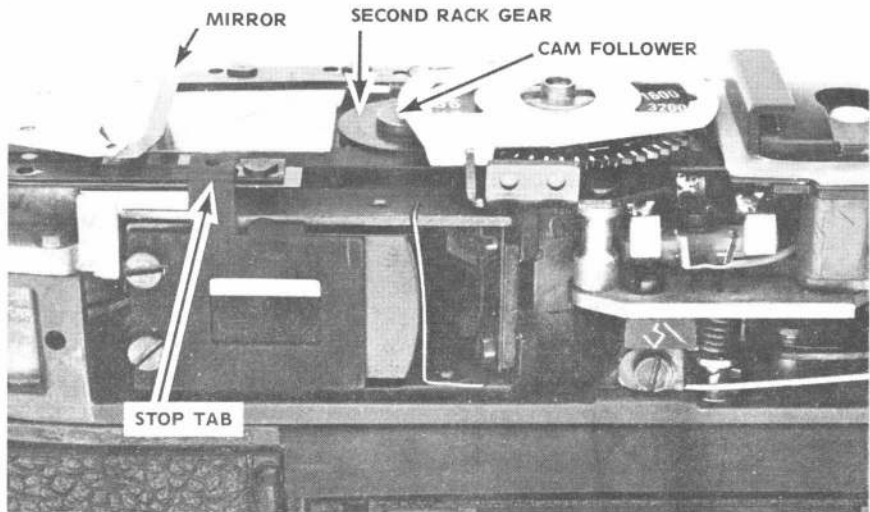

Figure 14

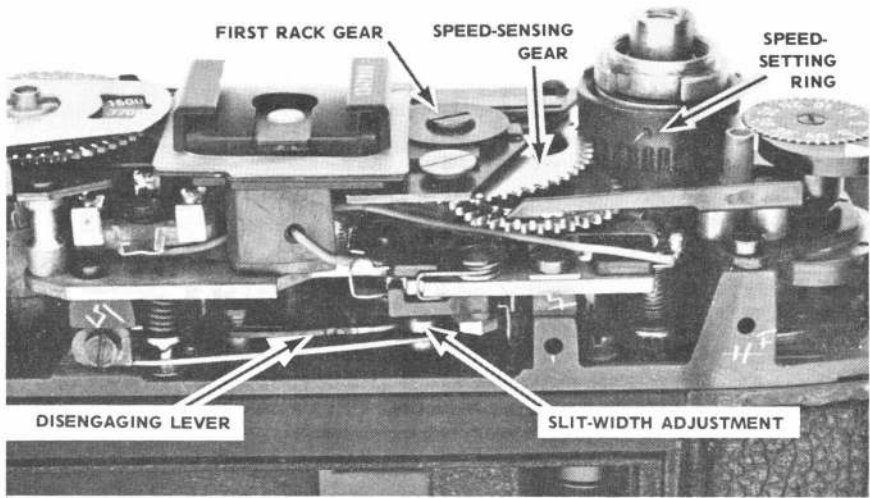

Figure 15

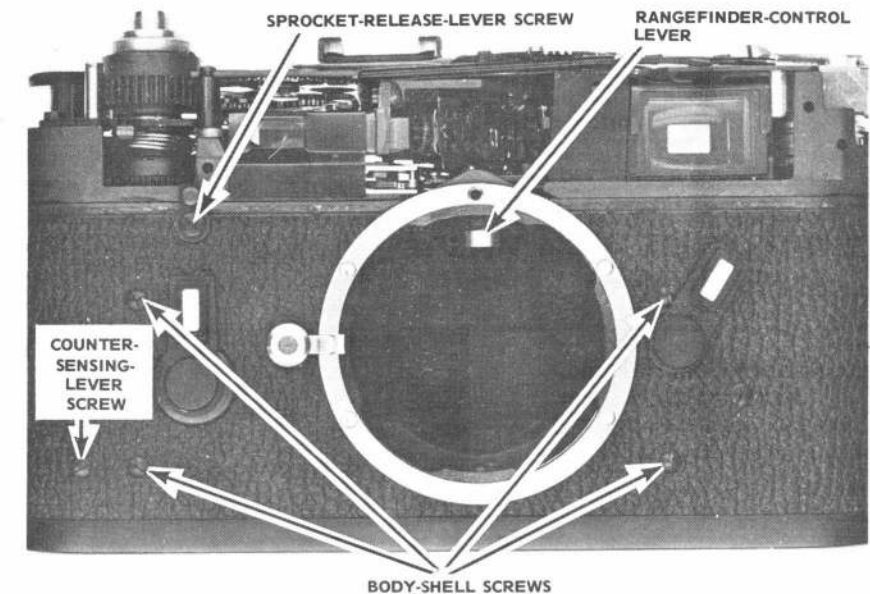

Figure 16

(from page 9)

which reflects the shutter-speed-scale, the hairline, and the galvanometer-needle images into the viewfinder, Fig. 14.

Changing the shutter speed moves both the hairline rack and the speed-indicator rack. A row of teeth on the speed-setting ring turns the **speed-sensing gear**, Fig. 15. And the speed-sensing gear couples directly to the shaft mounting the first **rack gear** (a gear located underneath the metal disc shown in Fig. 15).

So the first rack gear moves the speed-indicator rack. And the shutter-speed scale at the end of the speed-indicator rack relates the speed setting through the viewfinder.

Another row of teeth on the speed-indicator rack engages the second rack gear, Fig. 14. The second rack gear engages both the speed-indicator rack and the hairline rack. Consequently, the movement of the speed-indicator rack simultaneously drives the hairline rack to position the hairline.

Selecting the film speed also positions the hairline rack — but not the speed-indicator rack. The second rack gear floats freely on the linkage plate; only its engagement with the two racks holds it in the camera. So besides its ability to rotate as you change the shutter speed, the second rack gear can slide to the right or to the left in Fig. 14.

The right-or-left travel of the second rack gear positions the hairline rack. Yet the speed-indicator rack, locked in place by its coupling to the speed-setting ring, stays put. As the second rack gear slides in either direction, it merely rolls along the teeth of the speed-indicator rack.

Notice the brass disc on top of the second rack gear, Fig. 14. The brass disc is a cam follower, tracing against a cam on the underside of the film-speed dial. A tension-type spring hooked to the hairline rack holds the cam follower against the film-speed setting cam.

As you set a slower film speed, the film-speed setting cam pushes the second rack gear toward the galvanometer. In turn, the second rack gear drives the hairline rack in the same direction. Setting a faster film speed allows the spring-loaded hairline rack to move away from the galvanometer.

## Removing The Body Shell

There are only a couple of new twists in removing the body shell. For one, the chamber plate containing the circuit board comes out with the shutter assembly. So remove the two screws holding the chamber plate to the body shell, Fig. 6.

Now, cock the delayed-action escapement (self-timer) — that prevents the escapement from running down as you remove the body shell. Take out the rewind-release lever and the five body-shell screws indicated in Fig. 16. Holding in the rangefinder-control lever, slide off the body shell.

The two battery wires from the circuit board remain attached to the battery-compartment terminals. Unsolder the black wire (negative) from the center terminal of the battery compartment. And unsolder the orange wire (positive) from the terminal at the edge of the battery compartment.

There's also a new problem in replacing the body shell. Once you've separated the shutter assembly from the body shell, the **counter-control lever**, Fig. 17, springs away from the end of the camera. The spring on the counter-control lever (actually a part of the lever) must pass to the inside of the body shell.

As you replace the shutter assembly, you'll find that the body shell refuses to seat fully; the counter-control-lever spring blocks the upper end of the body shell. So push in the counter-control-lever spring — toward the shutter assembly — until it passes to the inside of the body shell. The shutter assembly then drops into place.

But there's one more reassembly complication — the tab on the counter-control lever, Fig. 17, must pass through a forked slot in the counter-sensing lever. And the counter-sensing lever remains with the body shell. Consequently, the realignment can be an "in-the-dark" procedure.

We found it convenient to completely remove the counter-sensing lever before installing the body shell. One screw holds the counter-sensing lever. The screw, Fig. 16, threads into a shouldered nut at the inside of the body shell — the counter-sensing lever pivots around the shoulder of the nut.

Once the body shell is in place, you can work through the take-up-spool chamber to install the counter-sensing

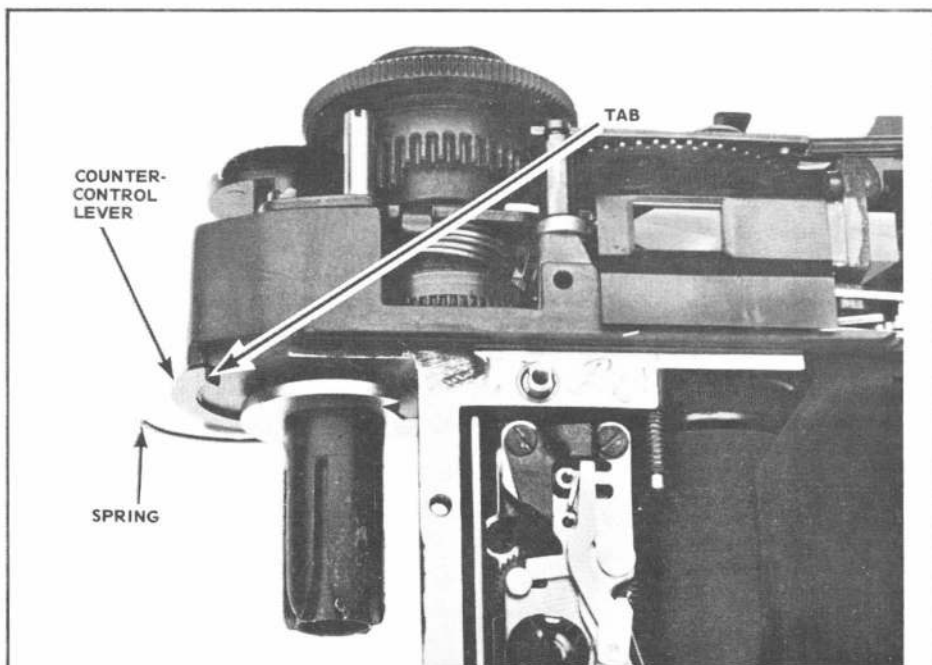

Figure 17

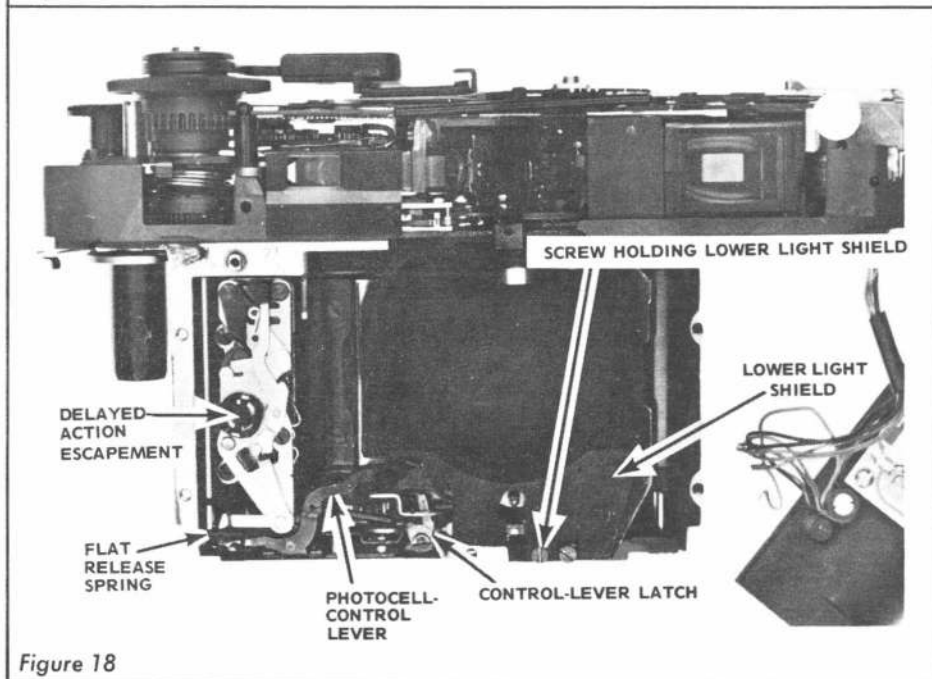

Figure 18

lever. This way, you can see that the fork at the end of the counter-sensing lever straddles the tab on the counter-control lever.

### Operation Of The CdS-Cell Linkage

At first glance, the M5 shutter assembly, Fig. 18, looks strikingly familiar — at least, if you're acquainted with other M-series Leicas. The major difference — the photocell — now hides behind the lower light shield at the bottom of the shutter assembly.

Although the photocell doesn't yet show in the illustrations, you can see the **photocell-control lever** in Fig. 18.

One end of the photocell-control lever sits underneath the end of the flat release spring. The other end is underneath a tab on the photocell arm (the spring-loaded lever which carries the CdS cell).

Fig. 18 shows the parts in the shutter-released position. Notice that the **control-lever latch** now engages and holds the photocell-control lever. In turn, the photocell-control lever prevents the spring-loaded photocell arm from moving to the "reading" position.

Cocking the shutter disengages the control-lever latch. What happens is that the opening-curtain cam (attached to the opening-curtain

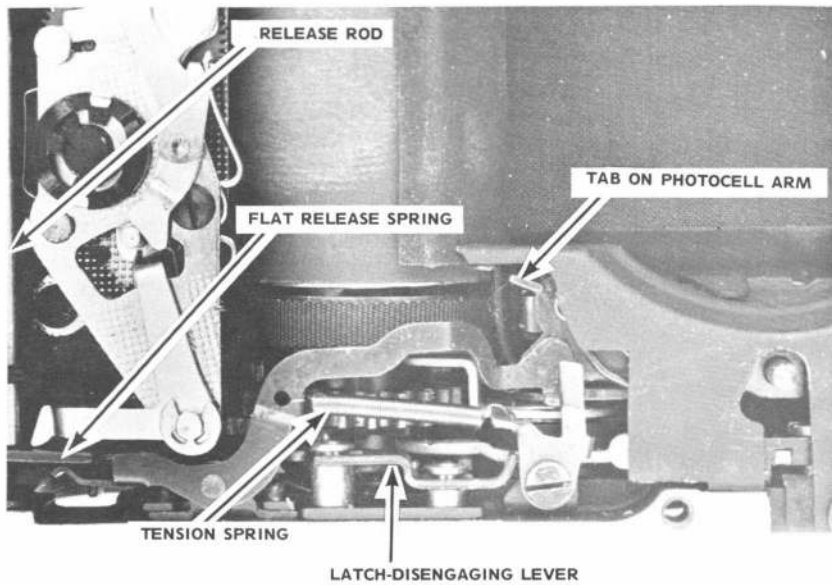

Figure 19

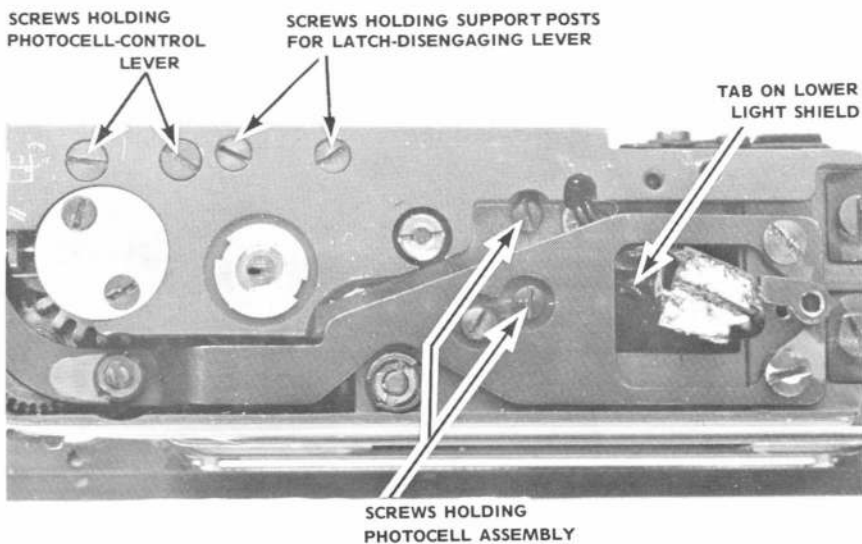

Figure 20

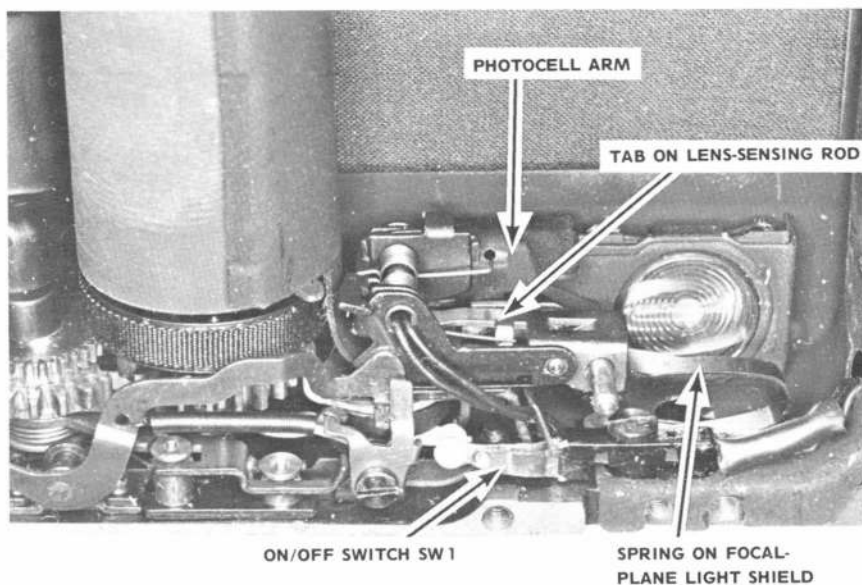

Figure 21

drum) drives the **latch-disengaging lever** from left to right in Fig. 19. The latch-disengaging lever then pushes the control-lever latch out of engagement with the photocell-control lever. Now, the photocell-control lever swings toward the bottom of the camera, Fig. 19.

If the lens were installed, the photocell could rise to the "reading" position — the photocell-control lever no longer blocks the tab on the photocell arm, Fig. 19. But without the lens, the spring on the lens-sensing rod overpowers the spring on the photocell arm. The lens-sensing rod must move down, toward the bottom of the camera, before the photocell arm can spring to the "reading" position.

Depressing the release button returns the photocell arm to the inactive position. Notice that the release rod comes against the end of the flat release spring, Fig. 19. As the release rod moves down, it pushes the end of the flat release spring against the left-hand end of the photocell-control lever. The right-hand end of the photocell-control lever then pushes up the tab on the photocell arm.

So the photocell arm swings clockwise as the release rod moves toward the bottom of the camera. The photocell arm completely clears the lower edge of the focal-plane aperture before the flat release spring disengages the opening-curtain latch.

Removing the lower light shield exposes the rest of the photocell-operating mechanism. One screw, Fig. 18, holds the front edge of the lower light shield. But after you remove the screw, you'll find that the lower light shield still clings to the shutter assembly.

The reason is that a tab on the lower light shield passes through a slot in the bottom of the focal-plane light shield. A twist in the tab holds the two light shields together. Right now, the tab is pretty well hidden from view; it's underneath the photocell's terminal plate. You can get to the tab a little more easily by first taking out the terminal-plate screw. Then, move the terminal plate aside as shown in Fig. 20.

Using your chain-nose pliers, straighten out the tab — just enough to allow the tab to pass through the slot in the focal-plane light shield. Now, cock the shutter and hold the lens-sensing rod toward the bottom of the camera; that raises the photocell arm

to the "reading" position, out of the way. Finally, lift out the lower light shield.

Fig. 21 gives you a better view of the remaining photocell linkage. The large, flat spring on the focal-plane light shield passes underneath the lens-sensing rod. So the flat spring pushes the lens-sensing rod toward the top of the camera. In turn, the tab on the lens-sensing rod, Fig. 21 holds down the spring-loaded photocell arm.

Installing the lens pushes down the lens-sensing rod. Consequently, the tab of the lens-sensing rod moves toward the top of the camera — away from the photocell arm. Providing the shutter is cocked, the photocell arm then flips up to the "reading" position.

The switch sitting to the front of the photocell is the on/off switch SW1, Fig. 21. In the shutter-released position, SW1 is open. Cocking the shutter pushes the opening-curtain brake lever against the insulated stud of the on/off switch — that closes the switch to turn on the exposure meter.

### Removing The Exposure-Meter-Linkage Assembly

The entire cross-coupling system mounts to a plate sitting above the rangefinder assembly. Here, Leitz again demonstrates its flair for excellent modular design — the linkage system comes out as a complete unit.

Removing the linkage system does disturb one timing point: the timing between the speed-sensing gear and the speed-setting ring. But Leitz demonstrates its service-conscious caliber with a factory-provided timing reference. Locate the dimple on top of the speed-setting ring. On reassembly, just engage the two parts with the dimples aligned.

To remove the film-speed dial, first lift off the index plate. Then, lift the film-speed dial up and off its support post. Our evaluation camera had a plastic washer on top of the index plate, a brass washer on top of the film-speed dial, and two steel washers on the shoulder of the support post.

Now, remove the dust seals fitting around the accessory shoe, Fig. 22. Lift the front edge of the accessory-shoe trim plate, Fig. 22, and slide the trim plate toward the back of the camera — that exposes the three screws holding the accessory shoe. Remove the three screws and lift the

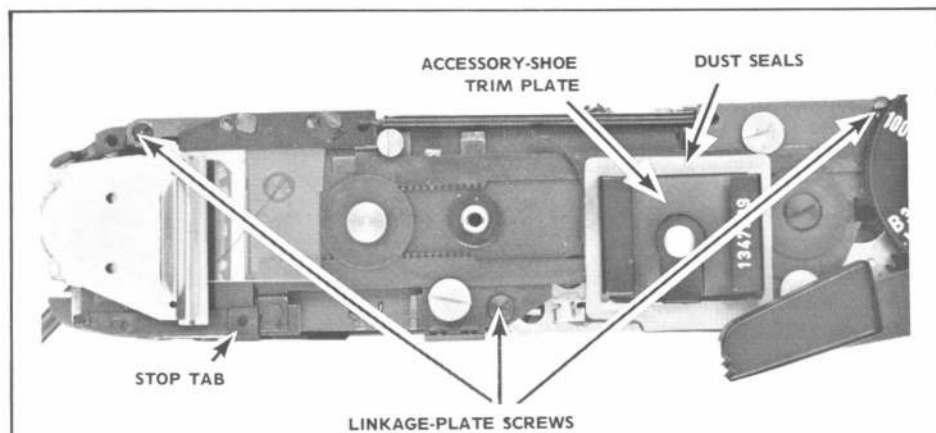

Figure 22

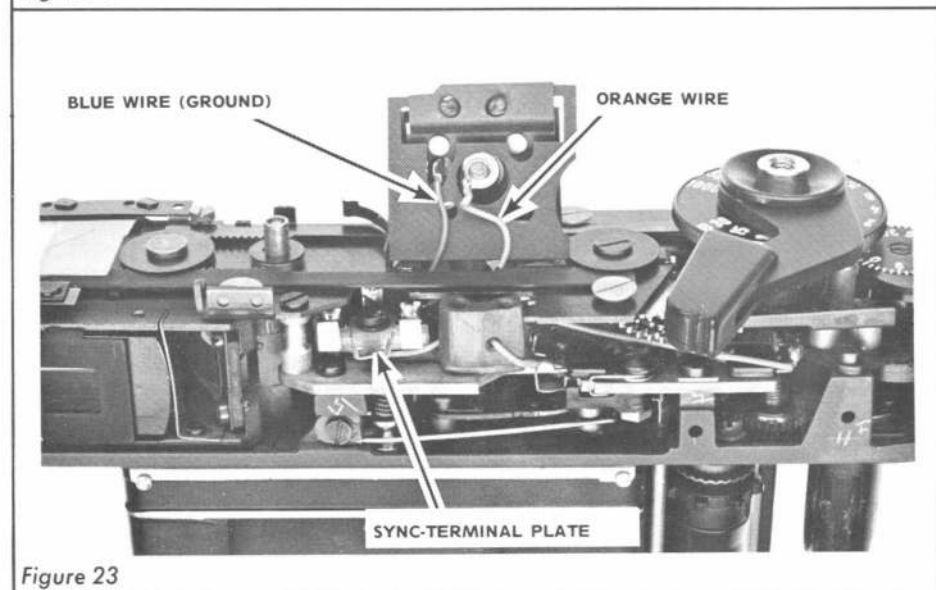

Figure 23

accessory shoe high enough to reach the hot-shoe wires, Fig. 23; be careful to avoid losing the spacers under the accessory shoe.

Unsolder the orange wire from the center terminal of the hot shoe. And unsolder the blue (ground) wire from the ground terminal, Fig. 23.

There's one more part that may get in the way of the linkage plate — the black frame around the eyelens. Notice that a tab extending from the eyelens frame serves as a stop for the speed-indicator rack, Fig. 22. Also, the tab tends to hold down the rack. So remove the eyelens frame by taking out its two screws.

Now, remove the three screws

holding the linkage plate, Fig. 22. And lift off the entire linkage assembly.

### Removing The Rangefinder Assembly

In most respects, the rangefinder is of the same design as in other M-series Leicas. The adjustment procedures are unchanged. Make your infinity and 10-meter rangefinder adjustments by turning the eccentric passing through the rangefinder-control-lever roller; make your one-meter adjustment by turning the eccentric located under the rangefinder-control-lever screw. The

vertical-alignment adjustment (the adjustment that doesn't depend on the distance setting) is the eccentric accessible after removing the plug screw in the top cover plate, Fig. 1.

There is, however, one new step required in removing the M5 rangefinder assembly. The viewfinder prism has an added attraction — another prism that catches the image of the exposure-meter scale reflected from the galvanometer mirror. The prism sits underneath the scale. So right now the galvanometer prevents you from lifting off the rangefinder assembly.

Notice that the two galvanometer retaining screws are sealed with red lacquer. As used throughout the M5, the red lacquer serves as a warning flag — meaning "a touch of a screwdriver disturbs an adjustment."

By loosening the two sealed screws, you can shift the galvanometer's position. The purpose is to properly align the exposure-meter scale in the viewfinder. Before removing the screws, you may wish to scribe the adjusted position of the galvanometer. Then, take out the screws and lift aside the galvanometer assembly.

Two wires still hold the galvanometer — the blue wire and the red wire from the circuit board. If you wish to remove the galvanometer completely, you'll have to unsolder the wires. However, in the illustrations we simply replaced the galvanometer with its two screws after we removed the rangefinder assembly.

As you remove the rangefinder-control lever, keep in mind that there's an eccentric under the retaining screw; you may wish to scribe its position. Also, take out the rangefinder-stop arm.

The rangefinder-stop arm comes against the eccentric that controls the rangefinder overtravel. As in other M-series Leicas, the screw passing through the overtravel eccentric helps hold the rangefinder assembly in position. The easiest way to remove the screw is to insert a long screwdriver through the hole in the bottom of the focal-plane light shield. Normally, you won't disturb the eccentric's position during disassembly — it comes out with the screw.

Now, remove the two screws from the supply-spool chamber and lift out the rangefinder assembly.

## Removing The CdS Cell And The Focal-Plane Light Shield

Getting down to the M5's shutter curtains requires a little more disassembly than in other M-series Leicas. The added complications are in removing the focal-plane light shield. To take out the focal-plane light shield, you must first remove some of the photocell parts.

Notice that one tension-type spring serves both the photocell-control lever and the control-lever latch, Fig. 21. Disconnect the spring from the control-lever latch. Now, remove the two screws holding the photocell-control lever — both screws are at the bottom of the camera, Fig. 20. Take out the photocell-control lever with the tension spring still attached.

Next, take a close look at the route of the photocell wires — from the photocell, through a hole in the focal-plane light shield, and through a hole in the bottom of the shutter assembly. From there, the wires pass underneath the flat release spring to the photocell's terminal plate.

Unsolder the two photocell wires from the terminal plate. Then, pull the wires to the inside of the camera and

through the hole in the focal-plane light shield. Take out the two screws shown in Fig. 20 and lift out the photocell assembly, Fig. 24.

To remove the on/off switch SW1, first slide back the tube to expose the front solder joint. Unsolder both wires from SW1. Then, remove the retaining screws and lift out the on/off switch. Pull the two wires through the hole in the focal-plane light shield to the take-up-rollers side of the camera.

Notice that we left both the control-lever latch and the latch-disengaging lever in the camera. If you do have to remove these parts for cleaning or replacement purposes, there are a couple of precautions we should mention. For one, notice that the spring for the opening-curtain latch hooks behind one of the support posts for the latch-disengaging lever. But you can remove the latch-disengaging lever without removing the longer of the two support posts — that way, the opening-curtain-latch spring remains hooked. Both support posts are held by screws at the bottom of the shutter assembly.

The other precaution involves the up-and-down sliding adjustments on the control-lever latch. The retaining screw for the control-lever latch

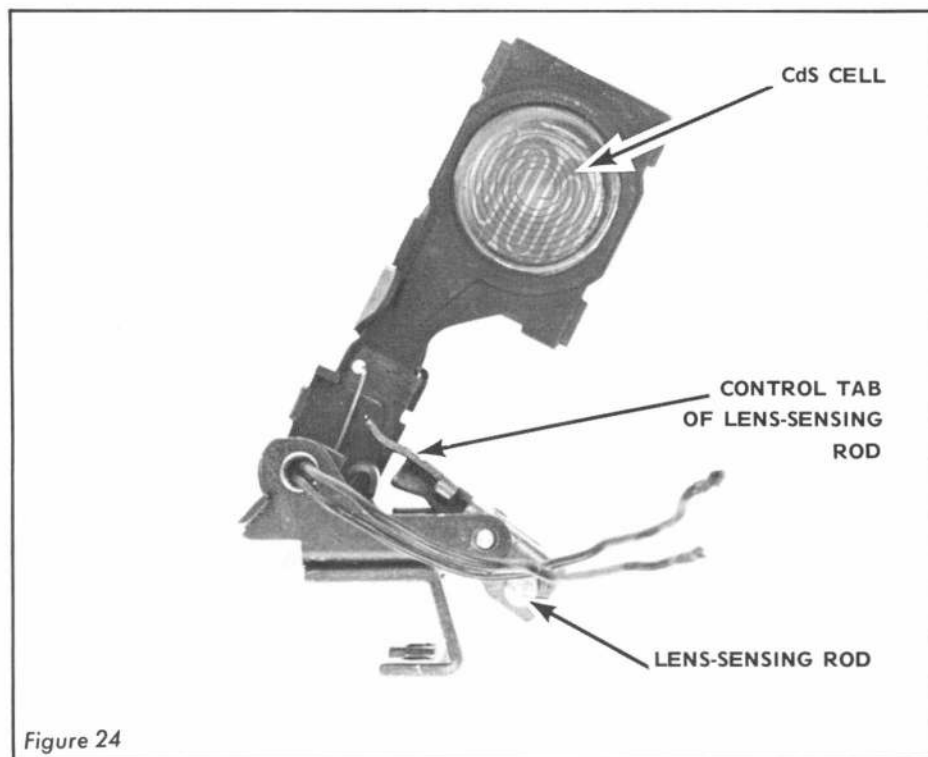

Figure 24

passes through a lug on the bottom of the camera and into a nut. If you loosen the screw, you can slide the control-lever latch up or down.

The control-lever latch must sit high enough that the CdS cell can't enter the focal-plane aperture with the shutter open. For example, suppose that the control-lever latch is sitting too low. Checking the shutter on "bulb," the photocell arm moves down — clear of the focal-plane aperture — as you depress the release button. But as you let up the release button, the photocell arm moves into the aperture before the closing curtain releases.

What's happening is that the control-lever latch engages the photocell-control lever. And the photocell-control lever blocks the photocell arm. However, the photocell-control lever fails to block the photocell arm soon enough — it's allowing enough travel for the photocell to re-enter the focal-plane aperture.

To correct the problem, just loosen the screw holding the control-lever latch. Then, slide the control-lever latch toward the top of the camera. The photocell-control lever must arrest and hold the photocell arm before the photocell enters the focal-plane aperture.

But you can remove the focal-plane light shield without disturbing the control-lever-latch adjustment. First, cock the shutter. You can then swing the control-lever latch clockwise until it clears the focal-plane light shield. In the shutter-released position, the closing-curtain brake lever may prevent the control-lever latch from moving clockwise.

Now, remove the two retaining screws and lift the focal-plane light shield out of the camera.

## Speed-Control Mechanism In The M5

At this point in disassembly, the M5 looks nearly identical to its M-series stablemates, Fig. 25. The satin-smooth shutter, a Leica hallmark, is still the familiar, time-proven showcase of Leica quality. Notice that the curtain-wind parts at the bottom of the camera reveal hardly any design changes.

Yet even here — in what's apparently familiar territory — there are a couple of variations from the design we described in an earlier **Craftsman** article. One change is in the method of relaying the shutter-

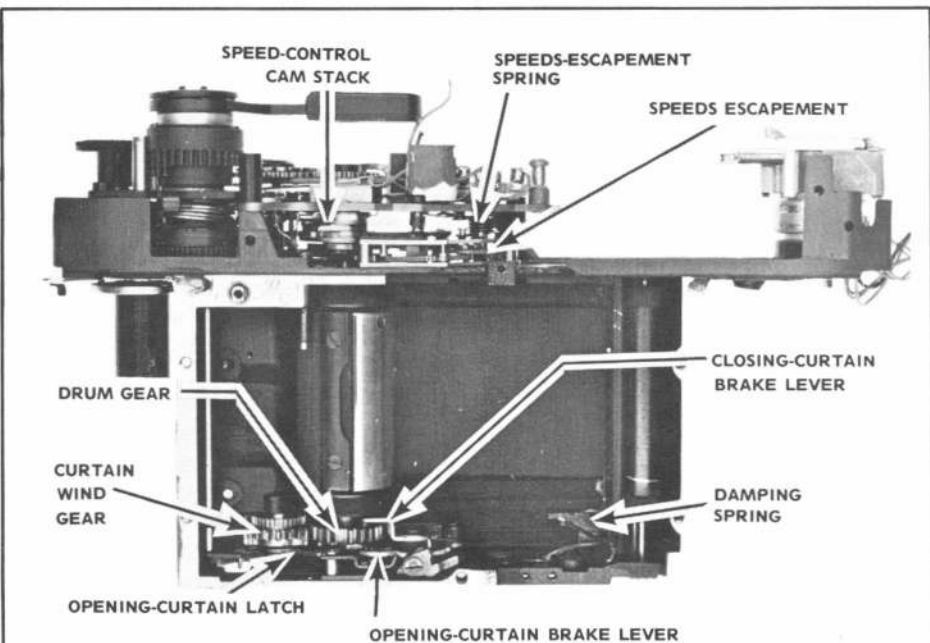

Figure 25

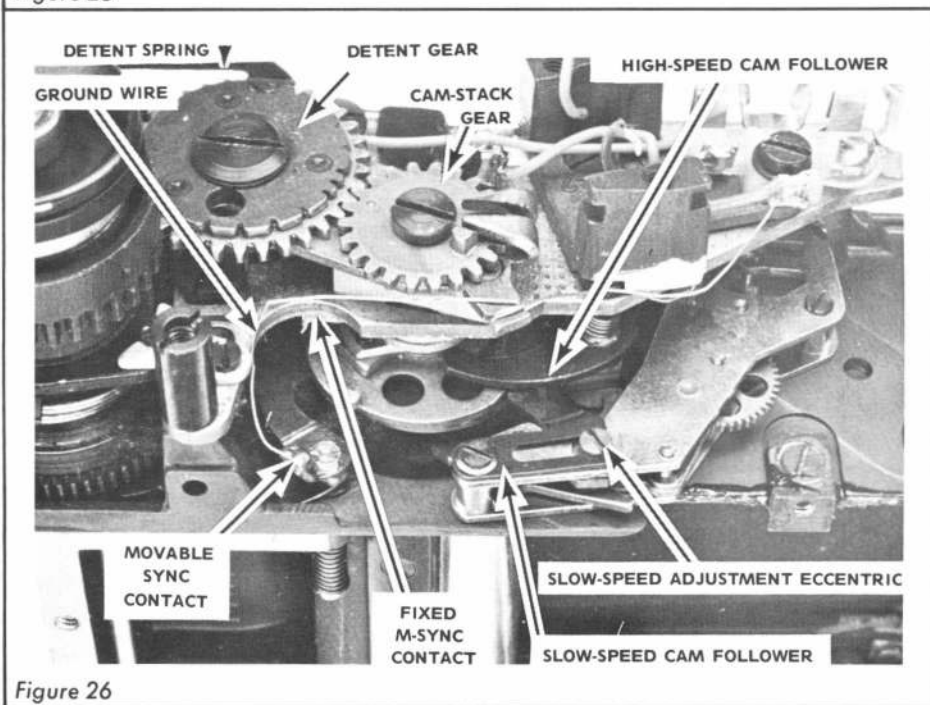

Figure 26

speed setting to the speed-control cam stack.

The speed-setting ring has two jobs — it selects the shutter speed and simultaneously signals the exposure-meter linkage as to the shutter-speed setting. The teeth of the speed-setting ring engage the **detent gear**, Fig. 26. And the detent gear turns the **cam-stack gear** attached to the top of the speed-control cam stack.

At the "bulb" setting, the detent spring drops into the large slot in the detent gear, Fig. 26. The stud on the cam-stack gear is now against the

stop on the speed-control bridge. Consequently, the cam-stack gear can't turn past the "B1" position. Yet you can still turn the speed-setting ring to the other "bulb" settings — even though the detent gear and the cam-stack gear remain as shown in Fig. 26.

The reason is that the teeth on the speed-setting ring are cut away for a short distance at the bottom. So there's a section of the speed-setting ring at which the teeth extend only part way down — that section indicates the range of "bulb" settings.

At the "bulb" settings, the speed-setting ring continues to turn the speed-sensing gear and thereby controls the exposure-meter linkage. But the teeth disengage from the detent gear.

There's also a change in the speeds escapement. The pallet in the M5 doesn't disengage for a separate speed range — it remains constantly engaged with the star wheel. Different slow speeds result from varying the depth of engagement between the retard lever and the closing-curtain cam.

Yet the slow-speed and slit-width adjustment points are the same as in other M-series Leicas. The eccentric on the closing-curtain latch, Fig. 15, controls the slit width. And the eccentric on the slow-speed cam follower, Fig. 26, positions the end of the speeds escapement for the slow-speed range.

Getting to the pivot screw for the speeds escapement now requires that you lift aside the sync-terminal plate, Fig. 23. Then, you can reach the red-lacquered screw. To remove the speeds escapement, disconnect the speeds-escapement spring, Fig. 25, from the speed-control bridge and take out the pivot screw.

The adjustment technique for the pivot screw appears unchanged. On reassembly, replace the pivot screw and hook the speeds-escapement spring. Then, tighten the pivot screw until the speeds escapement is unable to move toward the speed-control cam

stack. Finally, back off the pivot screw until the speeds escapement swings against the speed-control cam stack under its own spring power.

### Sync Circuit In The M5

Adding the photocell required some significant modifications to the sync section. The X-sync contacts no longer sit at the bottom of the camera — the photocell linkage needed the room. So Leitz put the X-sync contacts at the top of the camera, next to the M-sync (or, if you prefer, FP-sync) contacts.

With a stroke of genuine ingenuity, Leitz took advantage of an existing part — the movable M-sync contact — to close the X-sync circuit. So now the movable M-sync contact serves double-duty: it closes both sync circuits, X and M, during every release cycle.

In Fig. 26, you can see the movable sync contact ("movable M-sync contact" is no longer an appropriate term, since the contact serves two circuits). The fixed M-sync contact is also visible in Fig. 26. But the fixed X-sync contact is underneath the speed-control bridge; you can't see it in the illustrations.

Fig. 26 shows the shutter in the released position. Here, the movable sync contact swings to the left (as seen from the front of the camera) — against the fixed X-sync contact. As you cock the shutter, the movable sync contact moves away from the fixed X-sync contact.

Even though the X-sync contacts touch in the shutter-released position, the X-sync circuit isn't complete — a safety switch breaks the circuit. The movable blade of the safety switch sits on top of an insulator attached to the closing-curtain latch. During the release cycle — as the closing-curtain latch moves down to catch the closing-curtain cam — the safety switch closes.

The release of the opening curtain then dictates the action of the movable sync contact. The arm of the movable sync contact rides against the **sync cam**, a cam attached to the opening-curtain-drum shaft. You can spot the sync cam by looking underneath the release cam — the release cam is the part that strikes the disengaging lever to free the closing curtain.

First, the movable sync contact swings to the right in Fig. 26 — against the fixed M-sync contact. So a flash unit hooked to the M-sync circuit fires when the opening curtain starts its travel. Then, as the opening curtain nears the end of its travel, the sync cam drives the movable sync contact to the left in Fig. 26. This time, the movable sync contact strikes the fixed X-sync contact.

As you can see in the schematic, Fig. 27, the movable sync contact strikes two fixed X-sync contacts at the same time. One fixed X-sync contact is wired to the X-sync terminal; the other fixed X-sync contact goes to the hot shoe. A separate circuit for the hot shoe means that you can fire two electronic-flash units at the same time.

You'll also notice in Fig. 27 that there's a second safety switch — this one for the M-sync circuit. Like the X-safety switch, the M-safety switch depends on the downward travel of the closing-curtain latch. Both movable safety-switch blades sit on the same insulator, one beside the other. So the downward travel of the closing-curtain latch allows the two safety switches to close simultaneously.

Why a safety switch for the M-sync circuit? The M-safety switch becomes important at the fast shutter speeds. In the M5, changing the shutter-speed setting varies the actual length of the M-sync delay. Despite its name, the fixed M-sync contact isn't all that fixed in position. Rather, it's spring-loaded, riding against a cam on the speed-control cam stack.

Changing the shutter speed presets

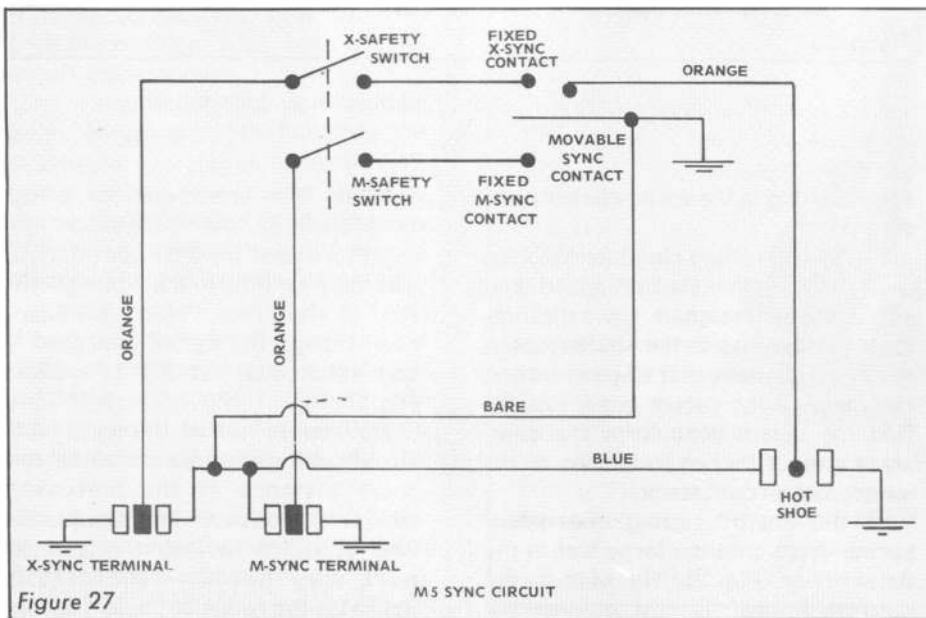

the distance between the movable sync contact and the fixed M-sync contact. The faster the shutter speed, the closer the fixed M-sync contact moves toward the movable sync contact — and the longer the resulting M-sync delay.

With our evaluation camera set to "bulb," the opening curtain moved 3mm past the opening side of the focal-plane aperture when the M-sync contacts closed. Yet at 1/1000 second, the M-sync contacts closed the instant the opening-curtain latch released the opening curtain. In fact, the fixed M-sync contact touched the movable sync contact in the shutter-cocked position. So closing the safety switch simultaneously closed the M-sync circuit.

### Conclusions On The M5

From the outside, the M5 may look like an all-new design. And the clamor over the exposure-meter system makes it sound that way. So much so that many Leica sentimentalists mourn the passing of the M4. Some feel that the M4 should have been kept around as a less-expensive alternative — others say that the M4 should make a comeback and reclaim its throne as the top-of-the-line rangefinder Leica.

But just a glance under the M5's cover plates reveals that the M4 is still with us — updated for the swing of today's camera trends. The new exterior houses the esteemed shutter and rangefinder made legend by earlier members of the M-series household. From a service viewpoint, that's a welcome sight.

(from page 15)

### PRACTICAL OPTICS

Now, turn over the lens and unscrew the identification ring around the front lens element; the identification ring has two spanner notches. One caution before you lift off the filter ring — there's a ball detent (for the diaphragm settings) that'll be loose. Lift off the filter ring and locate the keying lug — the lug on the filter ring passes within a slot in the inner lens barrel.

The ball detent sits within a hole in the diaphragm-setting ring. Lift off the ball detent and its compression spring. Then, lift off the diaphragm-setting ring. The brass screw inside the diaphragm-setting ring passes through the fork extending from the

diaphragm-cam ring.

Next, unscrew the front lens cell; use the outer spanner notches to unscrew the front lens cell as a complete unit. You can now see the diaphragm-cam ring. The diaphragm-cam ring positions the cam follower on the aperture-control lever — that determines how far the lens can stop down. Notice that the cam follower traces against the inside circumference of the diaphragm-cam ring.

Remove the two brass screws holding the diaphragm-cam-ring coupling fork. Then, lift out the coupling fork (that's the fork that engages the diaphragm-setting ring). The other two brass screws hold the lug that connects the diaphragm-cam ring to the diaphragm-lug ring. An eccentric controls the position of the coupling lug.

You can remove the diaphragm-cam ring without taking off the coupling lug — and without disturbing the adjusted position. Just turn the diaphragm-cam ring counterclockwise (toward the smaller aperture setting) until the coupling lug reaches a special clearance cutout in the diaphragm-mounting plate. Then, lift out the diaphragm-cam ring. On reassembly, you'll have to hold the cam follower against its spring tension as you seat the diaphragm-cam ring — the pin on the cam follower must ride to the inside edge of the diaphragm-cam ring.

If you wish, you can now remove the diaphragm-control levers for cleaning. To reach the diaphragm leaves, turn over the lens and take out the three cross-point screws; these screws hold the diaphragm-mounting plate. The complete diaphragm assembly now slides out, toward the front of the lens. On reassembly, there's only one position at which the three screw holes in the diaphragm-mounting plate will align.

Watch out for the three brass spacers that sit between the diaphragm-mounting plate and the diaphragm-cover plate — they're now loose. Looking from the back of the diaphragm assembly, the spacers fit shoulder-up beneath the diaphragm-cover plate.

Three screws hold the diaphragm-cover plate. Once you remove the diaphragm-cover plate, you can take out the eight diaphragm leaves for cleaning or replacement purposes. On reassembly, replace the leaves in clockwise rotation. ♦

## THE FAMOUS

# Nat Cam Manuals

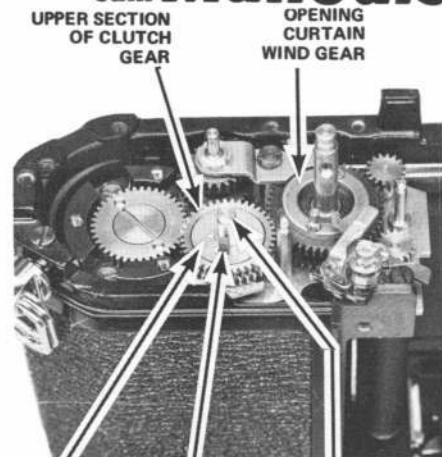

Completely researched, clearly and fully illustrated, detailed step-by-step instructions on disassembly and reassembly, timing, lubrication, and testing procedures. These service manuals are invaluable even to the very experienced technician. All excellent additions to your technical library.

### PENTAX H3v

Considered by many technicians to be the most representative of all double-roller single lens reflex cameras. Includes curtain travel test procedures applicable to any focal-plane shutter.

NC No. 442

\$19.60

### LEICA IIIIf

Includes variations between "red dial" Leica IIIIf models and provides background applicable to many other cameras using similar shutters.

NC No. 327

\$14.95

### KODAK INSTAMATIC 100

Many complex models of the basic cartridge-load camera use the same or similar mechanisms for film transport, shutter wind and flash synchronization.

NC No. 258

\$3.00

### PRONTOR 500 LK

#### PROGRAMMED SHUTTER

Also includes adaptation of this shutter to a programmed exposure system.

NC No. 276

\$7.95

### SYNCHRO - COMPUR 00-MXV WIDE REFLEX

Covers the shutter used on semi-automatic SLR cameras such as the Kodak Retina Reflex and the Voigtlander Bessamatic, unique for its complex light value "computer" mechanism.

NC No. 328

\$8.95



**National Camera**

2000 West Union Avenue Dept. QCC  
Englewood, Colorado, 80110 U.S.A.