

# FUJICA ST801

Similar models: other ST SLRs and AZ (mechanically similar)

Battery: 1 ea. BV PX28 or 544 (negative ground)

Fig. 1—top cover removed

Fig. 2—back of camera

Fig. 3—bottom cover removed

Fig. 4—front plate removed, wind side of mirror box

Fig. 5—front plate removed, rewind side of mirror box

Fig. 6—shutter mechanism, top view

Fig. 7—shutter mechanism removed, back view

Fig. 8—charge-cam timing

Fig. 9—amplifier unit 2-87-5, bottom view

Fig. 10—LED display, test voltages

Fig. 11—wiring pictorial and voltages, version 5 of amplifier

Fig. 12—wiring pictorial, versions 1 and 2 of amplifier

Fig. 13—wiring variations, versions 3 and 4 of amplifier

Fig. 14—wiring variations, LSI

Fig. 15—wiring, f-value resistor

Fig. 16—wiring variations, shutter resistor

Fig. 17—component compatibility chart

## ADJUSTMENT LOCATIONS:

Amplifier voltage	A
LED readout	B
Capacitor-charge time	C*
Shutter-resistor voltage	D
1/30 second	E

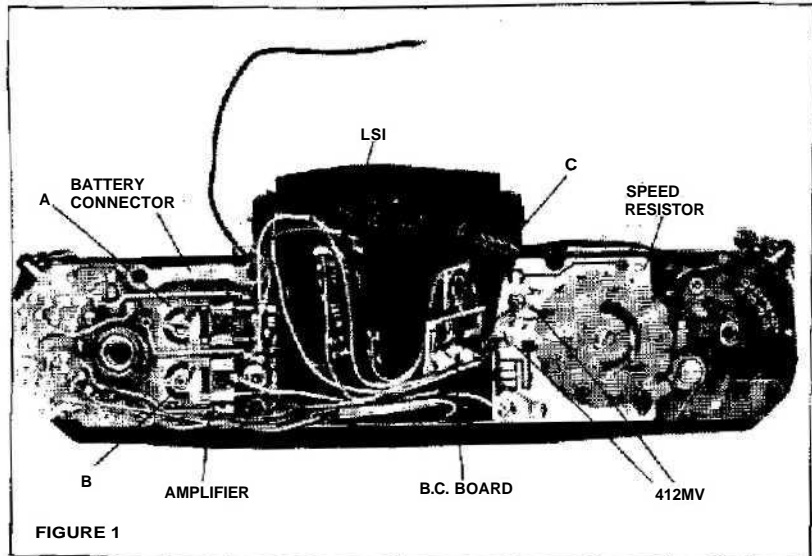

FIGURE 1

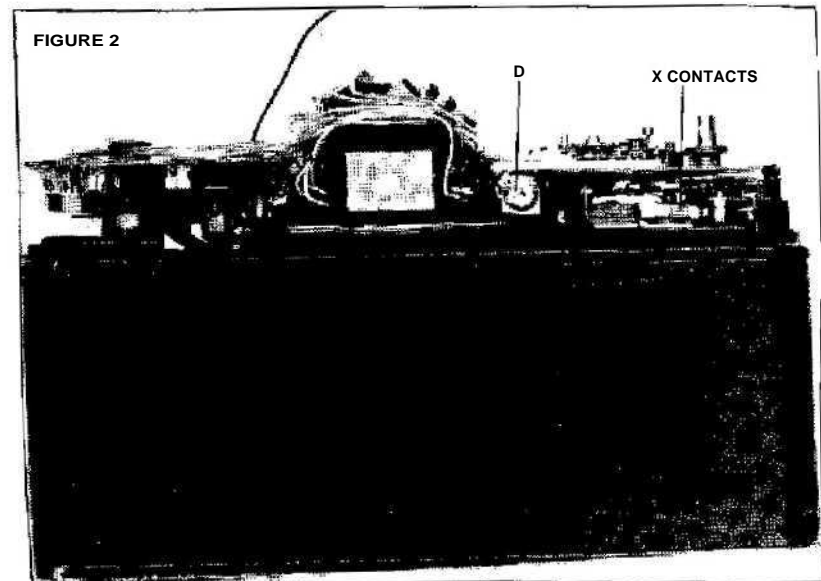

FIGURE 2

Retard overtravel  
 Travel time, second curtain  
 Travel time, first curtain  
 Meter switch  
 F-value resistor  
 Engagement, second-curtain latch  
 Brake, first-curtain  
 1/2000 second  
 \*Do not disturb.

## ADJUSTMENT VALUES:

F	Curtain-travel time:	12ms
G		(32mm distance)
H		
I	Flange-local distance	45.45±
J		0.02mm (flange to film-guide rails)
K	X-time delay:	0.6 -1.5 (adjust by bending X-sync contacts, Fig. 2)
L		
M		
	Curtain timing:	

Second curtain—3.5mm behind the lead edge of the aperture, shutter

held open by second-curtain latch, Fig. 7; adjust by changing the timing of the second-curtain wind gear.

First curtain—1-bar overlap during cocking cycle; adjust by changing the timing of the first-curtain wind gear.

Speed indicator:

Rotate the speed selector until the speed indicator reads "500." Then lock the speed indicator in place by inserting the end of a paper clip into the hole, Fig. 6.

Meter switch;

Adjust by bending the switch so that the meter switch, Fig. 4, closes before the shutter releases.

F-value resistor;

Adjust by loosening the screws and sliding the resistor board, Fig. 5, so that the brush contacts engage the first resistance path as shown.

Retard overtravel:

With the shutter cocked and set to 1/30 second, there should be a slight space gap between the lug on the retard-drive gear and the edge of the retard lever. Also, the corner of the retard lever should just be in the path of the retard-drive lug. You can change the depth of engagement to adjust 1/30 second, and you can change the overtravel (space gap) to adjust the speeds of 1/15-1/8 second.

#### ADJUSTMENT SEQUENCE:

##### A. Shutter speeds

1. Set the curtain-travel times at 1/2000 second. A tension change of one tooth on the ratchet equals a travel-time change of approximately 0.1ms.
2. Check 1/2000 second. To adjust, remove the high-speed cam (center screw), Fig. 6, and rotate the cam on the first-curtain wind gear after loosening its screws. Fig. 7, Rotating the cam counter-clockwise provides a faster shutter speed. You may also be able to adjust the fast speed with the eccentric on the second-curtain latch (K in Fig. 6).

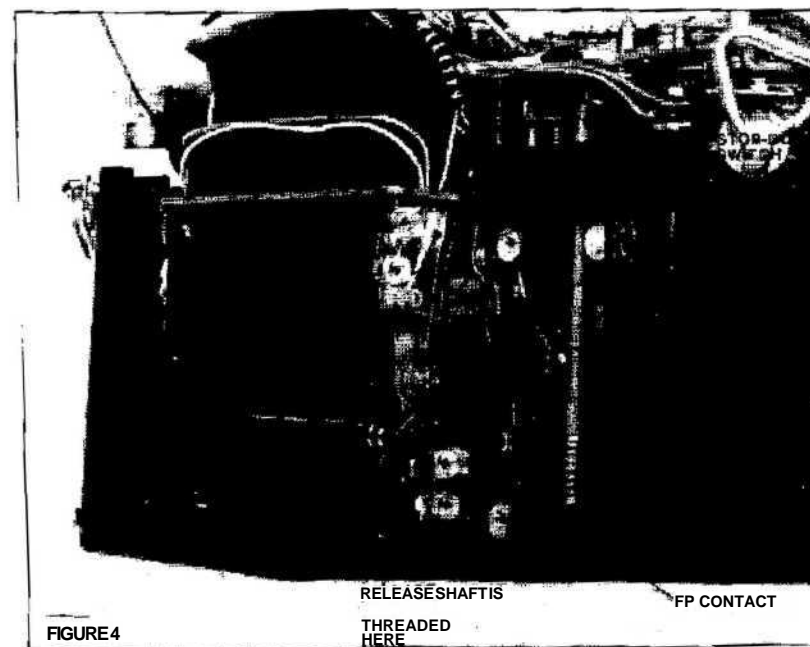
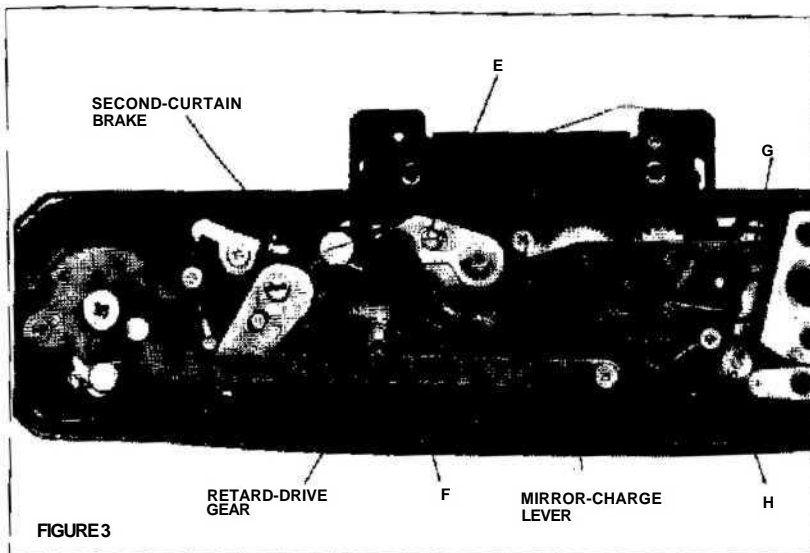

3. Decreasing the depth of engagement provides a faster shutter speed.
3. Check 1/60 second.
4. Adjust 1/30 second with eccentric E, Fig. 3. Then lock the eccentric with cement. You can make a rough adjustment by bending the slow-speed cam follower, Fig. 6. Adjust so that the lug on the retard-drive gear just catches the corner of the retard lever at 1/30 but clears the retard lever at 1/60. Make the fine adjustment for 1/30 with eccentric E.
5. Check the other slow speeds. You can adjust 1/15-1/8 by changing the retard overtravel. Adjust 1/4-1

- by changing the pallet engagement (bend the pallet-stop bar).
- ##### B. Meter
- Note; The meter adjustments require connecting a 6V power supply to the amplifier board. Connect the positive power-supply lead to the battery connector. Fig. 1. Connect the negative power-supply lead to ground. Push the release shaft to close the meter switch. Alternately, you can bypass the meter switch by connecting the positive power-supply lead to the red wire (point #1), Fig. 11. Then you don't have to hold down the release shaft.
1. Measure the voltage across vari-

able resistor A, Fig. 1, with a digital meter. Adjust A for a reading of  $1360 \pm 50$ mv.

2. Measure the voltage between the two shutter-resistor connections shown in Fig. 1 (blue wire and red wire). Adjust C for a reading of 412mv.
3. Temporarily install the top cover and the battery. Set 1/60; ASA 100, and f/5.6. Check the LED indication at a light level of EV11; the center LED should turn on. If not, remove the top cover and adjust variable resistor B. Turning the wiper clockwise moves up the indication.

#### DISASSEMBLY HIGHLIGHTS:

Settings: 1/60 second, ASA 100 (for reference)

#### Sequence:

1. bottom cover
2. top cover (do not remove speed knob)
3. unsolder sync wire from hot-shoe contact
4. front leatherette
5. front plate (4 screws)—spacer washers and self-timer coupler loose

#### Sequence to remove shutter;

1. unsolder wires from amplifier
2. amplifier board (1 screw)
3. unsolder wires from speed resistor
4. set speed selector to 1/2000
5. speed-resistor plate (3 screws)—speed-indicator gear and coupler to speed selector loose
6. cam attached to wind shaft (1 screw)
7. counter assembly (unscrew 2 support posts, unsolder red wires from meter switch)
8. counter-advance cam on wind shaft (looser setscrew)
9. unscrew upper section of release shaft from lower section, Fig. 4—remove both sections
10. self-timer (2 screws—do not remove upper screw holding plates together)
11. first-curtain brake spring (screw, plastic cylinder, compression spring, washers, Fig. 6)
12. X-contact assembly (2 screws)—spacer loose

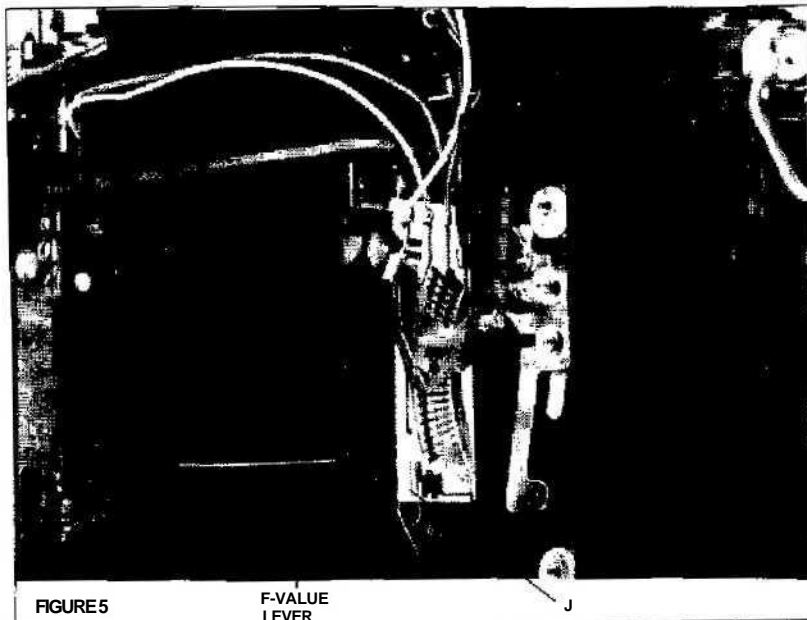

FIGURE 5

F-VALUE  
LEVER

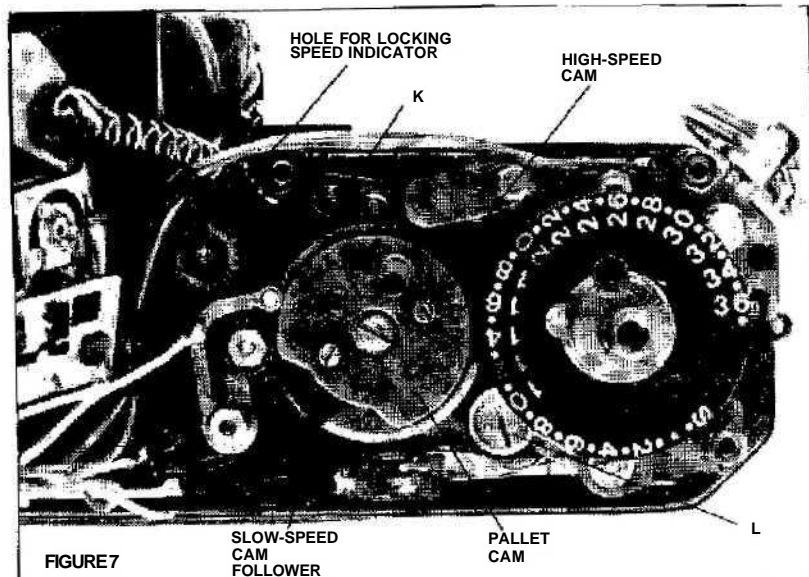

FIGURE 7

SLOW-SPEED  
CAM  
FOLLOWER

PALLET  
CAM

13. curtain-charge gear (E-ring)
14. charge cam, Fig. 8
15. lift out first-curtain brake lever (leave spring attached)
16. screw holding mirror-charge lever, bottom of camera, Fig. 3
17. swing aside mirror-charge lever—rewind button and compression spring loose
18. second-curtain brake lever and mirror latch (1 screw and spring, bottom of camera)
19. unsolder black FP-sync wire from upper connector to front plate, Fig. 5
20. 4 screws holding shutter assemb-

- ly, top of camera (one screw also holds a wire clamp, one holds a shutter-retaining clamp)
21. shutter/mirror-box assembly from top of camera

#### To time shutter curtains, also remove:

1. retard-drive gear, bottom of camera
2. pallet and slow-speed cam followers, top of camera
3. high-speed cam (1 screw)—high-speed cam follower and compression spring loose

## REASSEMBLY HIGHLIGHTS:

- 1- Cock the shutter by rotating the first-curtain wind gear before you install the shutter/mirror-box assembly in the body casting.
2. Seat the first-curtain brake lever. Then install the charge cam with its lug pointing to the hole for the release shaft, Fig. 8. If the shutter is still cocked, seat the curtain-charge gear with its downward-projecting pin against and clockwise of the charge-cam lug (counterclockwise of the charge-cam lug if the shutter is in the released position).
3. To install the speed-resistor plate, first rotate the high-speed cam to the 1/2000-second position (the high-speed cam then pushes down the high-speed cam follower the maximum amount). Replace the coupler on top of the pallet-control cam. Seat the speed-indicator gear in the hole of the speed-resistor plate. As you seat the speed-resistor plate, make sure the pins on the speed selector pass into the slots in the coupler; you may have to rotate the high-speed cam slightly so that the slots in the coupler align with the speed-selector pins. Replace the screws holding the speed-resistor plate and time the speed indicator as described under "Adjustment Values."
4. Before replacing the front plate, install the self-timer coupler on the self-timer cocking shaft. Use the self-timer coupler to cock the self-timer. Then rotate the f-value ring fully counterclockwise (as seen from the front of the front plate). As you seat the front plate, pull down the f-value lever; the f-value lever then couples under the pin on the f-value ring. Release the self-timer and turn the self-timer cocking lever until it's picked up by the coupler.
5. Push down the rewind button (latched position) before replacing the bottom cover.

## TROUBLESHOOTING:

Behavior without battery; no LEDs  
Current draw (6V supplied): 6.5 - 7ma

## Testing major components;

1. Amplifier. Measure the input at the blue wire (2.4V, f-value

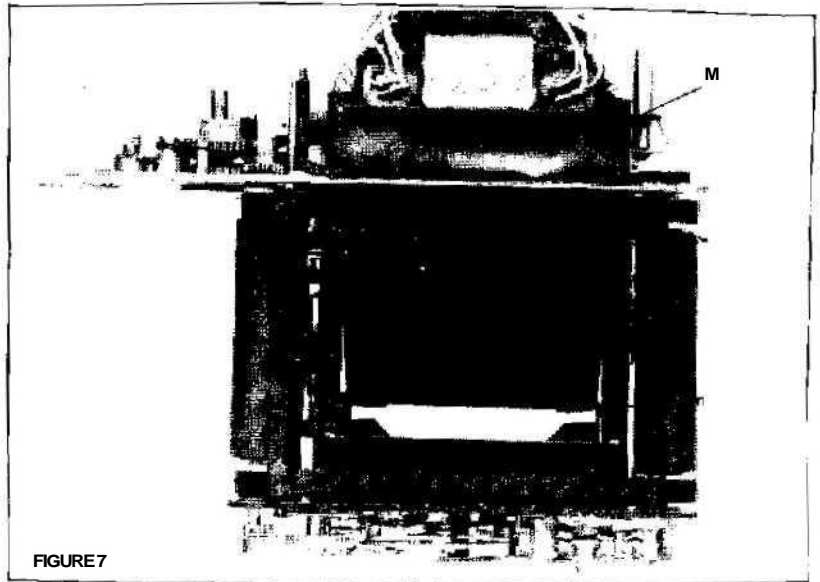

FIGURE 7

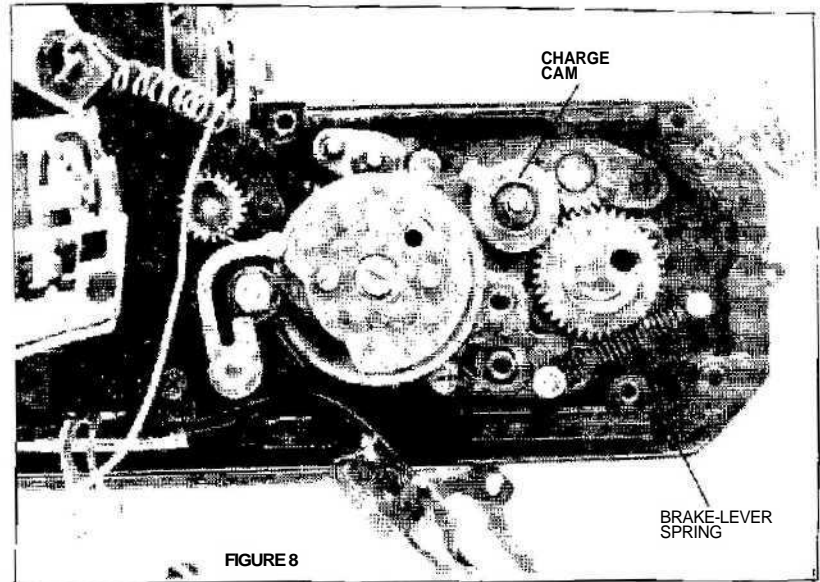

FIGURE 8

2. resistor) and at the yellow wire (2.2V, shutter resistor), Fig. 11. Check the output of the amplifier at terminal #8, Fig. 11 (yellow wire). The voltage at the output should change as you change the light level, the film-speed setting, or the aperture setting. As the light level increases, the voltage should go more positive.
2. LSI. Connect 6V to the battery connector. Then connect a second DC power supply between ground and the input (yellow wire) of the LSI. With a voltage setting of 3V, the center LED should turn on. The other LEDs should turn on with the voltage settings shown in Fig. 10.
3. B.C. board. Slowly decrease the voltage applied to the battery connector while watching the LEDs. The LEDs should cut off suddenly when you reach a setting of around 5V. If the LEDs gradually decrease in brightness and then turn off, the B.C. board may be defective. A defective B.C. board could also cause a failure of the LEDs to turn on. Measure the voltage between the yellow wire and the white wire of the B.C. board with 8V applied to the battery connector; you should measure around 4.8V. A low voltage reading could indicate a defective B.C. board.

Troubleshooting steps for specific problems:

1. LEDs do not turn on

Meter switch, poor contact

Apply 6V to the battery connector. Measure the voltage to terminal #1, Fig. 11. with the release shaft pushed half way. You should measure the battery voltage. No voltage—meter switch or wiring.

B.C. board or LSI

Measure the voltage between the yellow wire and the white wire of the B.C. board, Fig. 1. Less than 4.8V—B.C. board defective. More than 4.8V—LSI defective.

2. Only top or bottom LED turns on

Shutter resistor (top LED)

Measure the voltage to the yellow wire from the shutter resistor at the amplifier, Fig. 11. You should measure around 2.2V. A very low voltage normally indicates an open or poor contact in the shutter resistor.

F-value resistor or stop-down switch (top LED)

Measure the voltage at the blue wire indicated "2.4V" in Fig. 11. A low voltage normally indicates poor contact in the f-value resistor or in the stop-down switch,

Amplifier

LSI

REVISED PARTS;

1. The B.C. board was added in later models, Fig. 1, to shut off the LEDs when the battery voltage drops too low. In the most recent version, the B.C. unit is part of the LSI.
2. The CR board (capacitor-variable resistor) was first added as a separate board, Fig. 1, and later built into the LSI.
3. The amplifier has several revisions. The first three versions share two discrete FET's on the bottom of the board. Later units replace the FET's with an IC. Some—but not all—versions will interchange. Specify the camera serial number (on back cover) when ordering a replacement. If the

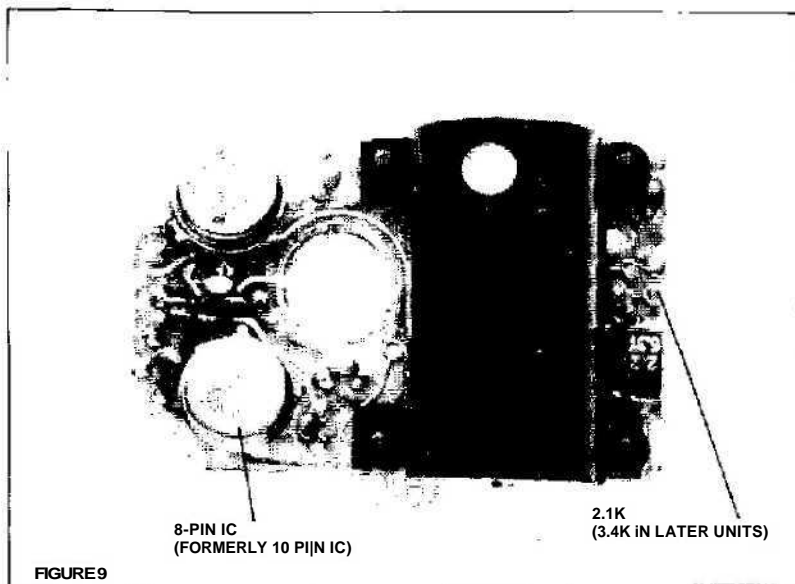

replacement needed is not available, it may be necessary to replace the LSI unit, the shutter resistor, and/or the f-value resistor to be compatible with the new amplifier. The chart, Fig. 17, shows which components are compatible according to camera serial numbers. Amplifier variations:

Version #1 (2-87-1)—two FET's on bottom of board, 22K variable resistor closer to front of camera (not available as replacement.).

Version #2 (2-87-2)—two FET's on bottom of board, 6.6K variable resistor closer to front of camera. Wiring is the same as in version #1.

Version #3 (2-87-3)—two FET's on bottom of board, but wiring pattern changed. See Fig. 13.

Version #4 (2-87-4)—FET's replaced by 10-pin IC. See Fig. 13 for wiring.

Version #5 (2-87-5)—10-pin IC replaced by 8-pin IC, Fig. 9, Wiring pattern matches Fig. 11.

Version #6 (2-87-6)—eliminates the capacitor on the top side of the board. See Fig. 11 for wiring.

Version #7 (2-67-7)—resistor shown in Fig. 9 changed from 5.1K to 2.4K. Wiring is the same as for version #6.

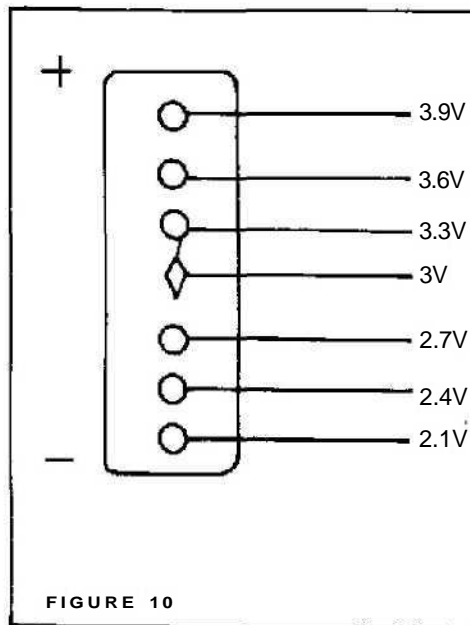

- Also, Fujica provides a version #8 amplifier unit for replacement purposes. Version #8 has the 2.4K resistor. Fig. 9, and a 1000 pF capacitor (top side of board) for phase compensation. Wiring is the same as version #6. If you install version #8 in a camera with a serial number up to 905XXX, change the combination of the shutter resistor and the f-value resistor to match serial 4906XXX and later, Fig. 17. If you install version #8 in a camera that has a serial number 305XXX or later, remove the 1000 pF capacitor,
4. The LSI has several revisions. In the first two versions, Fig. 14, the comparator IC and the LED display are on separate boards

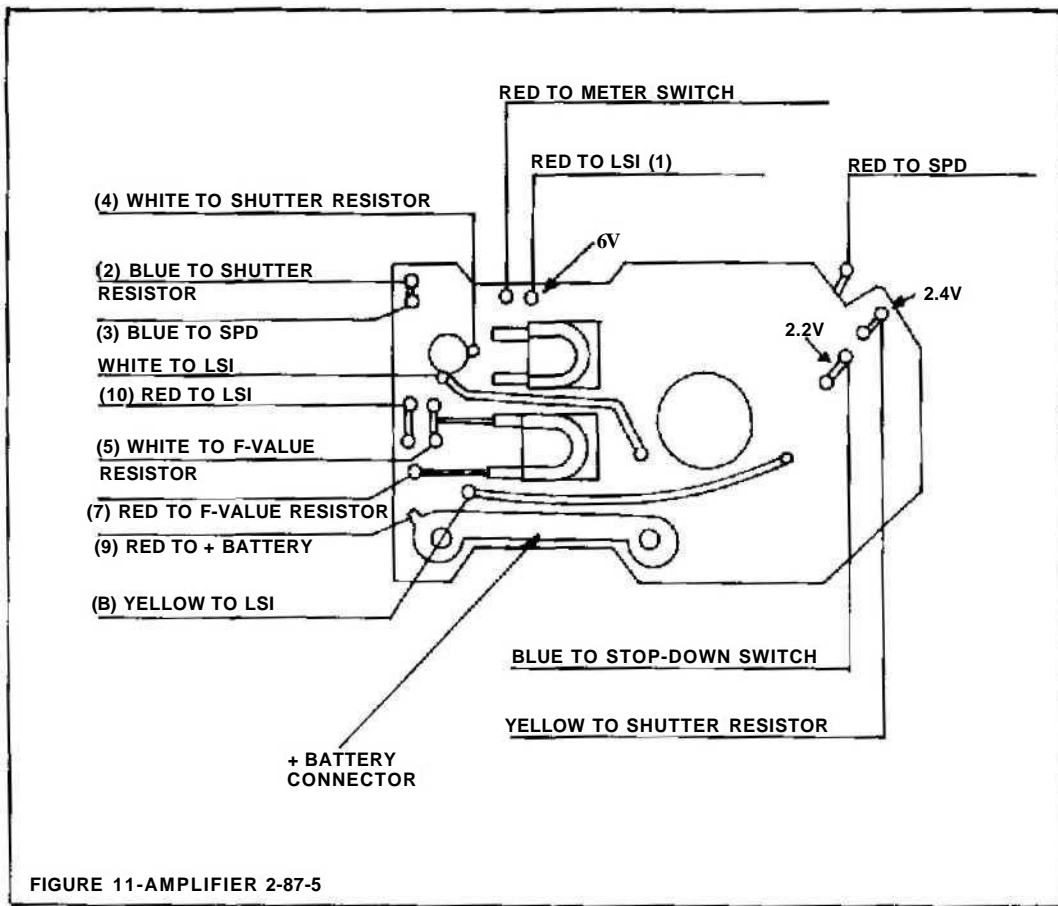

FIGURE 11-AMPLIFIER 2-87-5

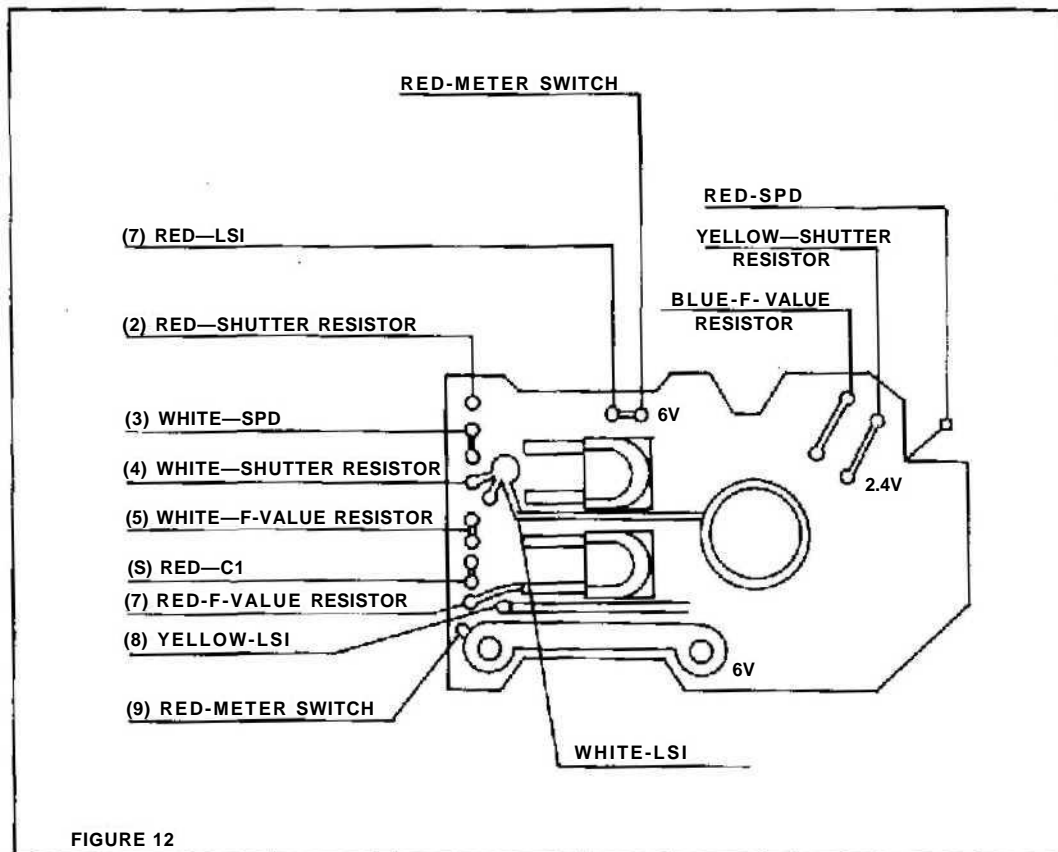

FIGURE 12

connected by wires. The later versions mount both the comparator IC and the LED display on a flex circuit, Fig. 1. Specify the camera serial number or refer to the chart, Fig. 17, when ordering a replacement. LSI 3-23-4 adds the CR board above the B.C. board. LSI 3-23-5 has both boards built into the flex.

5. The new-style f-value resistor has added one terminal, Fig.15, for sloped-down metering compensation. The earlier f-value resistor (5-75-1) has only three terminals, but the wire positions are the same.
6. The shutter resistor has the variations shown in Fig.16, Fig.16 shows the wires which connect to the amplifier unit.

**OTHER COMMENTS:**

1. If the wind lever is forced, the lug on the underside of the plastic disc (next to top cover, under wind lever) may break. The broken lug often falls into the wind mechanism and jams the shutter gears. The new-style disc is made of less brittle plastic. Part #55B 120740.
2. If the shutter doesn't wind fully—or if it takes a hard push on the wind lever to complete the cocking stroke—check the slot in the wind-shaft coupler (the cam under the wind lever which fits over the wind shaft). Wear may have expanded the slot in the wind-shaft coupler, allowing too much play in the wind lever. Part #85B120750.
3. Grease or dirt can cause the f-value ring to bind. If the f-value ring does not return freely, remove the lens-mounting ring to clean the parts.
4. The adjustment for the first-curtain brake involves adding or removing washers under the compression-type spring (inside the plastic cylinder, Fig. 6). Adding washers increases the braking action. However, you can usually correct curtain bounce by replacing the tension-type spring attached to the brake lever, Fig.3. Part #50B 99660.
5. You can remove both the take-up spool and the sprocket after taking out the lower mechanism plate, wind side. It's not necessary to remove the wind shaft. Take-up spool — #37A 102700, Sprocket—#348 93220.

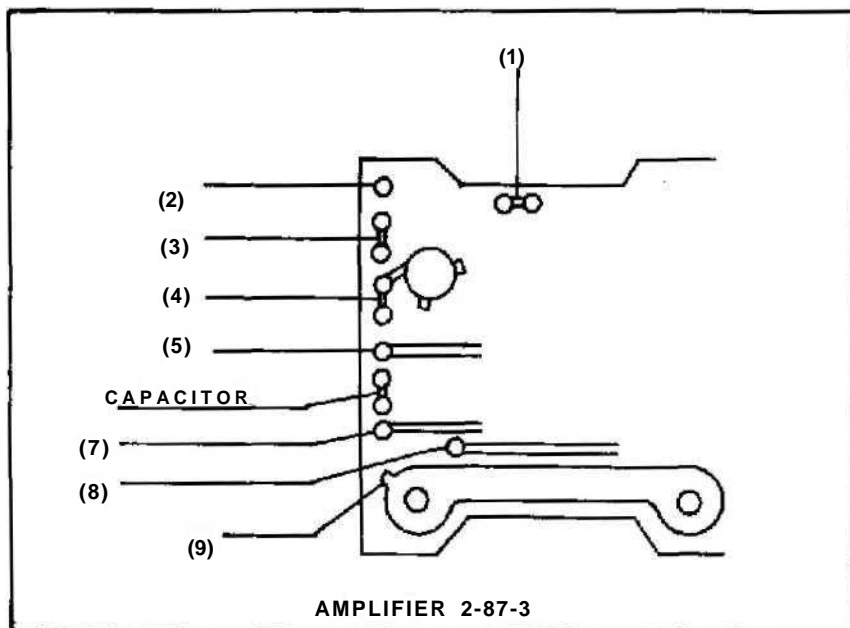

**FIGURE 13**

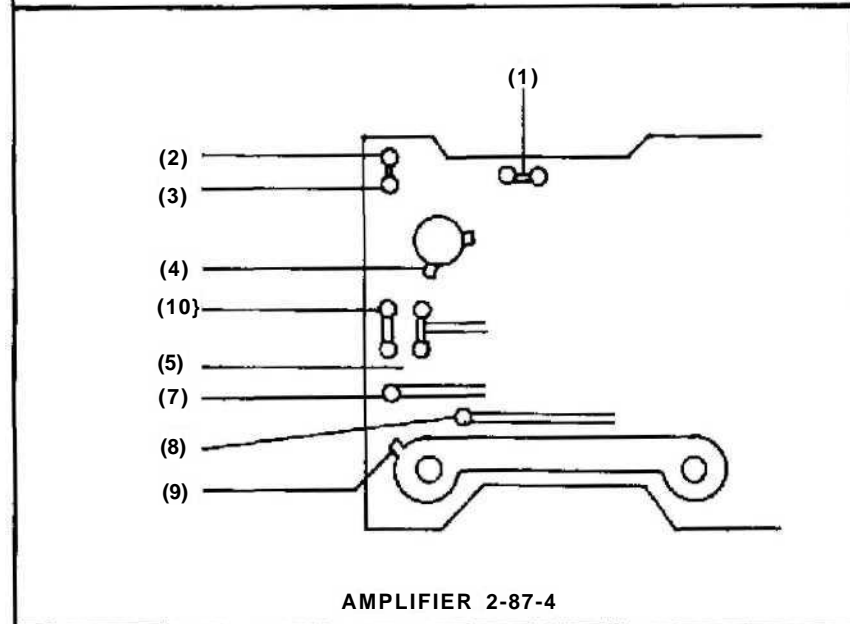

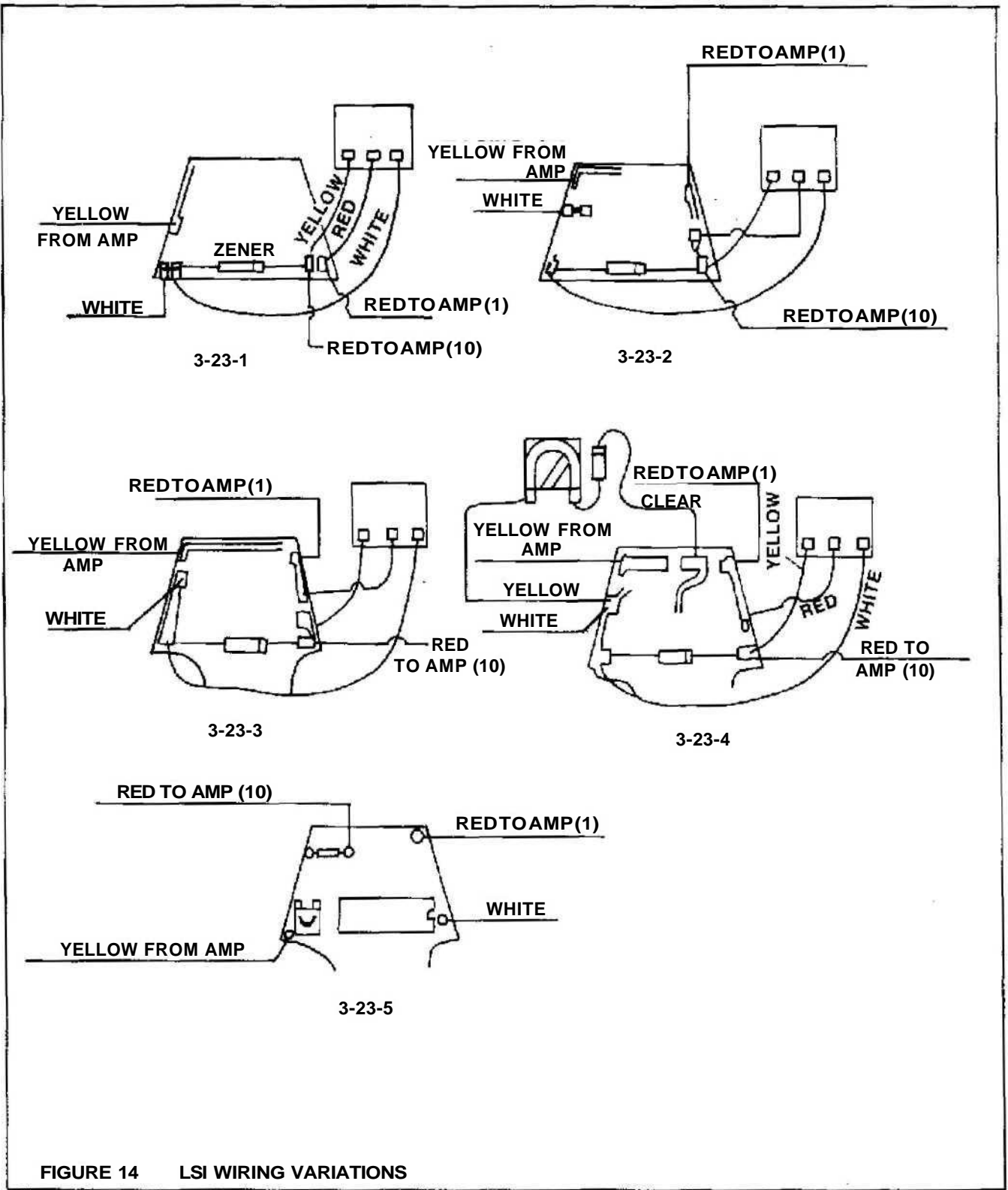

FIGURE 14 LSI WIRING VARIATIONS

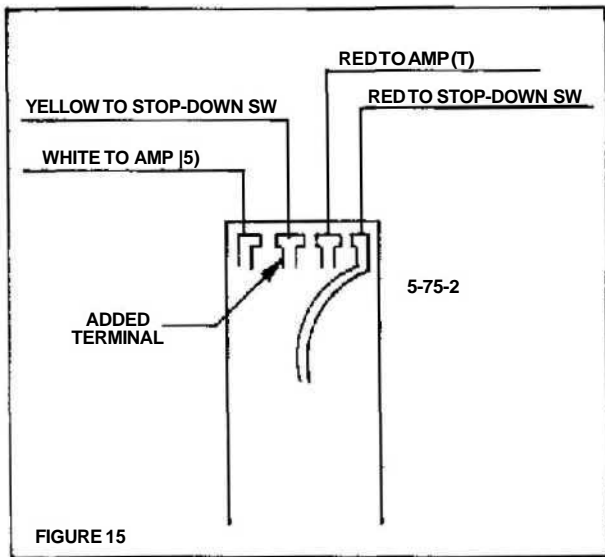

FIGURE 15

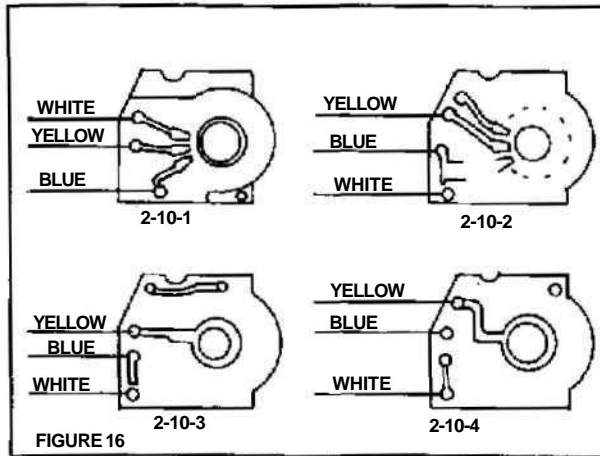

FIGURE 16

CAMERA BODY SERIALNUMBERS												
2-87 Amplifier	LSI 3-23					SHUTTER RESISTOR 2-10				APERTURE RESISTOR 5-7S		
	3050001 3-23-1	801XXXX 3-23-2	104XXXX 3-23-3	305XXXX 3-23-*	312XXXX 3-23-5	8050001 2-10-1	811XXX 2-10-2	2-10-3	311XXXX 2-10-4	8050001 5-75-1	809XXXX 5-75-2	311XXXX 5-75-3
8050001 2-87-2 (K1A-3)	O	O.K.	O.K.	O.K.	O.K.	O	X	X	X	O	X	X
807XXXX 2-87-2 (K1A-3)	O	O	O.K.	O.K.	O.K.	O	X	X	X	X	O	O.K.
809XXXX 2-87-3 (K1A-4)	O.K.	O	O.K.	O.K.	O.K.	O	X	X	X	X	O	O.K.
906XXXX 2-87-4 (K1A-5)	O.K.	O	O	O.K.	O.K.	X	O	O	O.K.	X	O	O.K.
204XXXX 2-87-5 (K1A-6)	O.K.	O.K.	O	O.K.	O.K.	X	O.K.	O	O.K.	X	O	O.K.
305XXXX 2-87-6 (K1A-7)	X	X	X	O	O.K.	X	O.K.	O	O	X	O	O
312XXXX 2-97-7 (K1A-8)	X	X	X	O.K.	O	X	O.K.	O.K.	O	X	O.K.	O

KEY: O-ORIGINAL COMBINATION  
X-MAY NOT BE COMBINED  
O.K.-O.K. TO CONTINUE

FIGURE 17