

COPAL SQUARE S

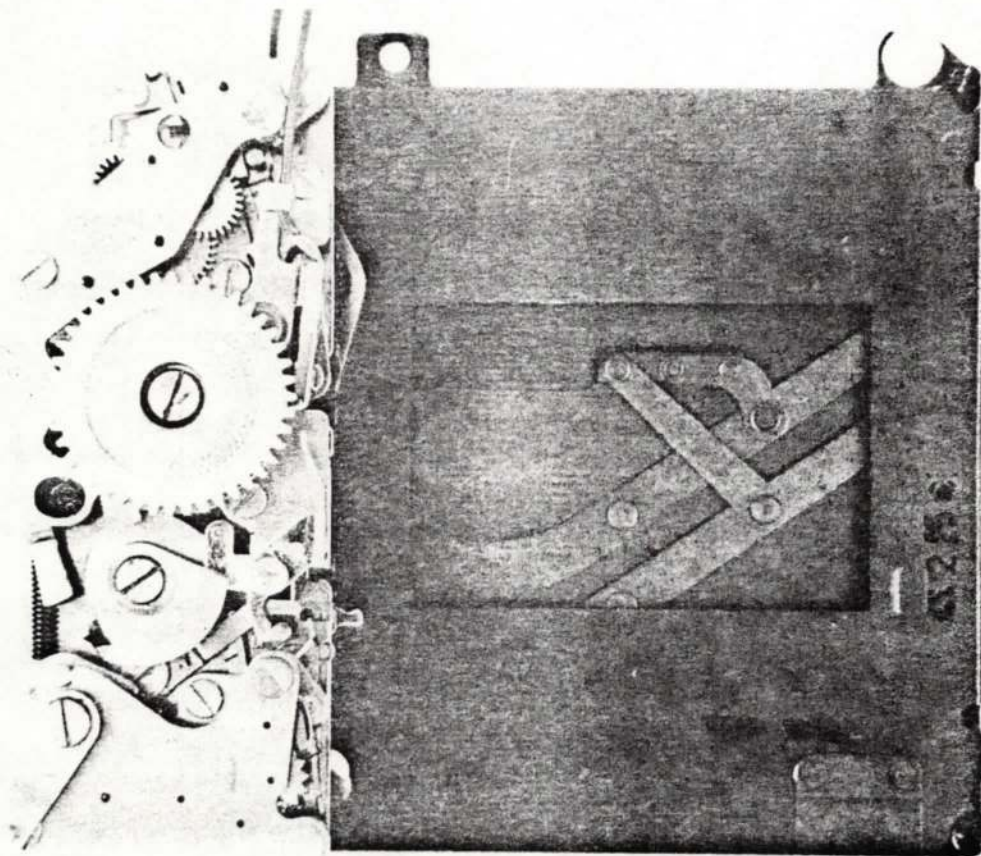

Reprinted September 1976

© Copyright 1970

NATIONAL CAMERA
TECHNICAL TRAINING DIVISION

2000 W. Union Avenue • Englewood, Colorado 80110



U.S.A.

ALL RIGHTS RESERVED

SHUTTER SPEED
SETTING RING

TRANSFER GEARS
TO SHUTTER SPEED
SETTING GEAR IN
SHUTTER

DELAYED-ACTION
COCKING LEVER
(TO DELAYED-ACTION
COCKING ARM IN
SHUTTER)

1

CAMERA USING THE COPAL SQUARE S SHUTTER

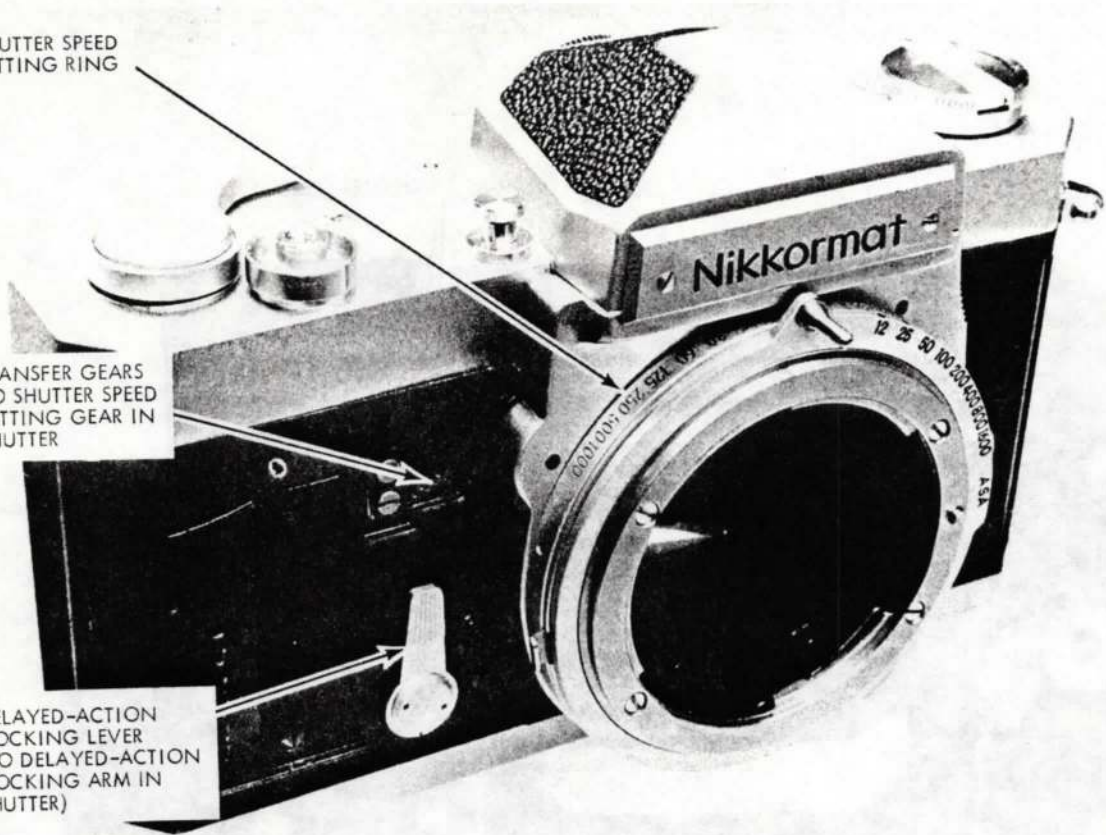

TRANSFER GEARS TO SHUTTER SPEED SETTING
GEAR

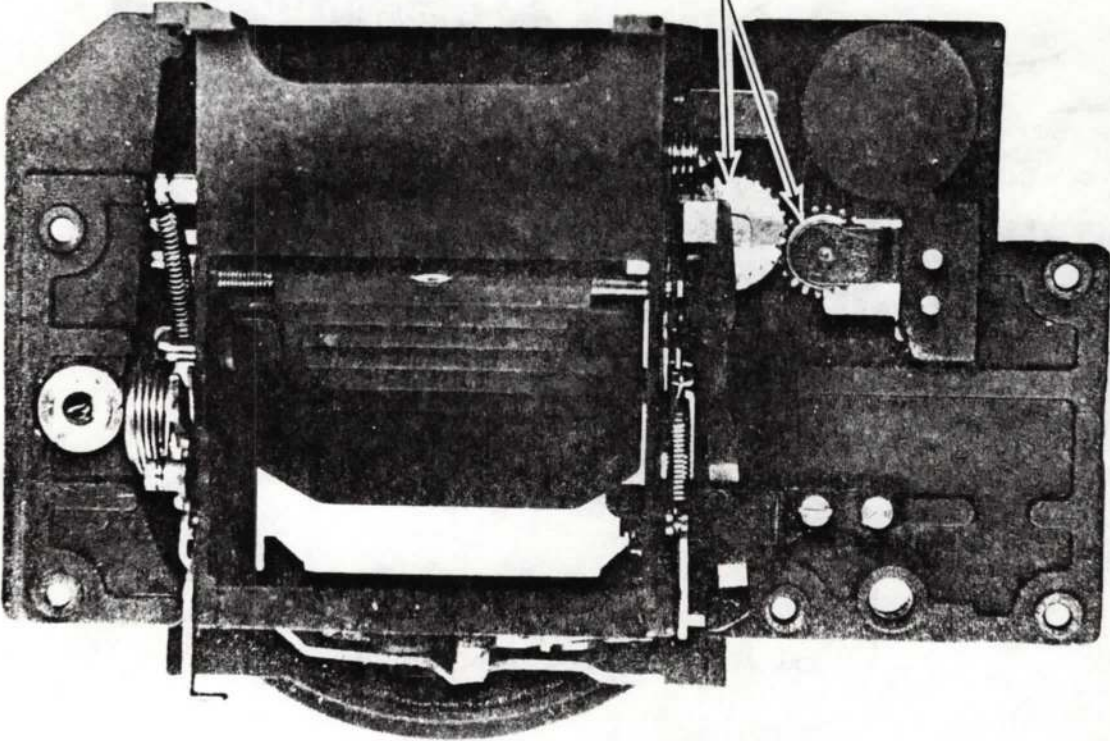

2

INSIDE OF CAMERA FRONT PLATE ASSEMBLY

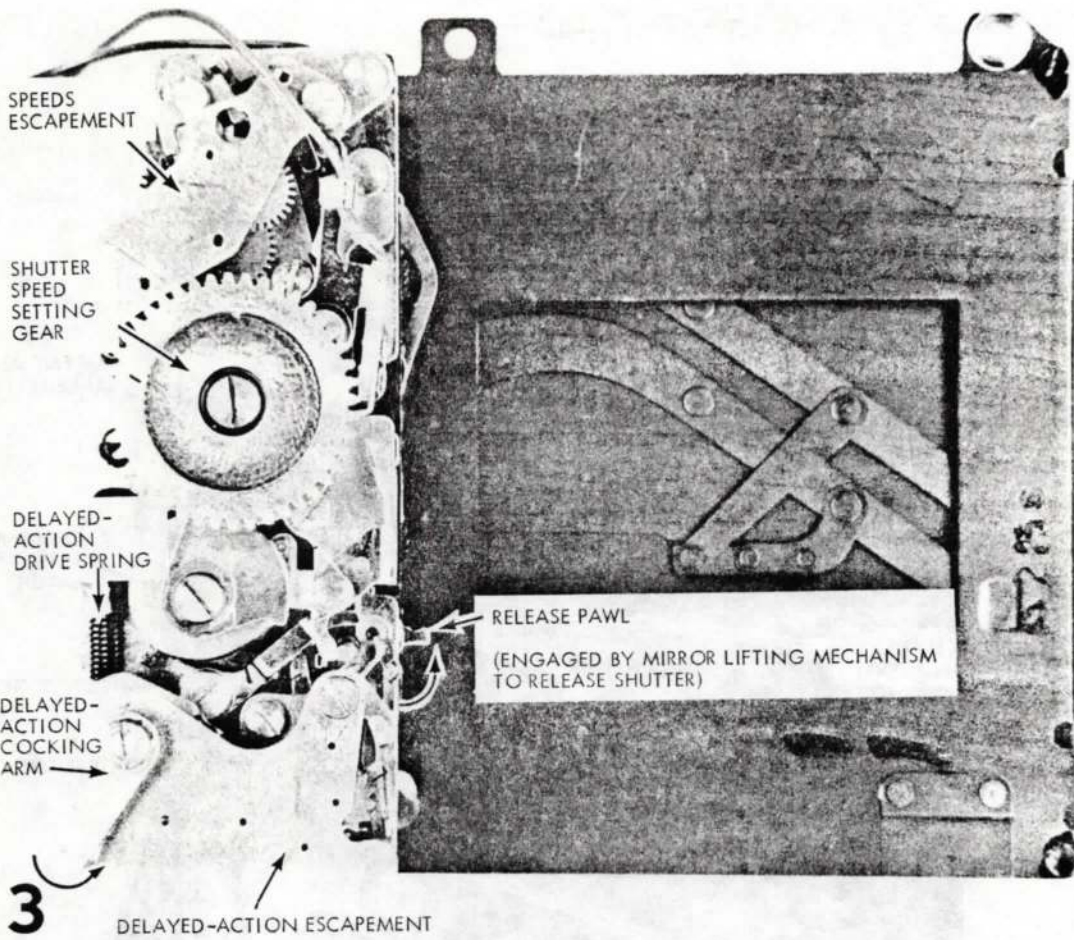

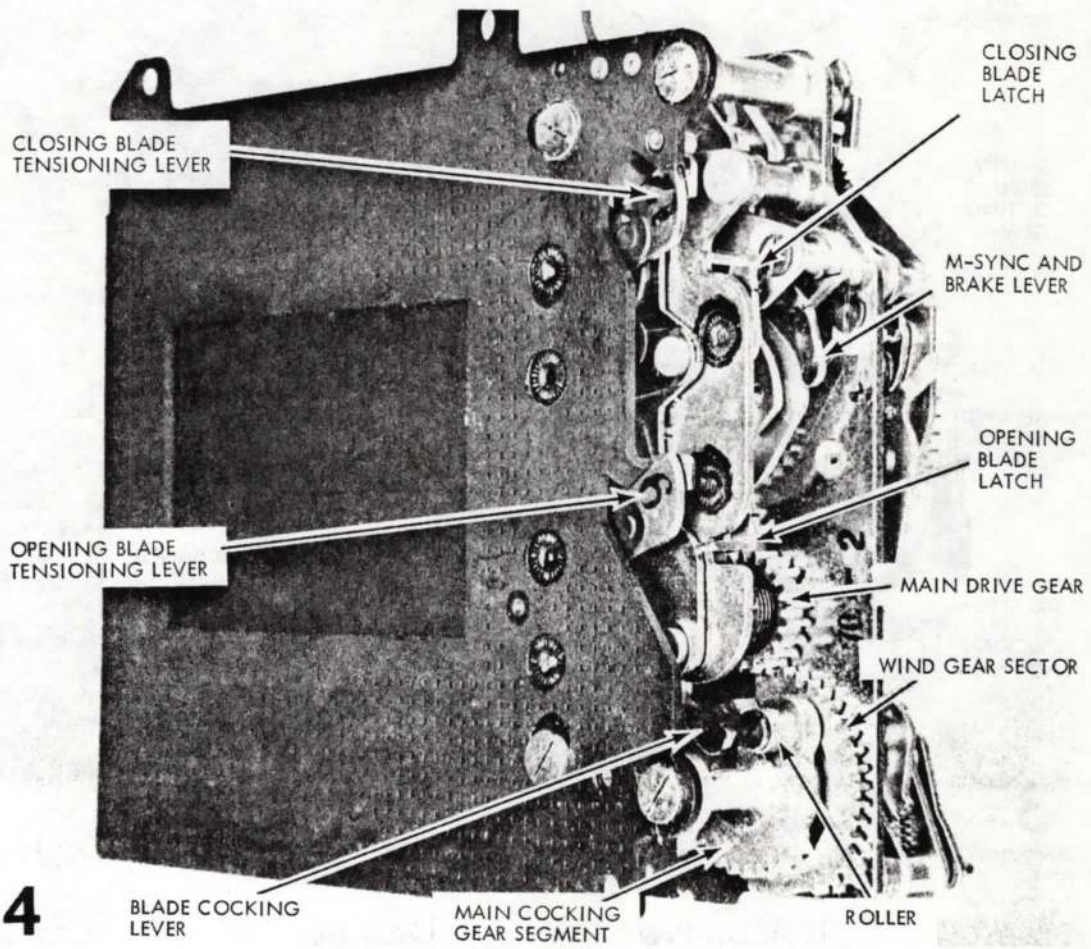

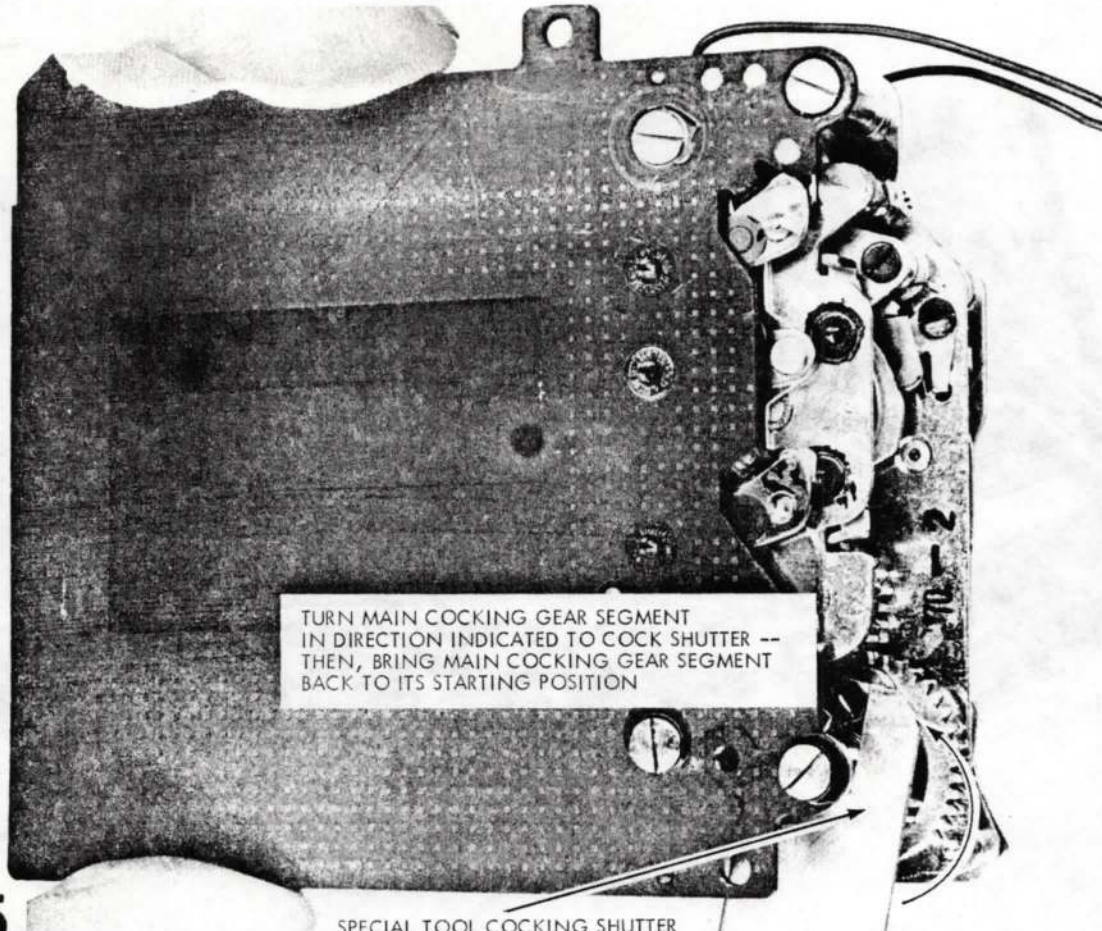

TURN MAIN COCKING GEAR SEGMENT
IN DIRECTION INDICATED TO COCK SHUTTER --
THEN, BRING MAIN COCKING GEAR SEGMENT
BACK TO ITS STARTING POSITION

5

SPECIAL TOOL COCKING SHUTTER

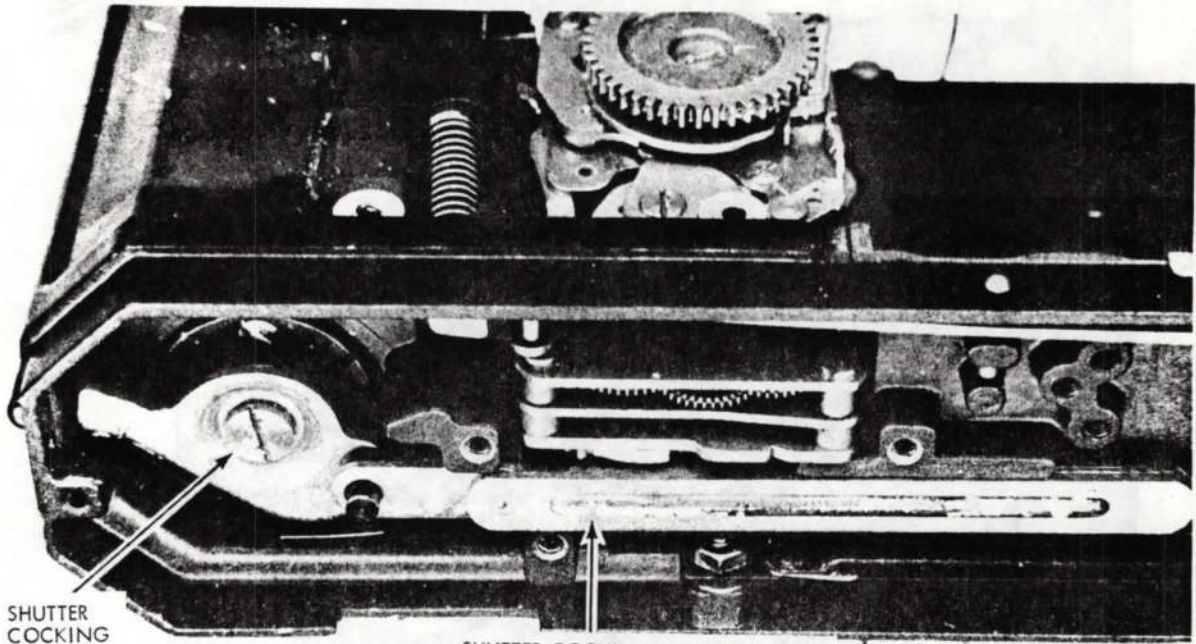

SHUTTER
COCKING
CAM

SHUTTER COCKING RACK ENGAGES
MAIN COCKING GEAR SEGMENT

6

CAMERA MECHANISM THAT COCKS SHUTTER

SHUTTER COCKED

CLOSING BLADE
HELD HERE

OPENING BLADE
HELD HERE

7

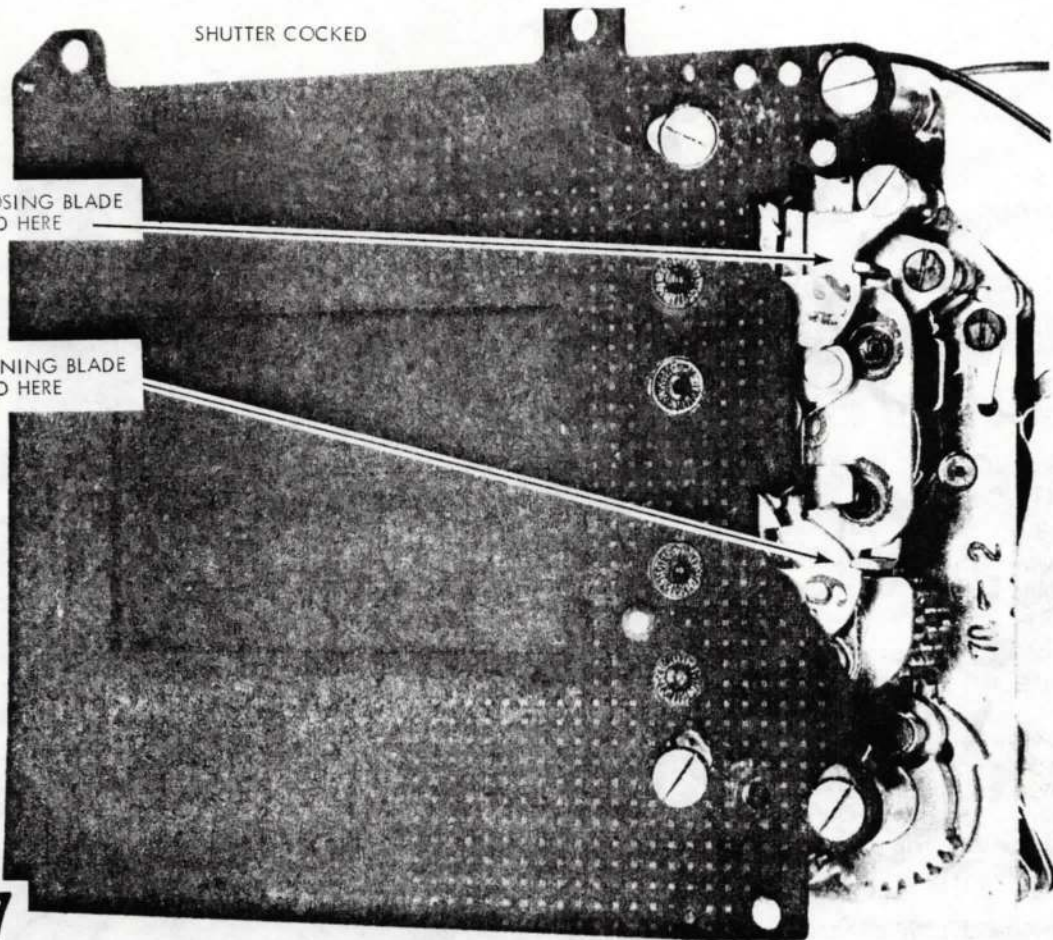

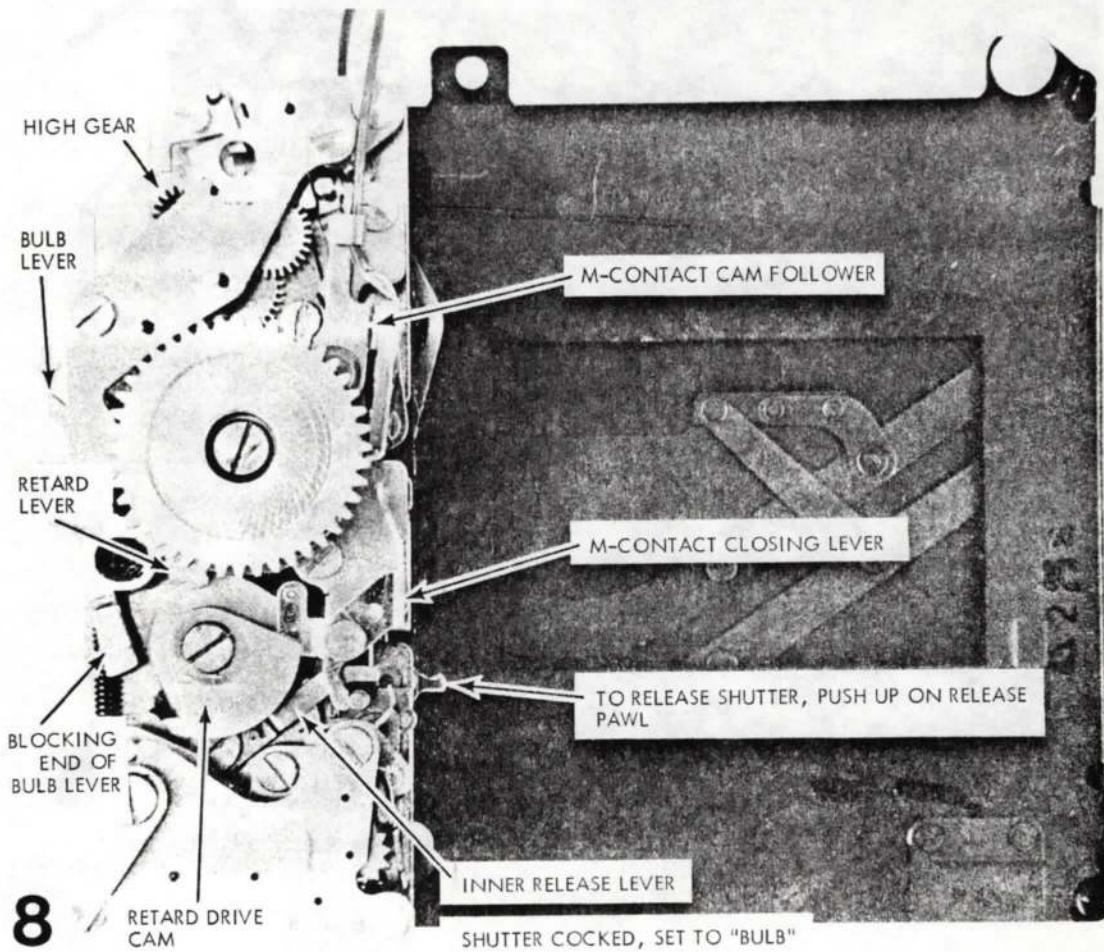

8

RETARD DRIVE CAM

HIGH GEAR

BULB LEVER

RETARD LEVER

BLOCKING END OF BULB LEVER

M-CONTACT CAM FOLLOWER

M-CONTACT CLOSING LEVER

TO RELEASE SHUTTER, PUSH UP ON RELEASE PAWL

INNER RELEASE LEVER

SHUTTER COCKED, SET TO "BULB"

HOLD THIS END OF BULB
LEVER DOWN TO SIMULATE
"BULB" ACTION

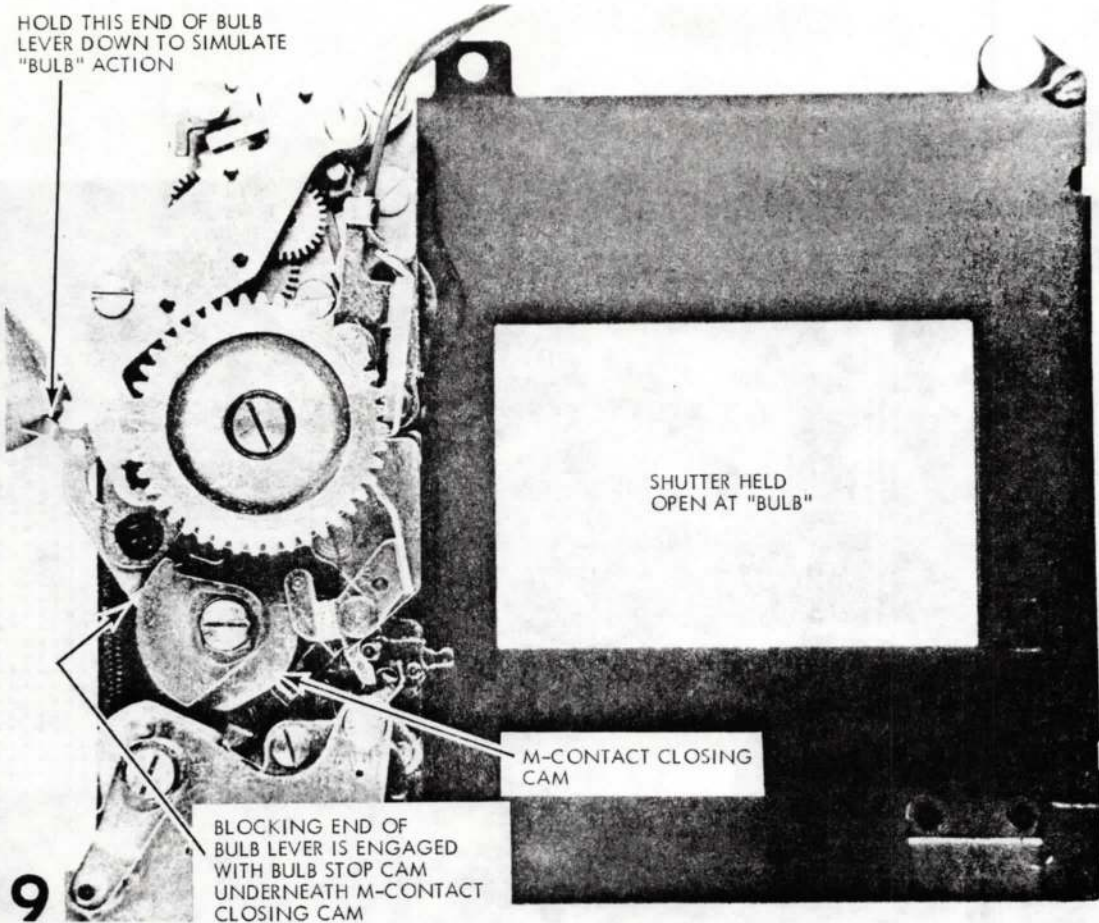

SHUTTER HELD
OPEN AT "BULB"

M-CONTACT CLOSING
CAM

BLOCKING END OF
BULB LEVER IS ENGAGED
WITH BULB STOP CAM
UNDERNEATH M-CONTACT
CLOSING CAM

9

CAMERA MECHANISM MOVING "BULB" LEVER

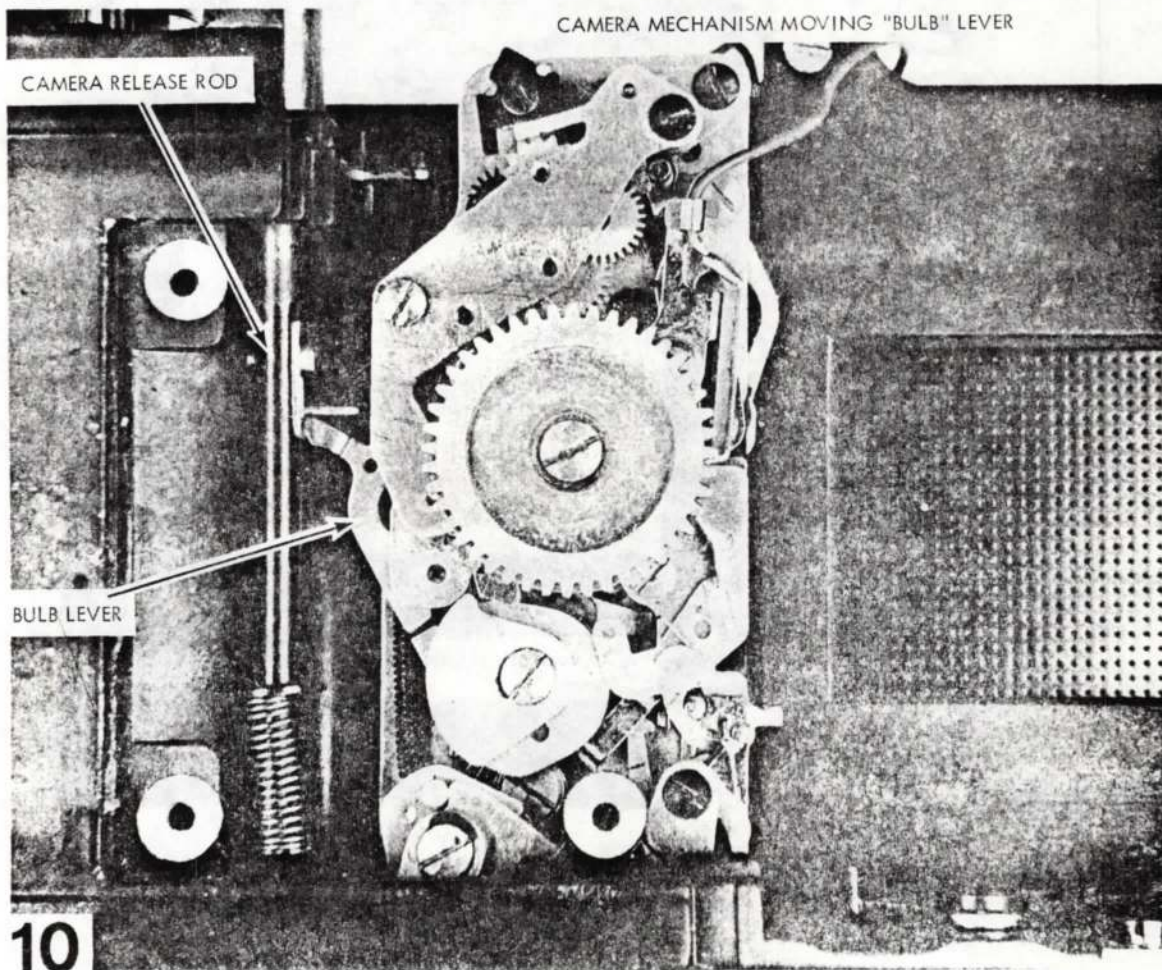

SHUTTER SPEED CYCLE

VARYING AMOUNTS OF RETARD STROKE AT
 1 SECOND THROUGH 1/125 SECOND -- NO
 RETARD AT 1/250 SECOND THROUGH 1/1000 SECOND.

1 SEC THROUGH 1/30 SEC -- FULL PALLET
 1 SEC THROUGH 1/4 SEC -- STEPPED-UP GEARING
 1/8 SEC THROUGH 1/125 SEC -- DIRECT GEARING

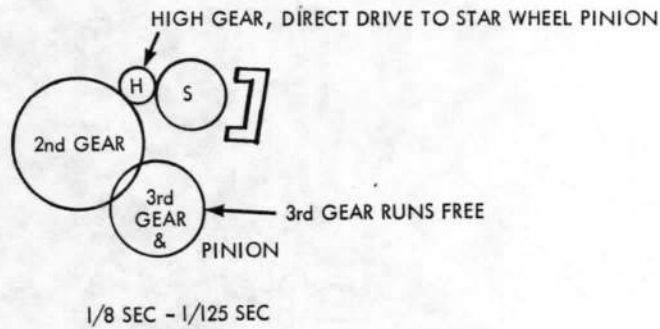
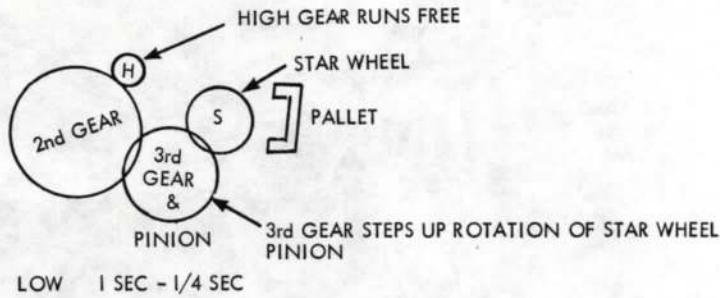

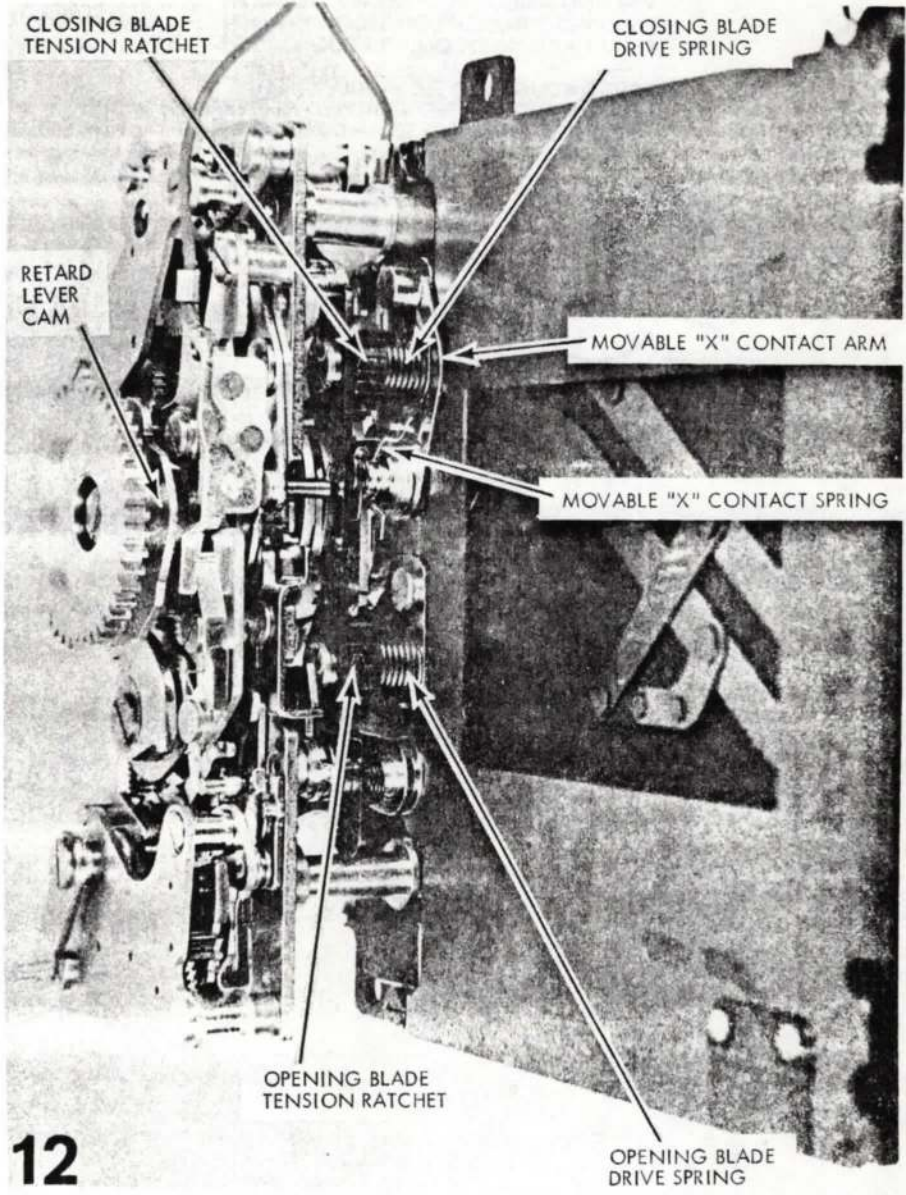

"X" SYNC CONTACTS

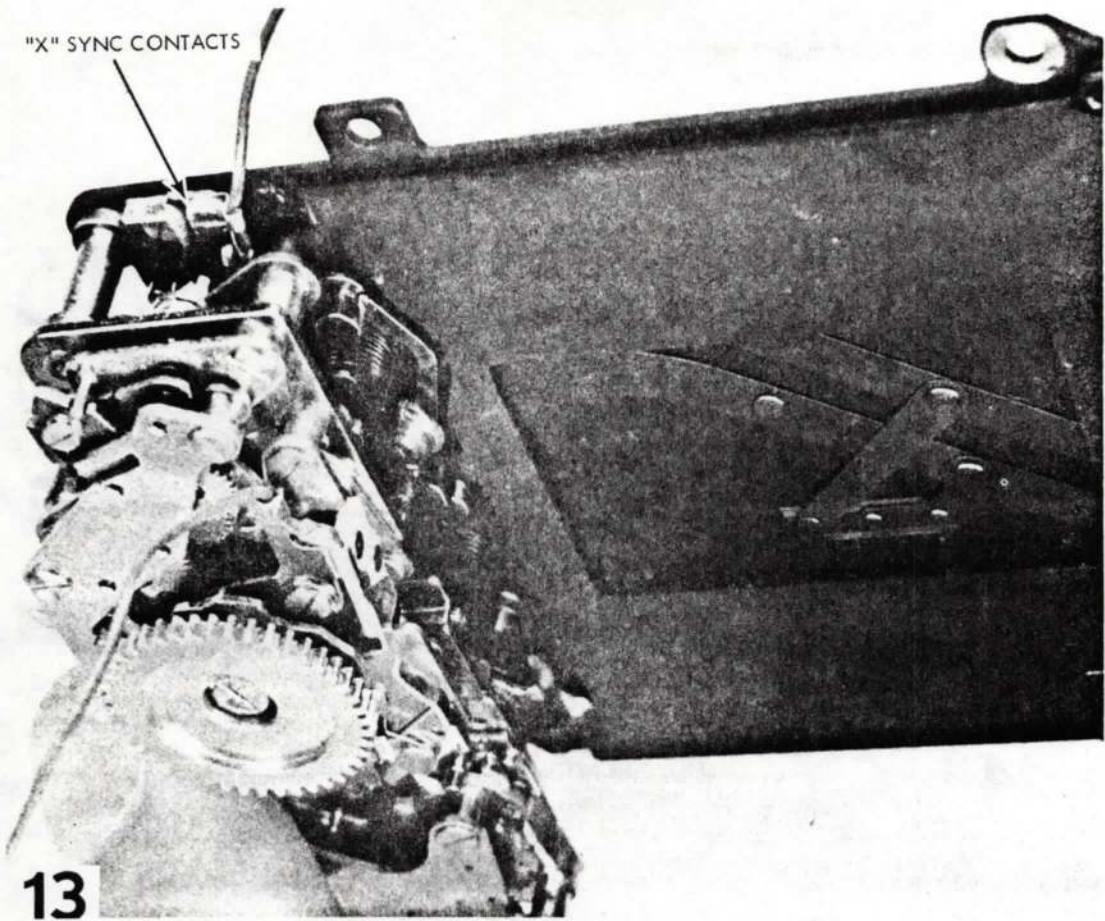

13

TO REMOVE DELAYED-ACTION ESCAPEMENT:

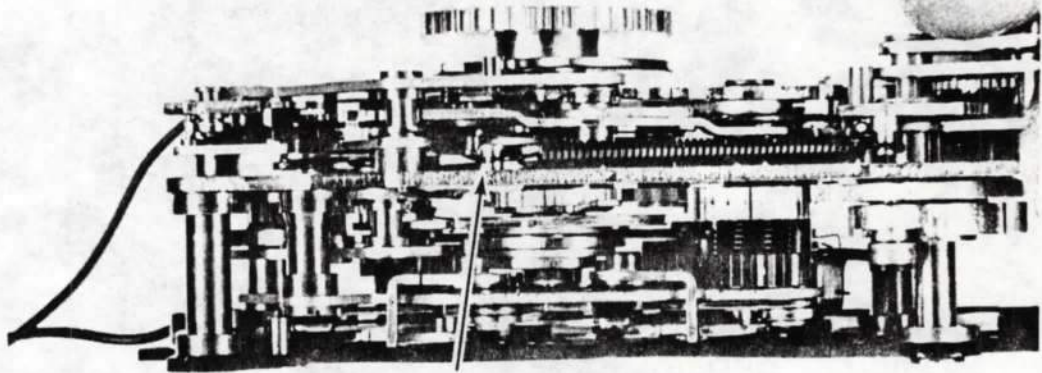

1 DISCONNECT END OF DELAYED-ACTION DRIVE
DRIVE SPRING FROM POST ON MECHANISM
PLATE

2 REMOVE DELAYED-ACTION DRIVE SPRING

(con't figure 15)

14

3 PARTIALLY COCK DELAYED-ACTION MECHANISM

4 REMOVE THREE
DELAYED-ACTION
RETAINING SCREWS

DELAYED-ACTION CATCH LEVER

STAR WHEEL BLOCKING LEVER

5 LIFT OUT DELAYED-ACTION ESCAPEMENT

NOTE POSITION
OF INNER RELEASE
LEVER SPRING

CAUTION: THERE ARE SPACERS UNDER THE
DELAYED-ACTION ESCAPEMENT AT THE BRASS
SCREW POSITIONS

15

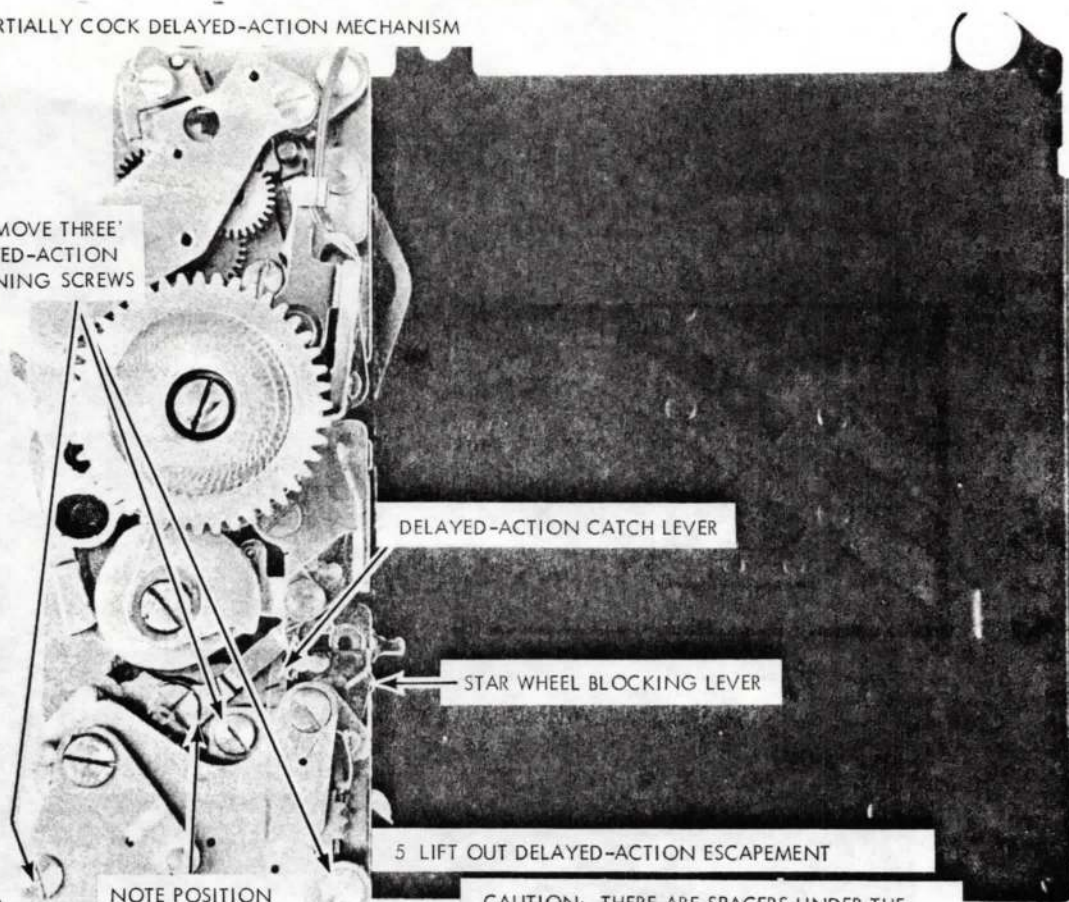

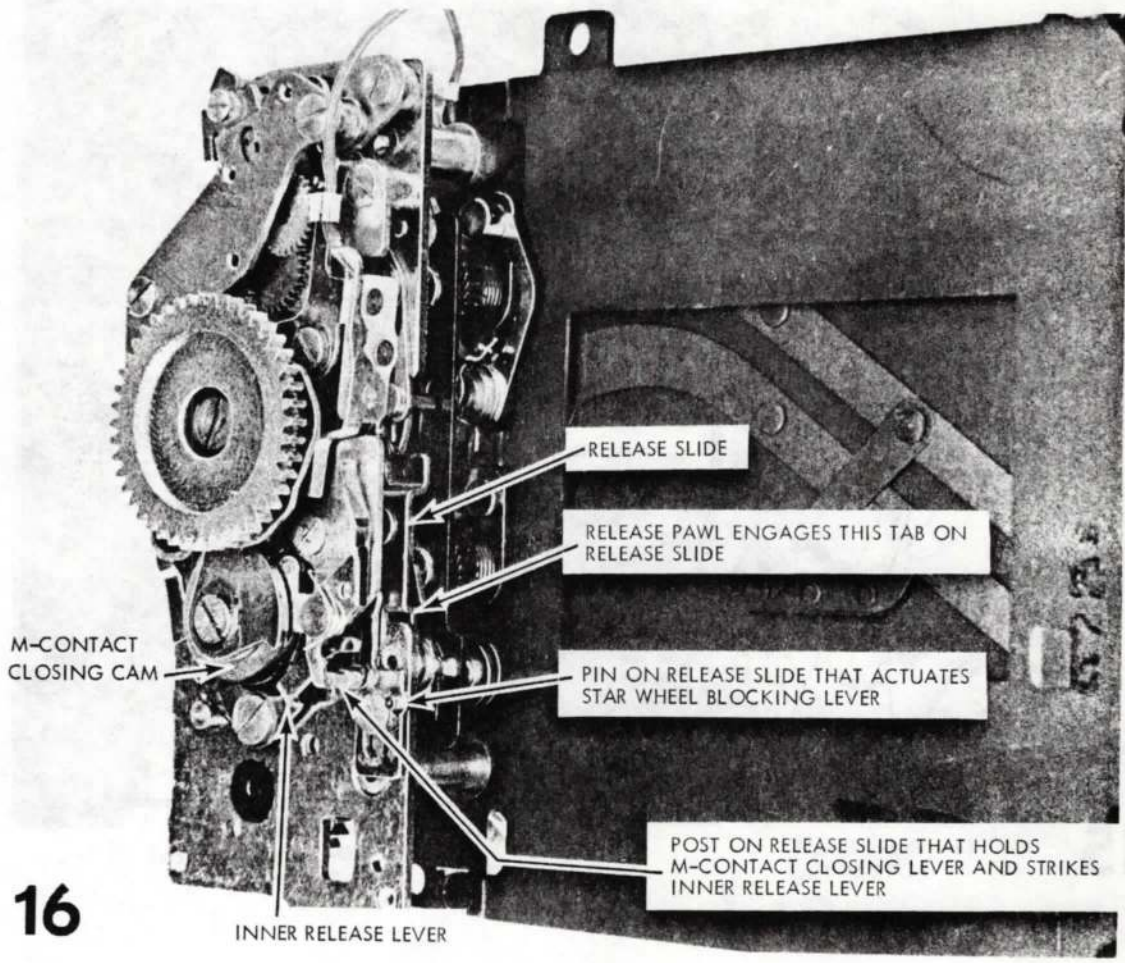

16

INNER RELEASE LEVER

M-CONTACT
CLOSING CAM

RELEASE SLIDE

RELEASE PAWL ENGAGES THIS TAB ON
RELEASE SLIDE

PIN ON RELEASE SLIDE THAT ACTUATES
STAR WHEEL BLOCKING LEVER

POST ON RELEASE SLIDE THAT HOLDS
M-CONTACT CLOSING LEVER AND STRIKES
INNER RELEASE LEVER

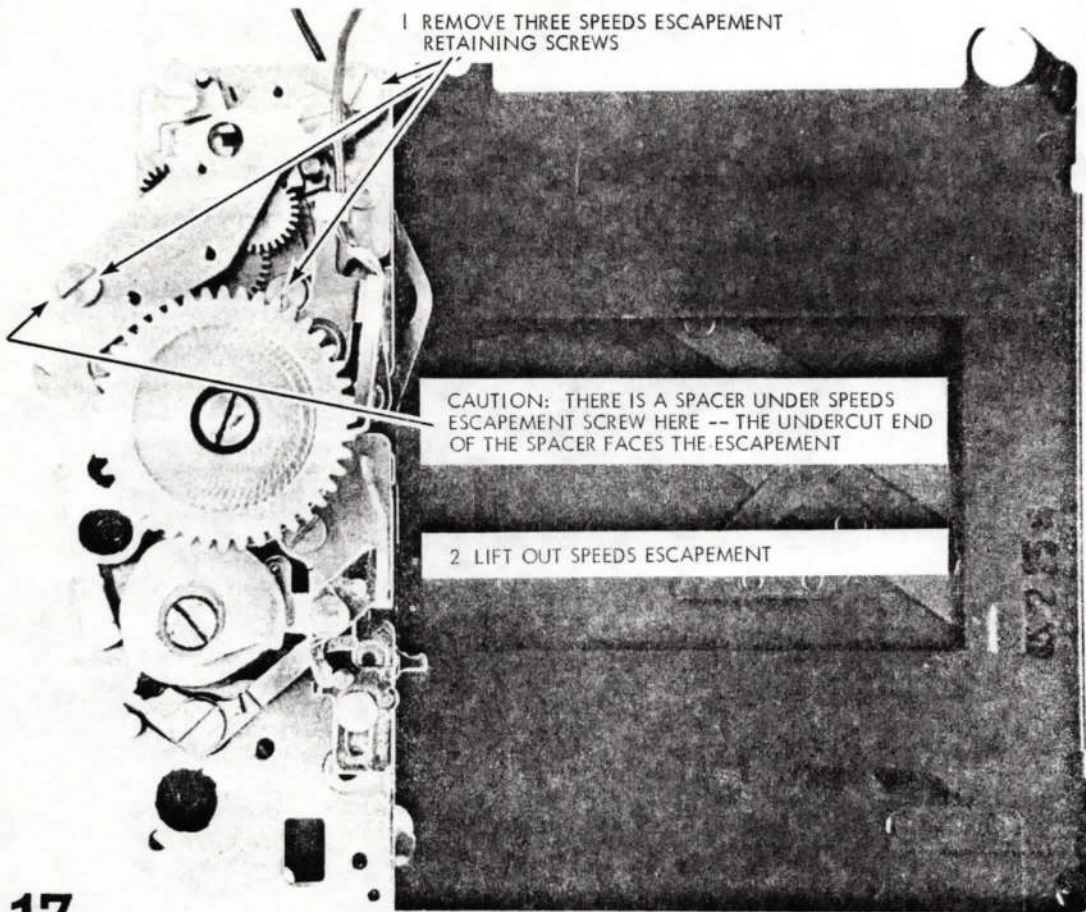

1 REMOVE THREE SPEEDS ESCAPEMENT
RETAINING SCREWS

CAUTION: THERE IS A SPACER UNDER SPEEDS
ESCAPEMENT SCREW HERE -- THE UNDERCUT END
OF THE SPACER FACES THE ESCAPEMENT

2 LIFT OUT SPEEDS ESCAPEMENT

UNDERSIDE OF SPEEDS ESCAPEMENT

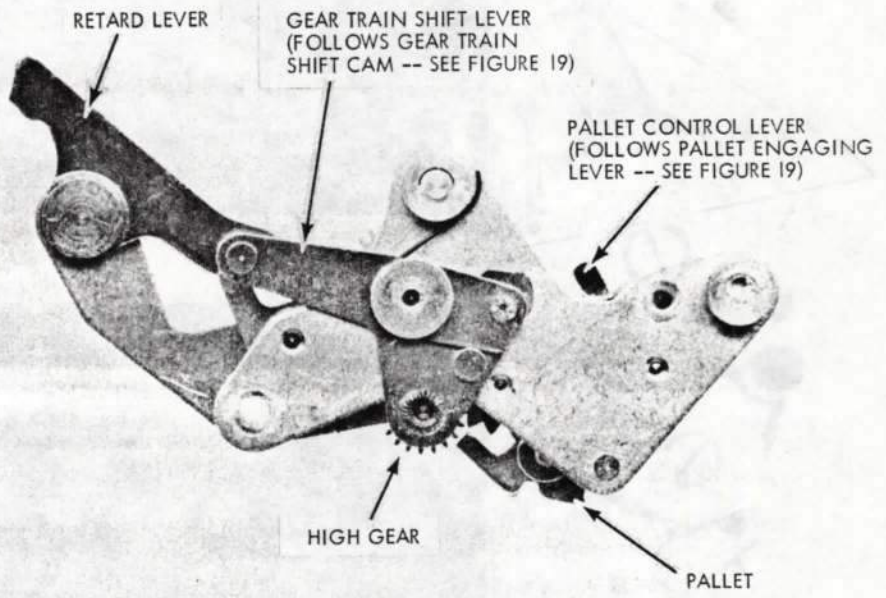

18

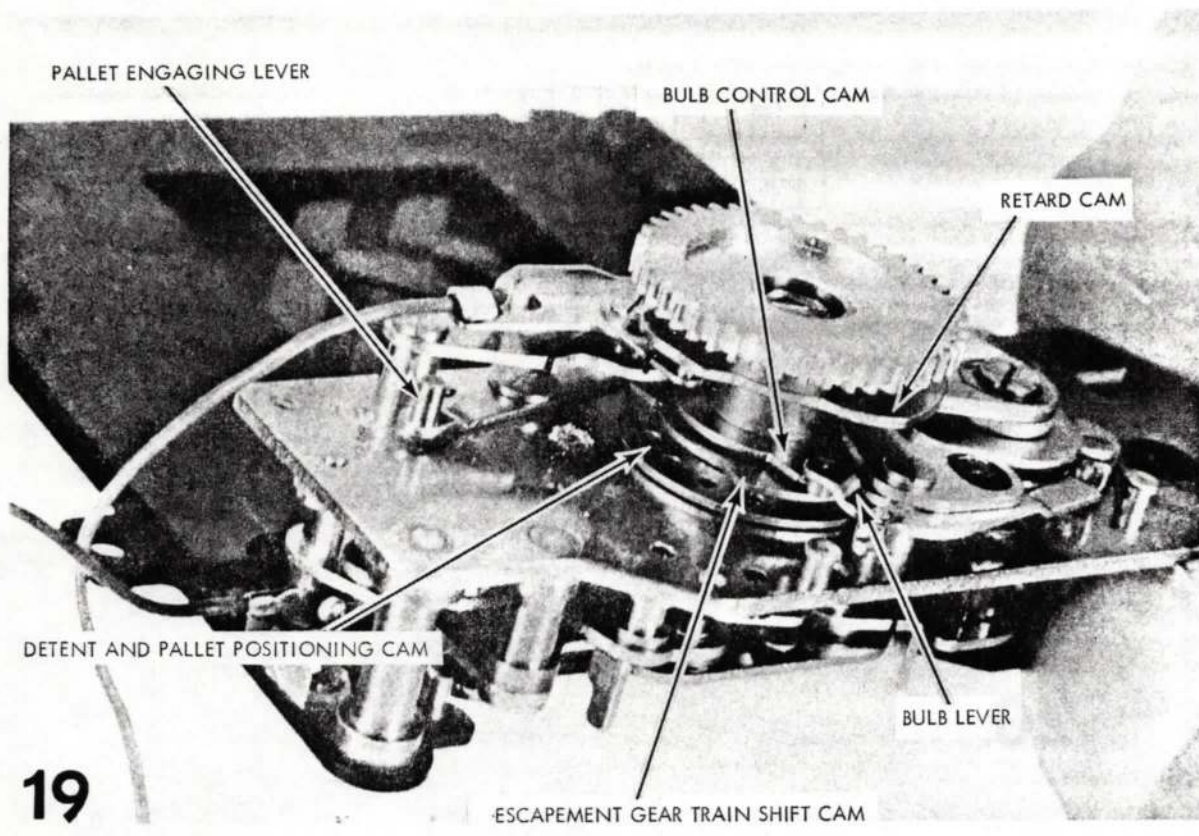

19

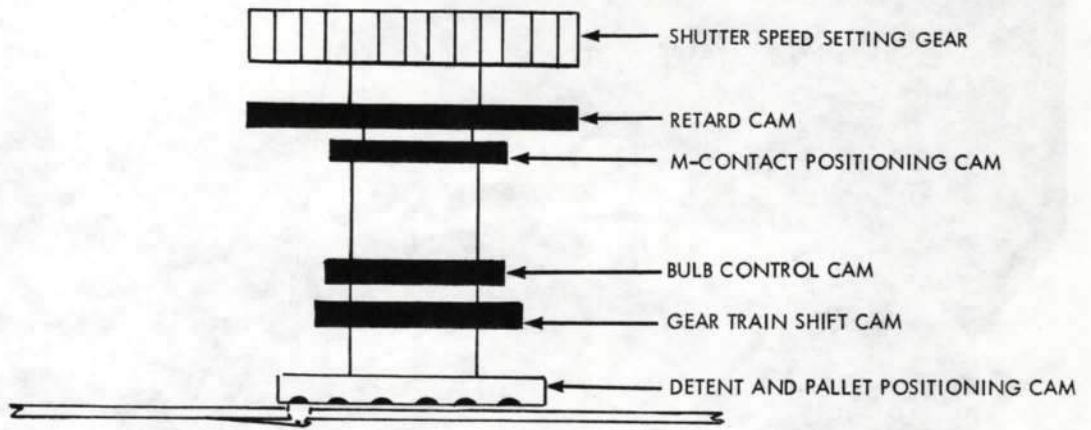

GRAPHIC SKETCH OF SPEED CONTROL CAM STACK

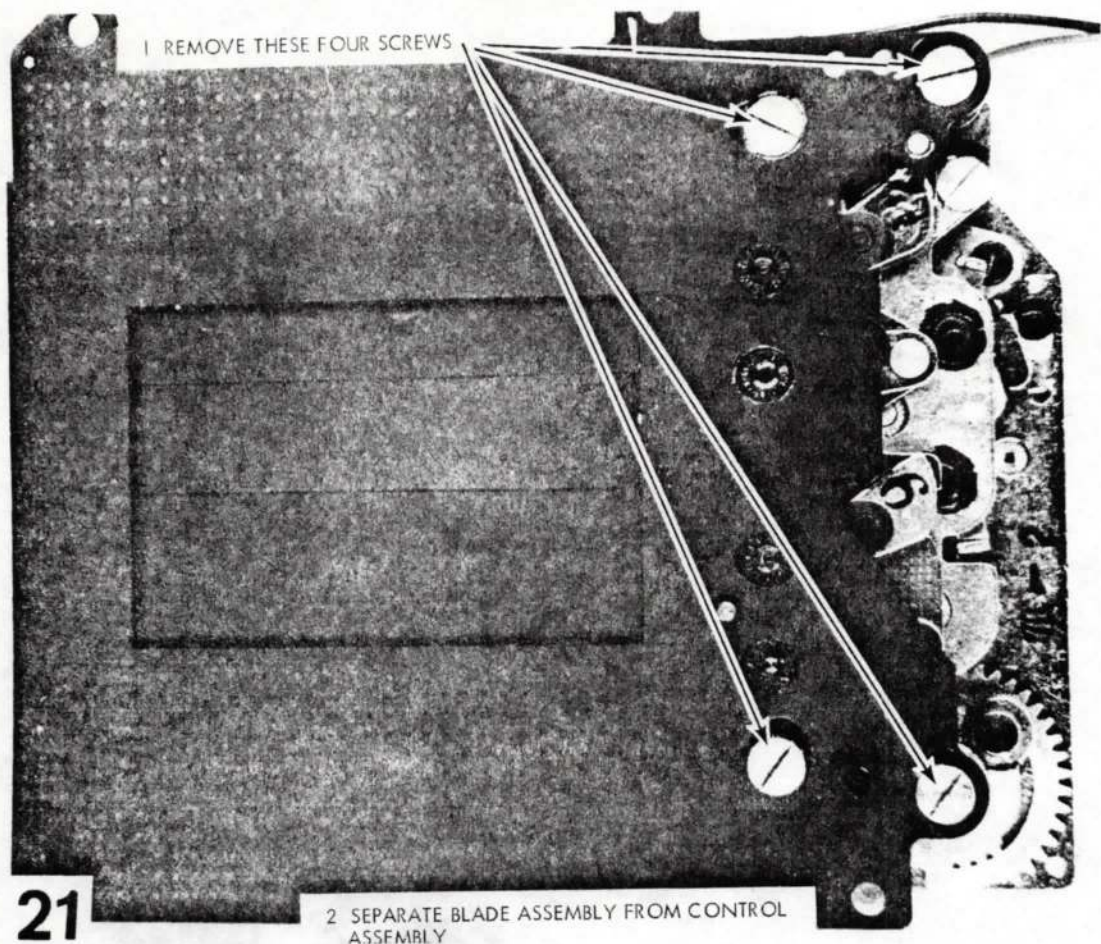

1 REMOVE THESE FOUR SCREWS

2 SEPARATE BLADE ASSEMBLY FROM CONTROL ASSEMBLY

21

LIFT OFF SPACER ON BACK OF CONTROL ASSEMBLY

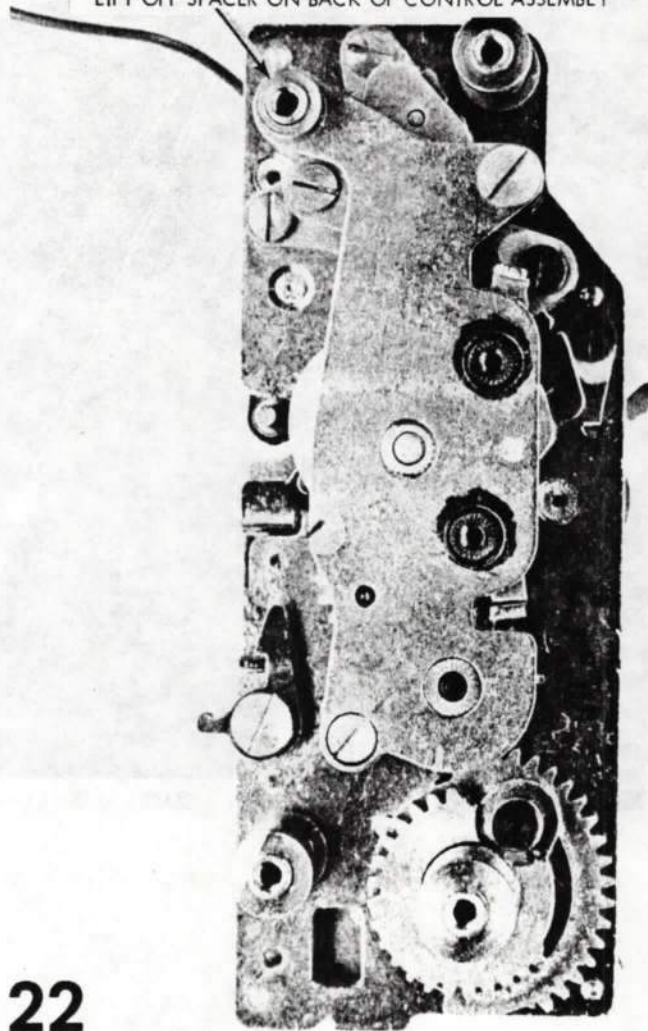

22

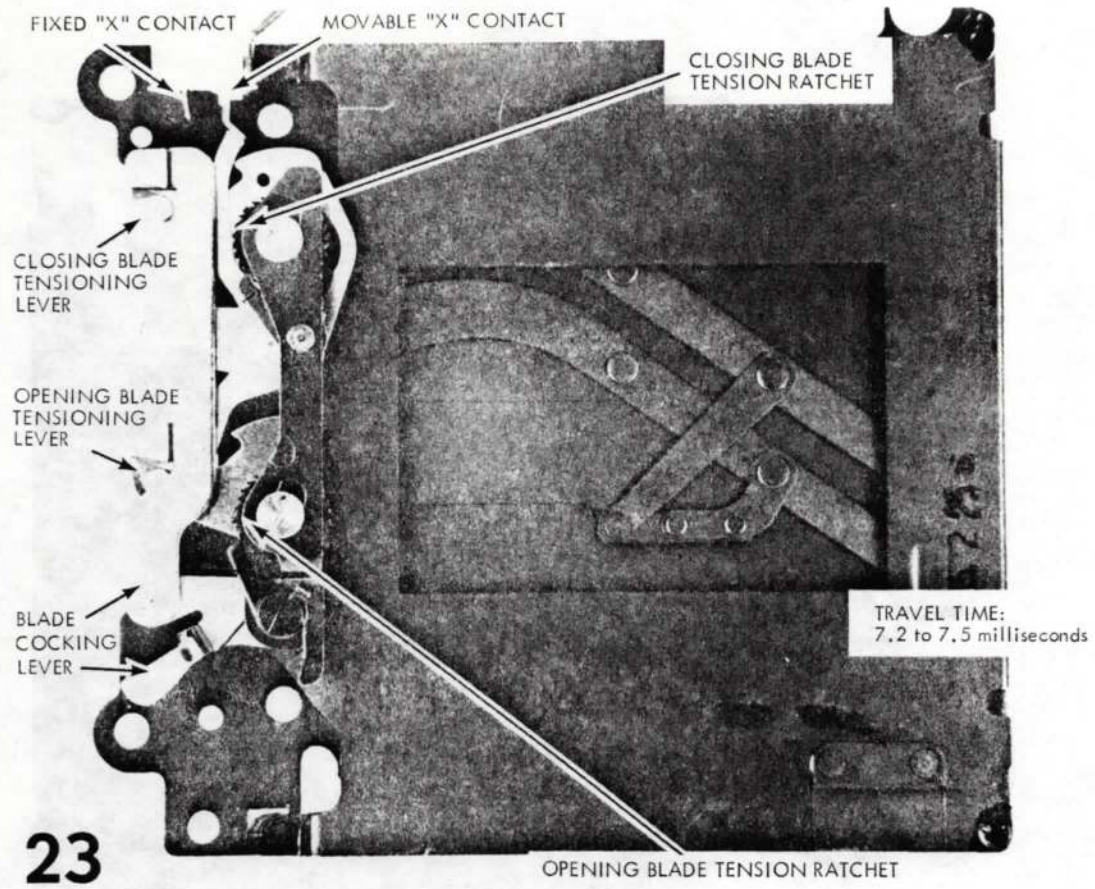

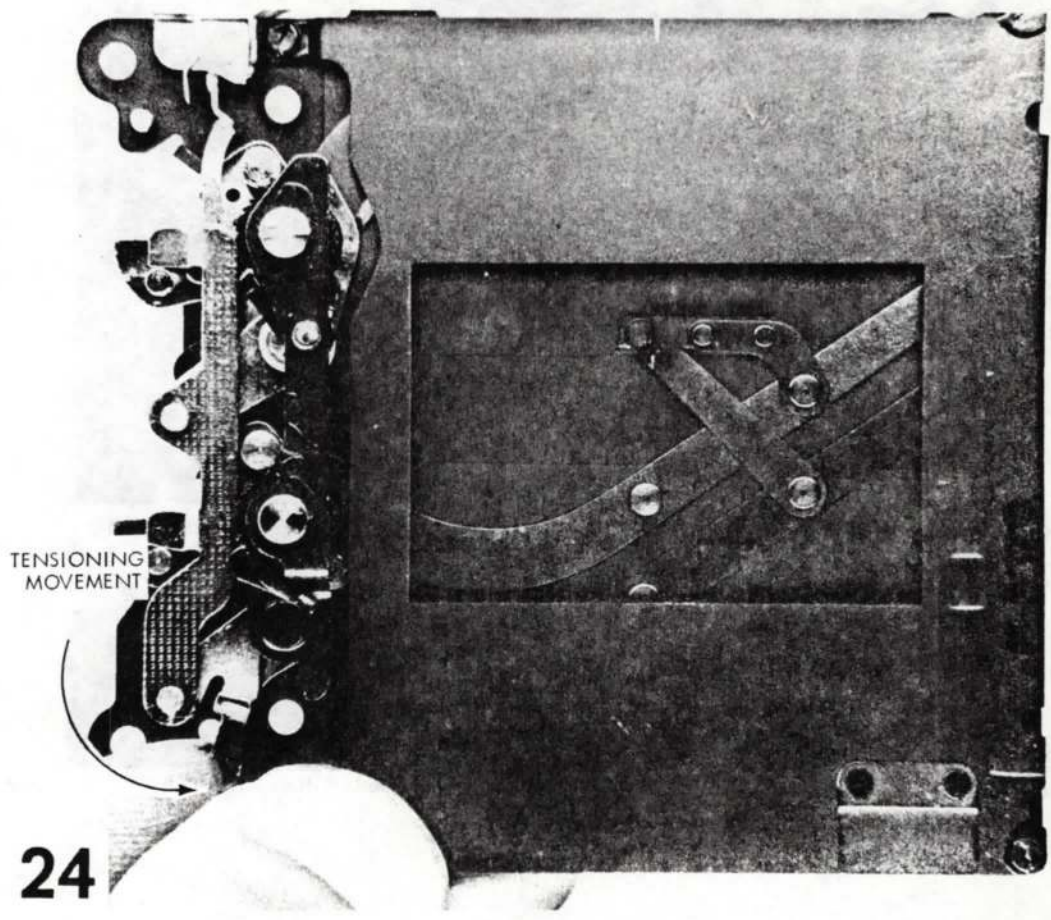

TENSIONING
MOVEMENT

24

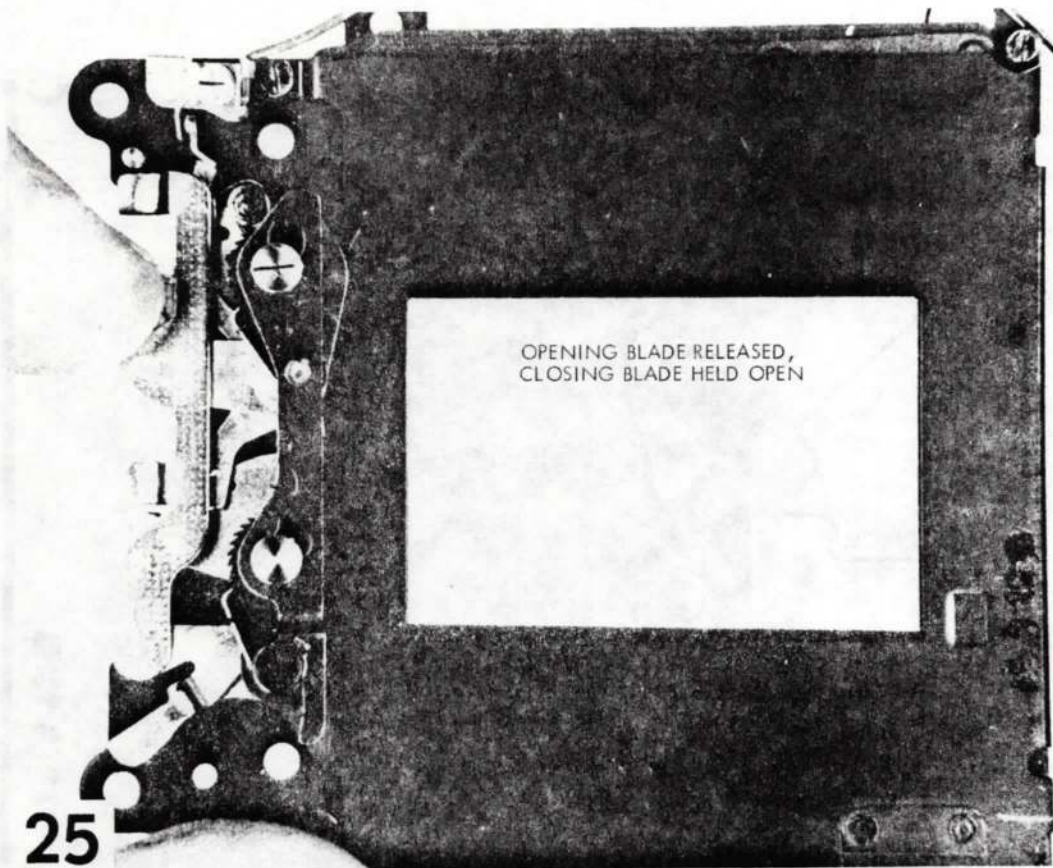

OPENING BLADE RELEASED,
CLOSING BLADE HELD OPEN

25

DISCONNECT MOVABLE "X"
CONTACT SPRING FROM TAB
ON BLADE COVER PLATE

(EASIEST FROM
"BACK" SIDE)

26

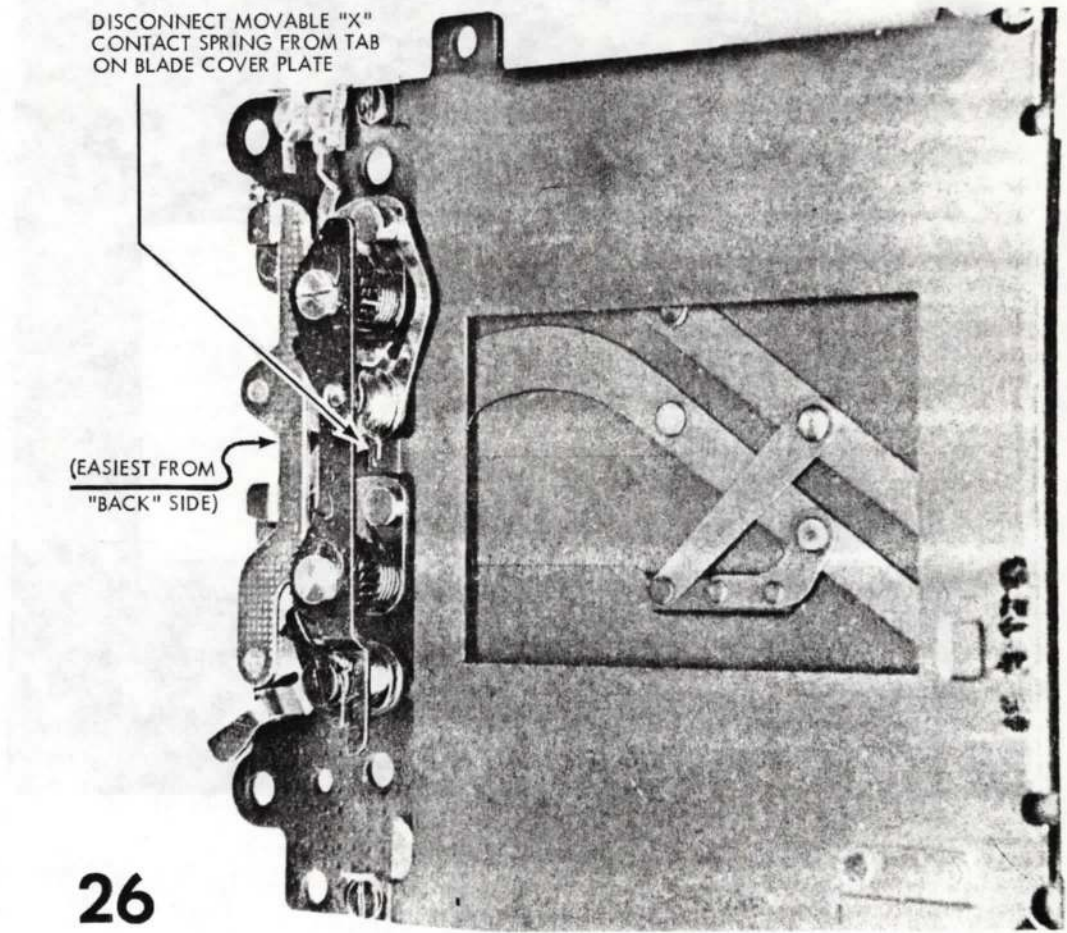

REMOVE FOUR SCREWS
AND LIFT OFF BLADE
COVER PLATE

CAUTION: SPACERS UNDER THESE CORNERS
OF BLADE COVER PLATE

27

CAUTION: OBSERVE POSITION OF DAMPING
SPRING UNDER THIS SCREW

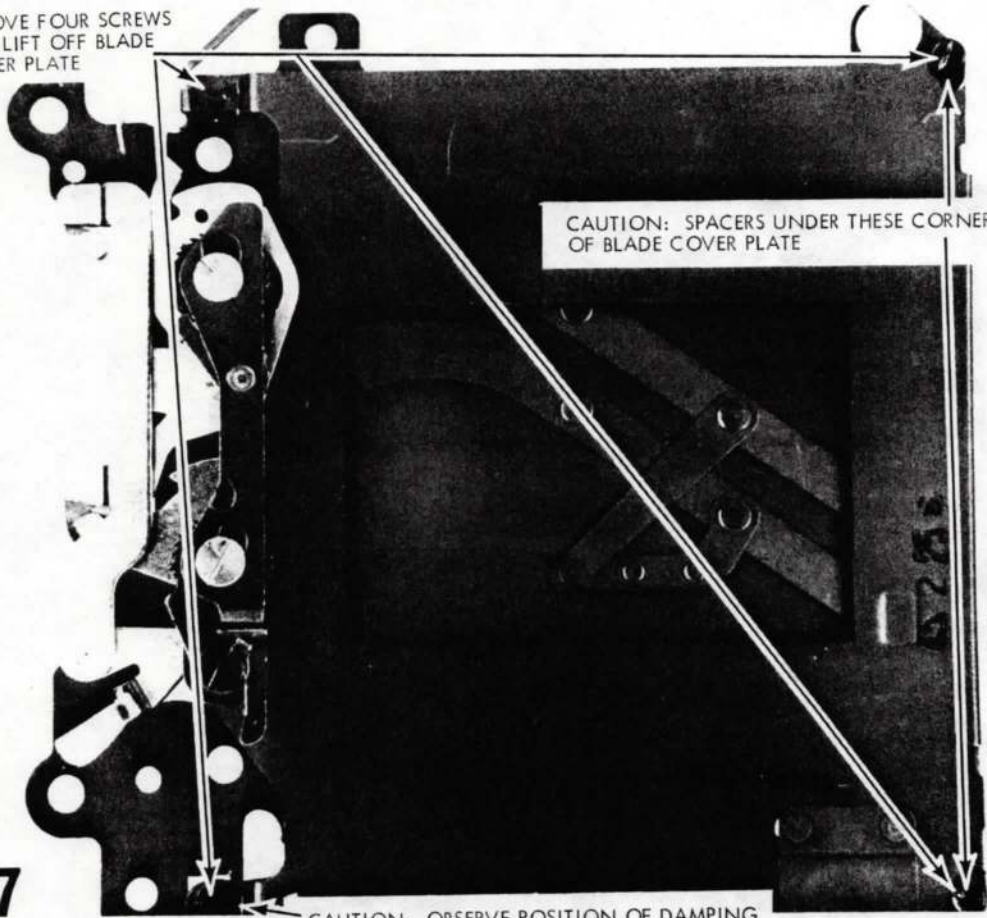

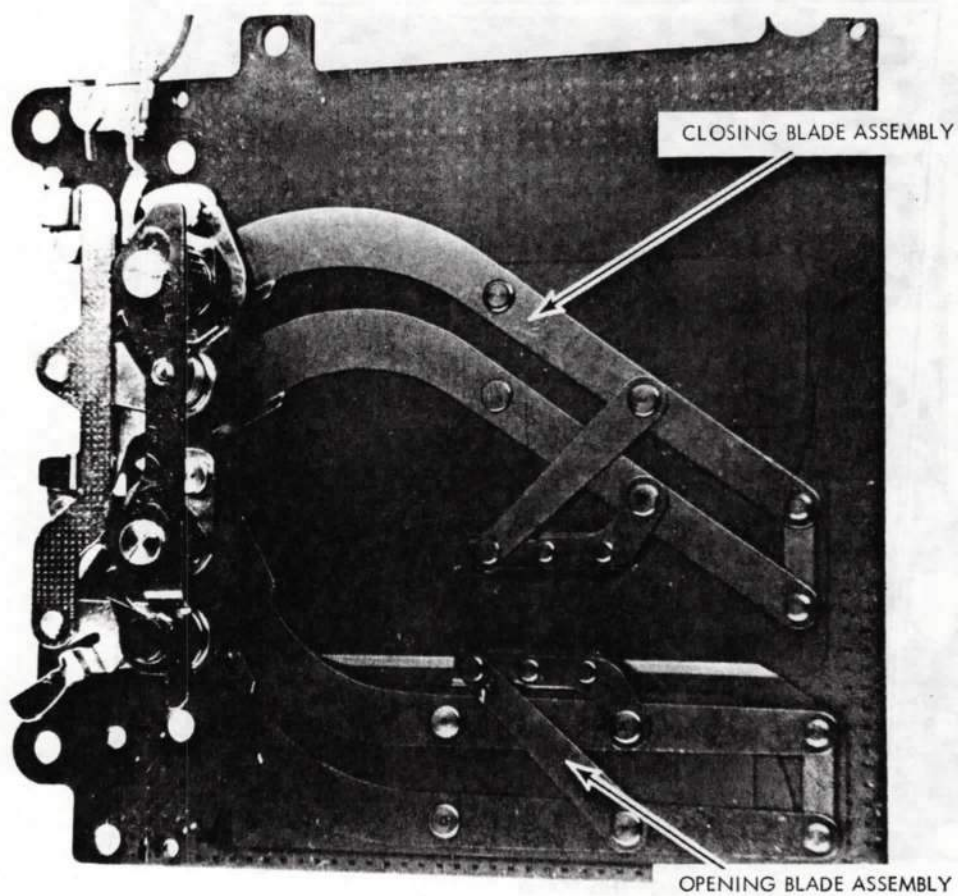

28

INSIDE OF BLADE
COVER PLATE

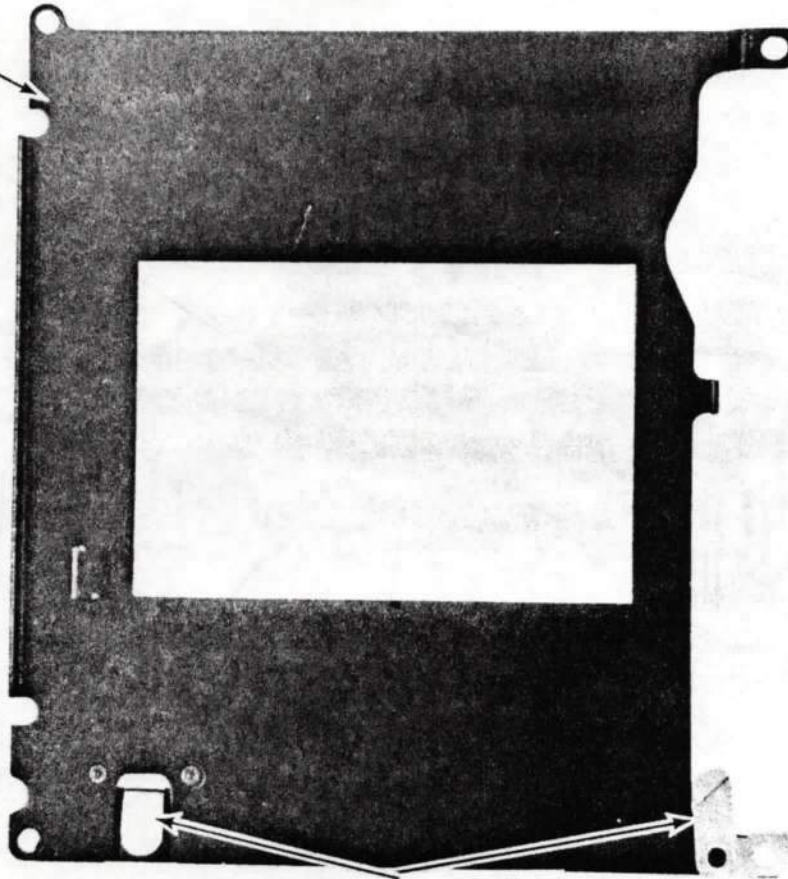

OPENING BLADE DAMPING SPRINGS

29

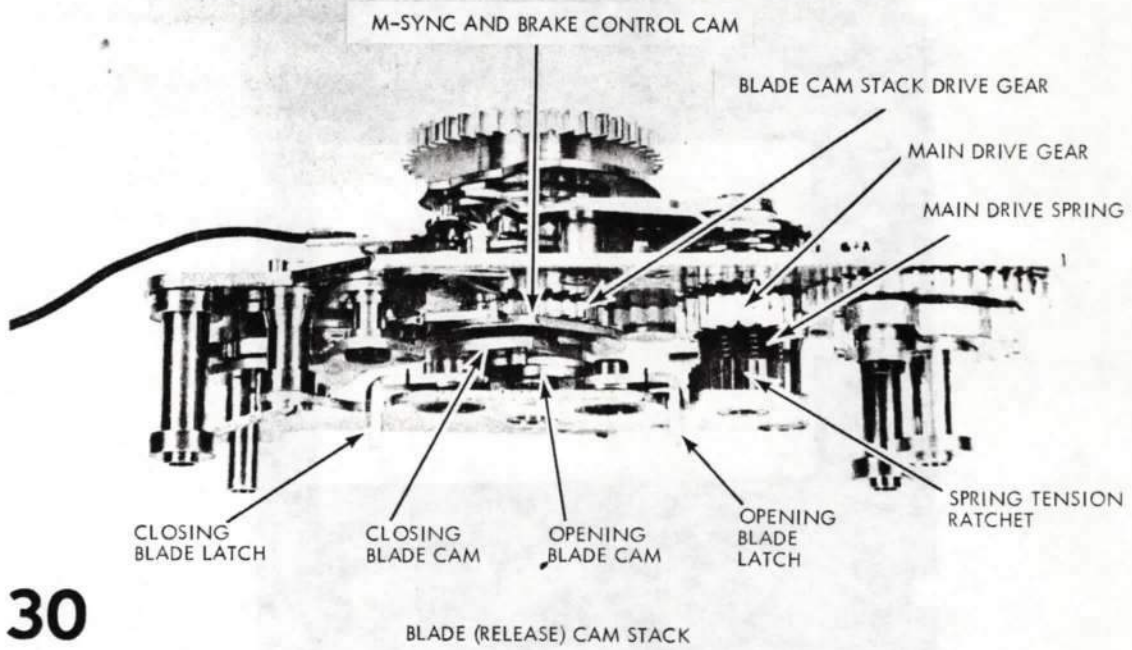

30

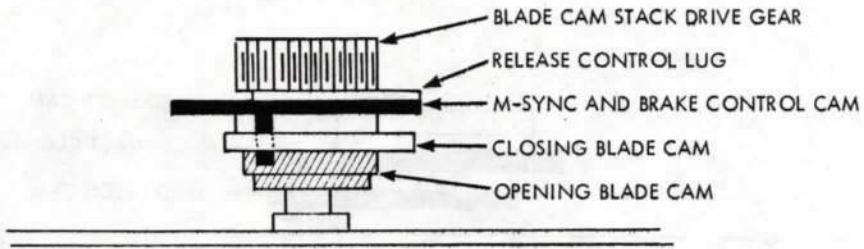

GRAPHIC SKETCH OF BLADE RELEASE CAM STACK
SHOWN IN FIGURE 30

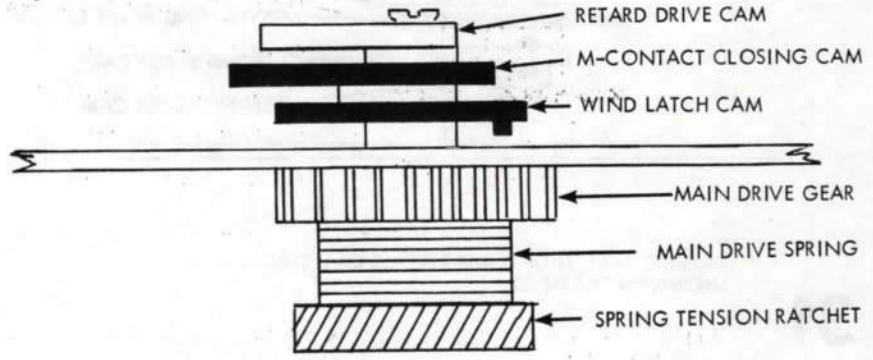

GRAPHIC SKETCH OF MAIN DRIVE CAM STACK

MAIN DRIVE
GEAR

RELEASE
PAWL

NYLON GEAR WHICH LINKS MAIN DRIVE GEAR
TO BLADE CAM STACK DRIVE GEAR

PIN ON PALLET ENGAGING LEVER
RIDES AGAINST M-SYNC AND BRAKE CONTROL
CAM

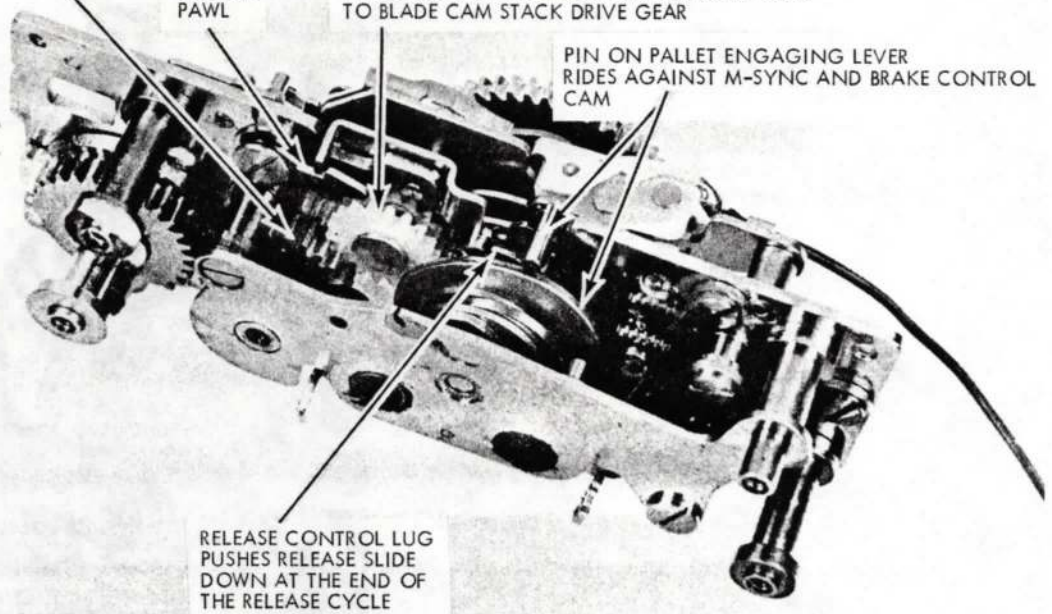

RELEASE CONTROL LUG
PUSHES RELEASE SLIDE
DOWN AT THE END OF
THE RELEASE CYCLE

33

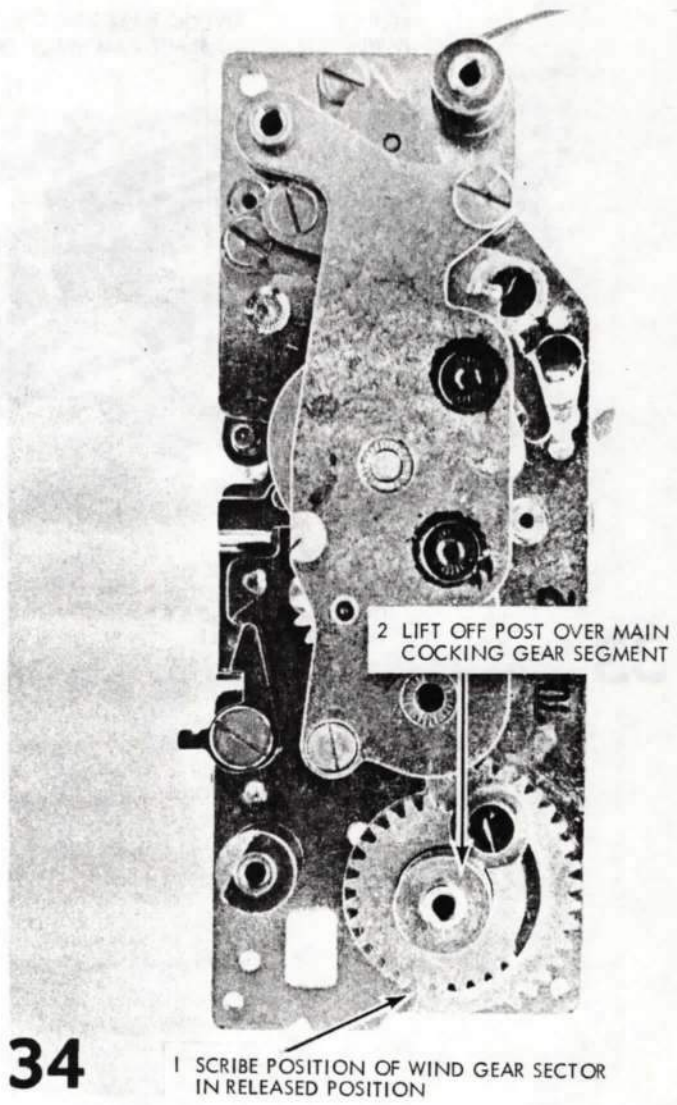

34

1 SCRIBE POSITION OF WIND GEAR SECTOR
IN RELEASED POSITION

2 LIFT OFF POST OVER MAIN
COCKING GEAR SEGMENT

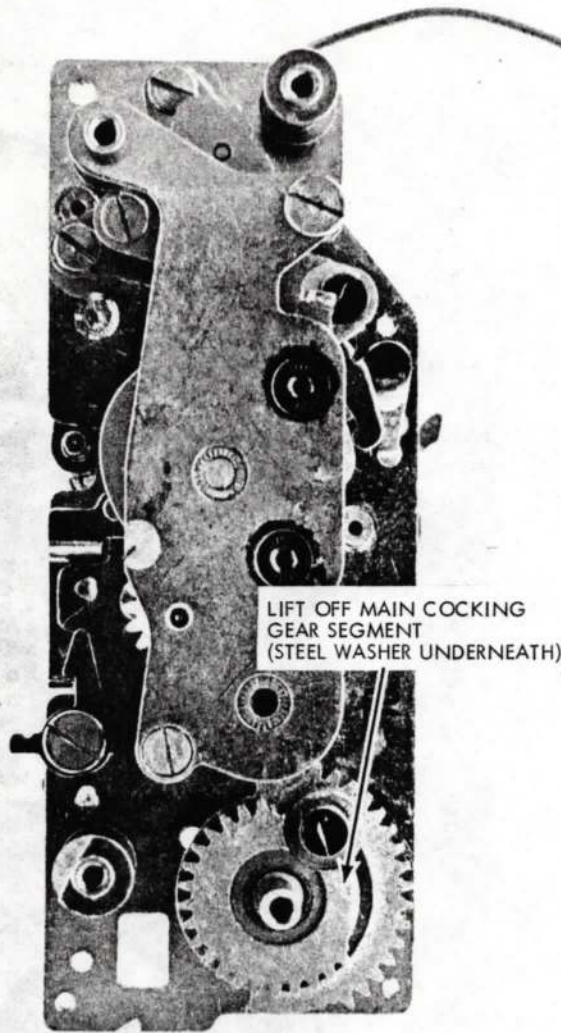

LIFT OFF MAIN COCKING
GEAR SEGMENT
(STEEL WASHER UNDERNEATH)

35



LIFT OFF WIND GEAR SECTOR
(COPPER WASHER UNDERNEATH)

1 SET SHUTTER SPEED SETTING GEAR
TO "BULB"

2 HOLD GEAR AND REMOVE SCREW --
LIFT OFF SHUTTER SPEED SETTING GEAR

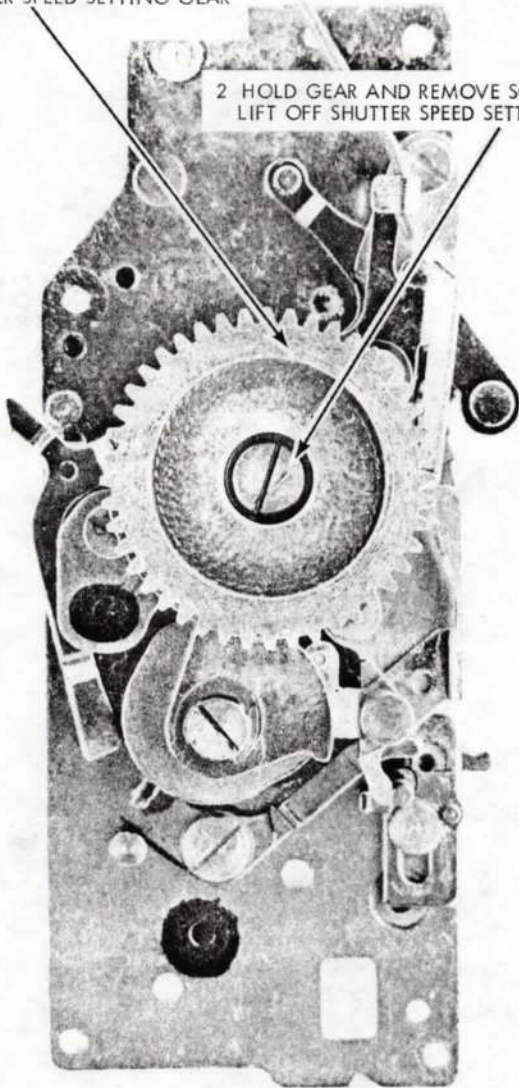

37

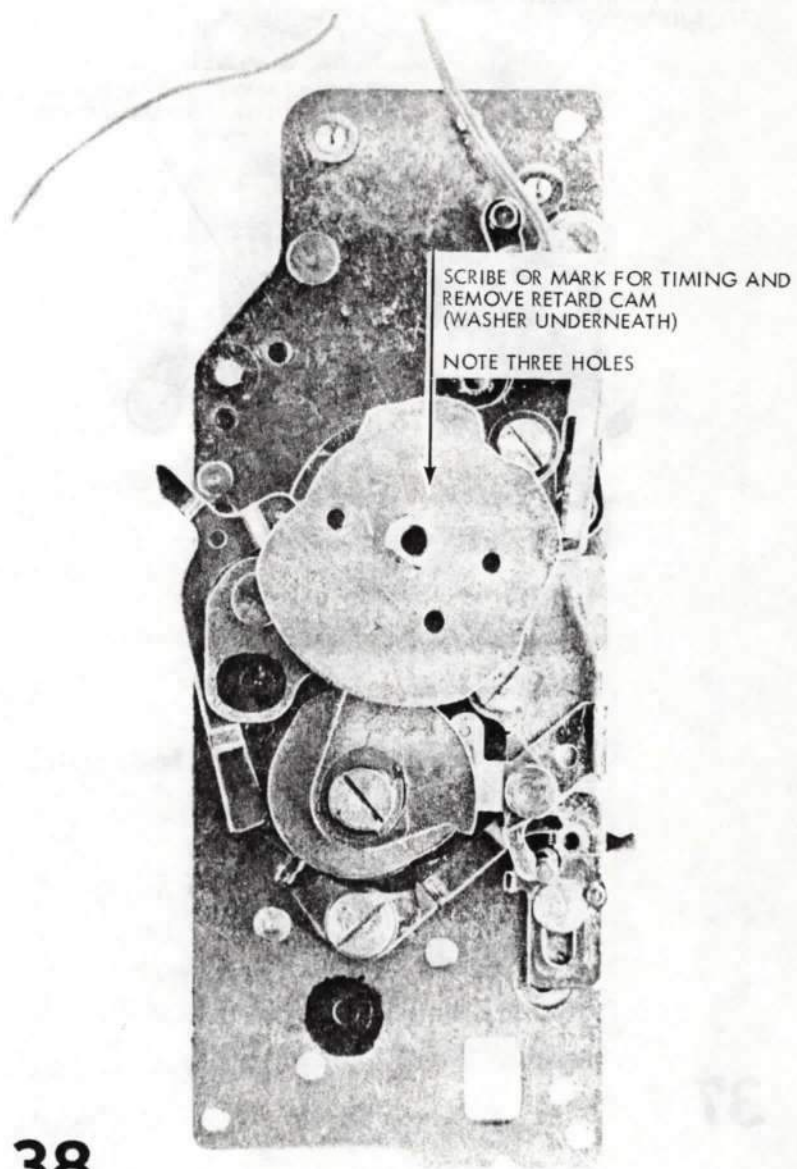

38

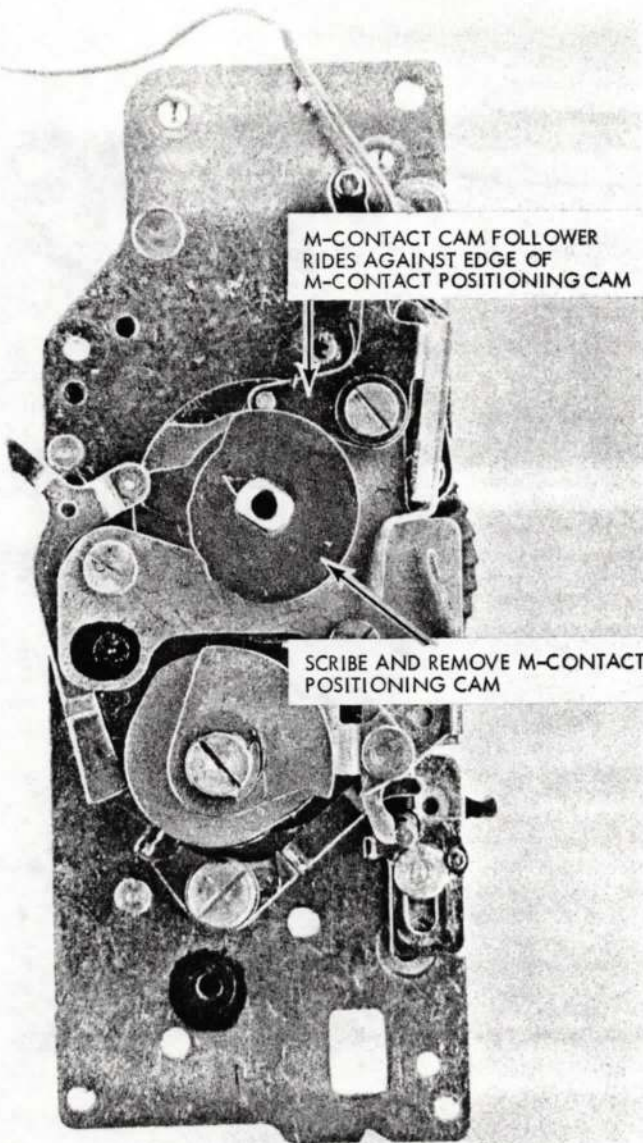

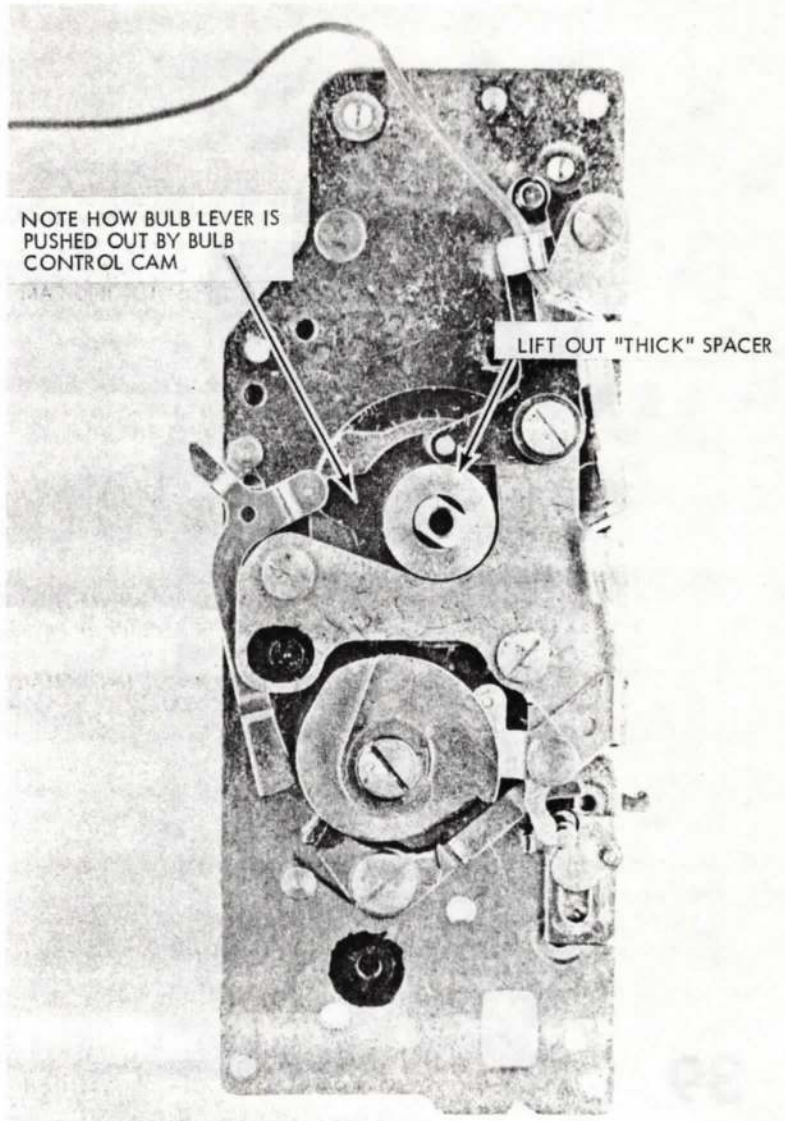

40

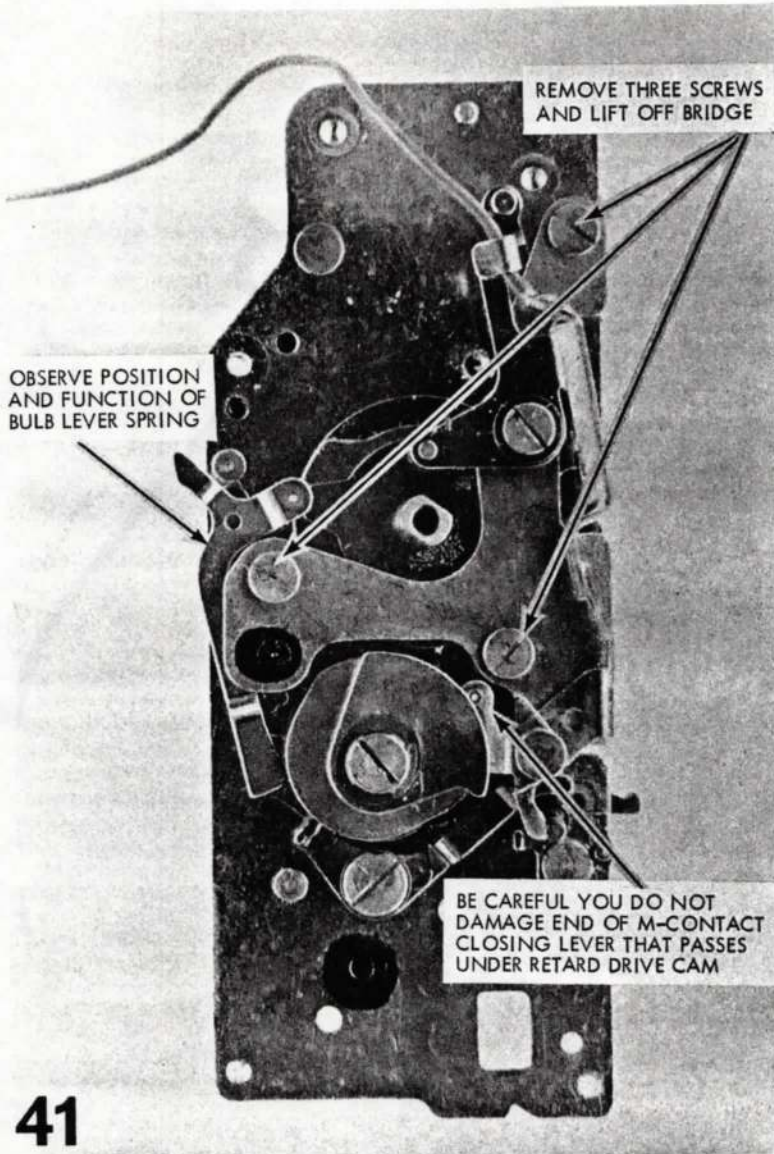

UNDERSIDE OF BRIDGE

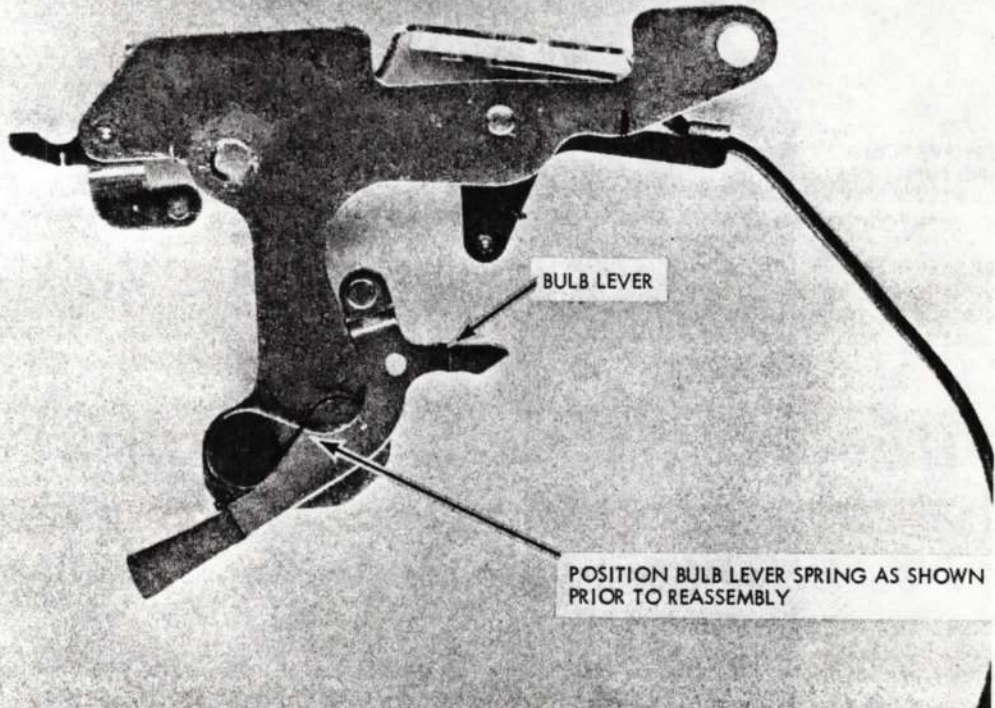

LONG END OF BULB
LEVER SPRING HOOKS
TO THE INSIDE OF THIS
POST

SCRIBE AND REMOVE
BULB CONTROL CAM
(WASHER UNDERNEATH)

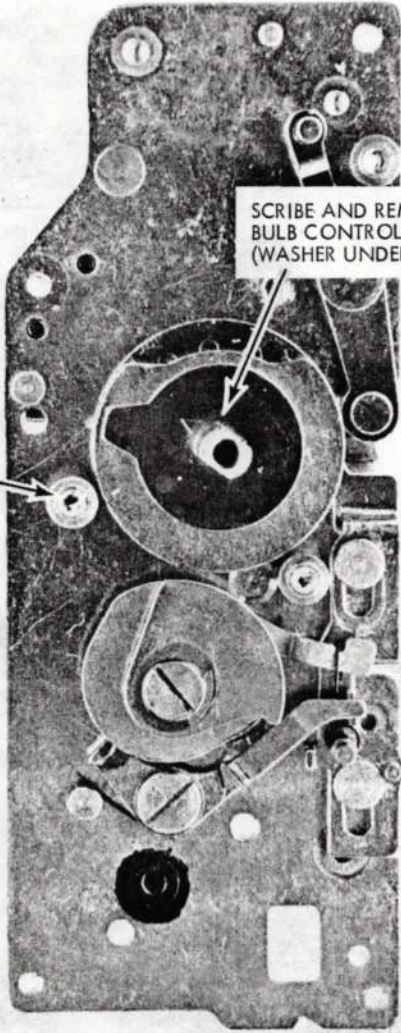

43

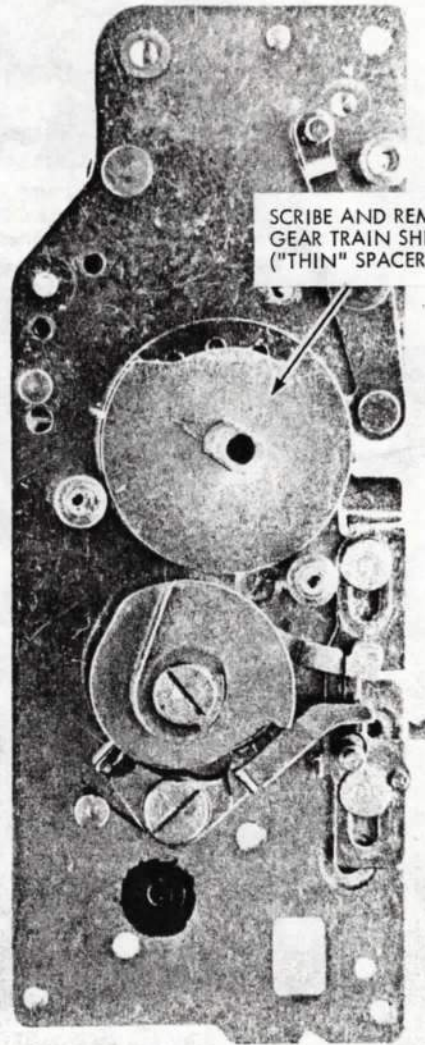

SCRIBE AND REMOVE
GEAR TRAIN SHIFT CAM
("THIN" SPACER UNDERNEATH)

44

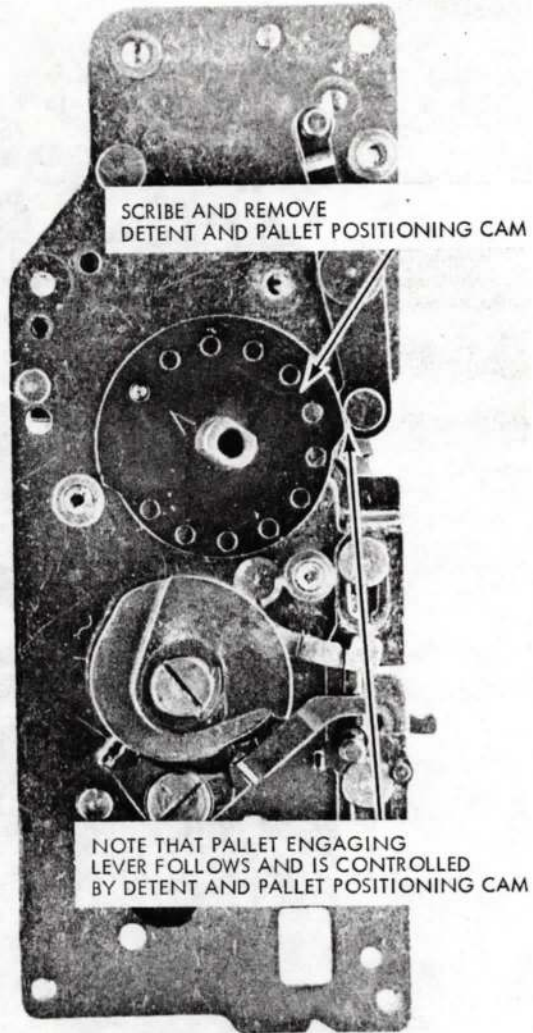

45

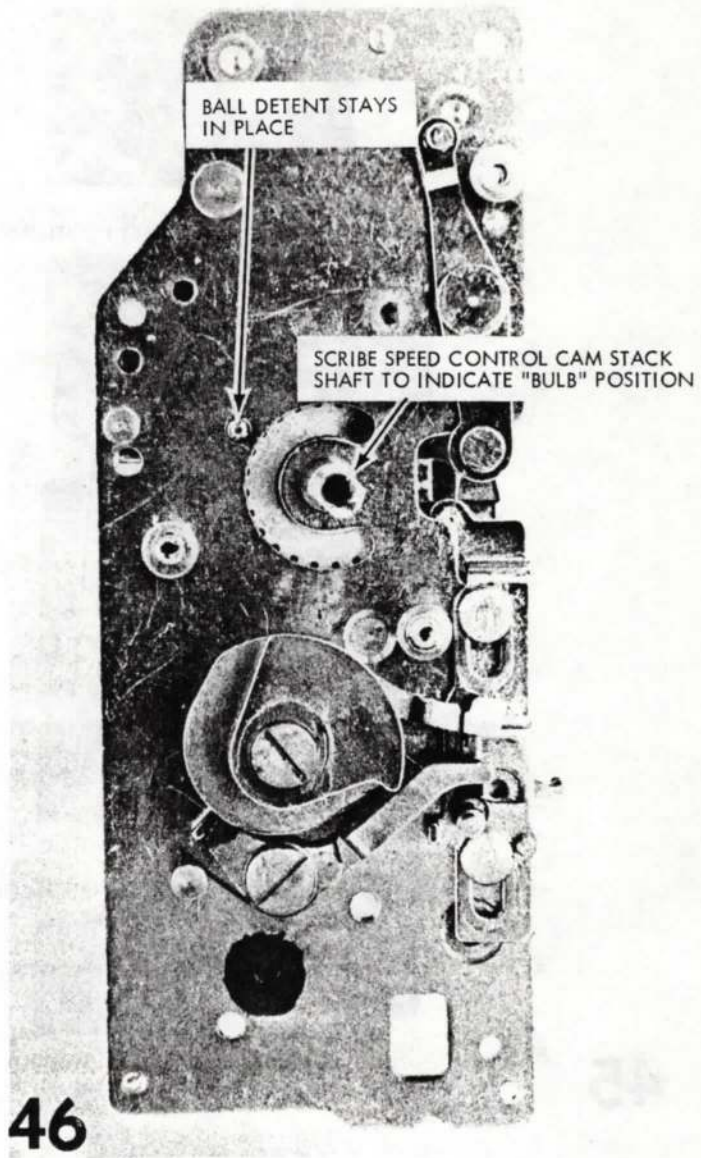

SPEED CONTROL CAMS IN ORDER OF REASSEMBLY

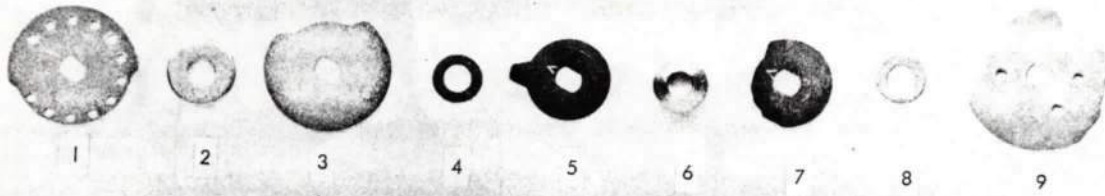

1 DETENT AND PALLET POSITIONING CAM

2 THIN SPACER

3 GEAR TRAIN SHIFT CAM

4 WASHER

5 BULB CONTROL CAM

6 THICK SPACER

7 M-CONTACT POSITIONING CAM

8 WASHER

9 RETARD CAM

47

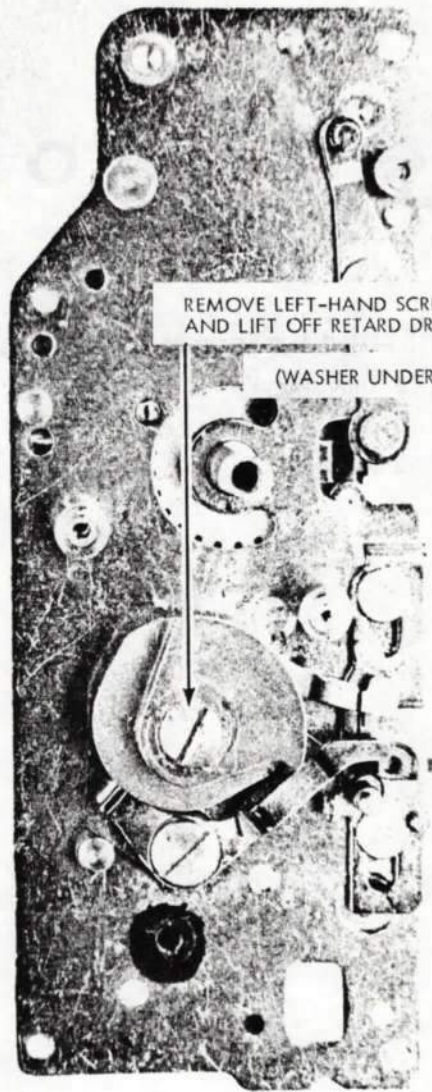

REMOVE LEFT-HAND SCREW
AND LIFT OFF RETARD DRIVE CAM

(WASHER UNDERNEATH)

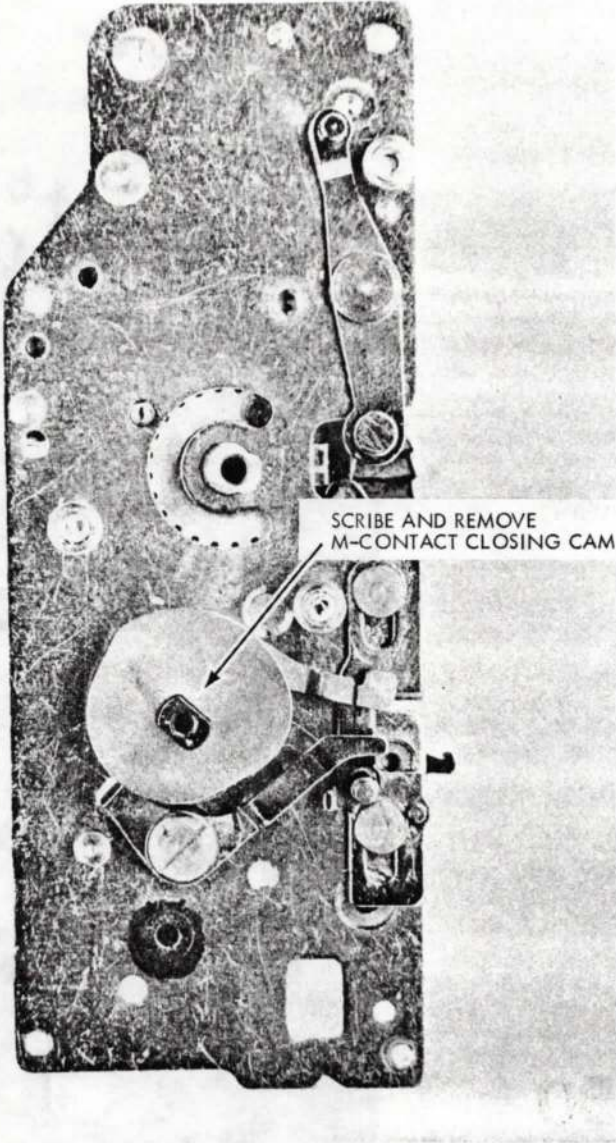

49

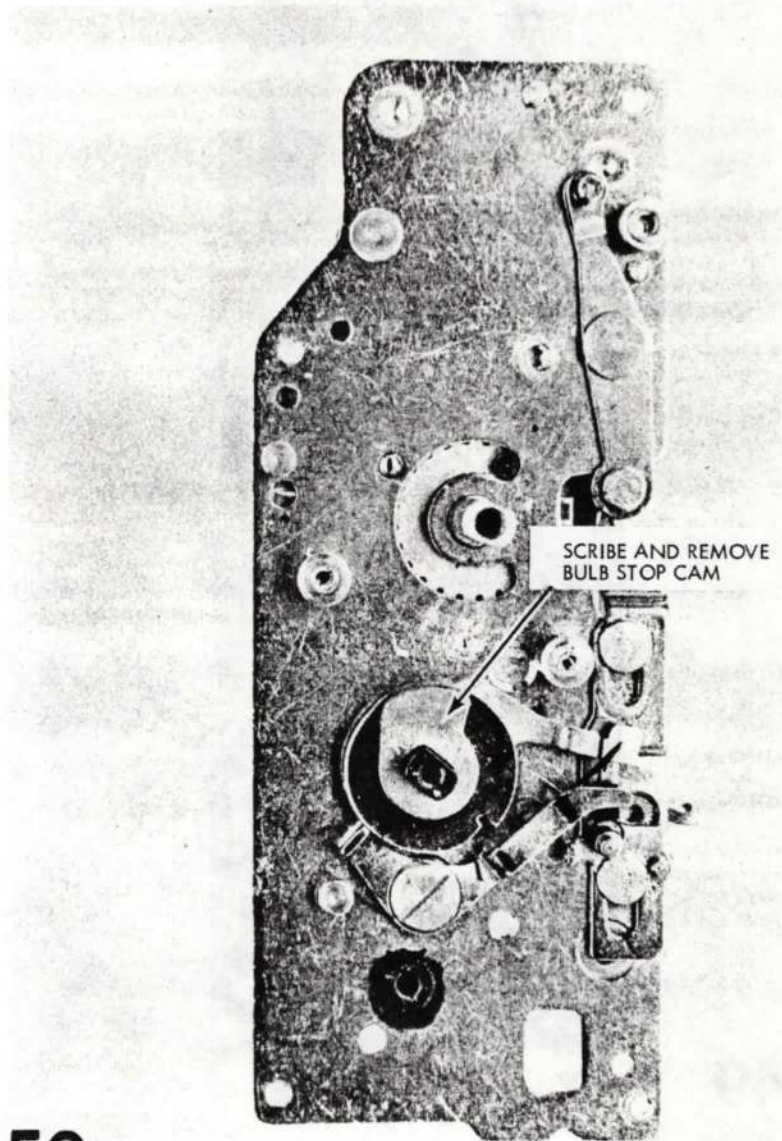

50



SCRIBE AND REMOVE
WIND LATCH CAM
("KEYED" WASHER UNDERNEATH)

NOTE NOTCH ON EDGE OF WIND LATCH CAM
THAT IS ENGAGED BY INNER RELEASE LEVER
IN COCKED POSITION

PIN ON BOTTOM OF WIND LATCH CAM CONTROLS
SPRING TENSIONING LEVER (SEE FIGURE 53)

51

MAIN DRIVE CAMS, SHOWING ORDER OF REASSEMBLY

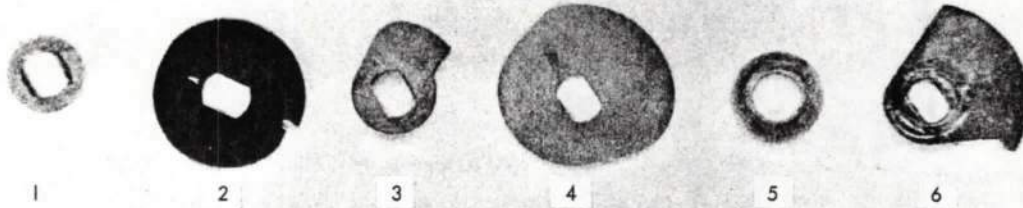

- | | |
|------------------|-------------------------|
| 1 "KEYED" WASHER | 4 M-CONTACT CLOSING CAM |
| 2 WIND LATCH CAM | 5 WASHER |
| 3 BULB STOP CAM | 6 RETARD DRIVE CAM |

SPRING
TENSIONING
LEVER

RELEASE
SLIDE

DRIVE CAM
SHAFT

INNER
RELEASE
LEVER

53

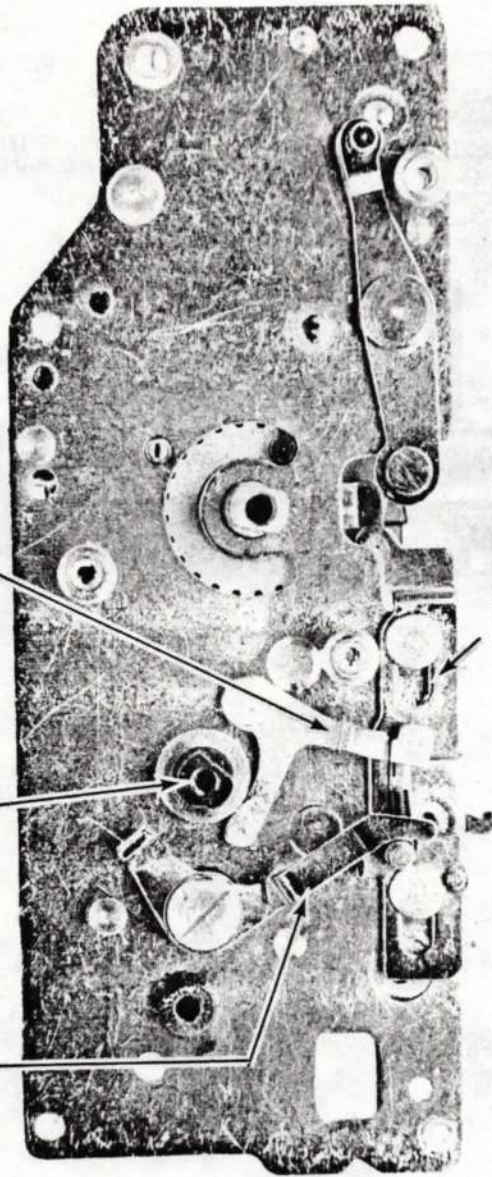



SCRIBE POSITION OF SPRING TENSION RATCHET
WITH RESPECT TO REAR MECHANISM PLATE

THE INITIAL TENSION (APPROXIMATELY 3/4
TURN) MUST BE REPLACED ON THE MAIN DRIVE
SPRING DURING REASSEMBLY

54

DISENGAGE PAWL TO LET OFF INITIAL TENSION
FROM MAIN DRIVE SPRING

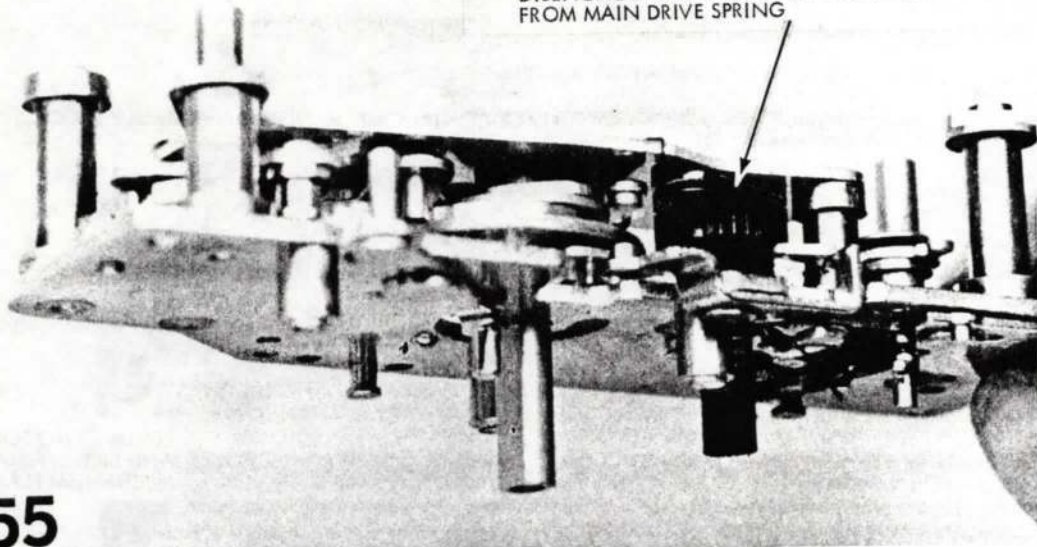

55

PLACE CONTROL MECHANISM ON ASSEMBLY BLOCK

REMOVE TWO SCREWS
AND LIFT OFF REAR
MECHANISM PLATE

56

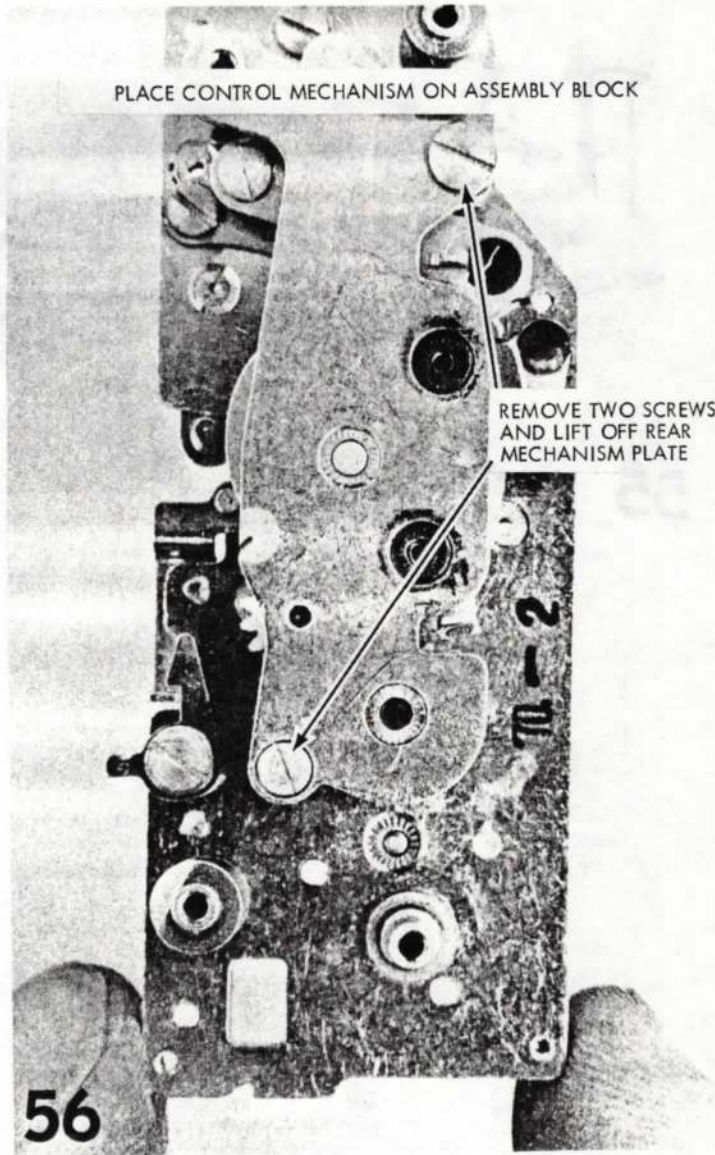

UNDERSIDE OF REAR MECHANISM PLATE

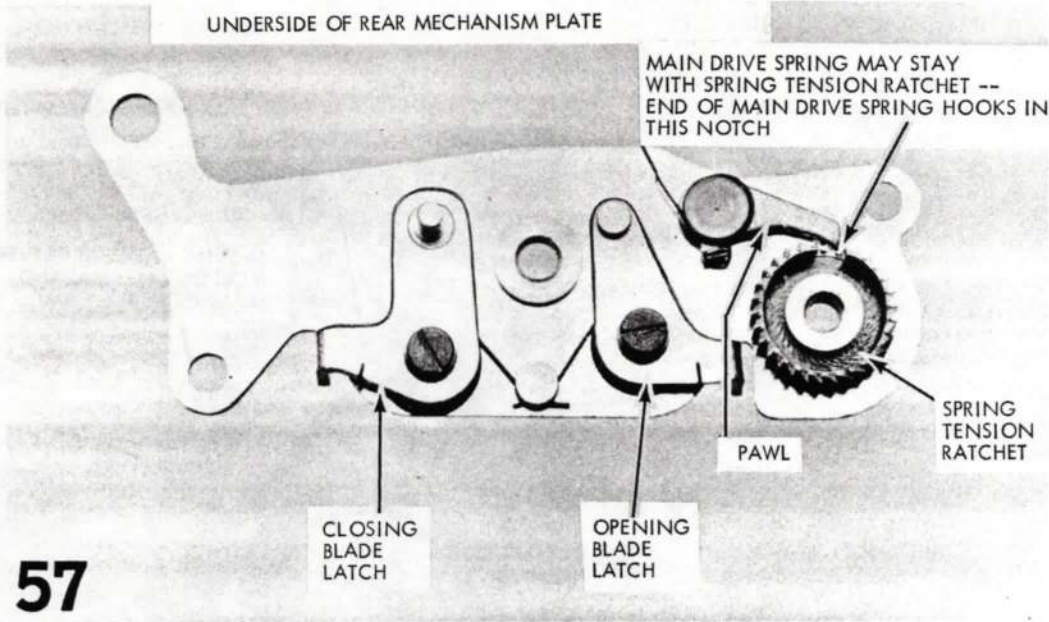

M-SYNC AND BRAKE ESCAPEMENT

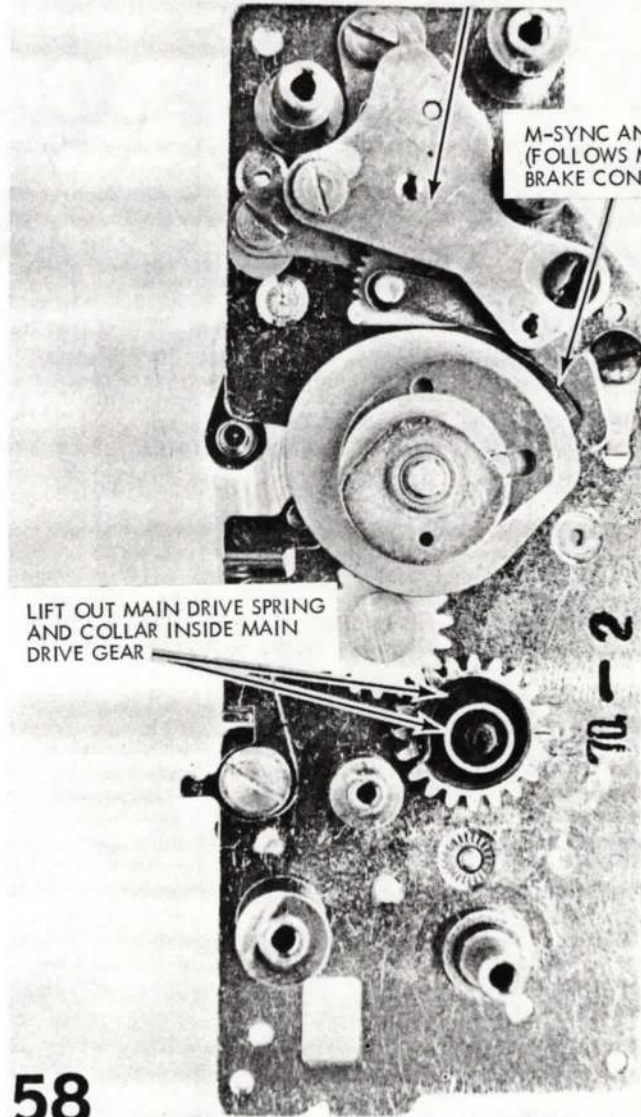

M-SYNC AND BRAKE LEVER
(FOLLOWS M-SYNC AND
BRAKE CONTROL CAM)

LIFT OUT MAIN DRIVE SPRING
AND COLLAR INSIDE MAIN
DRIVE GEAR

70-2

NOTE: TURN M-SYNC AND BRAKE CONTROL CAM AS FAR AS IT WILL GO COUNTERCLOCKWISE BEFORE ALIGNING MAIN DRIVE GEAR ON REASSEMBLY.

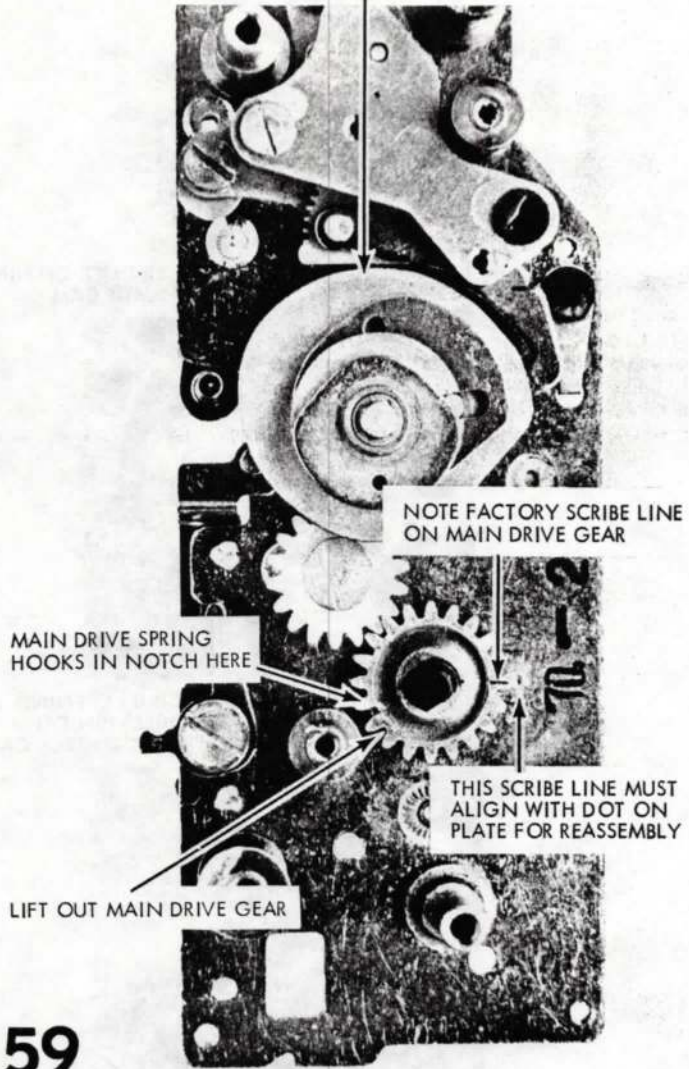

59

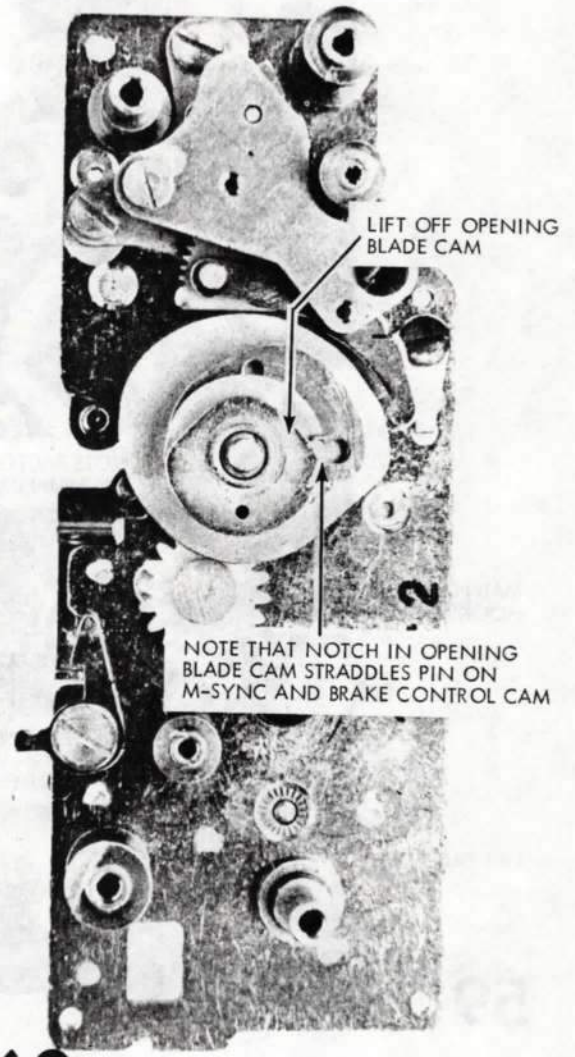

60

LIFT OFF CLOSING
BLADE CAM

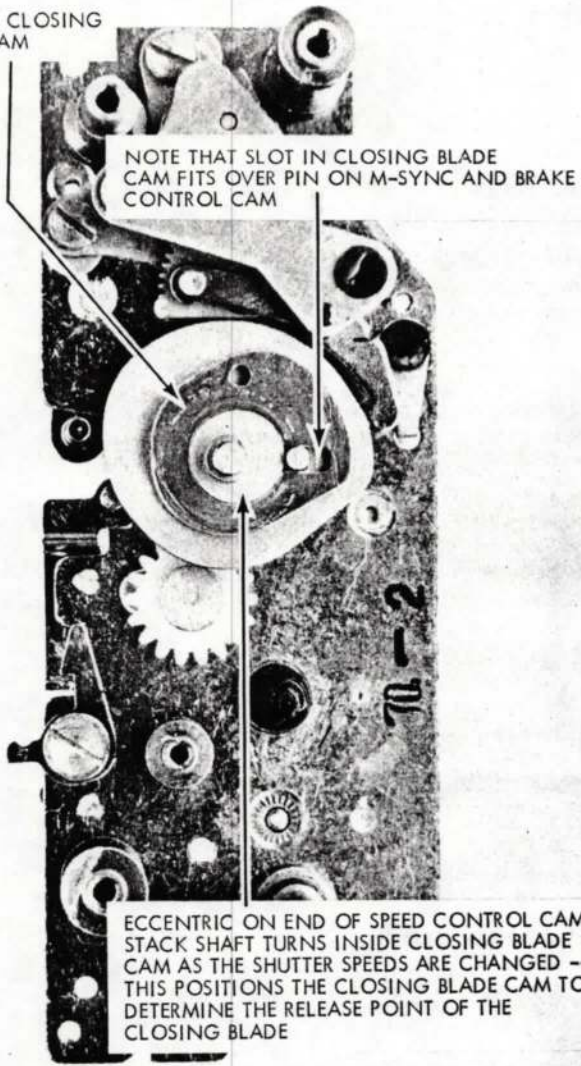

NOTE THAT SLOT IN CLOSING BLADE
CAM FITS OVER PIN ON M-SYNC AND BRAKE
CONTROL CAM

ECCENTRIC ON END OF SPEED CONTROL CAM
STACK SHAFT TURNS INSIDE CLOSING BLADE
CAM AS THE SHUTTER SPEEDS ARE CHANGED --
THIS POSITIONS THE CLOSING BLADE CAM TO
DETERMINE THE RELEASE POINT OF THE
CLOSING BLADE

61

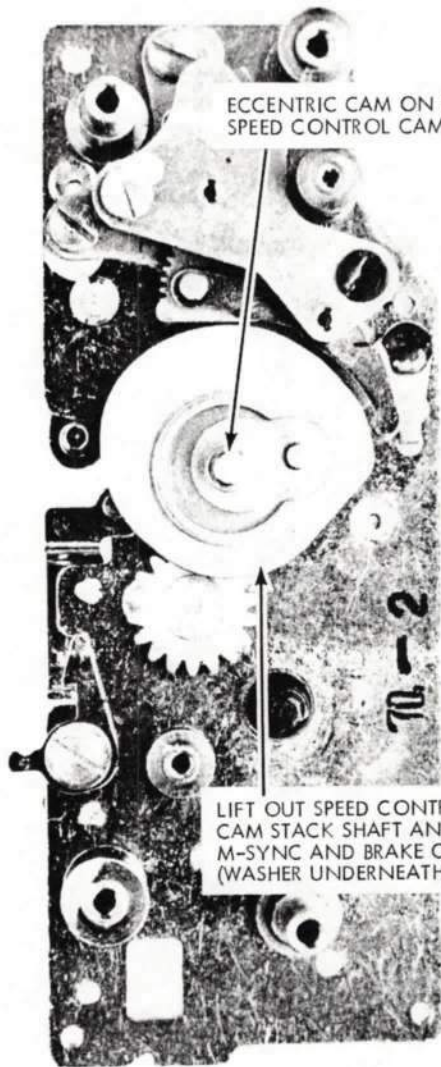

ECCENTRIC CAM ON END OF
SPEED CONTROL CAM STACK SHAFT

LIFT OUT SPEED CONTROL
CAM STACK SHAFT AND
M-SYNC AND BRAKE CONTROL CAM
(WASHER UNDERNEATH)

REMOVE THREE SCREWS AND LIFT OUT
M-SYNC AND BRAKE ESCAPEMENT



63