



Canon  
EF-EF

Canon  
EF-EF

Canon  
EF-EF

Canon  
EF-EF

Canon  
EF-EF

Canon  
EF-EF

Canon  
EF-EF



GREEN CIRCLE FOR AUTOMATIC-DIAPHRAGM CONTROL

DIAPHRAGM-SETTING RING

LED (LIGHT-EMITTING DIODE)

FLASHES DURING SLOW EXPOSURES AND WHEN YOU DEPRESS BATTERY-TEST BUTTON ON BOTTOM OF CAMERA

DIAPHRAGM-SETTING-RING LOCK BUTTON--DEPRESS TO SELECT AUTOMATIC SETTING

SHUTTER-SPEED DIAL

COUNTER WINDOW

SYNC-TERMINAL COVER

NEEDLE-HOLD BUTTON

HOT-SHOE COVER

WIND LEVER IN "STORAGE" POSITION

2

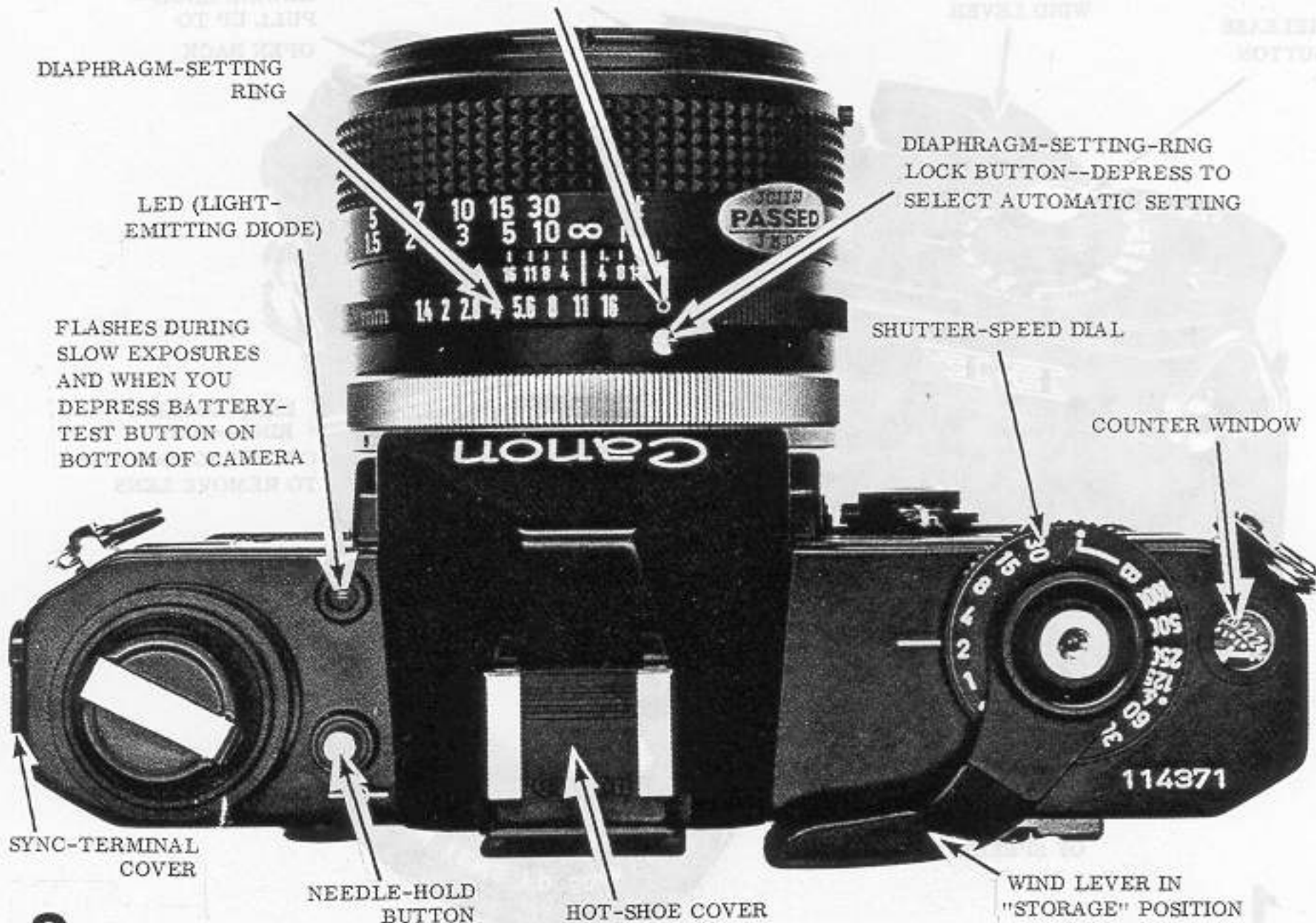

FILM-SPEED KNOB -- LIFT AND TURN TO SET FILM SPEED

INTENTIONAL DOUBLE-  
EXPOSURE BUTTON

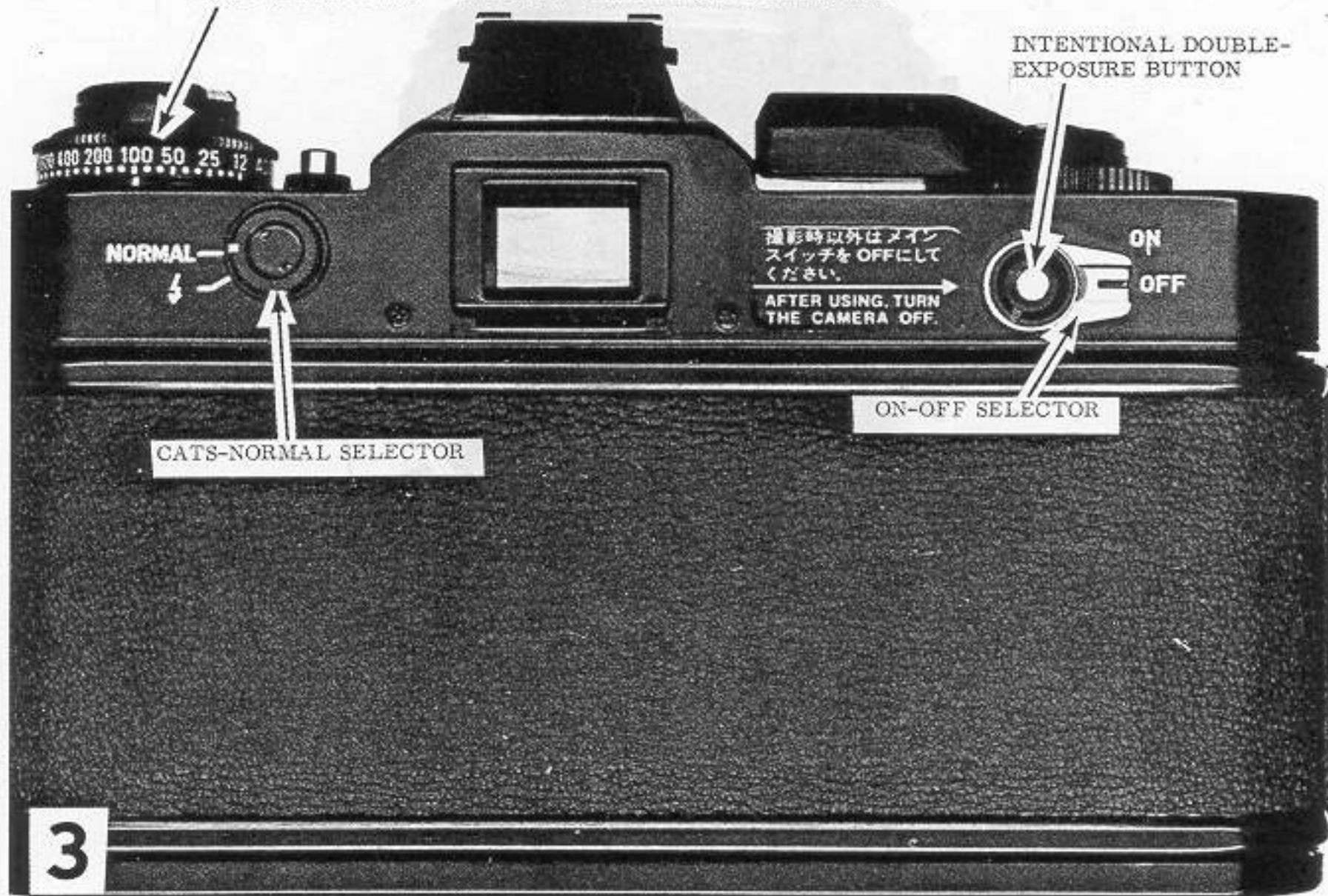

NORMAL

撮影時以外はメイン  
スイッチをOFFにして  
ください。

AFTER USING, TURN  
THE CAMERA OFF.

ON

OFF

CATS-NORMAL SELECTOR

ON-OFF SELECTOR

3

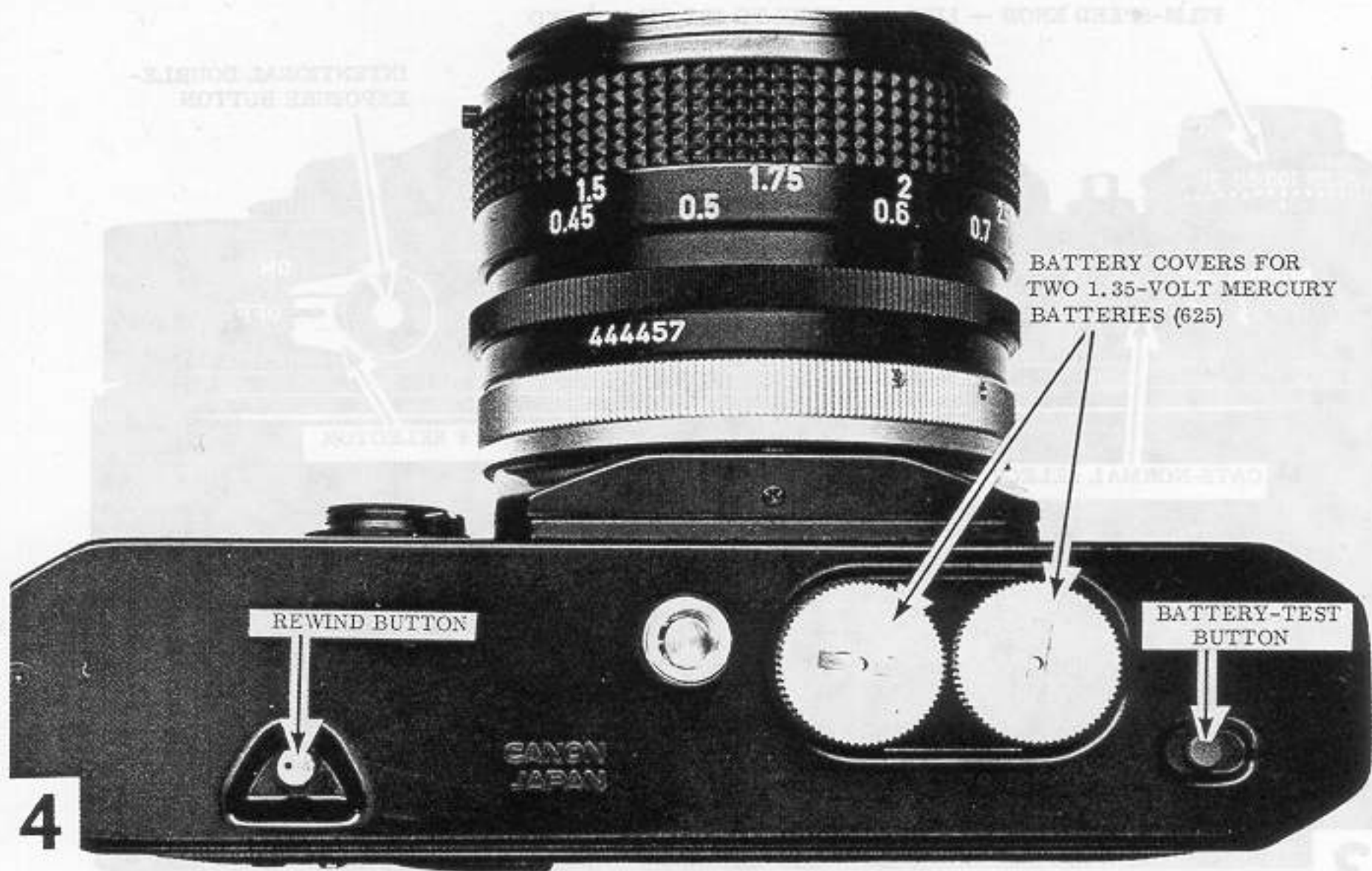

INTERNAL DOUBLE-  
EXPOSURE BUTTON

HD

FTO

INTERNAL

BATTERY COVERS FOR  
TWO 1.35-VOLT MERCURY  
BATTERIES (625)

INTERNAL

REWIND BUTTON

BATTERY-TEST  
BUTTON

SANGA  
JAPAN

4

3

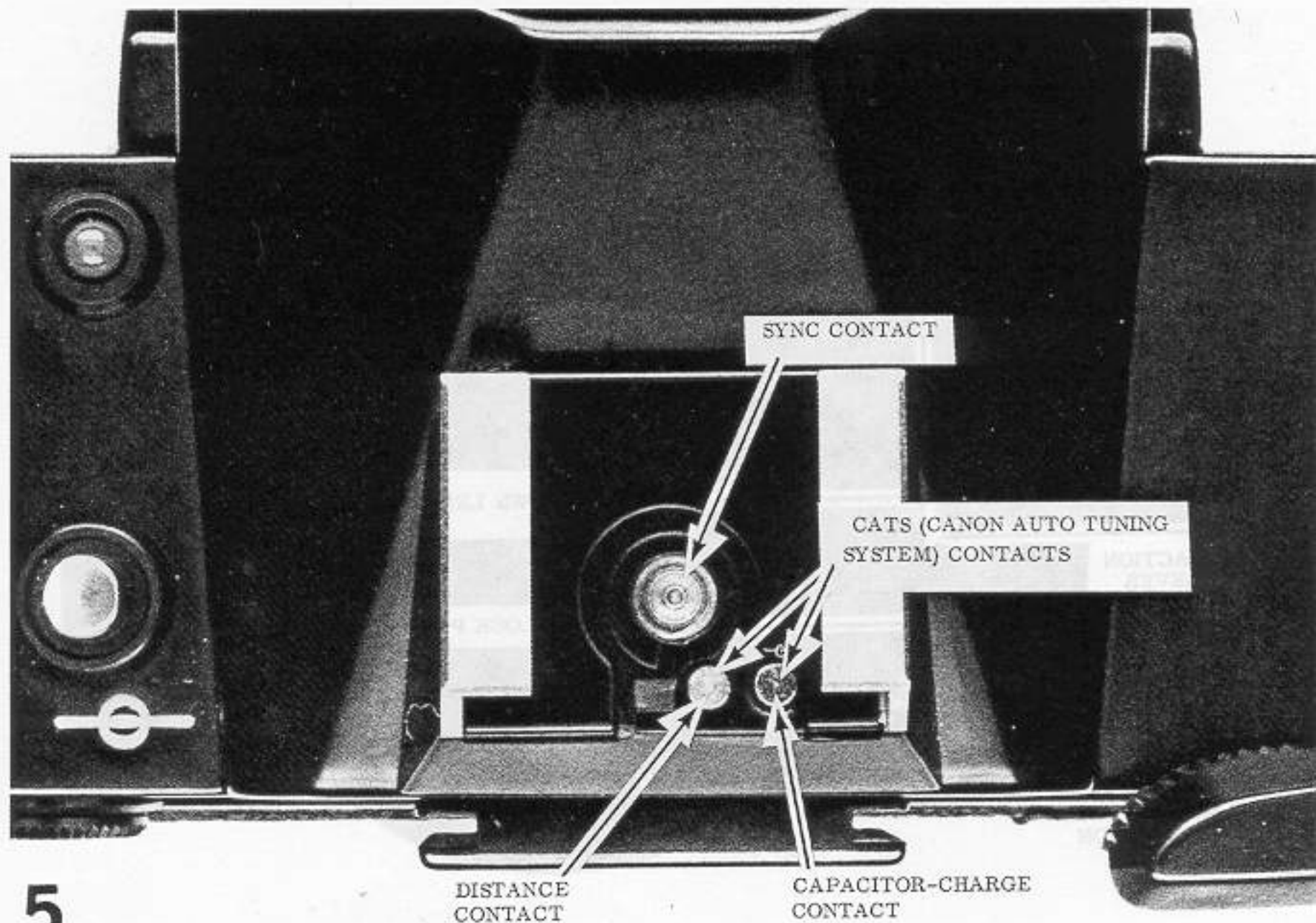

SYNC CONTACT

CATS (CANON AUTO TUNING  
SYSTEM) CONTACTS

DISTANCE  
CONTACT

CAPACITOR-CHARGE  
CONTACT

5

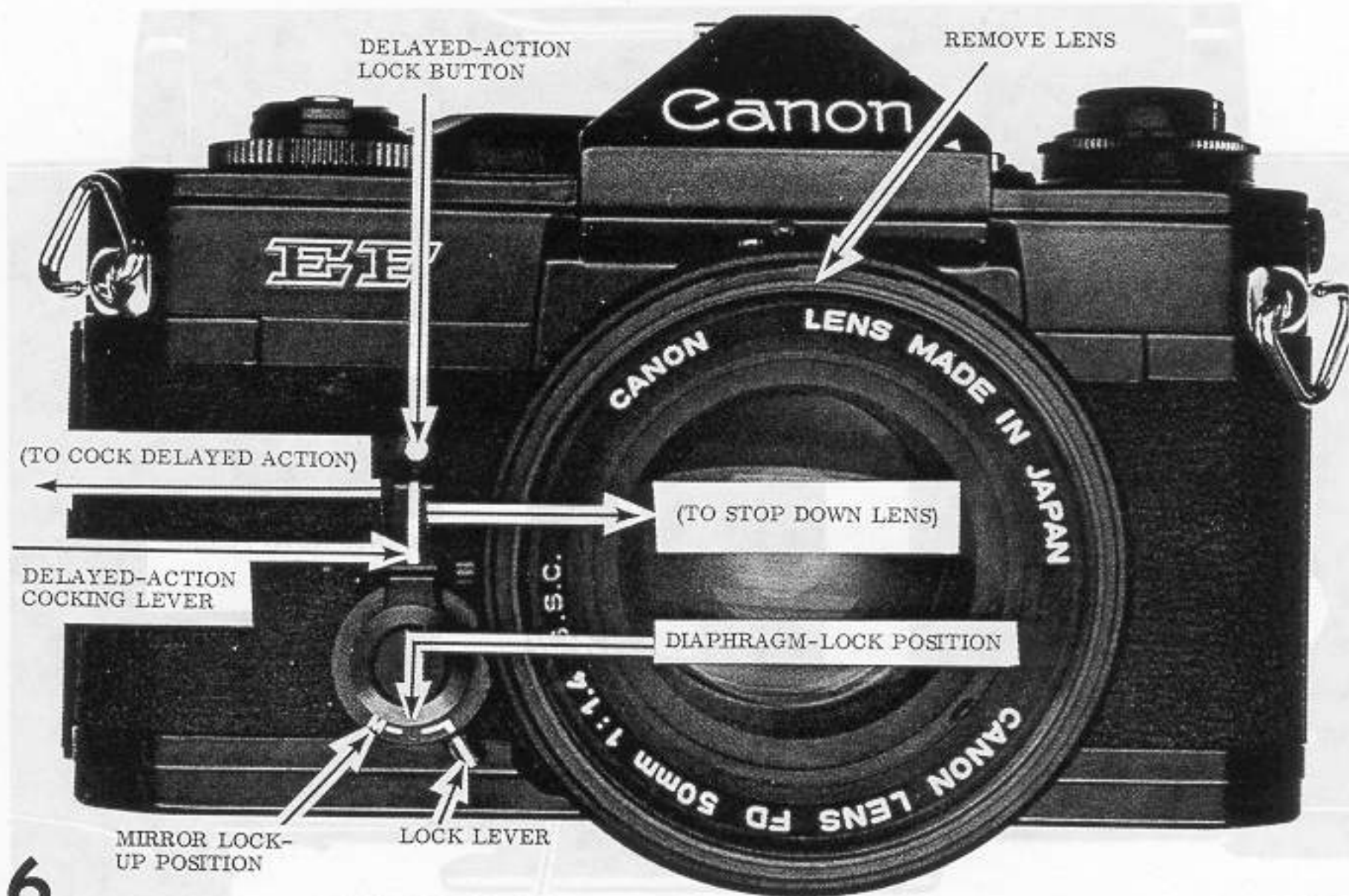

DELAYED-ACTION  
LOCK BUTTON

REMOVE LENS

Canon

F11

CANON LENS MADE IN JAPAN

S.C.

CANON LENS FD 50mm 1:1.4

(TO COCK DELAYED ACTION)

(TO STOP DOWN LENS)

DELAYED-ACTION  
COCKING LEVER

DIAPHRAGM-LOCK POSITION

MIRROR LOCK-  
UP POSITION

LOCK LEVER

6

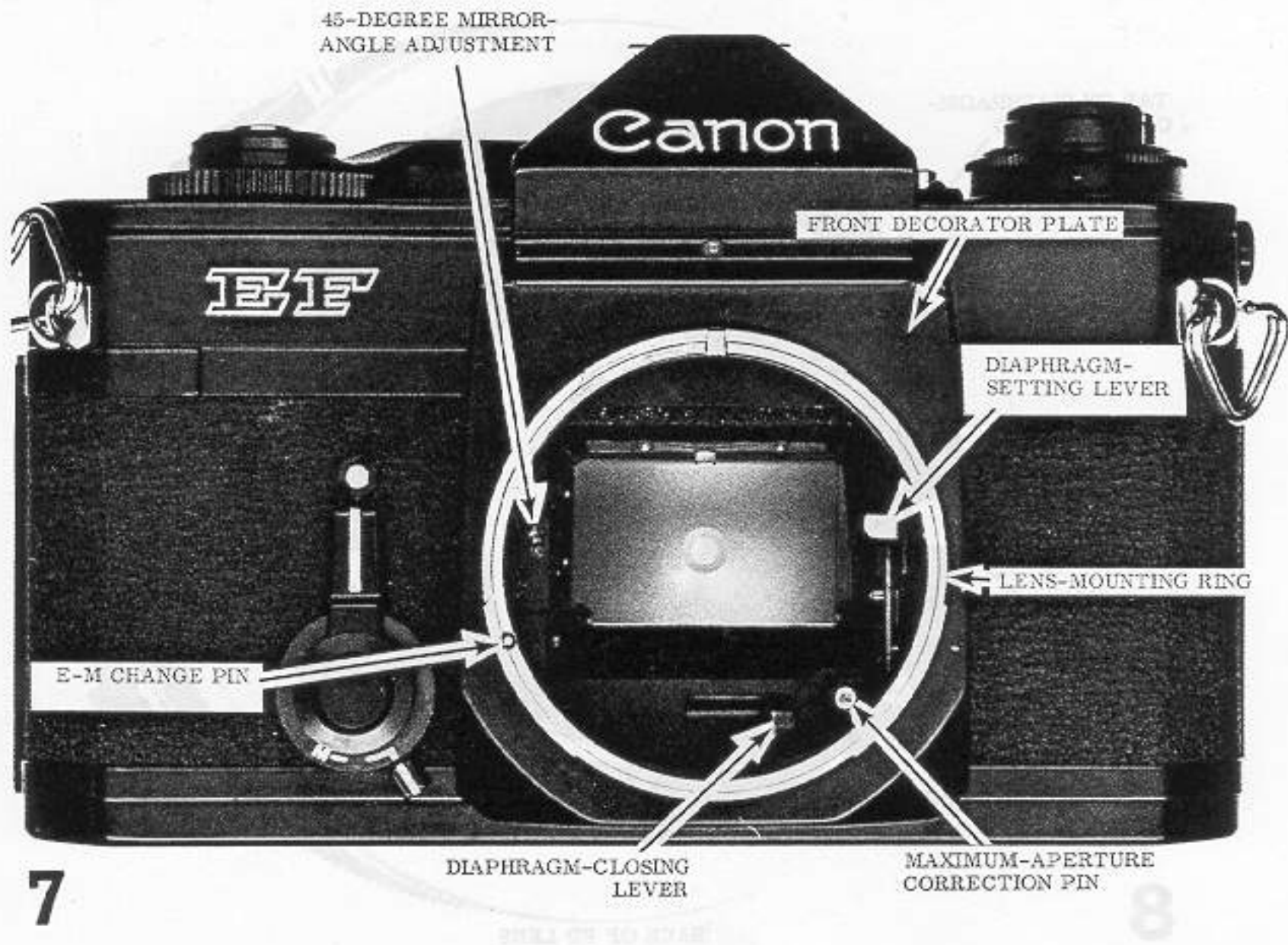

Check the flange-focal distance (42.14 mm) by measuring between the front surface of the lens-mounting ring and the film rails. To make an adjustment, first remove the screw at the bottom of the front decorator plate. Lift off the front decorator plate and remove the four screws holding the lens-mounting ring. You can now add or remove spacers to adjust the flange-focal distance and/or parallelism.

TAB ON DIAPHRAGM-  
COUPLING RING

FULL-OPEN  
METERING  
POST

TAB OF  
DIAPHRAGM-OPENING  
RING

AUTO PIN

8

BACK OF FD LENS

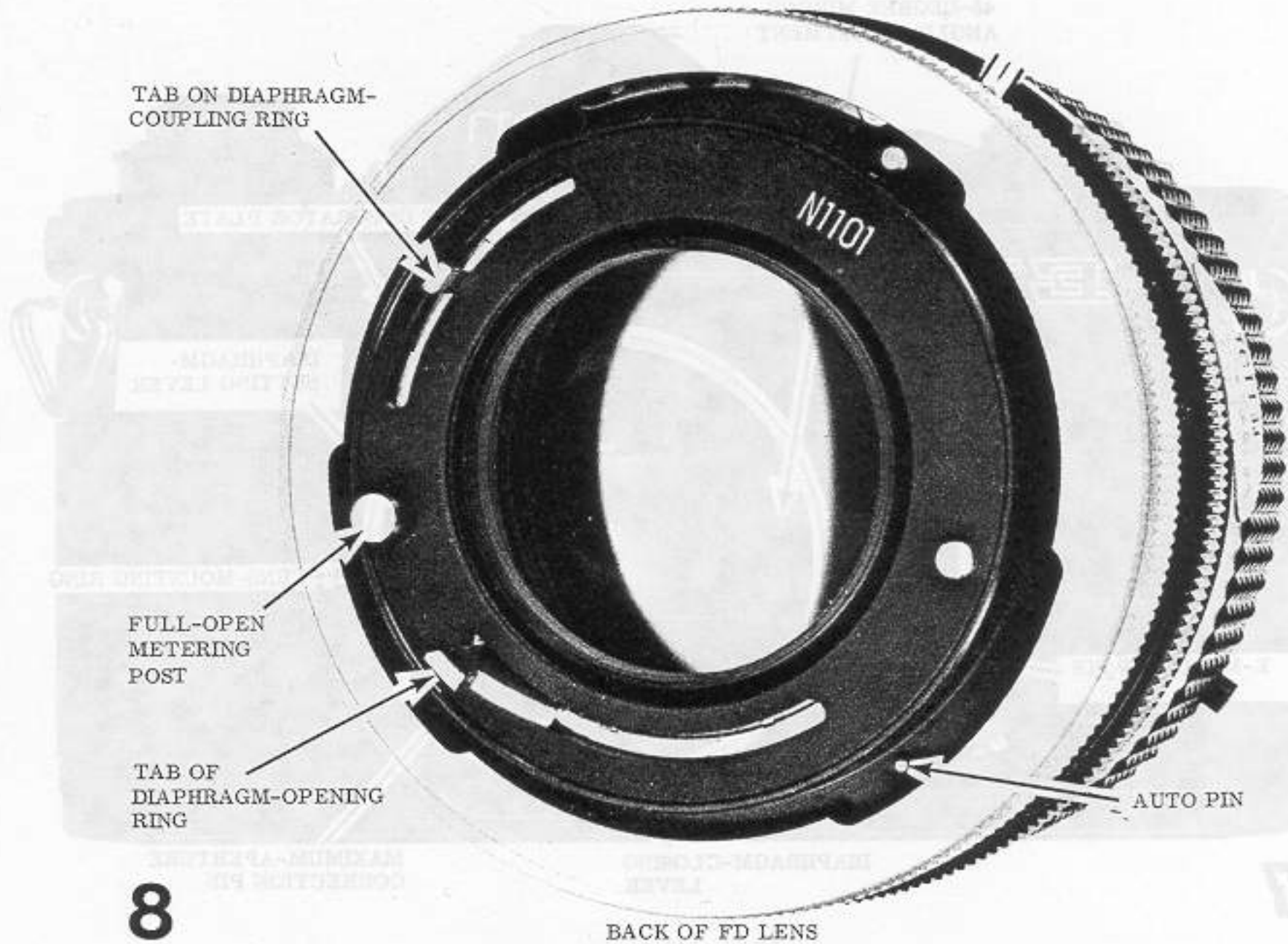

1. REMOVE BATTERY-COMPARTMENT COVERS AND BATTERIES

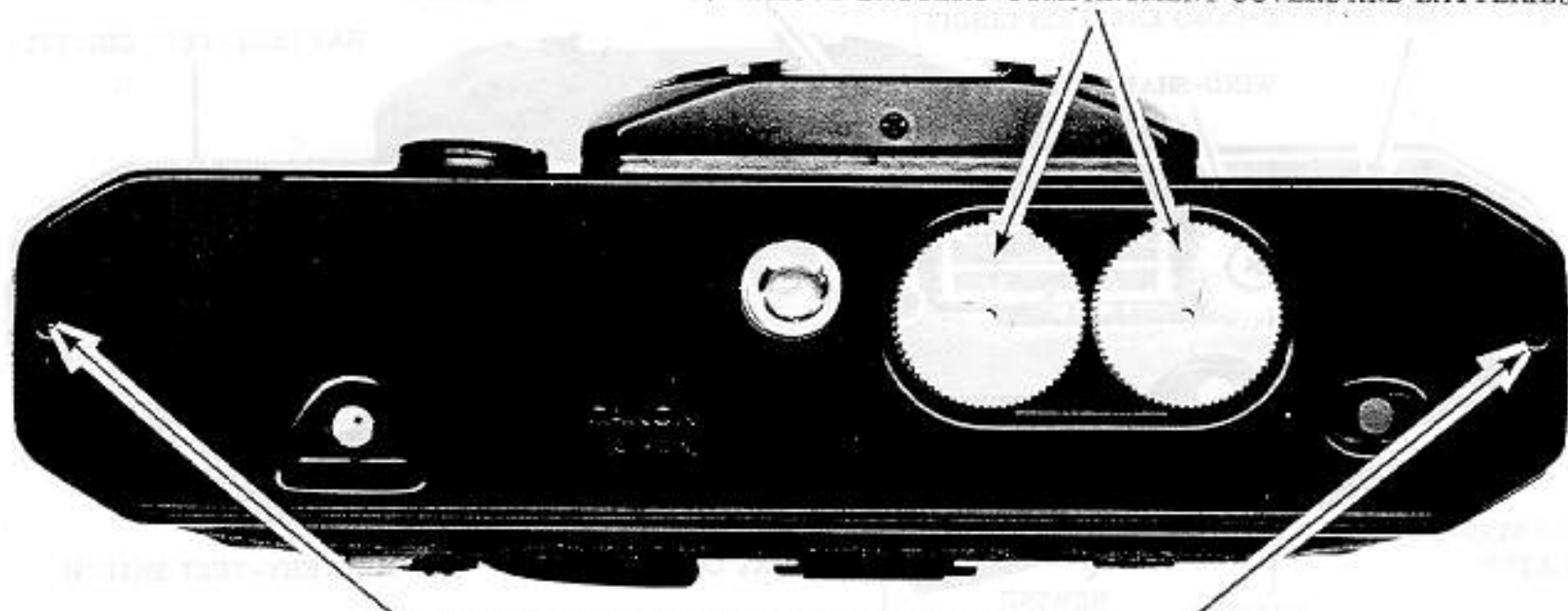

2. REMOVE TWO SCREWS AND LIFT OFF BOTTOM PLATE

CAUTION: BATTERY-TEST BUTTON WILL BE LOOSE WHEN YOU LIFT OFF BOTTOM PLATE

TURN METERING SECTOR TO  
POSITION SHOWN AND LIFT IT OUT

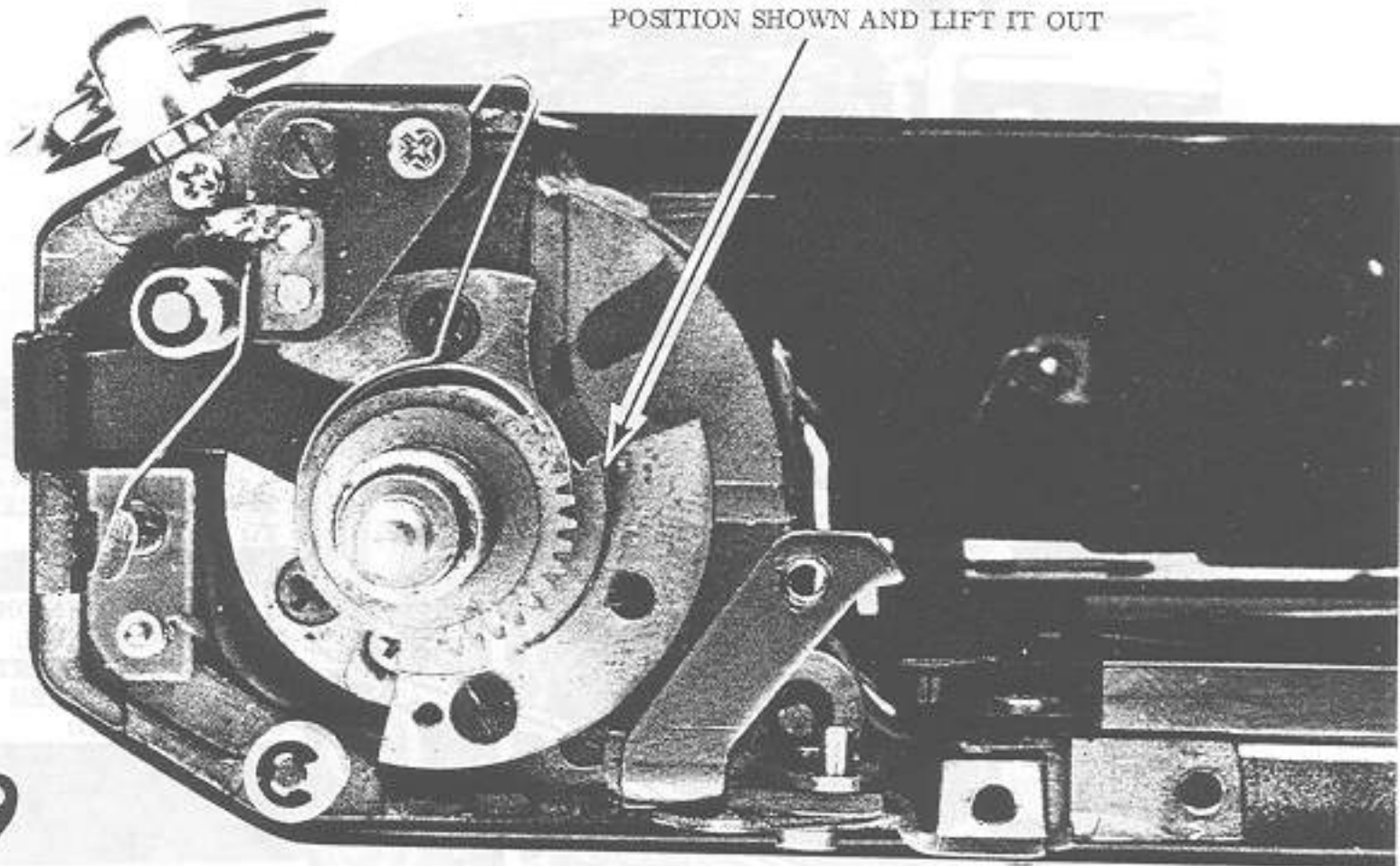

99

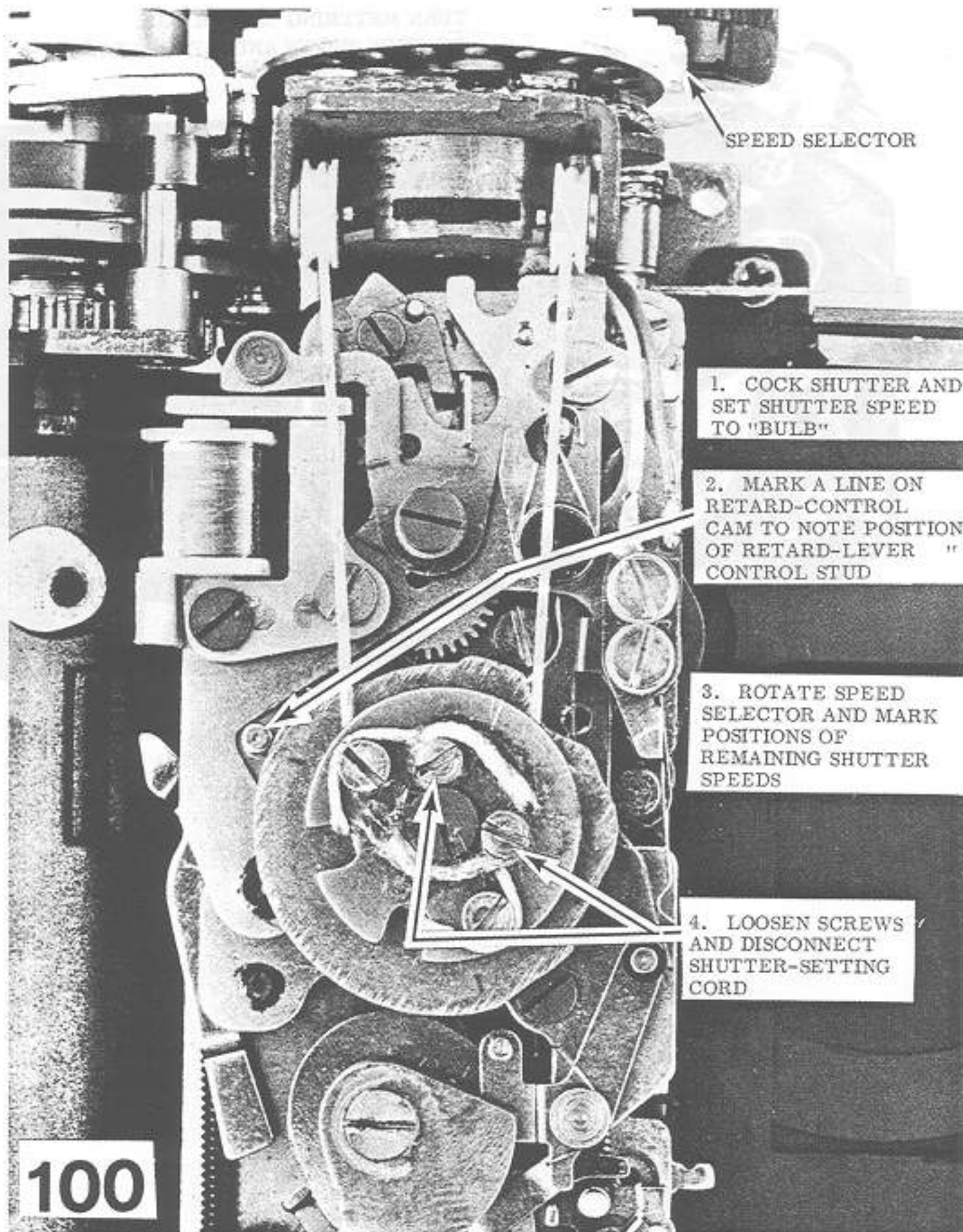

UNSOLDER BLUE X-SYNC WIRE

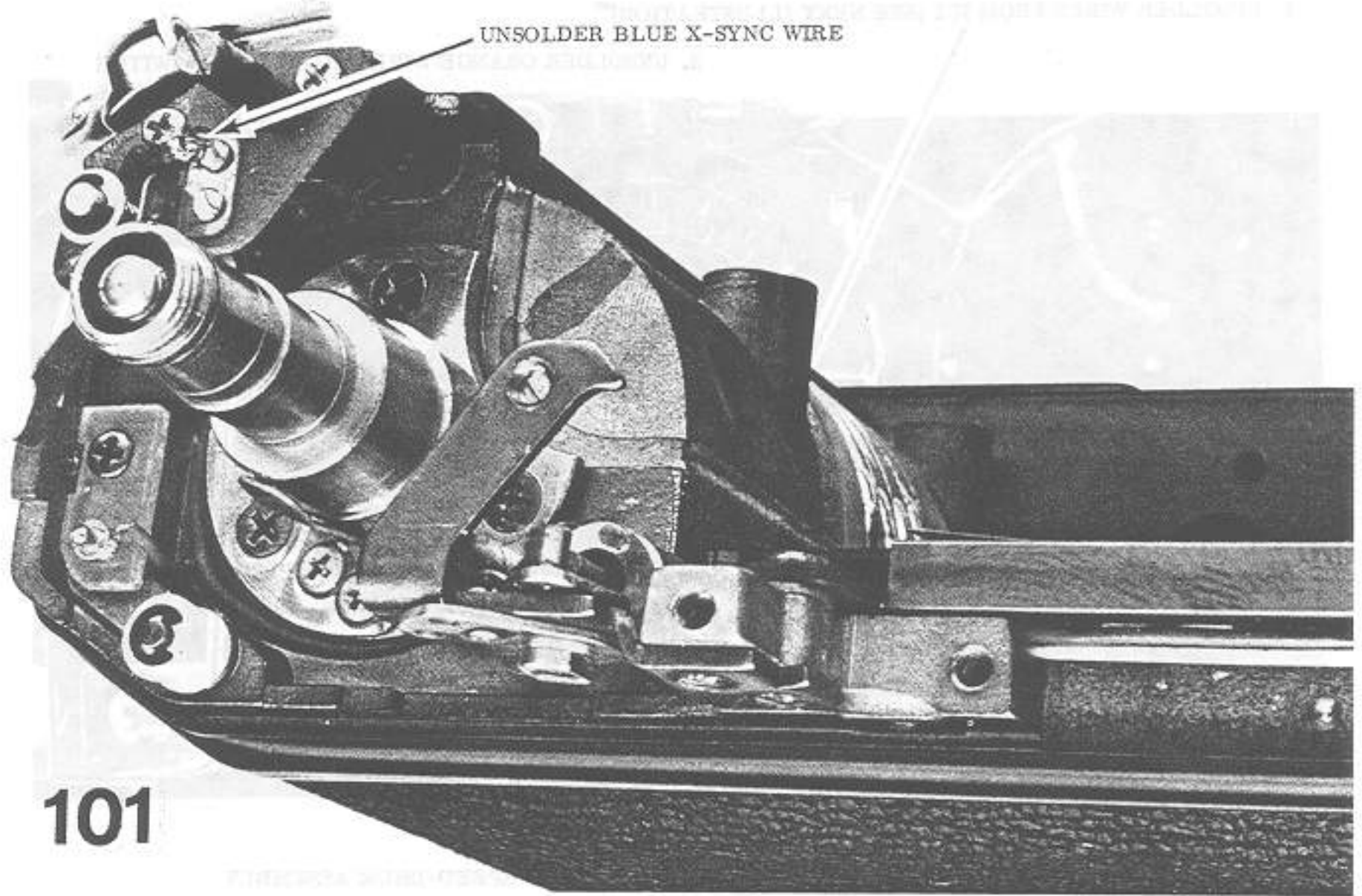

101

1. UNSOLDER WIRES FROM IC1 (SEE NEXT ILLUSTRATION)

2. UNSOLDER ORANGE WIRE FROM ON-OFF SWITCH

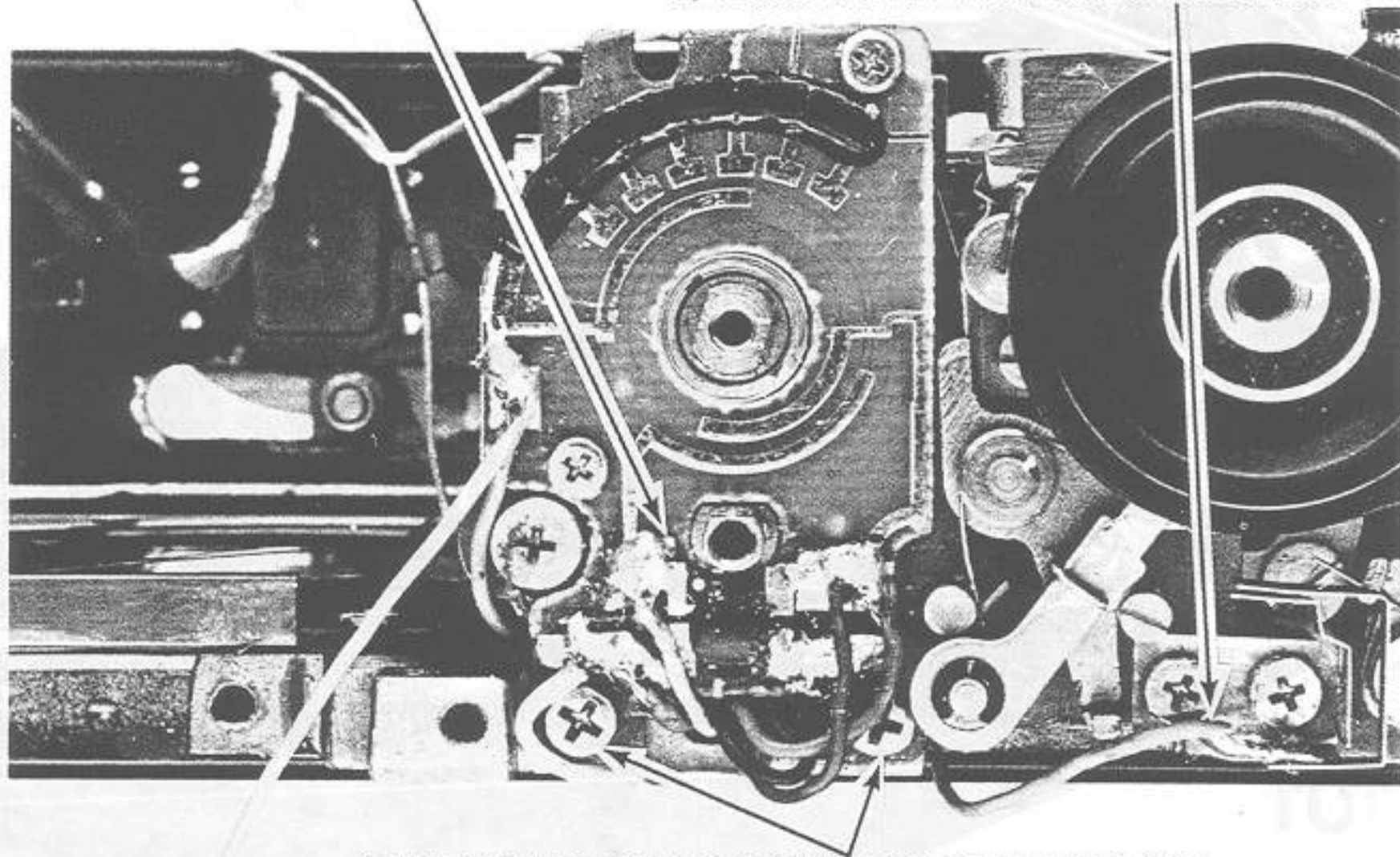

3. REMOVE TWO SCREWS AND LIFT OUT SPEED-DRUM ASSEMBLY

**102**

NOTE: SPEED SELECTOR DOES NOT HAVE TO BE REMOVED - WE'VE REMOVED IT HERE FOR ILLUSTRATION PURPOSES

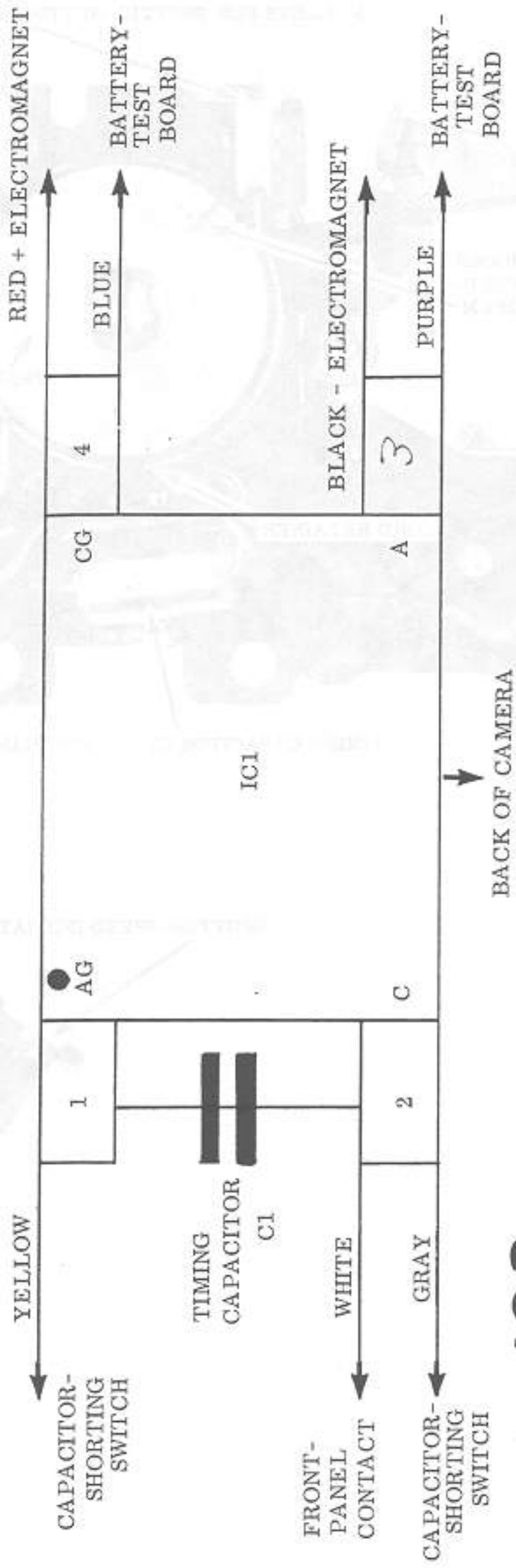

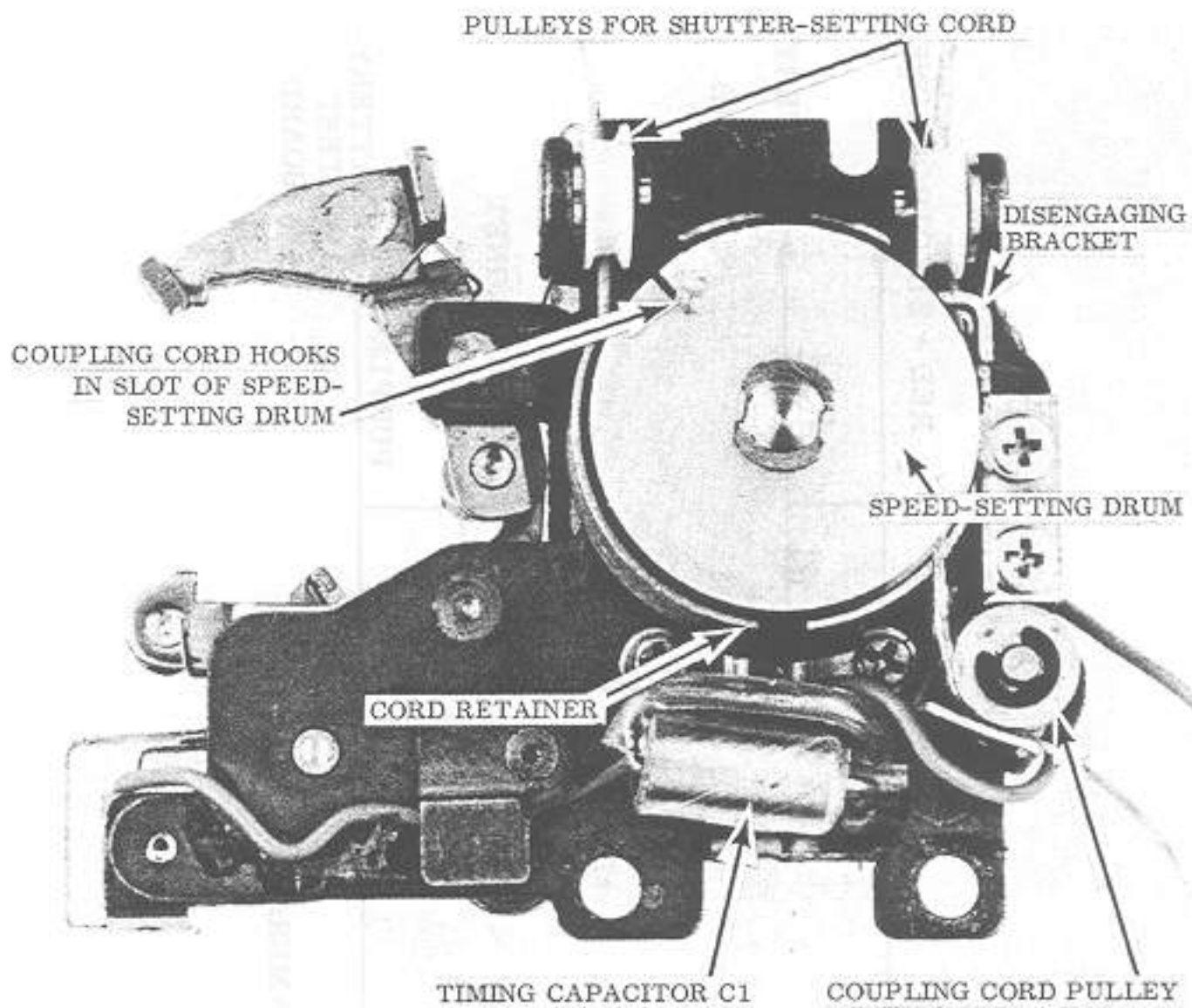

SHUTTER-SPEED INDICATOR

104



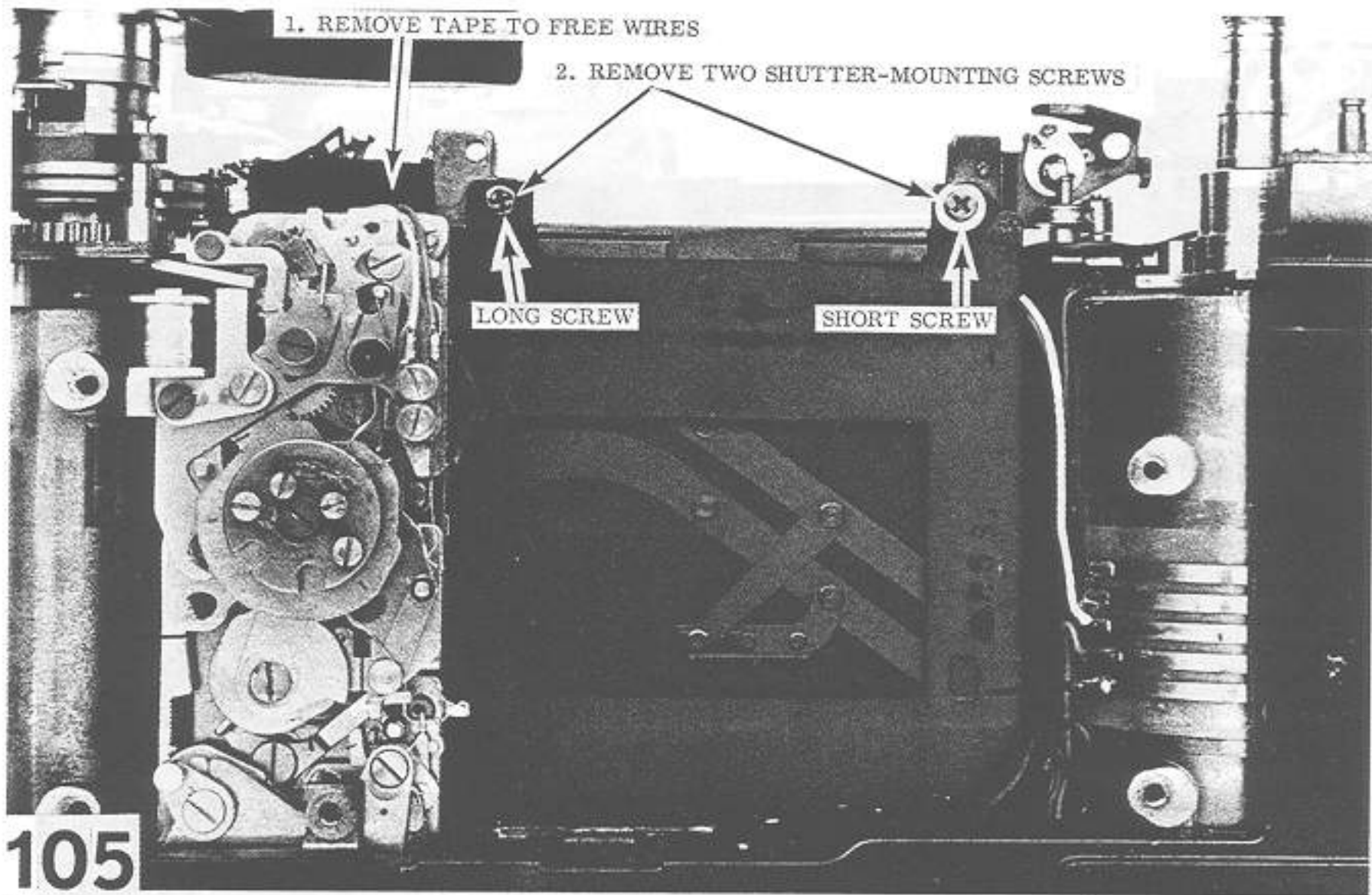

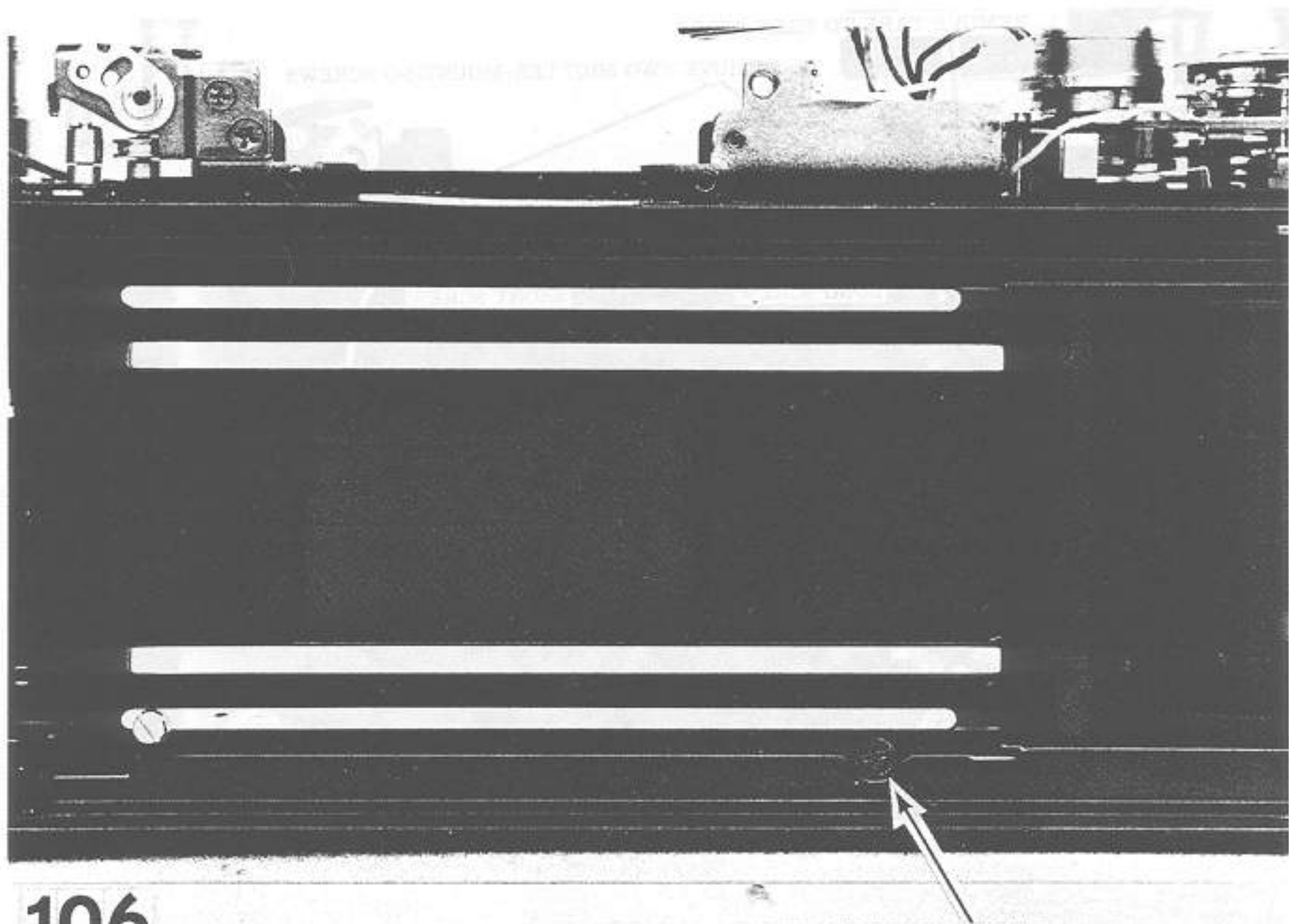

**106**

REMOVE REAR SHUTTER-MOUNTING SCREW

WIRE FROM CLOSING-BLADE  
OF MIRROR-RETURN POST  
LINK HOOKS IN HOLE

107

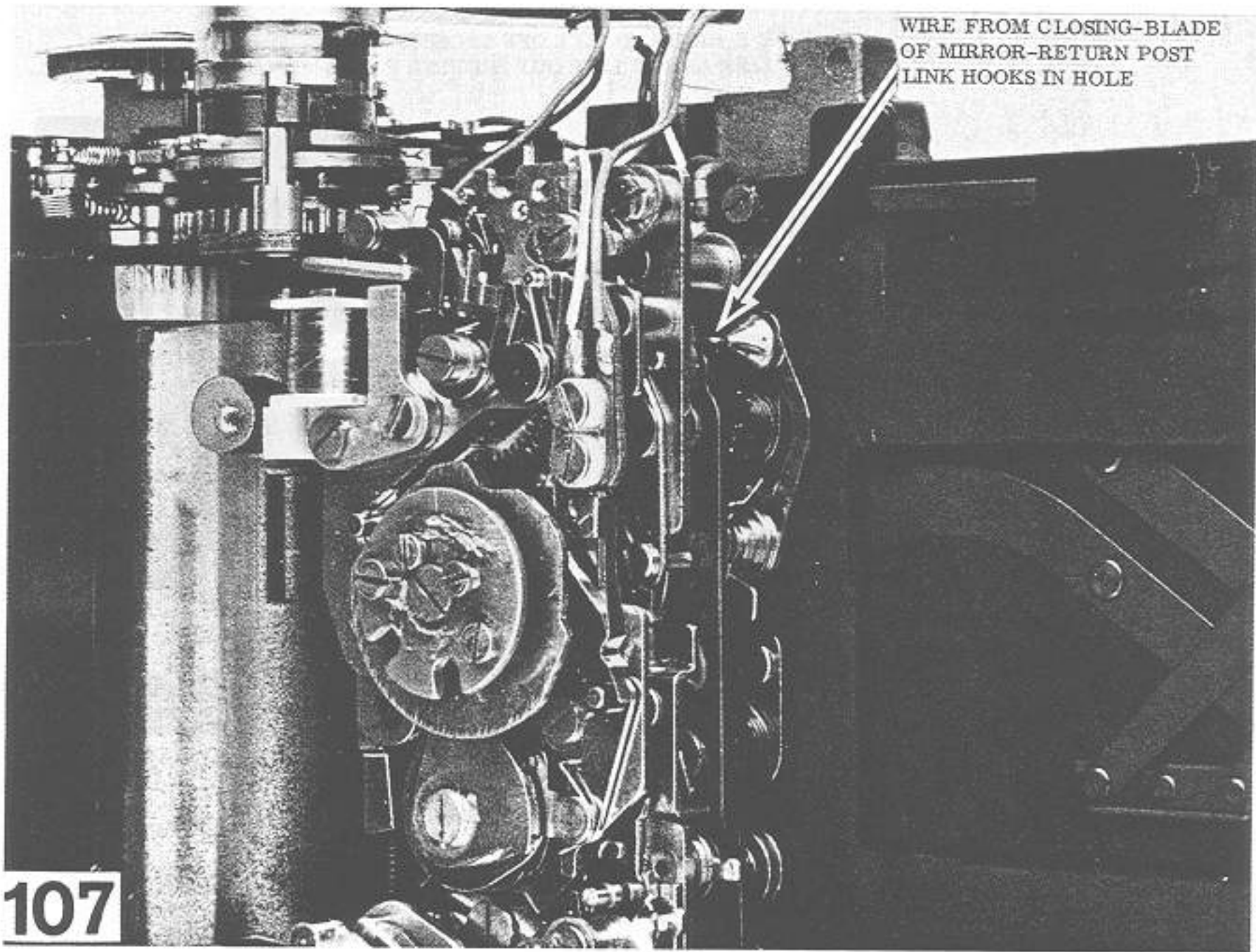

REMOVE E-RING AND LIFT OFF CLOSING-BLADE  
LINK AS YOU LIFT OUT SHUTTER

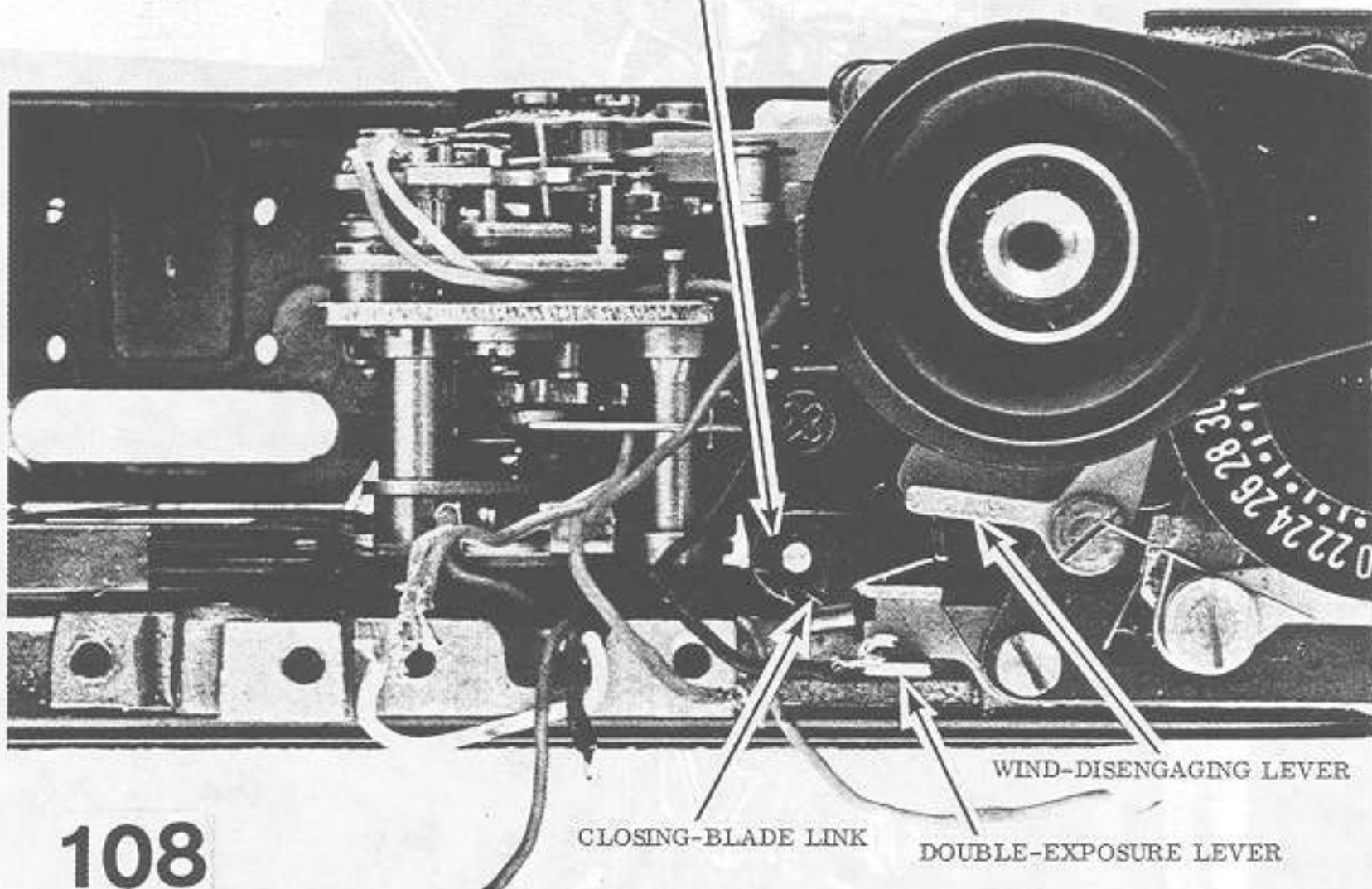

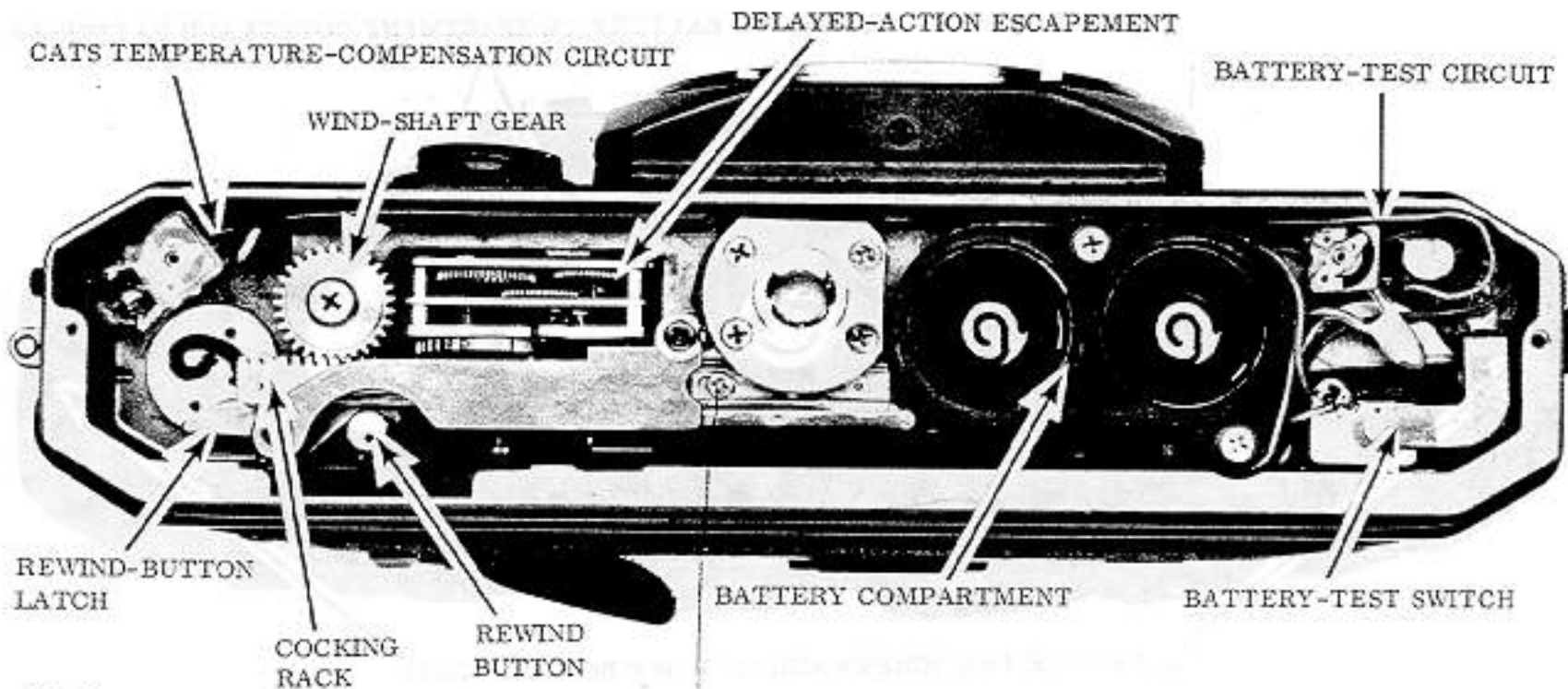

10

adjustment for overtravel or undertrip  
(cocking)

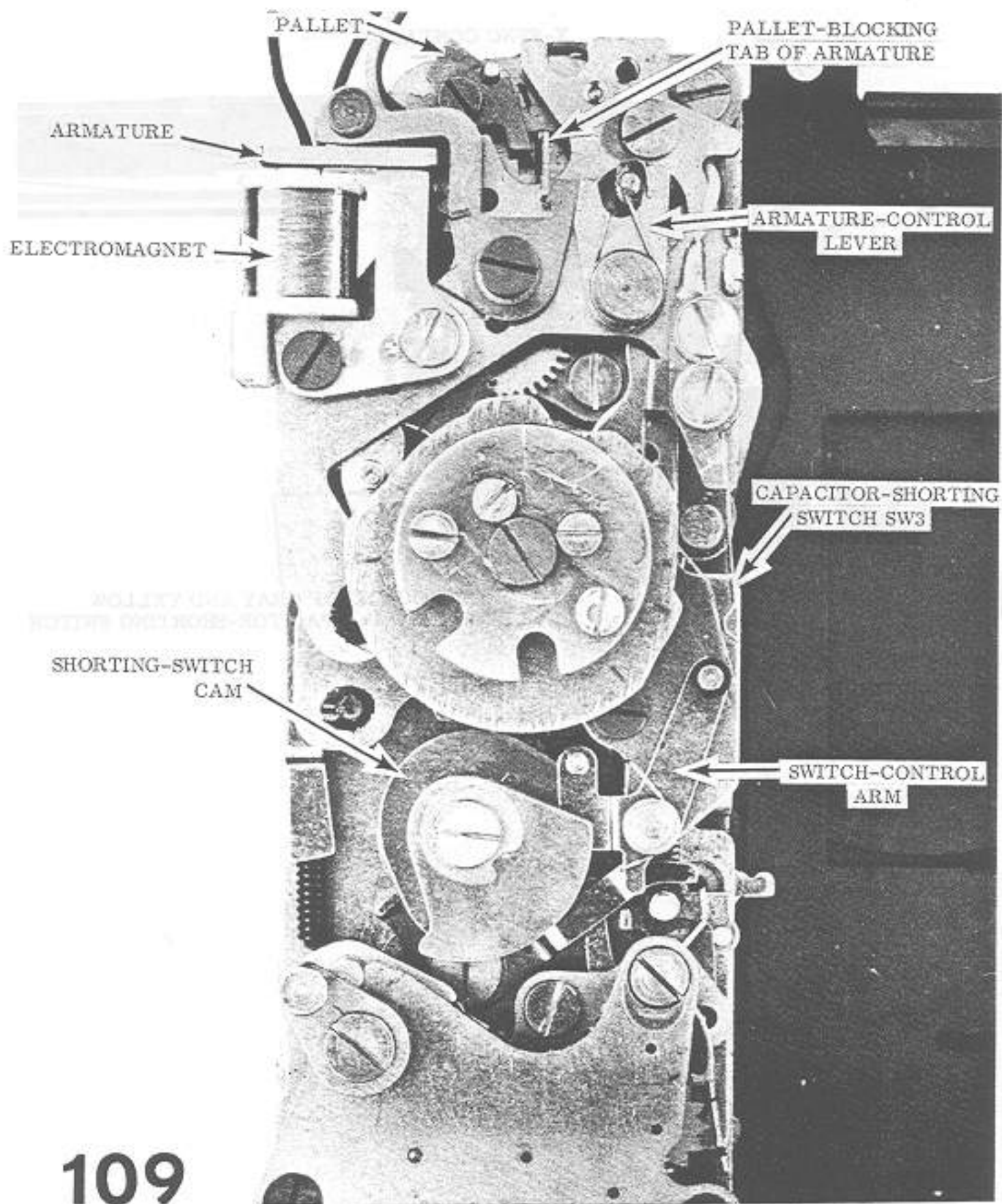

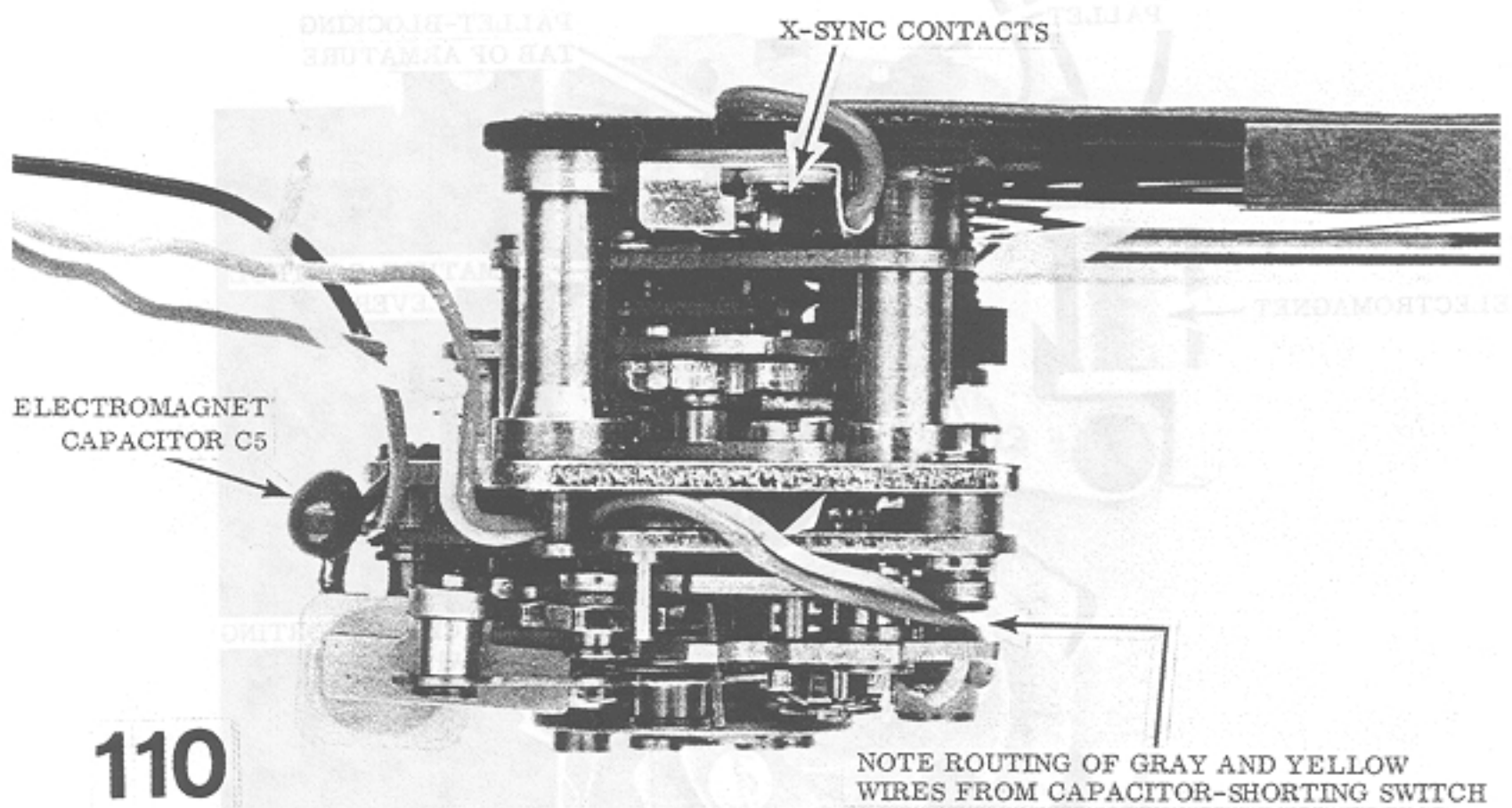

110

*Modification*

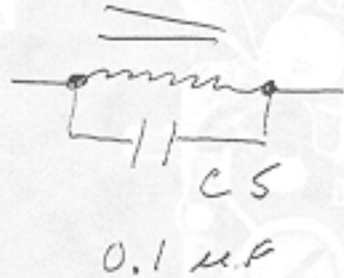

ENGAGEMENT OF COCKING RACK WITH  
WIND-SHAFT GEAR -- 7 1/2 TO 8 TEETH

LEFT-HAND SCREW

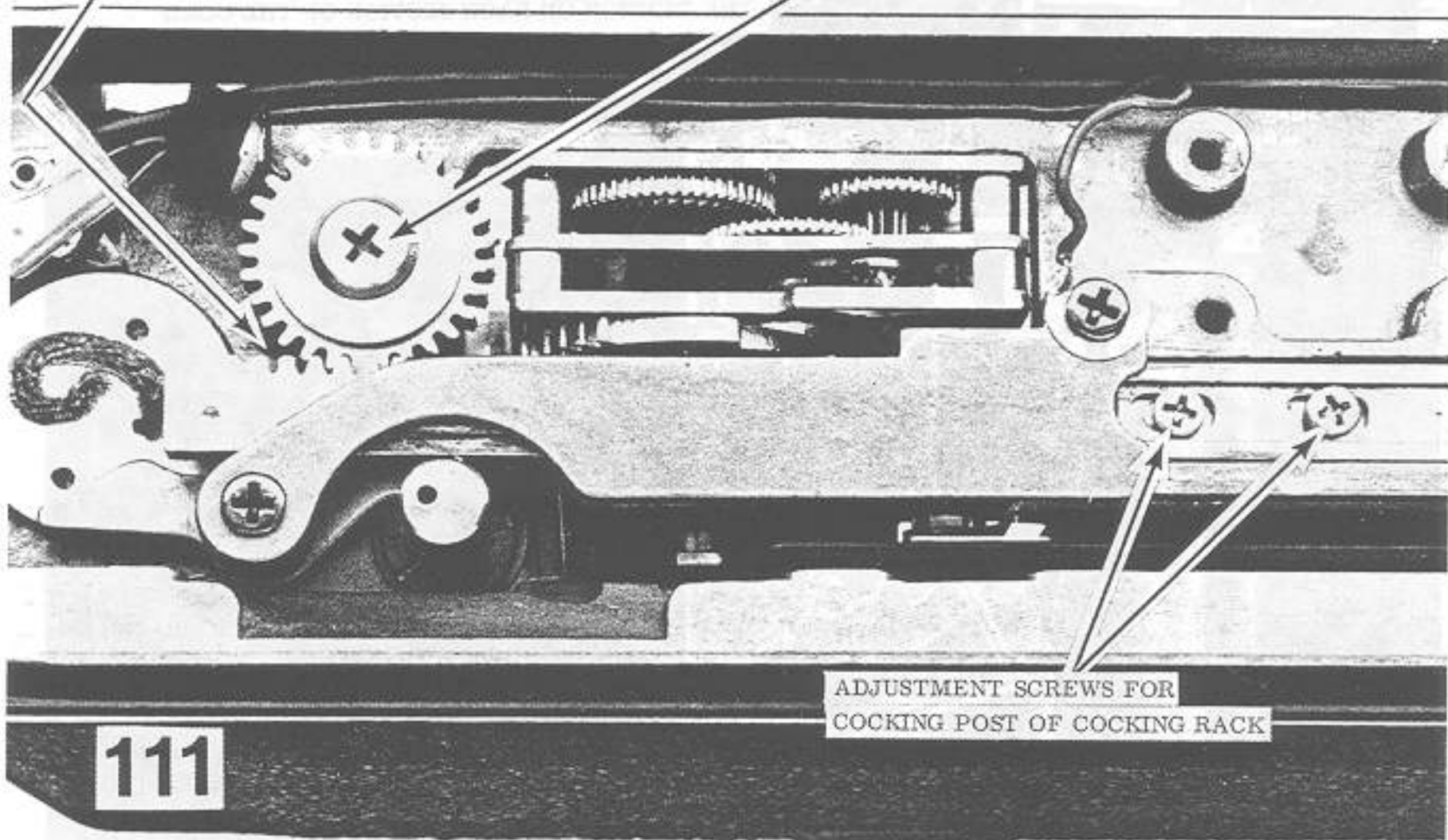

ADJUSTMENT SCREWS FOR  
COCKING POST OF COCKING RACK

111

*if shutter doesn't cock or advance won't come  
back Take off left hand screws, take off  
gear + replace 180° make 1/2 tooth adjustment*

REATTACH THE TWO ENDS OF THE SPEED-SETTING  
CORD; THEN, USE THE ECCENTRICS TO EQUALIZE  
THE TENSION ON EACH SECTION OF THE CORD

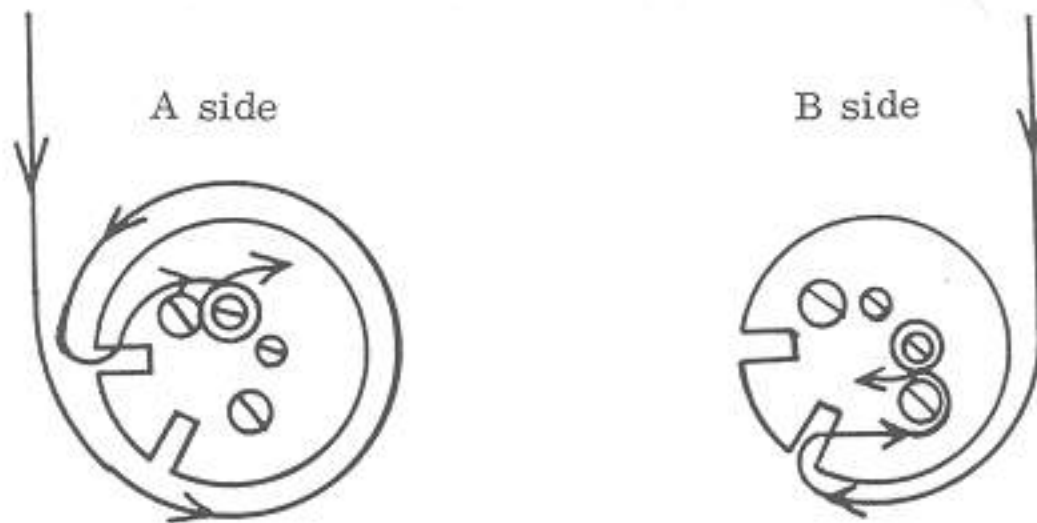
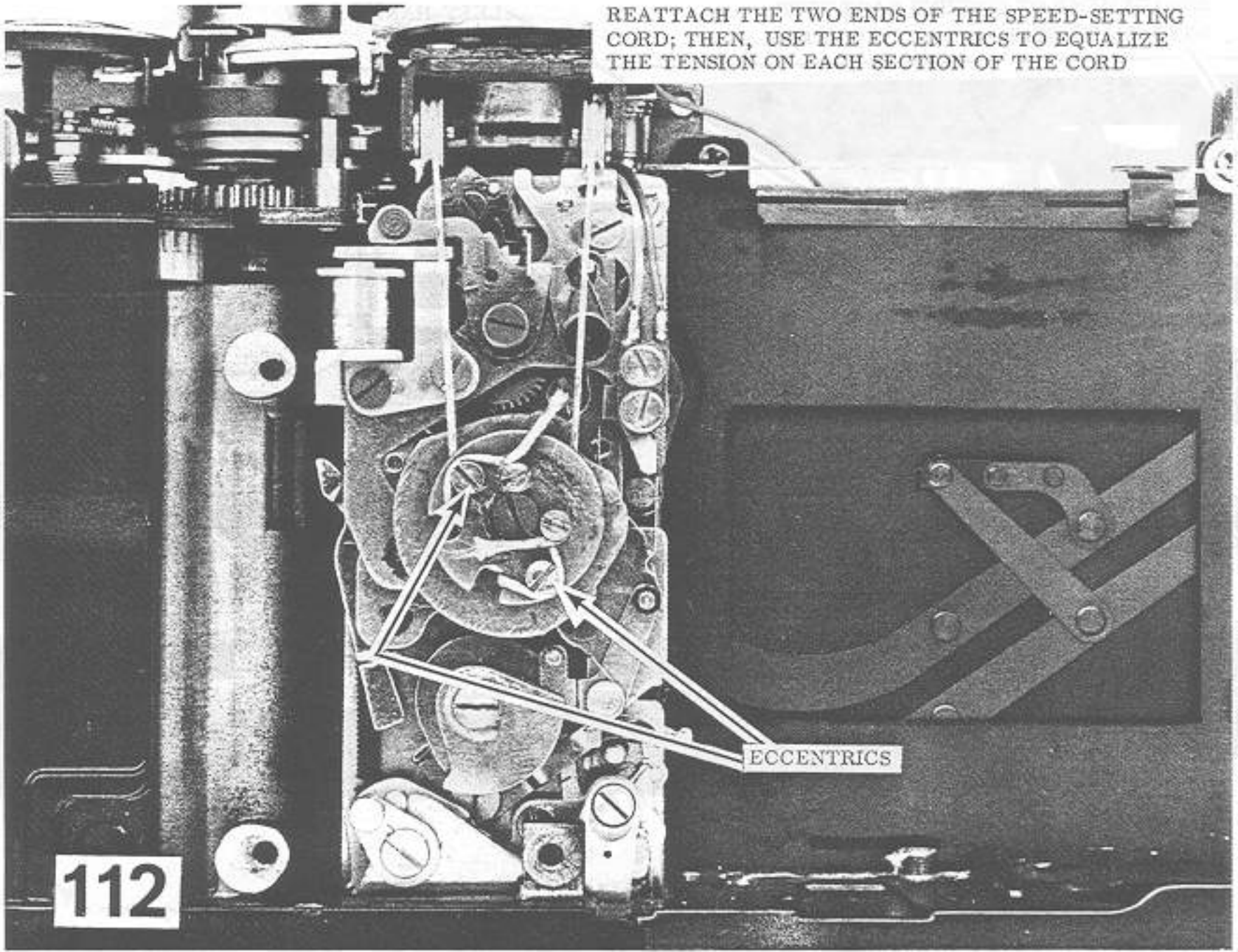

*Set at level*

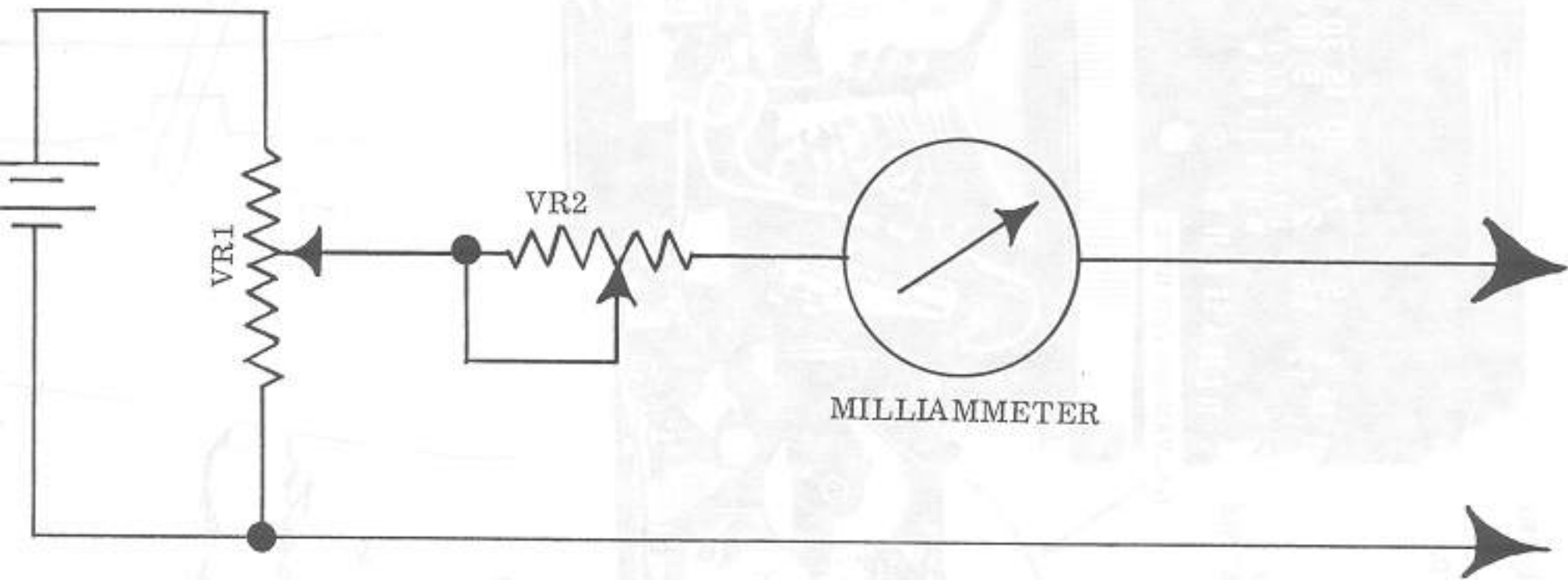

113

APERTURE-SCALE ADJUSTMENT:

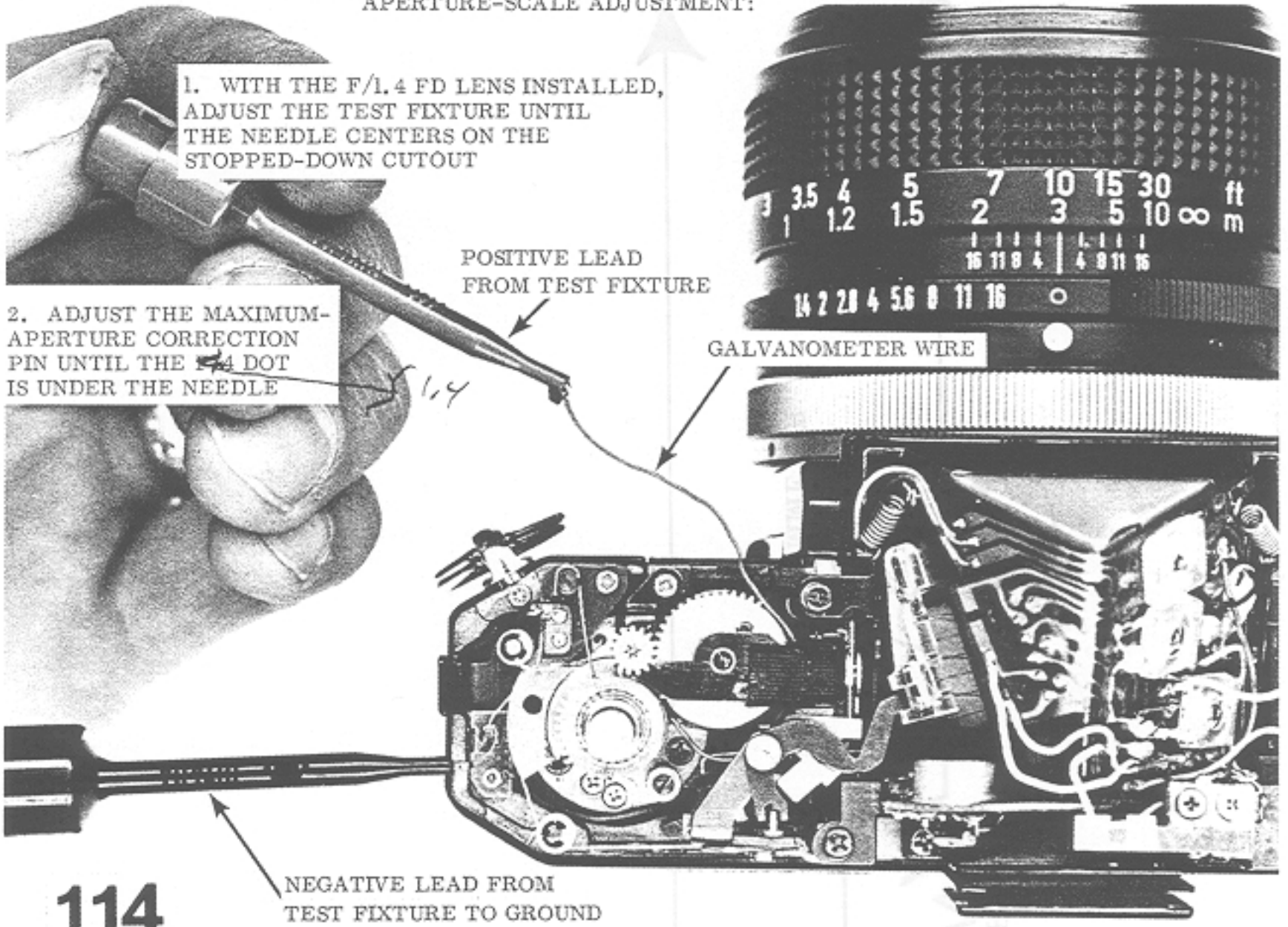

114

1. WITH THE F/1.4 FD LENS INSTALLED, ADJUST THE TEST FIXTURE UNTIL THE NEEDLE CENTERS ON THE STOPPED-DOWN CUTOUT

2. ADJUST THE MAXIMUM-APERTURE CORRECTION PIN UNTIL THE ~~F/4~~ DOT IS UNDER THE NEEDLE

POSITIVE LEAD FROM TEST FIXTURE

GALVANOMETER WIRE

NEGATIVE LEAD FROM TEST FIXTURE TO GROUND

- 1. adjust aperture scale ↑
- (115) - 2. " maximum aperture ×
- (116) - 3. position of metering sector
- (117) } 4. mount film speed gear unit
- (118) }
- (119) }
- (120) - 5 - adjust meter
- (121) - 6 " cats circuit
- (122) - 7 " diaphragm opening

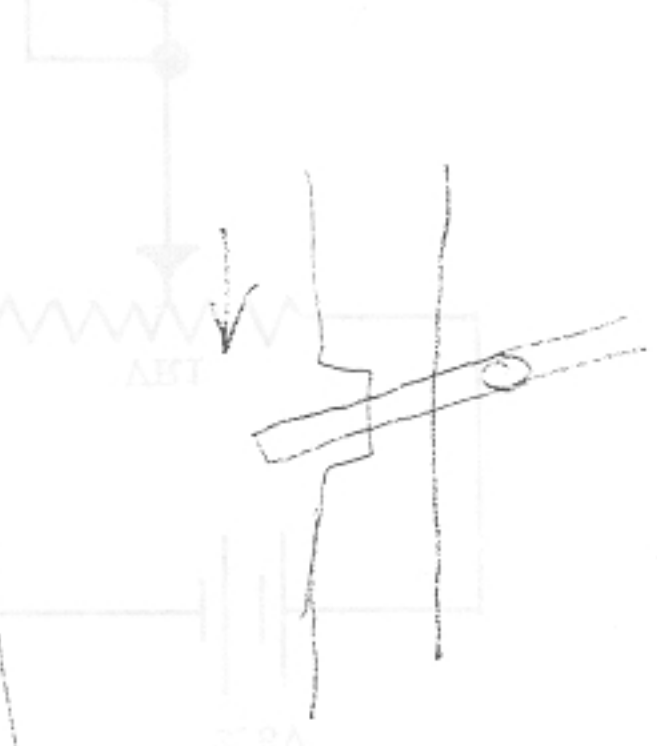

Scale would  
be low when  
you turn pin  
clockwise

MAXIMUM-APERTURE ADJUSTMENT:

WITH F/2.8 FD LENS INSTALLED,  
MAXIMUM-APERTURE CORRECTION  
LEVER SHOULD JUST TOUCH  
CORD-CONTROL LEVER -- MAXIMUM-  
APERTURE CORRECTION LEVER MOVES  
AWAY FROM CORD-CONTROL LEVER  
WHEN YOU INSTALL F/1.4 FD LENS  
(AS SHOWN); MAKE ADJUSTMENT WITH  
ECCENTRIC

MAXIMUM-APERTURE  
CORRECTION LEVER

ECCENTRIC

CORD-CONTROL LEVER

115

*adjust maximum aperture*

*lens on sub for 2.8 lens*

*lens off*

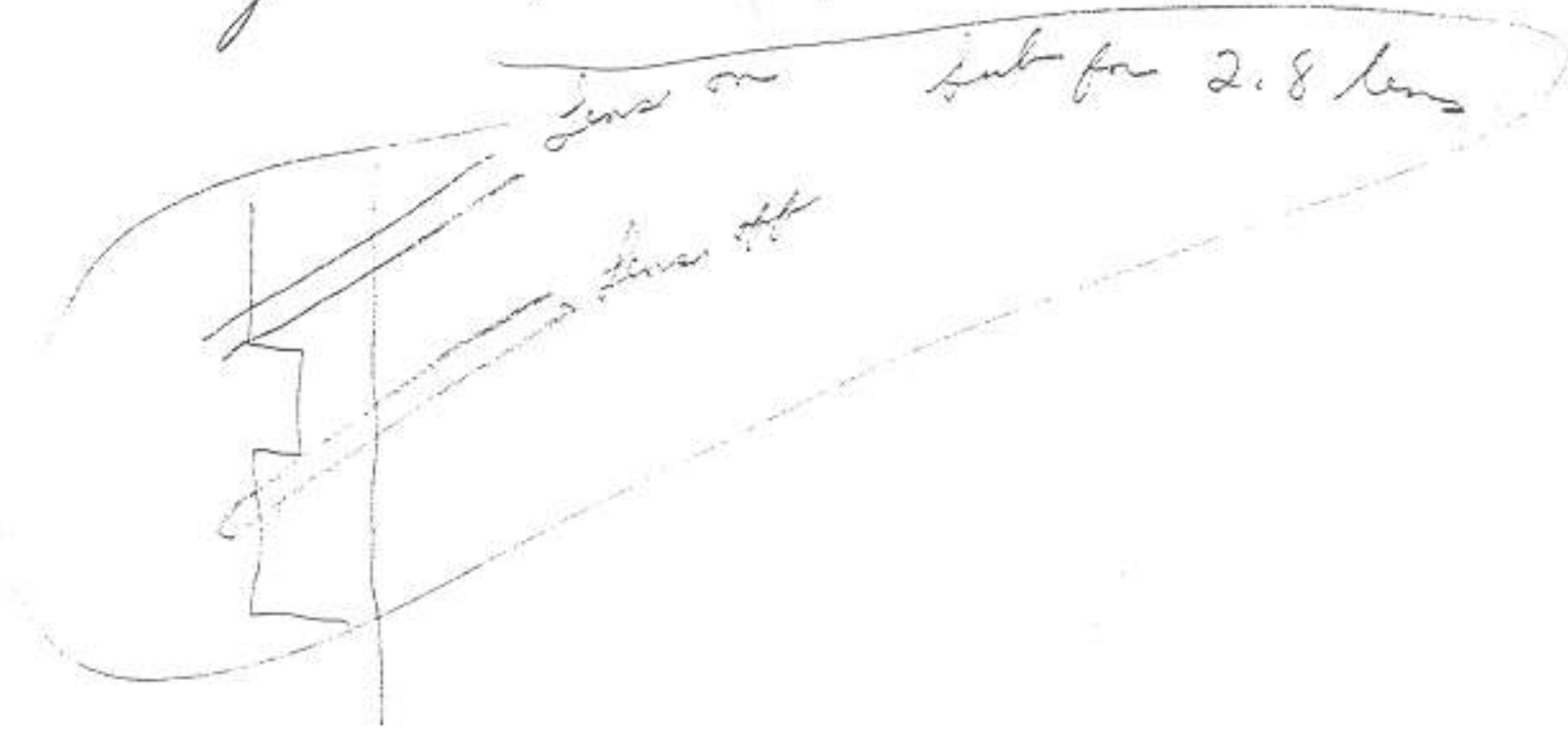

ADJUSTMENT OF METERING-SECTOR POSITION:

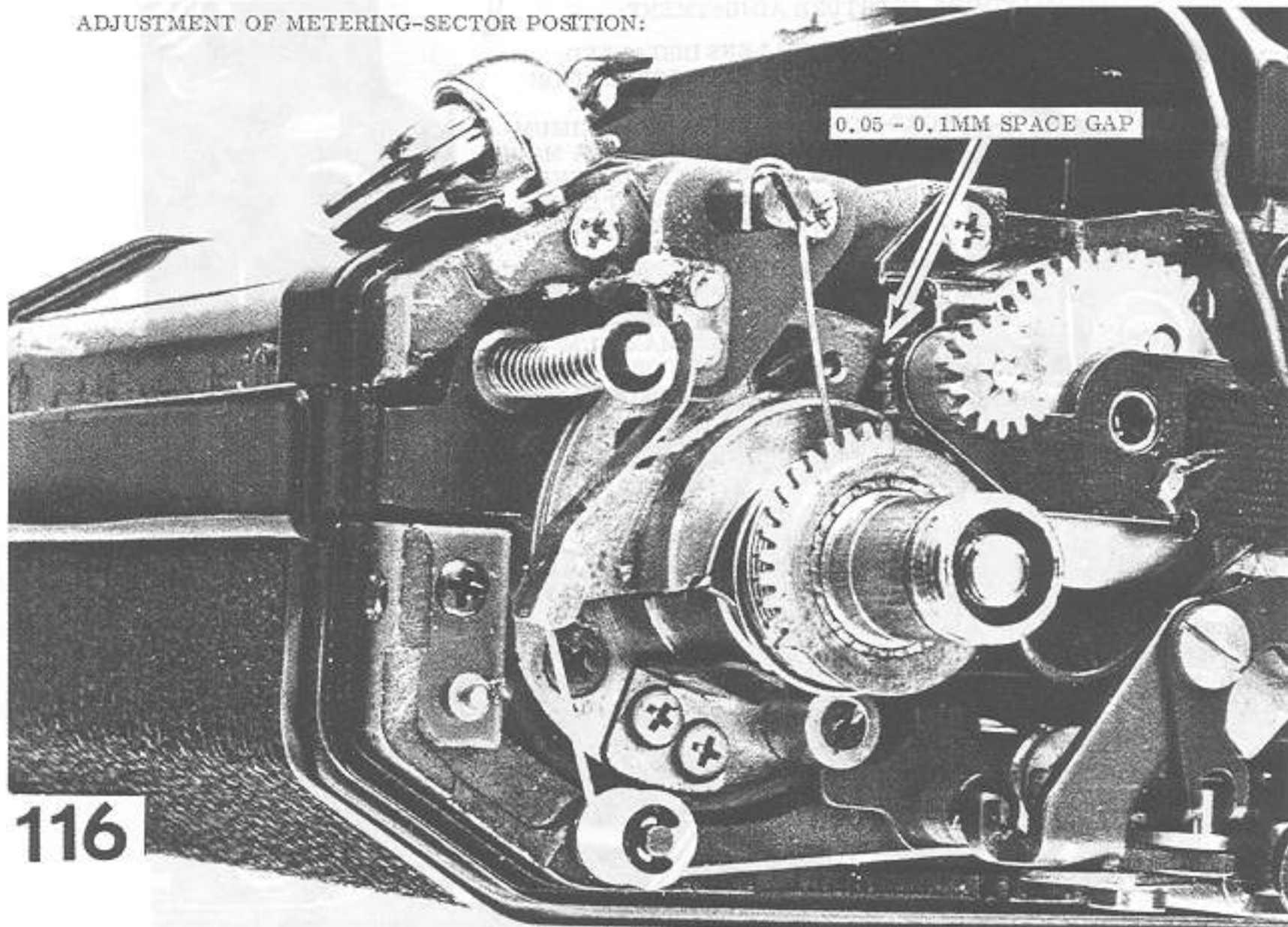

116

WITH THE SHUTTER SET TO "BULB," ADJUST THE POSITION OF THE METERING SECTOR WITH THE COUPLING CORD

*adjust position of metering sector*

MOUNTING OF FILM-SPEED  
GEAR UNIT (1)

SET TEST FIXTURE FOR 294  
MICROAMPERES AND CENTER  
NEEDLE IN STOPPED-DOWN  
CUTOUT BY TURNING  
GALVANOMETER HOUSING

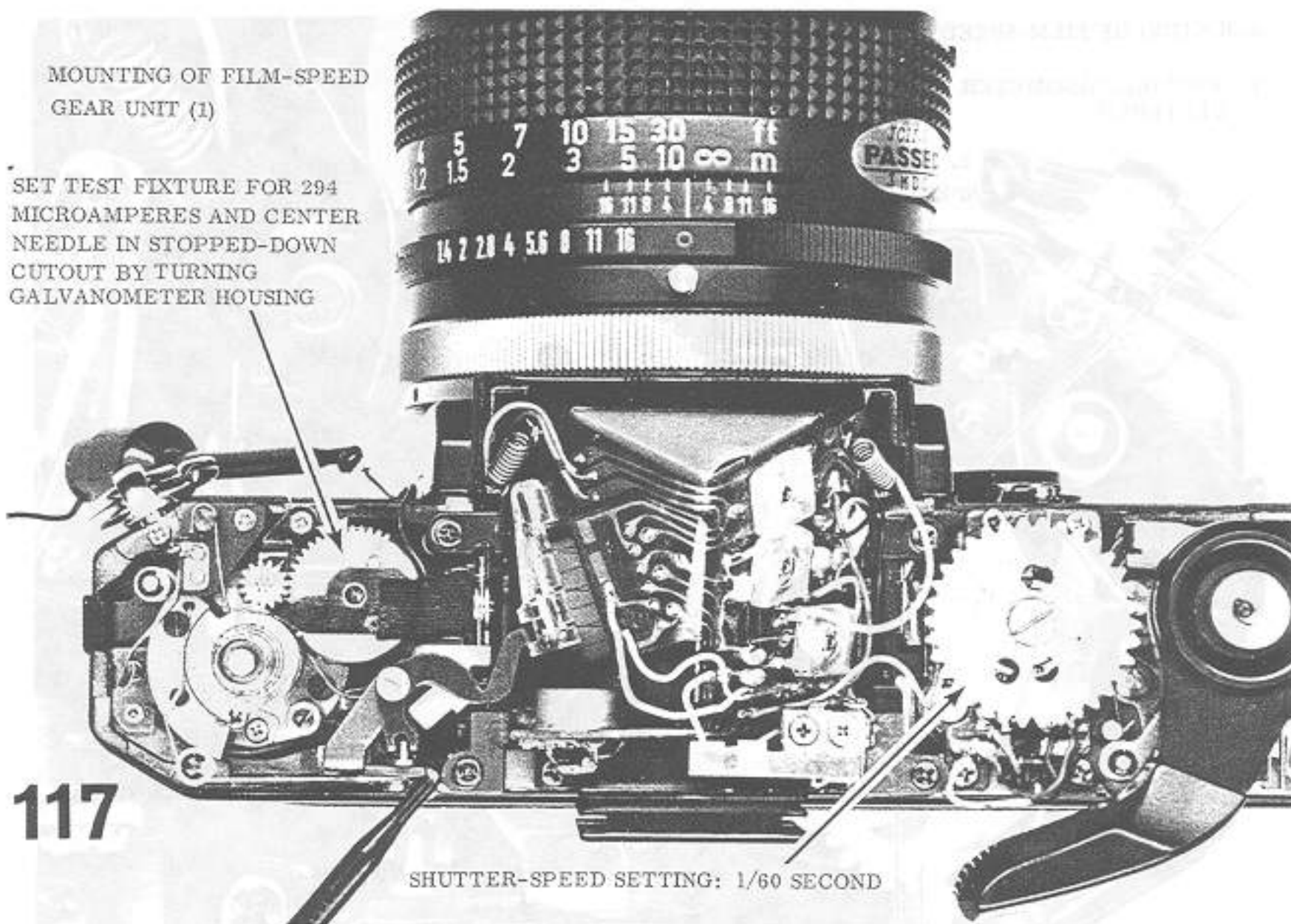

SHUTTER-SPEED SETTING: 1/60 SECOND

*Mount film speed gear unit*

MOUNTING OF FILM-SPEED GEAR UNIT (2)

1. HOLD GALVANOMETER IN POSITION WITH NEEDLE CENTERED

2. INSTALL FILM-SPEED GEAR UNIT

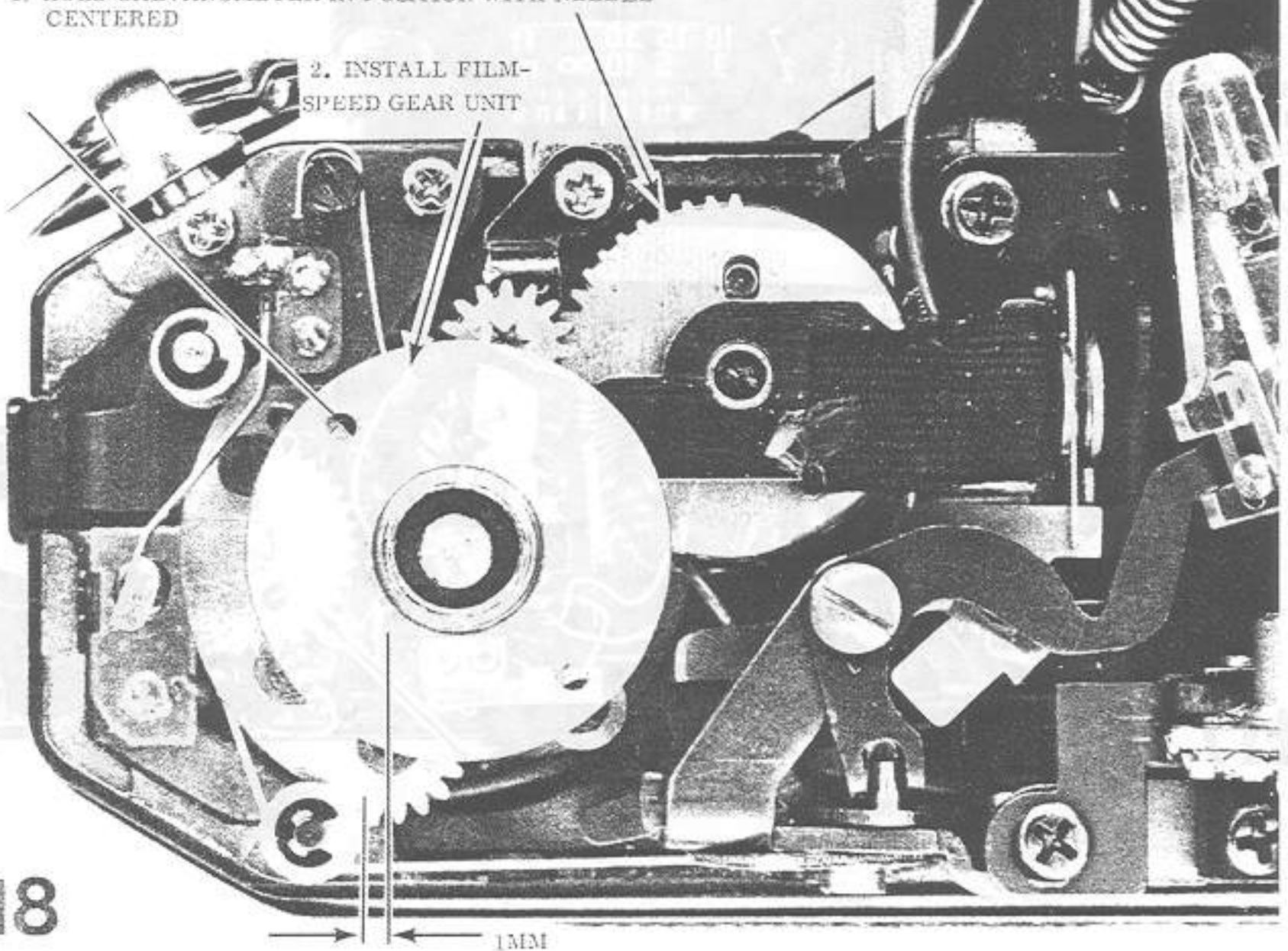

118

*Mount film speed gear unit*

*See also 113 & 114  
12 30 sec*

# BASIC LED CIRCUIT

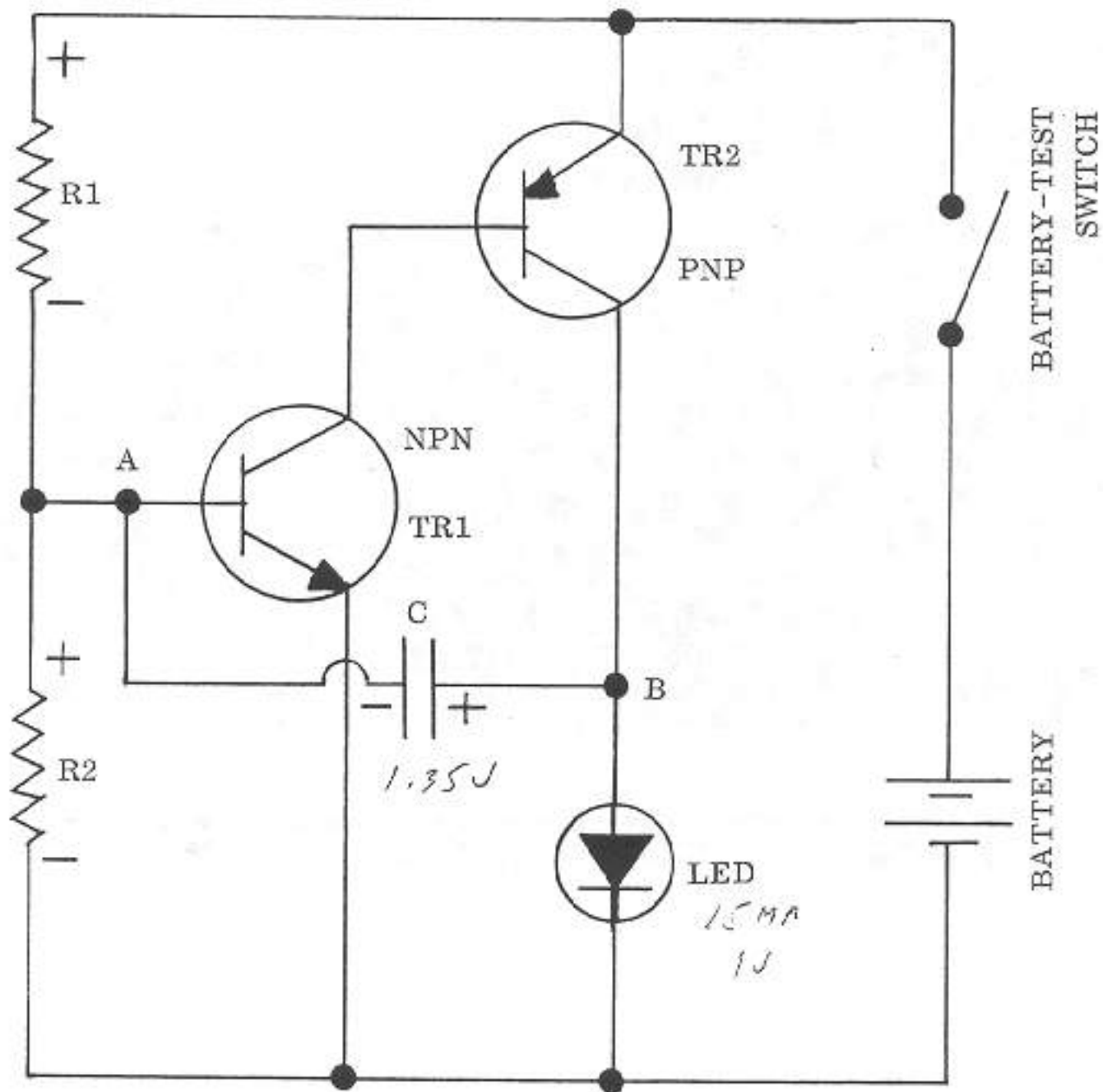

11

on-off Rates (1)

Current drawn - 1.9 MA

MOUNTING OF FILM-SPEED GEAR UNIT (3)

1. REPLACE FILM-SPEED COUPLER WITH TAB  
FACING FRONT OF CAMERA

2. INSTALL SPECIAL TOOL  
TO HOLD ASA 100 POSITION

3. RESOLDER GALVANOMETER WIRE

119

*Mount film speed gear unit*

METER ADJUSTMENT:

ADJUST THE EXPOSURE  
WITH VR2 AND VR4

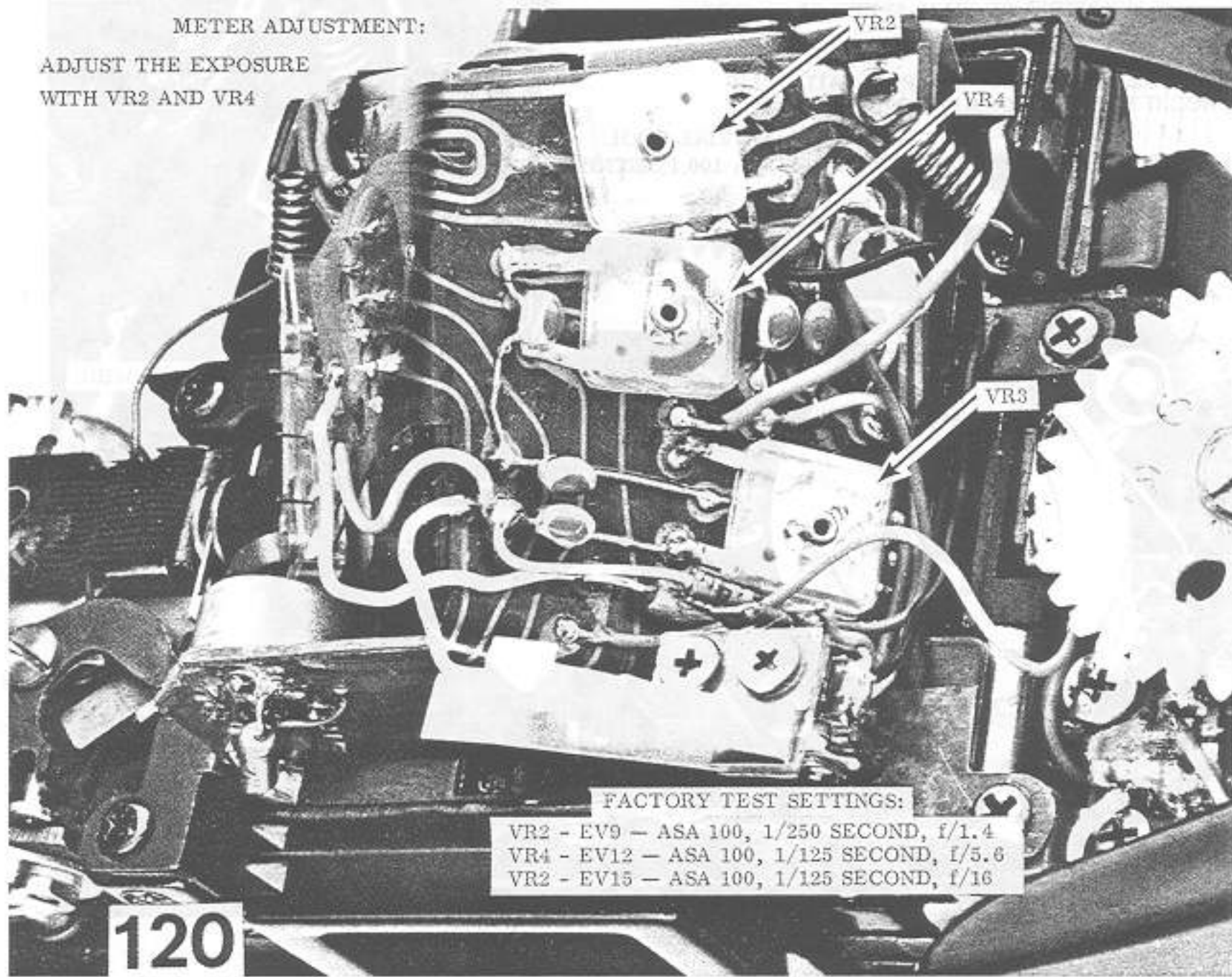

FACTORY TEST SETTINGS:

VR2 - EV9 - ASA 100, 1/250 SECOND, f/1.4  
VR4 - EV12 - ASA 100, 1/125 SECOND, f/5.6  
VR2 - EV15 - ASA 100, 1/125 SECOND, f/16

120

# EQUIVALENT CIRCUIT - SPEEDLIGHT 133D

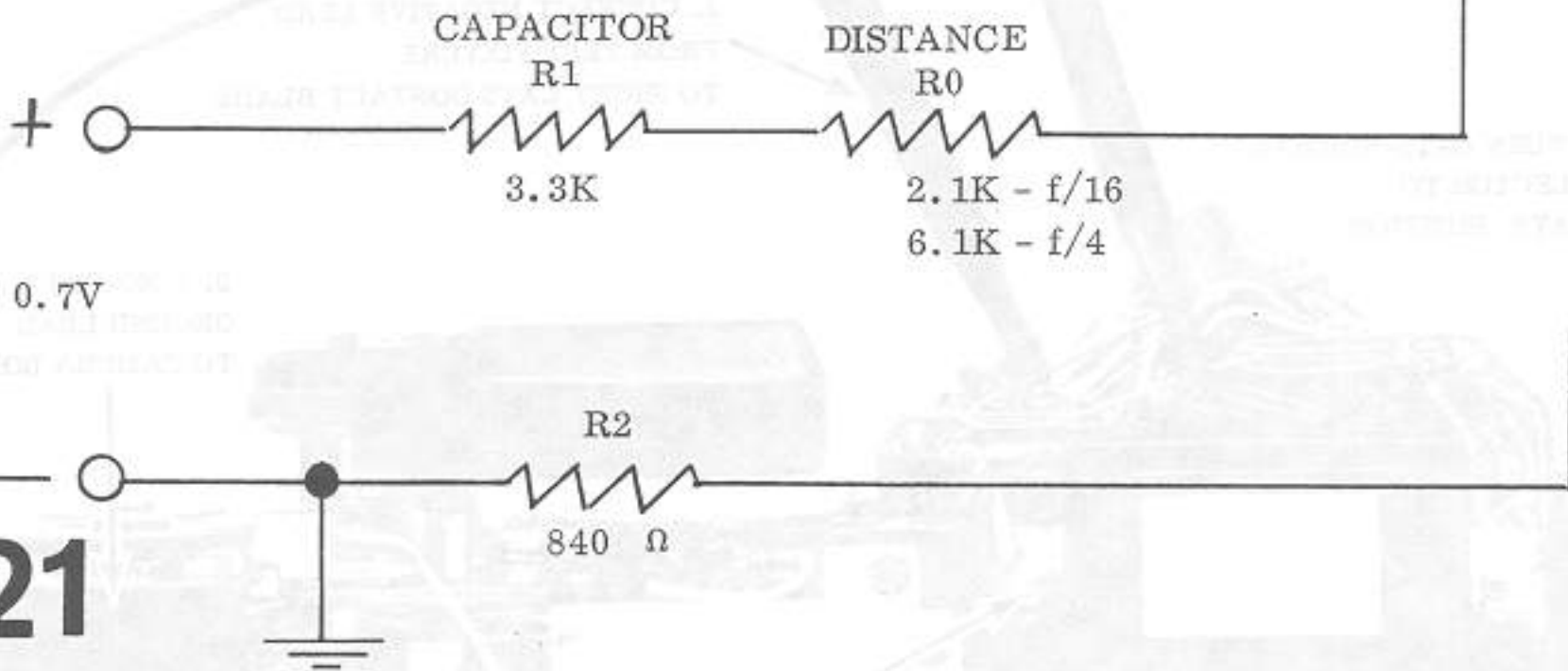
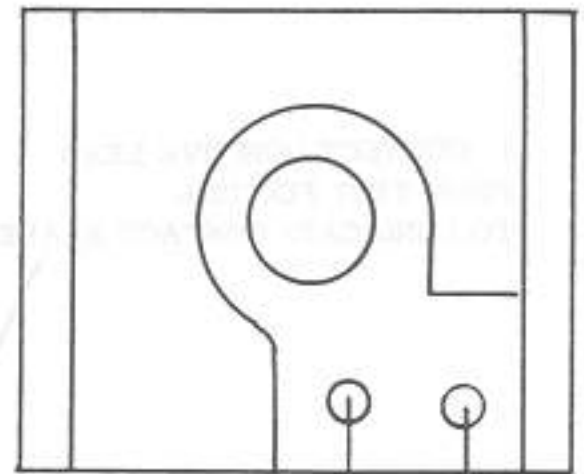

0.7V

121

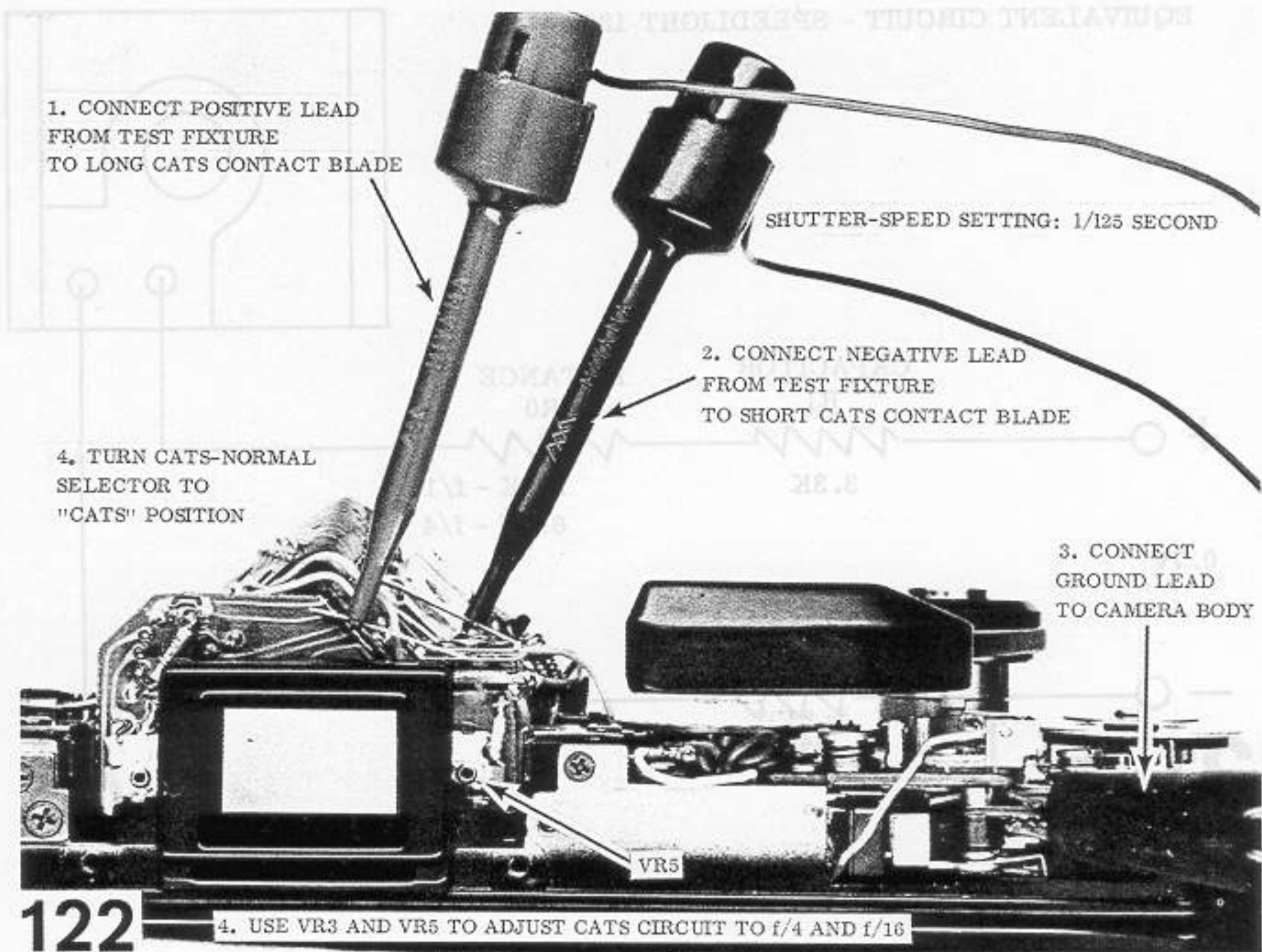

122

*adjust cats circuit*  
*VR3 - level adj. 54*  
*VR5 - slope adj. 510*

ADJUSTMENT OF DIAPHRAGM OPENING:

1. REMOVE THE CEMENTED COVER DISC OVER THE FOLLOWER-ECCENTRIC CLEARANCE HOLE

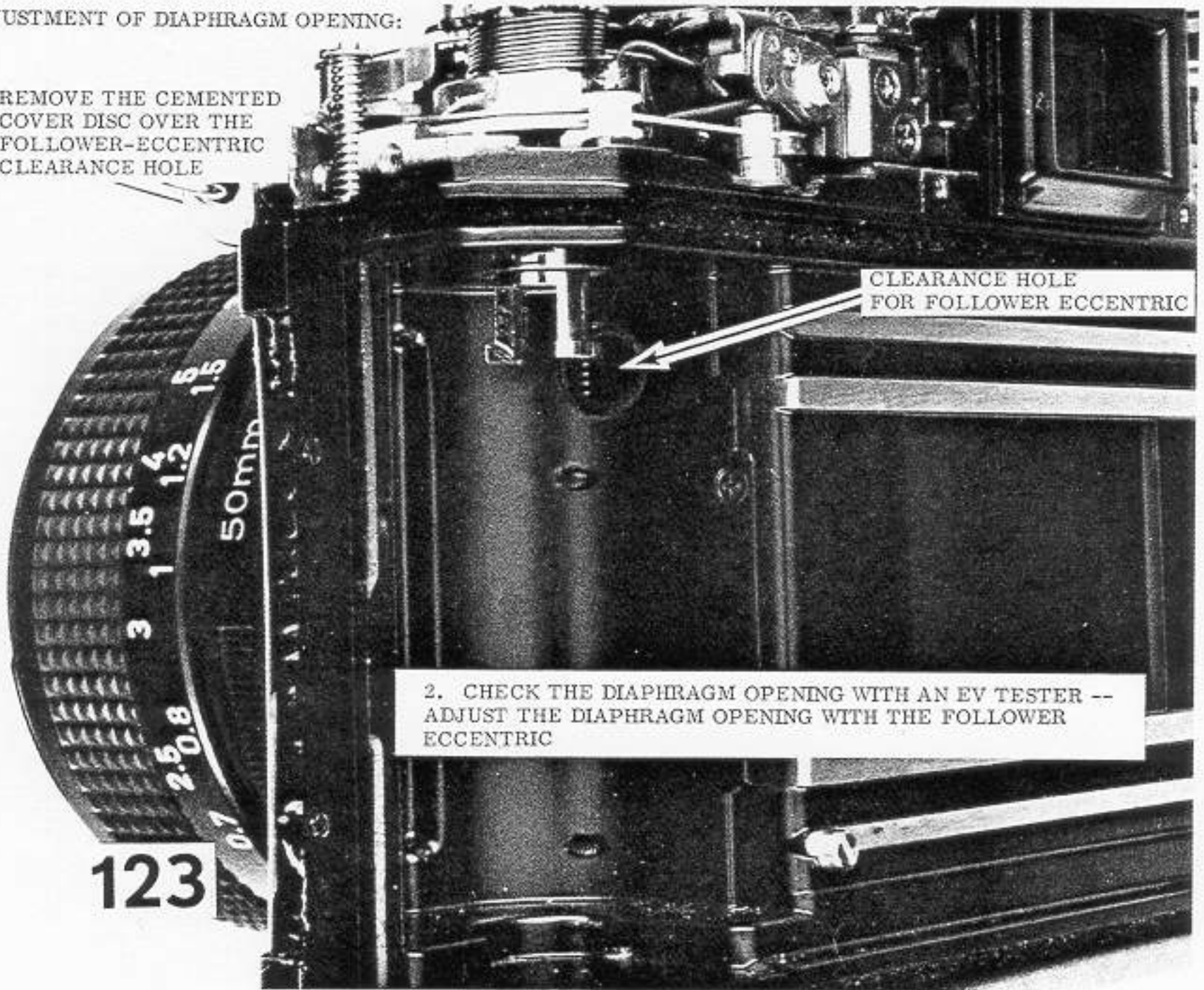

*adjust diaphragm opening*

*Check insulation on battery compartment*

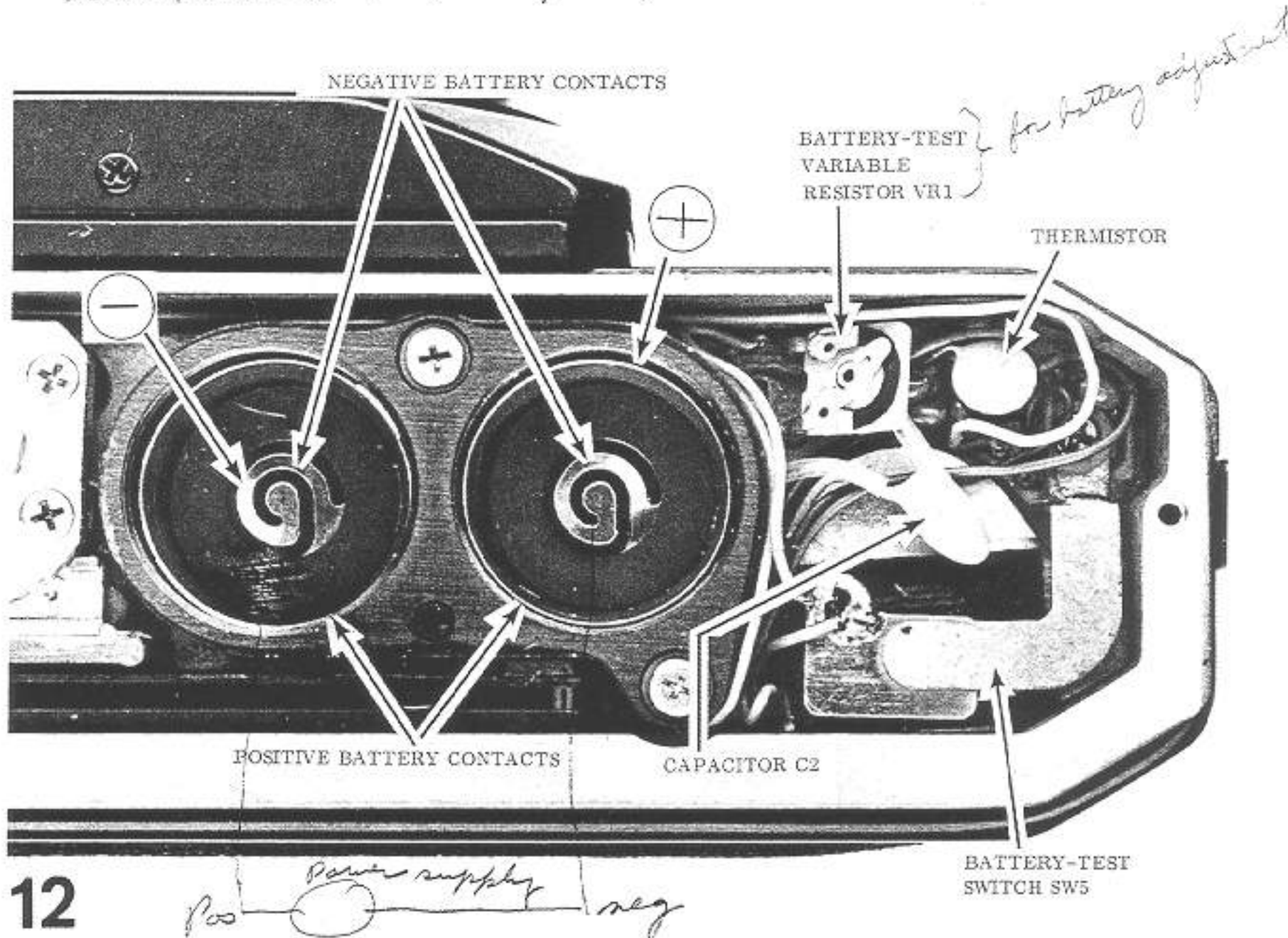

12

**BATTERY-TEST-CIRCUIT ADJUSTMENT:** Hook a DC power supply to the battery compartment as shown by the polarity indications. With the power supply set at 2.31 volts, the LED should operate when you close the battery-test switch; the LED should not operate at 2.26 volts. Make the adjustment with the battery-test variable resistor VR1.

*If battery runs down fast - Take off battery holder & tape underside (maybe shorted)*

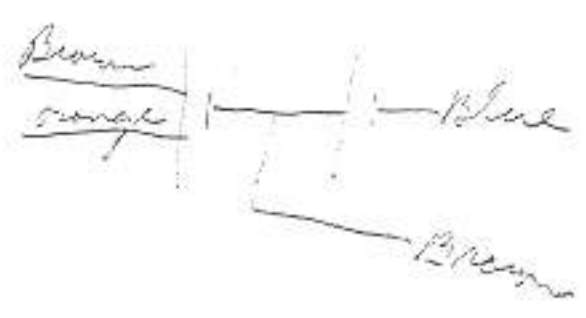
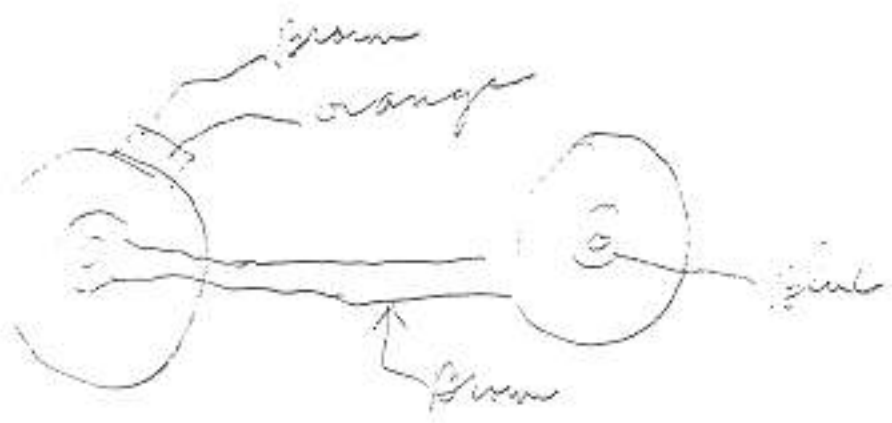

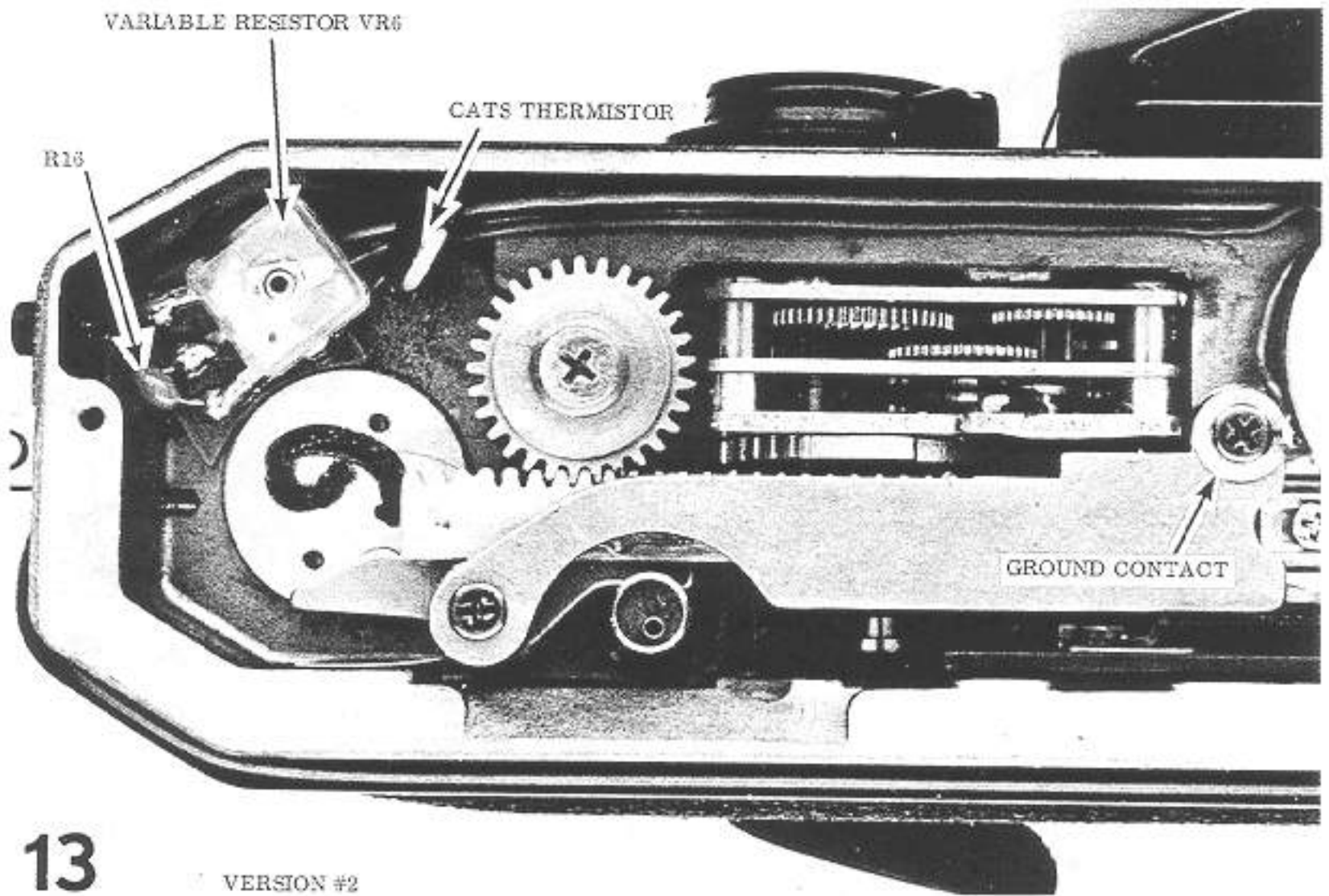

13

VERSION #2

The original Canon EF (version #1) does not have the CATS temperature-compensation circuit. The temperature-compensation circuit was added as a modification to the model illustrated (version #2). Later models (versions #3 and #4) have the thermistor and the fixed resistor at the top of the camera; in these cameras, the only part on the circuit board shown is the variable resistor VR6.

The red wire connects resistor VR6 to ground in the model illustrated. Later models use a screw to hold the VR6 circuit board. So the screw acts as a ground connection and eliminates the need for the red wire.

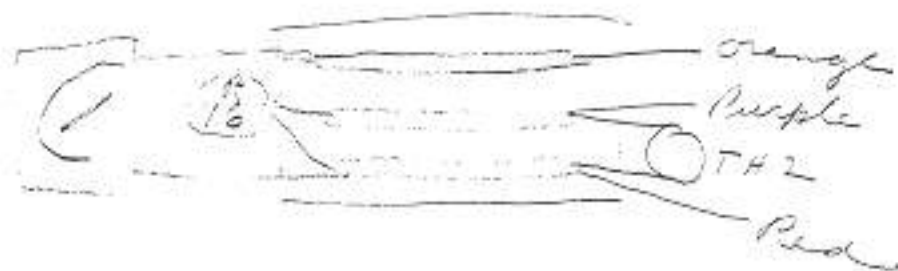

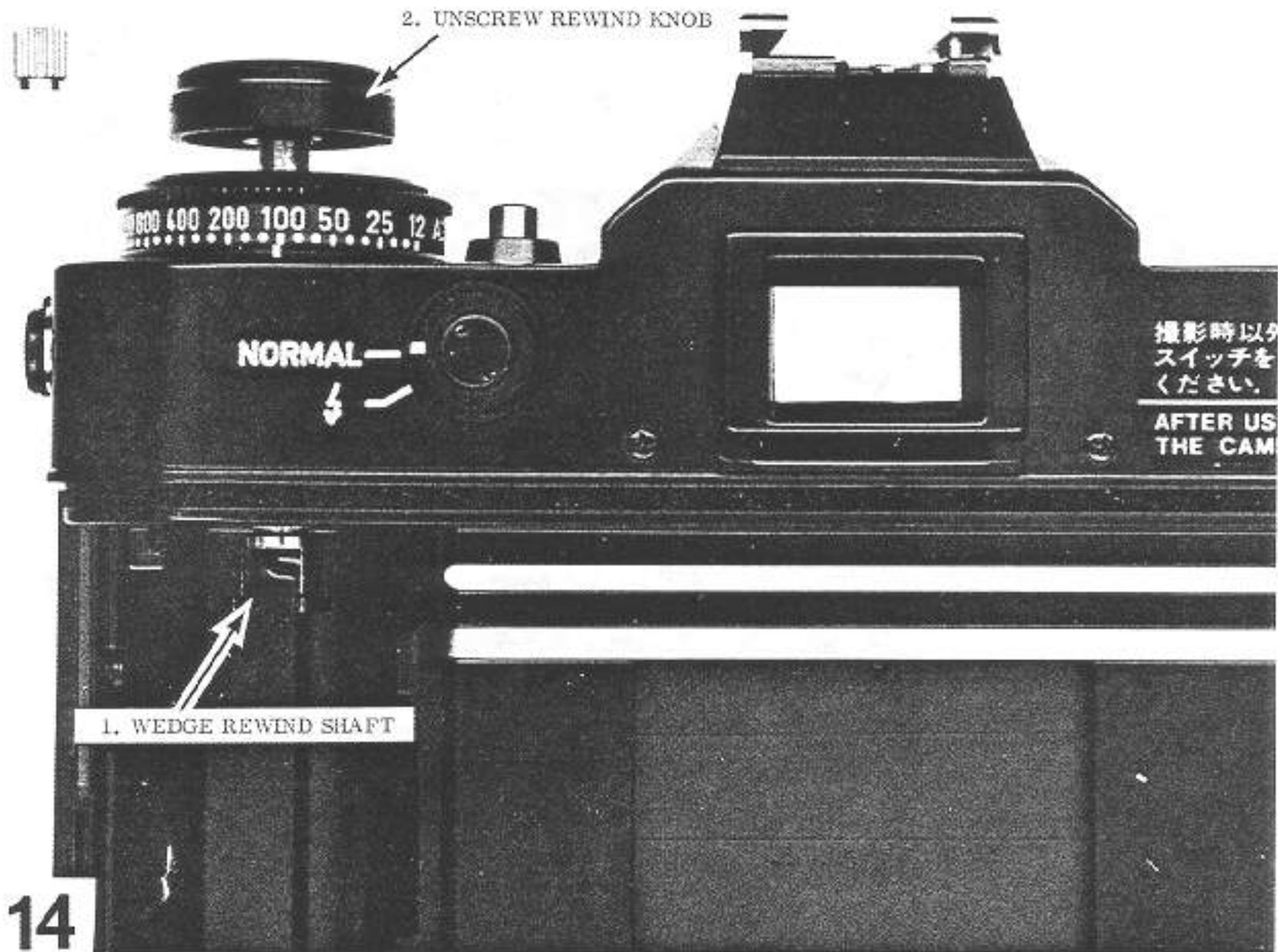

*Disassembly*

*ASA 100*

*BULB*

*on-off selector off*

1. UNSCREW RETAINING RING

2. LIFT OFF FILM-  
SPEED DIAL

CEMENTED COVER DISC

15

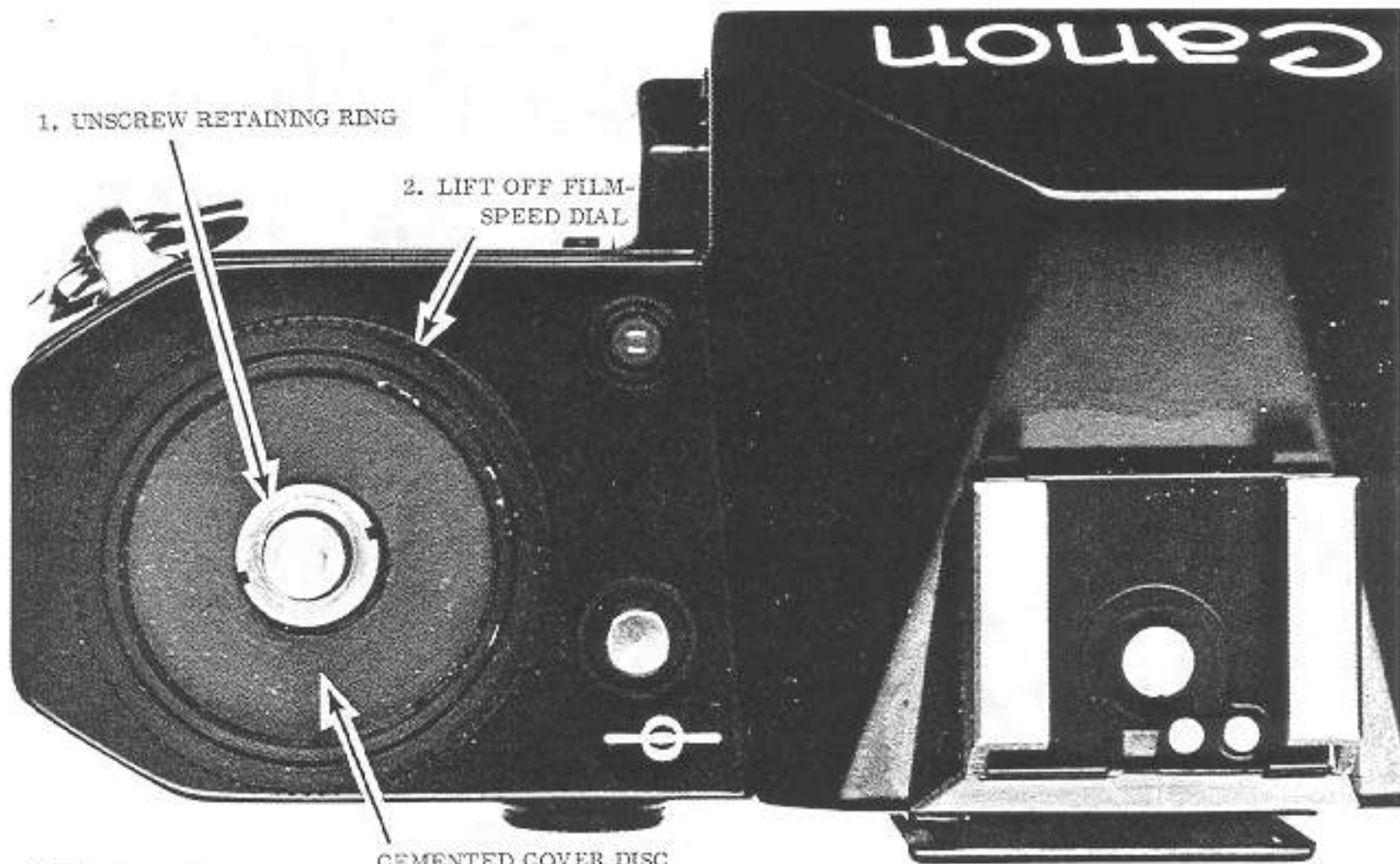

FILM-SPEED DIAL WITH CEMENTED  
COVER DISC REMOVED

FORK ON FILM-SPEED DIAL STRADDLES TAB ON FILM-SPEED COUPLER

SCREWS FOR MINOR ADJUSTMENTS ONCE TOP COVER IS INSTALLED

TAB ON FILM-SPEED COUPLER FACES  
FRONT OF CAMERA AT ASA100

FILM-SPEED COUPLER

PLANETARY GEARS OF FILM-SPEED GEAR UNIT

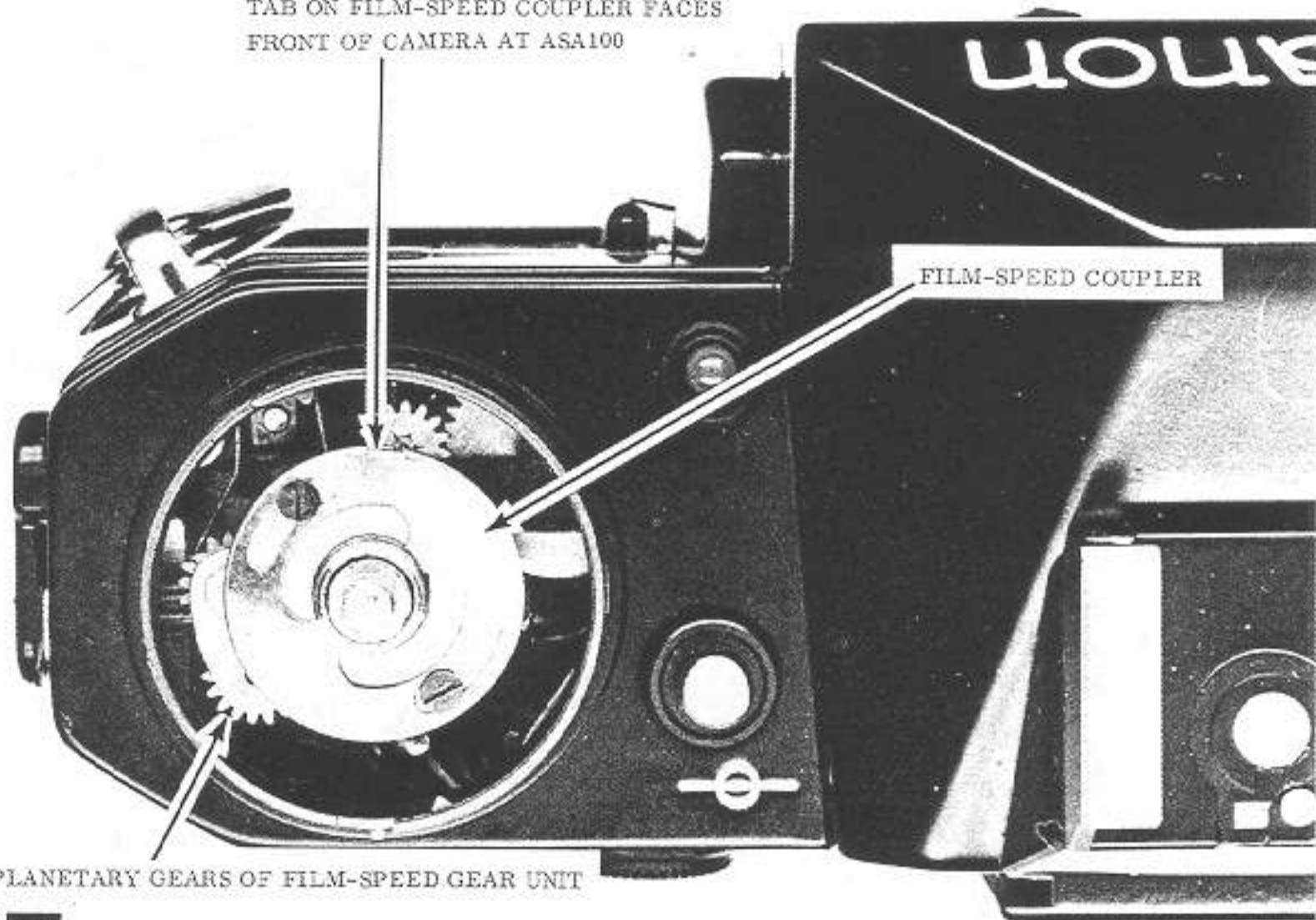

SPECIAL TOOL MAY BE SCREWED ONTO  
RETAINING-RING THREADS TO HOLD  
PARTS IN ASA100 POSITION



UNSCREW RETAINING SCREW AND LIFT OFF CATS-NORMAL SELECTOR

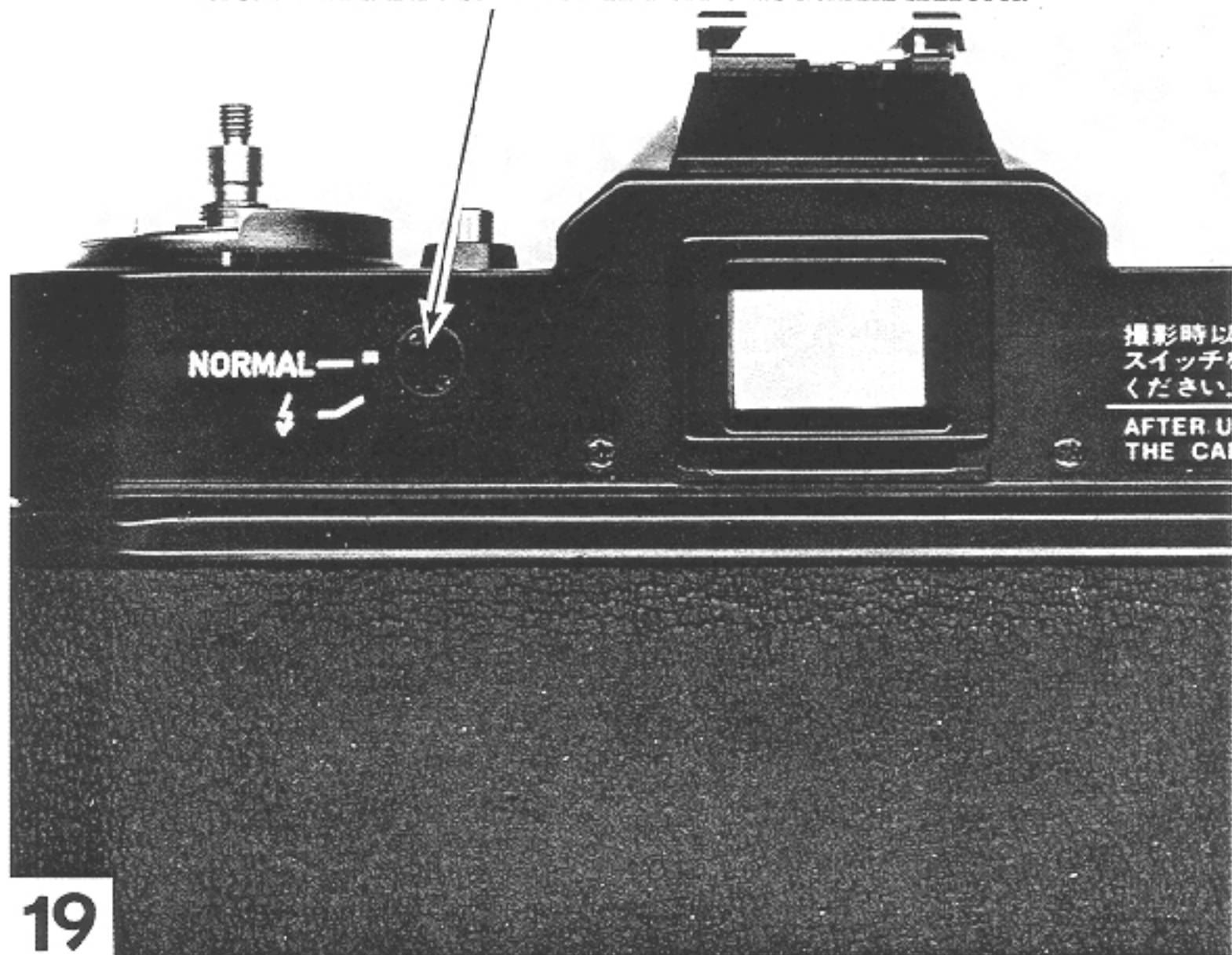

UNSCREW WIND-LEVER RETAINING RING

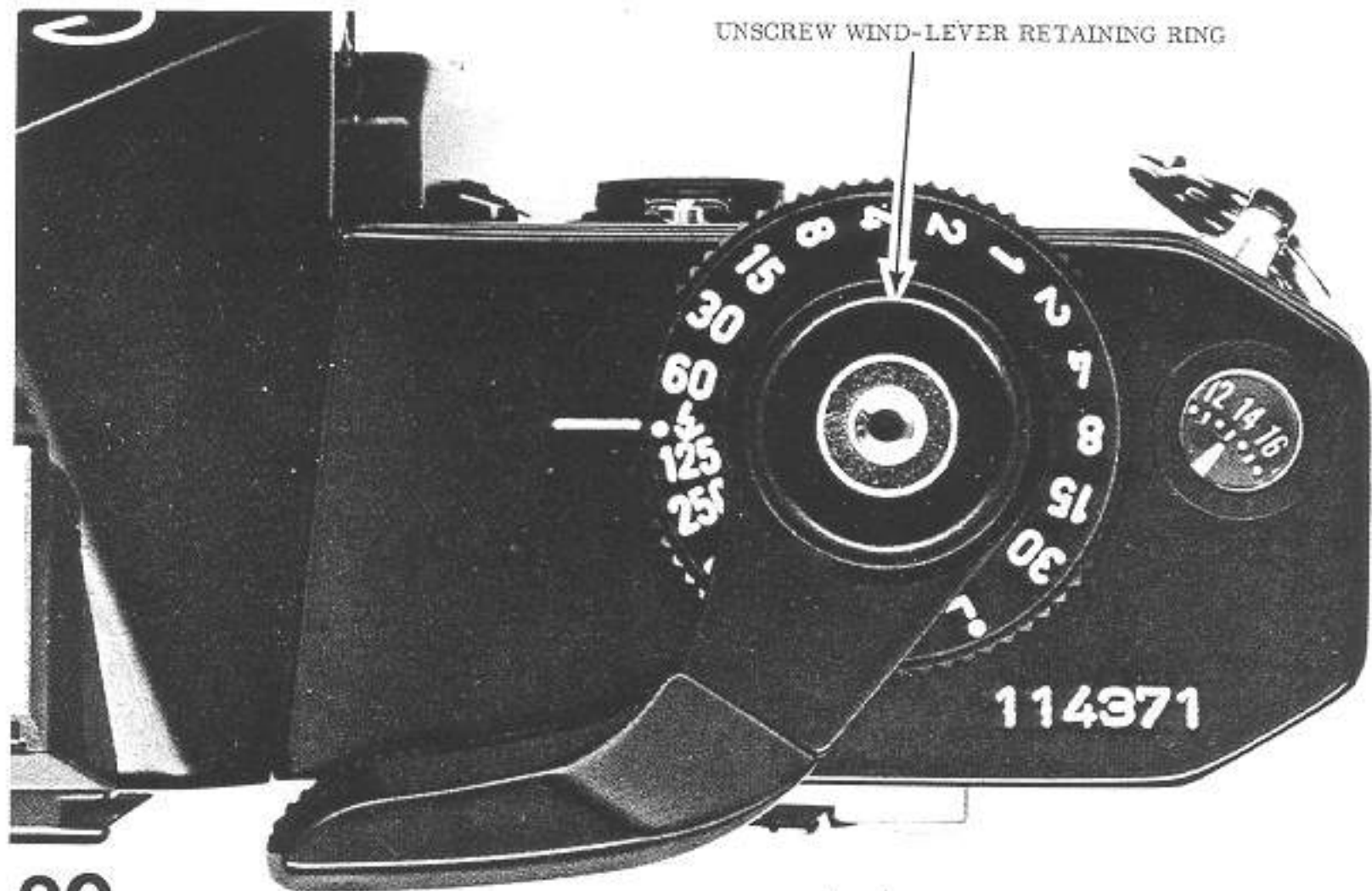

20

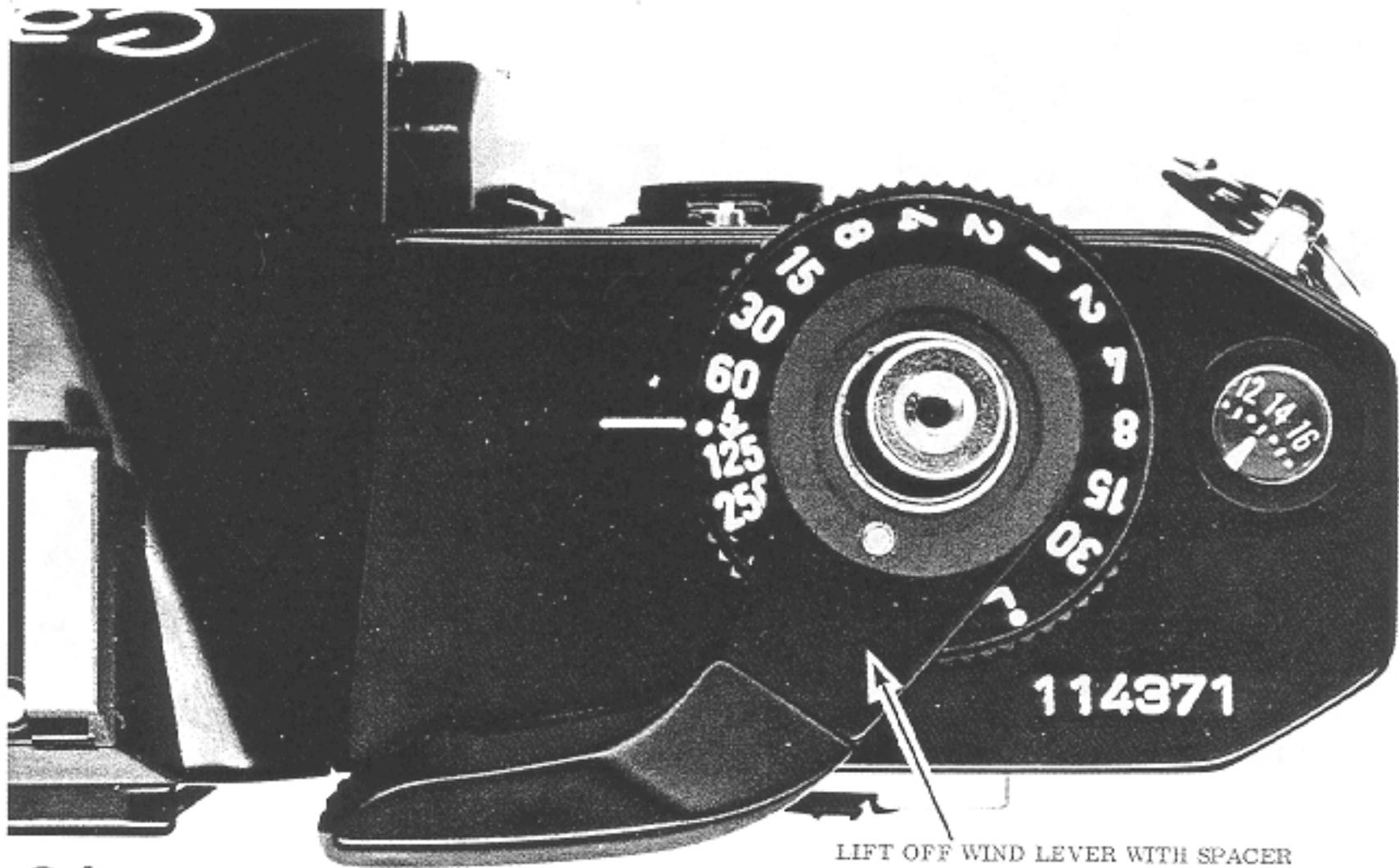

LIFT OFF WIND LEVER WITH SPACER

21

LIFT OUT WIND-LEVER COUPLING RING

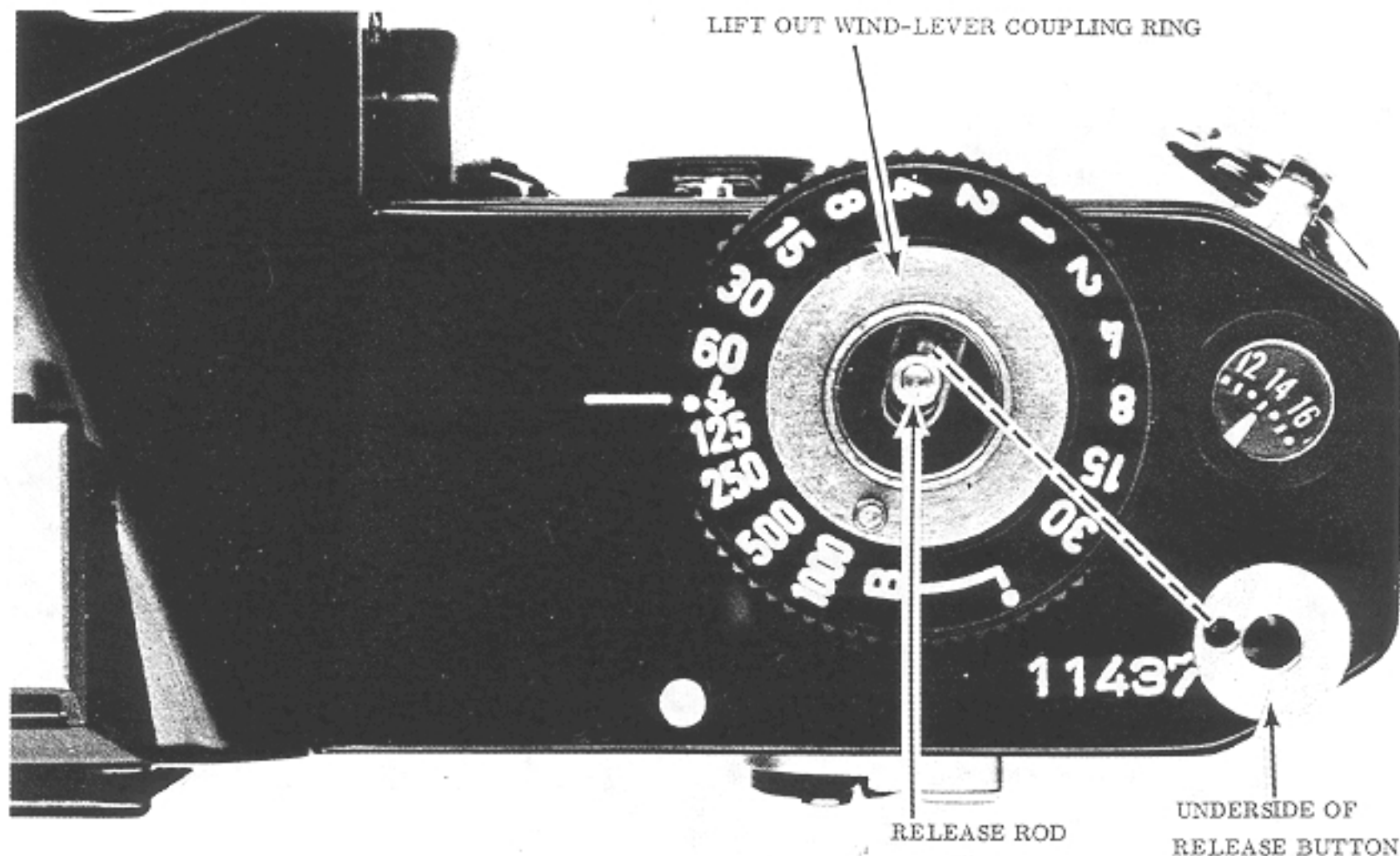

RELEASE ROD

UNDERSIDE OF  
RELEASE BUTTON

22

NOTE: IT'S NOT NECESSARY TO REMOVE THE  
RELEASE BUTTON; IF YOU DO, NOTE THE HOLE  
IN THE RELEASE BUTTON THAT FITS OVER THE  
FIN ON THE RELEASE ROD

TABS OF WIND-LEVER COUPLING RING PASS INTO SLOTS IN  
WIND-SHAFT COUPLER

WIND-SHAFT COUPLER

UNDERSIDE OF WIND-LEVER COUPLING RING

23

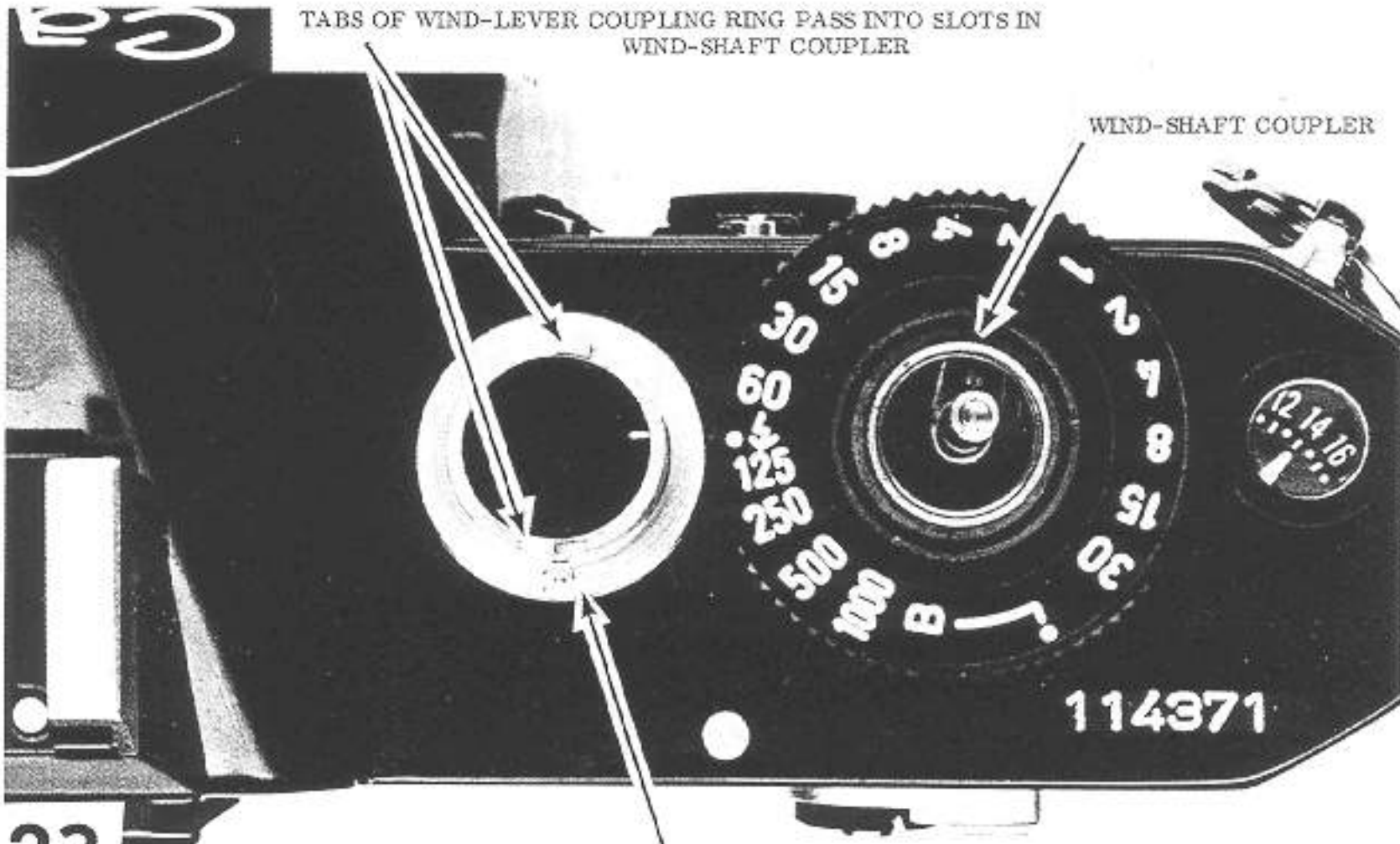

SET SHUTTER-SPEED DIAL TO "BULB" FOR REFERENCE

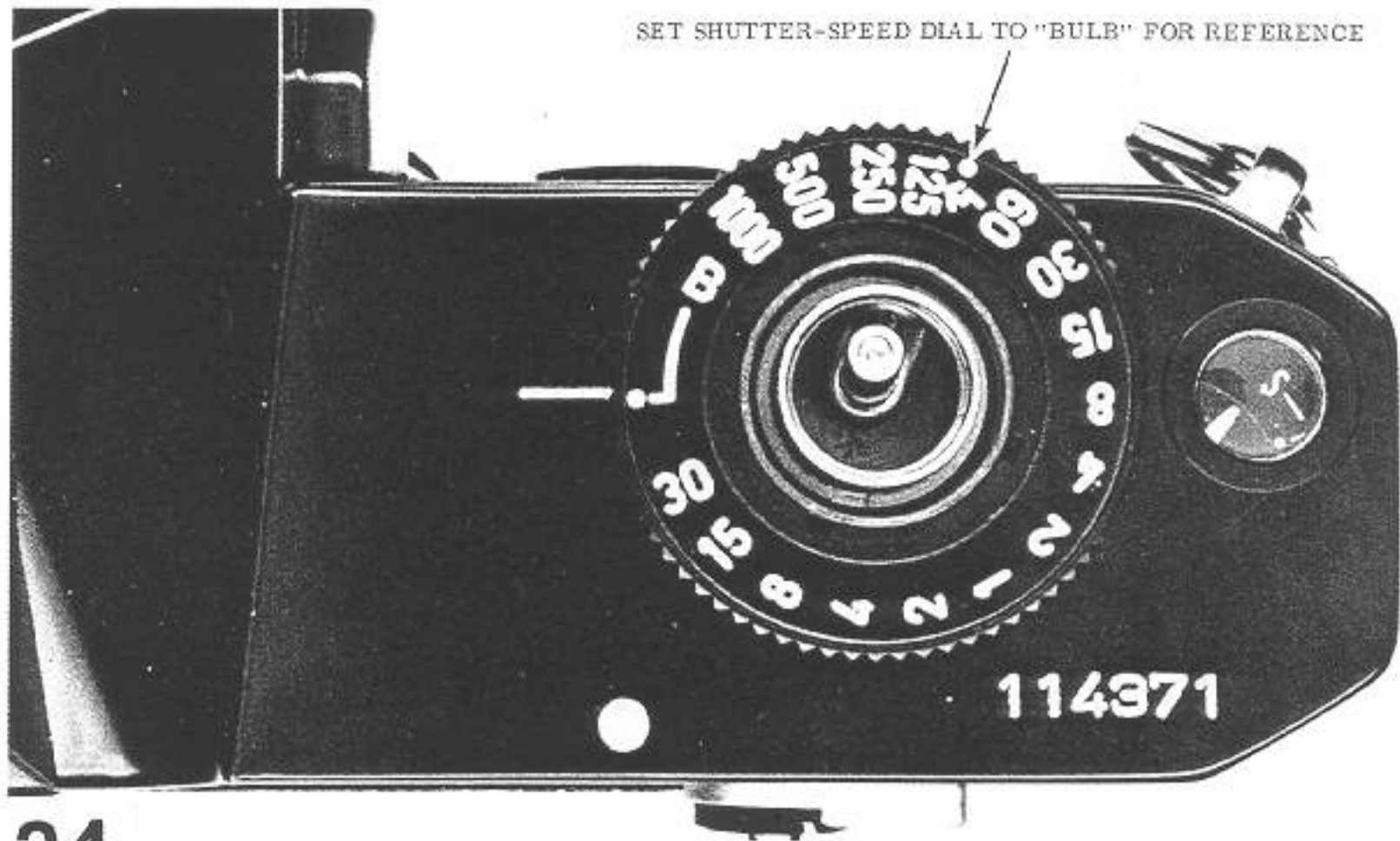

24

1. REMOVE SIX TOP-COVER RETAINING SCREWS --  
TWO AT ENDS OF TOP COVER, TWO AT SIDES  
OF PENTAPRISM, AND TWO SHOWN HERE

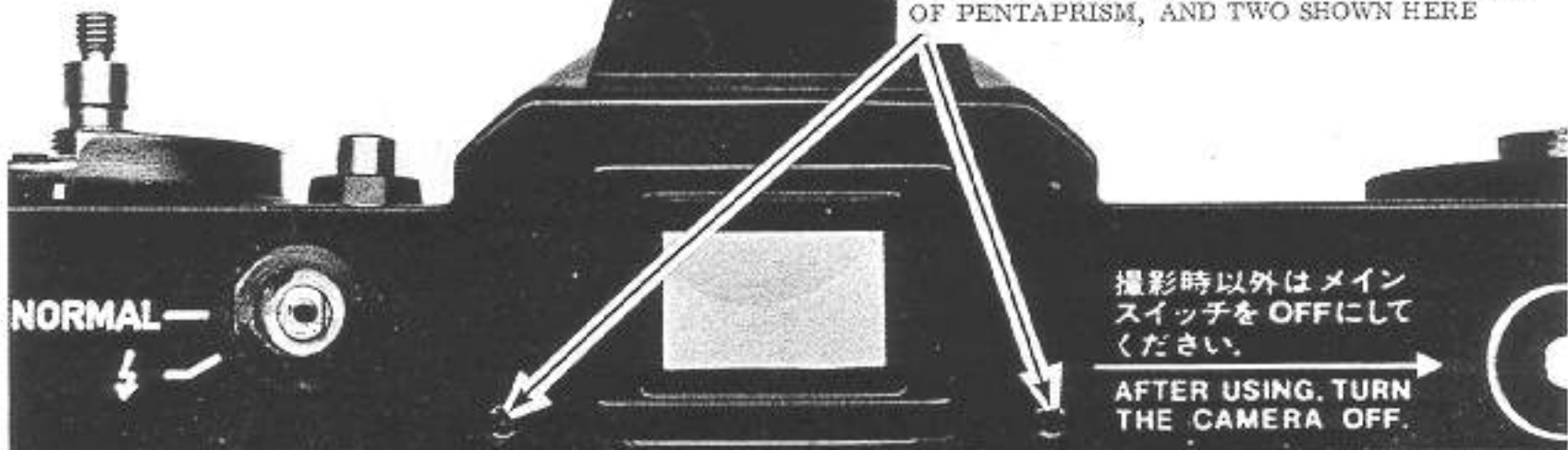

撮影時以外はメイン  
スイッチをOFFにして  
ください。

AFTER USING. TURN  
THE CAMERA OFF.

2. LIFT OFF TOP COVER

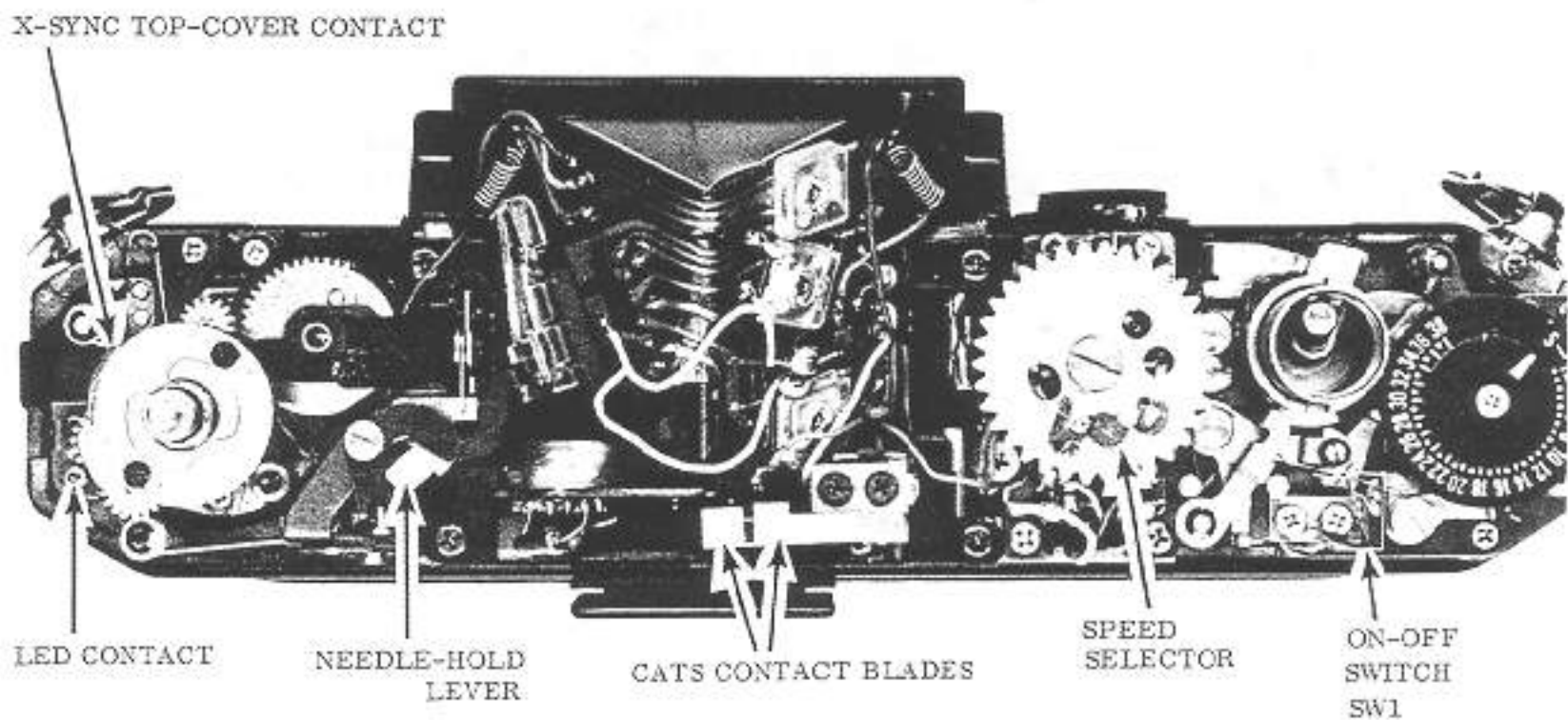
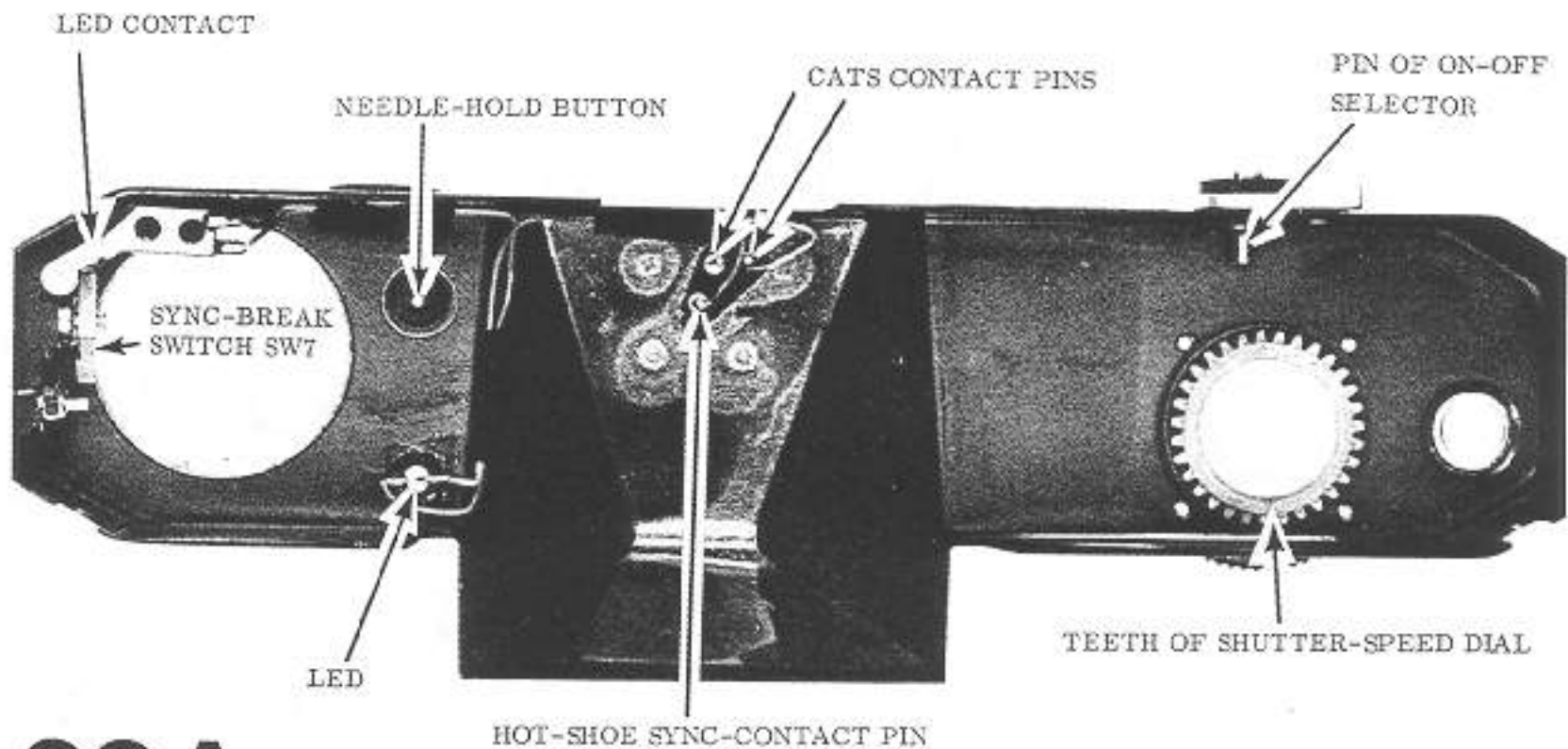



LED

THE LED SHOULD GLOW WITH 2 VOLTS  
APPLIED ACROSS THE TERMINALS

**27**

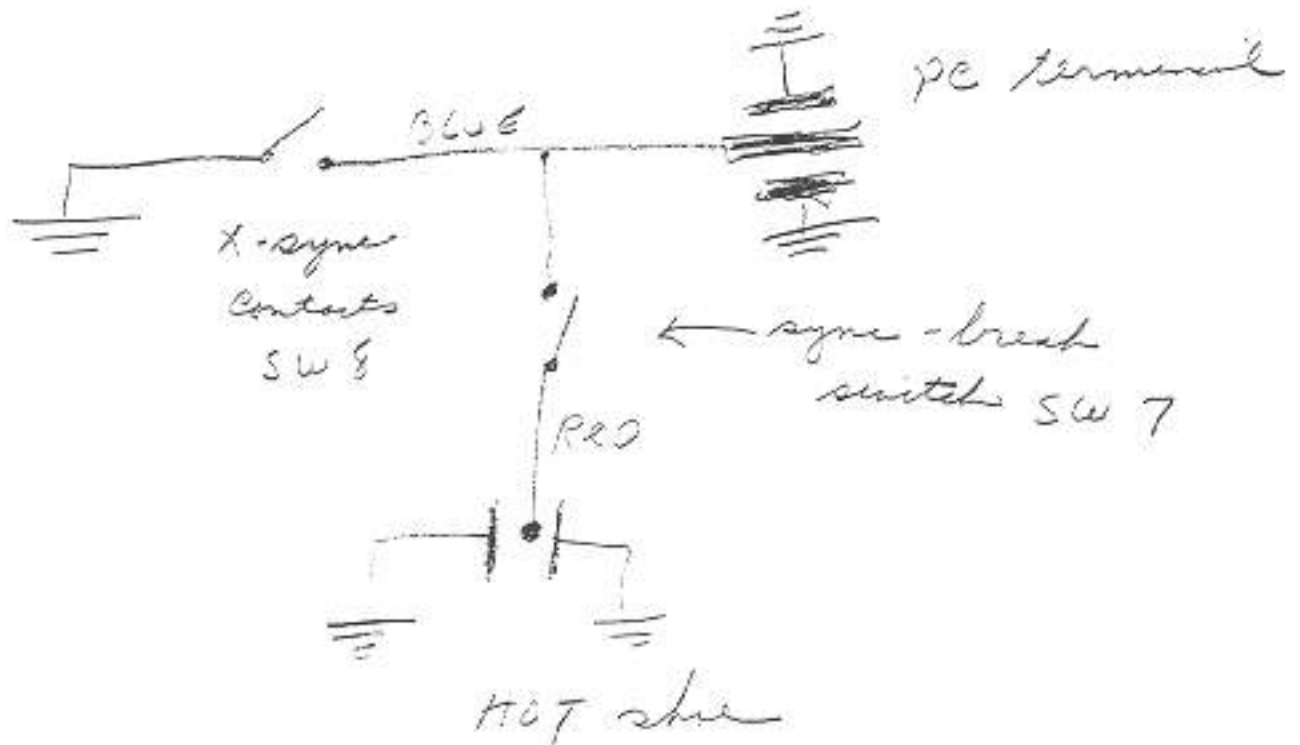

WHEN REPLACING THE TOP COVER, HOLD THE X-SYNC TOP-COVER CONTACT AWAY FROM THE SYNC-TERMINAL CONTACT

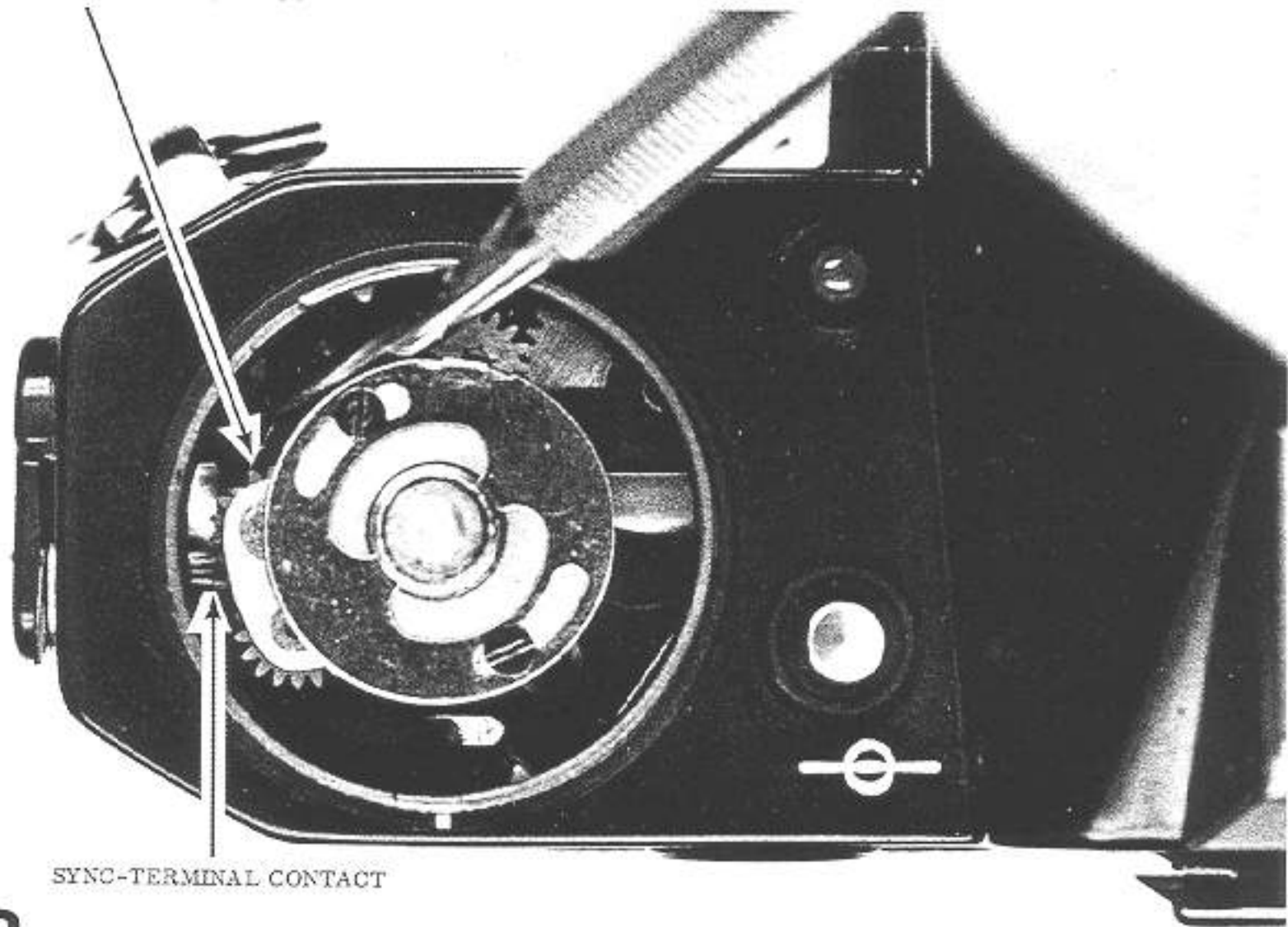

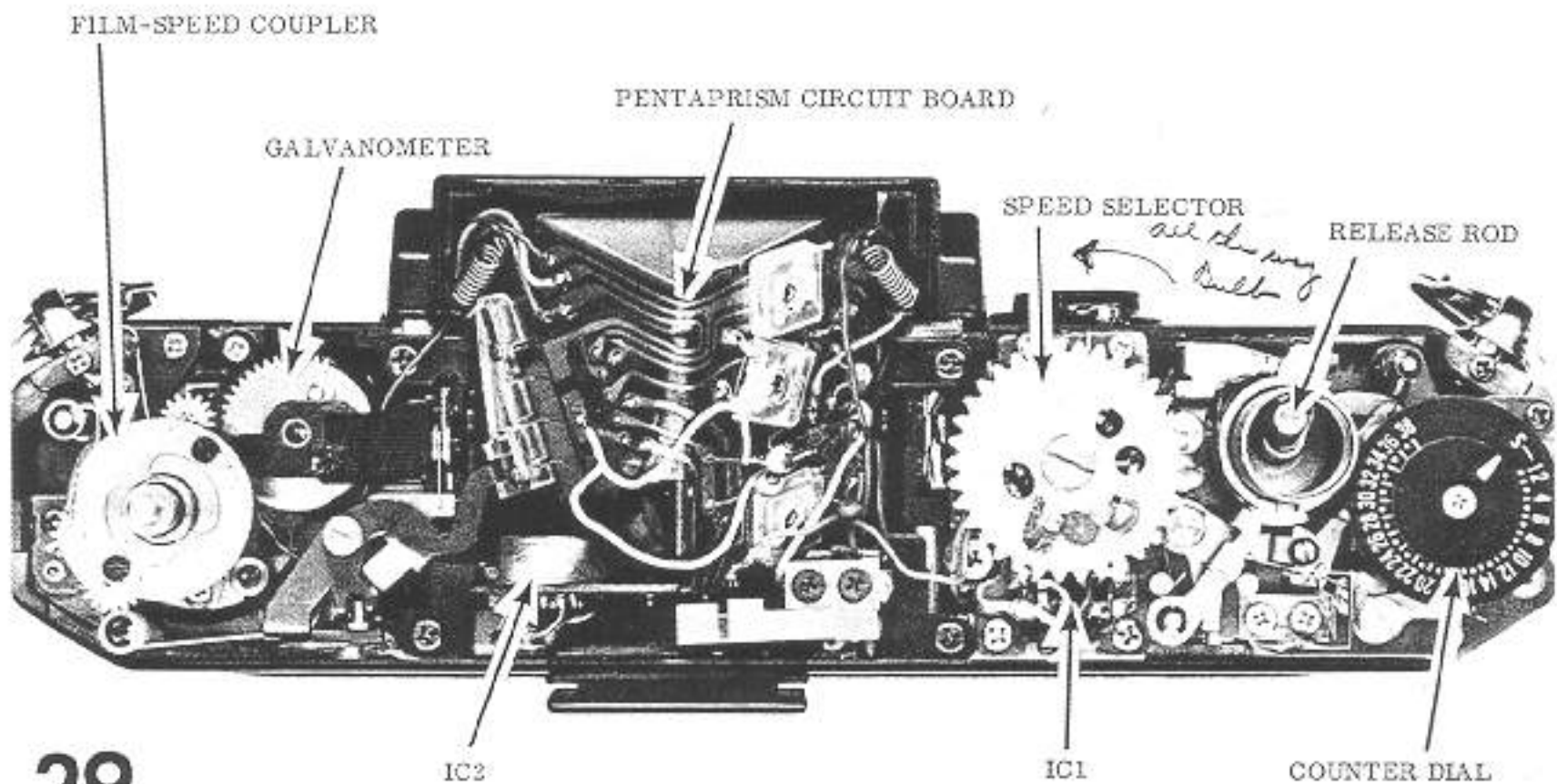

*IC1 - Electromagnet switch*

*IC2 - magnet amplifier*

*when faulty - meter drops suddenly down*

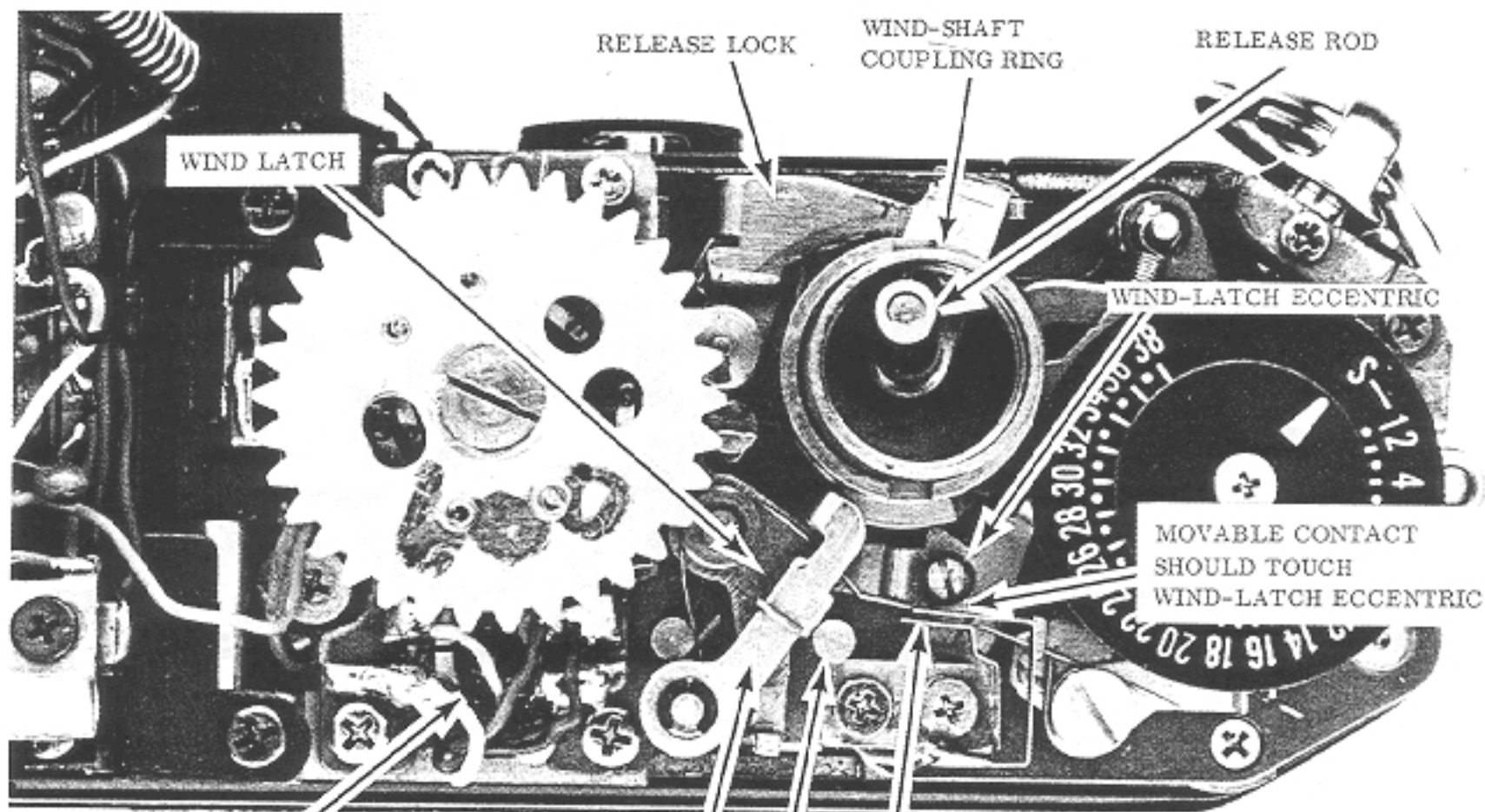

WIND LATCH

RELEASE LOCK

WIND-SHAFT  
COUPLING RING

RELEASE ROD

WIND-LATCH ECCENTRIC

MOVABLE CONTACT  
SHOULD TOUCH  
WIND-LATCH ECCENTRIC

ICI

SPACE BETWEEN SWITCH  
BLADES SHOULD BE 0.4 - 0.6 mm

SPRING  
LEVER

ON-OFF  
SWITCH SW1

SPRING-LEVER ECCENTRIC

30

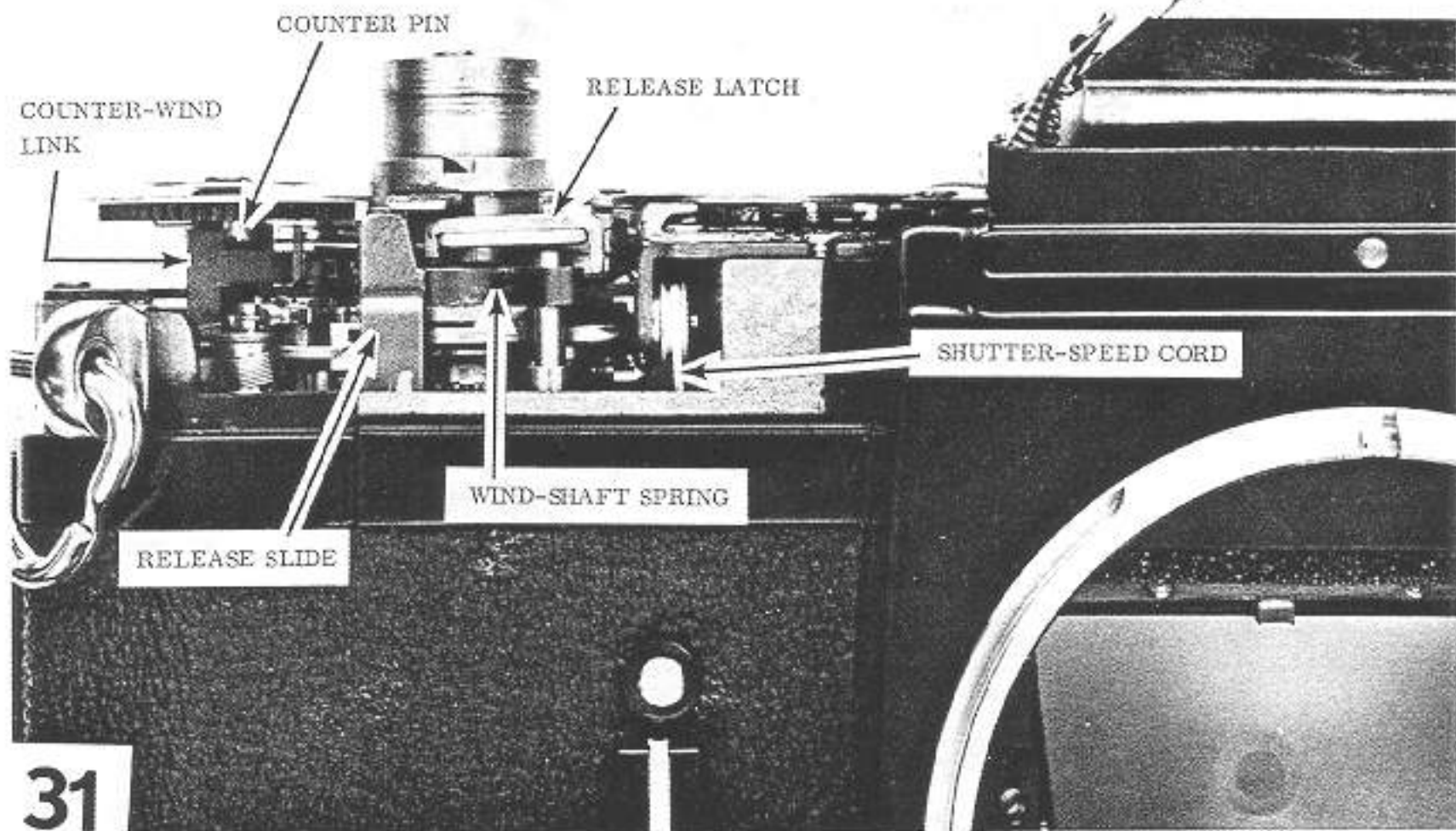

REPLACE WIND-LEVER PARTS TO OPERATE SHUTTER

PUSH WIND-LATCH TAB TO THE LEFT TO  
DISENGAGE WIND-SHAFT COUPLING RING AND  
COCK SHUTTER -- TO RELEASE SHUTTER,  
PUSH DOWN RELEASE SLIDE

DOUBLE-EXPOSURE LEVER

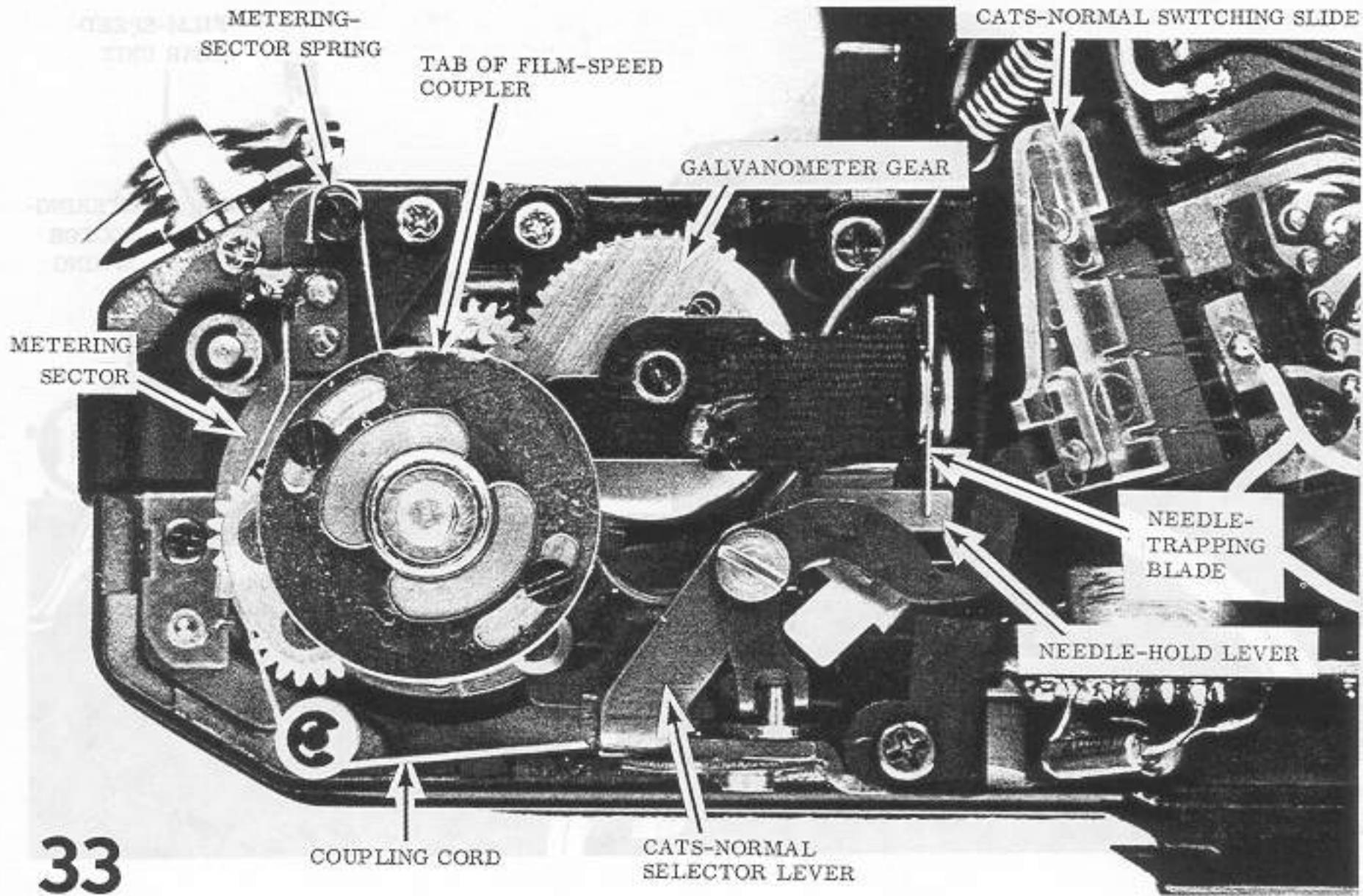

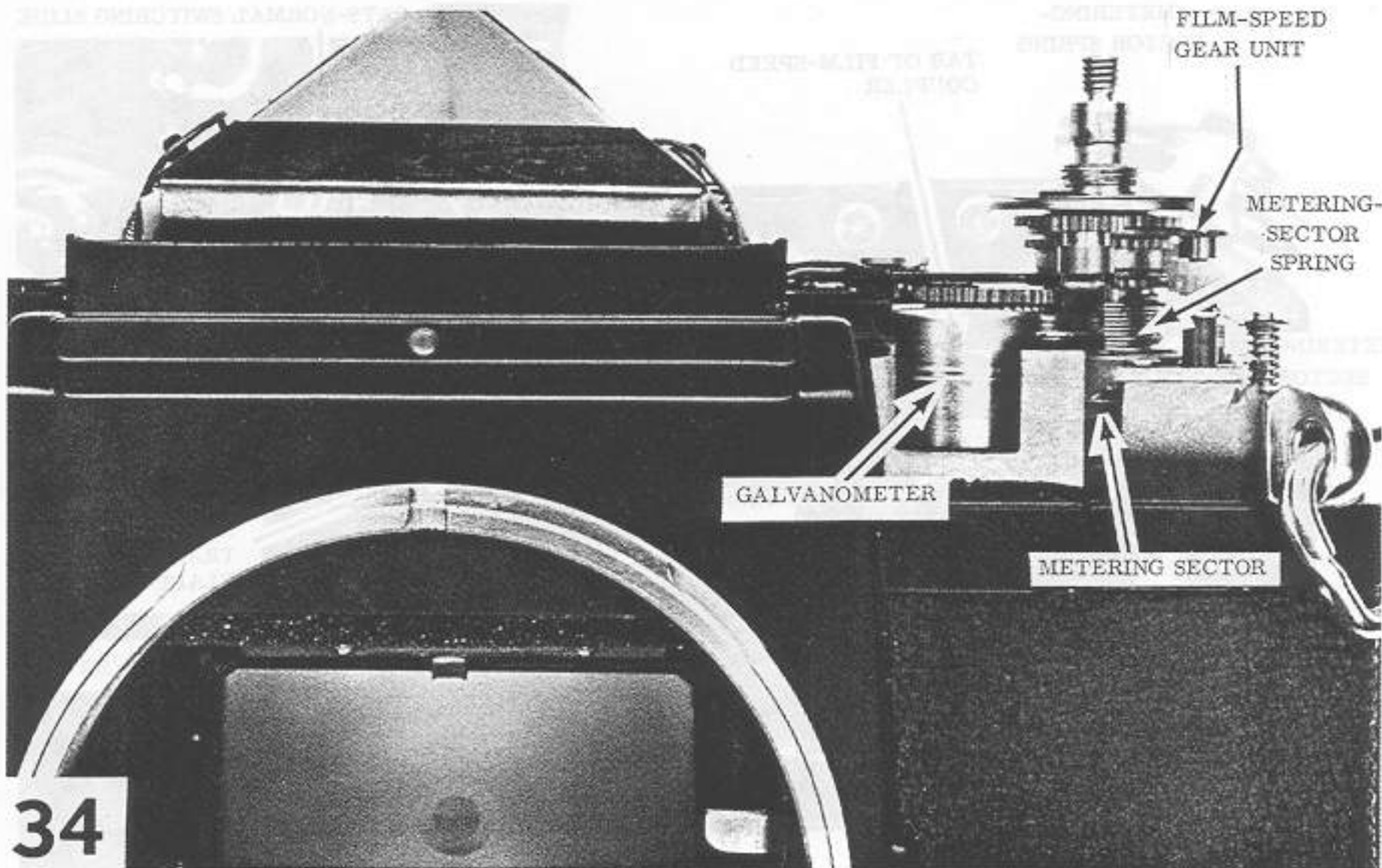

34

CATS-NORMAL SWITCHES  
SW9, SW10, AND SW11

VR4 (METER RESPONSE ADJUSTMENT)  
VR2 (METER LINEARITY ADJUSTMENT)

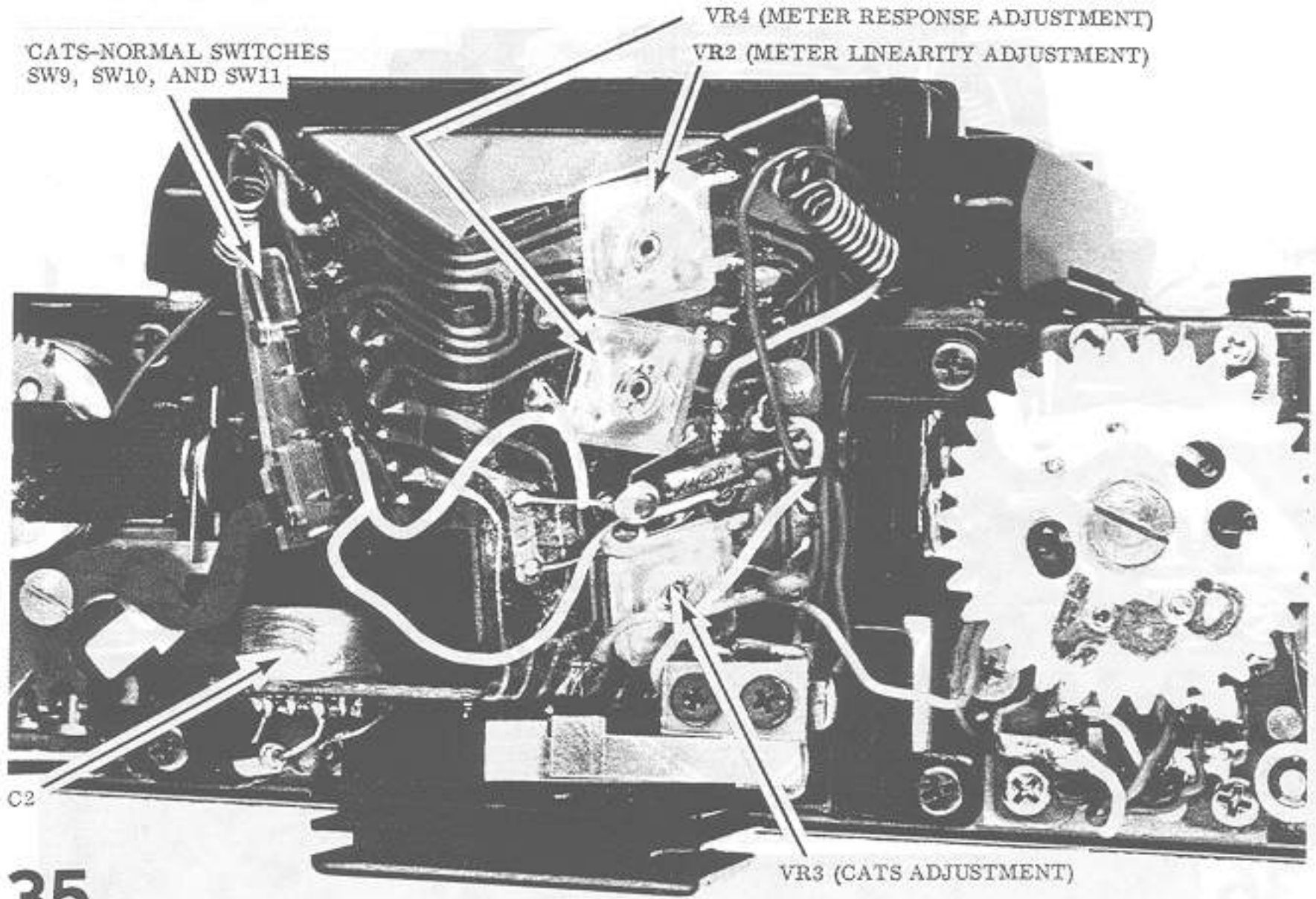

C2

VR3 (CATS ADJUSTMENT)

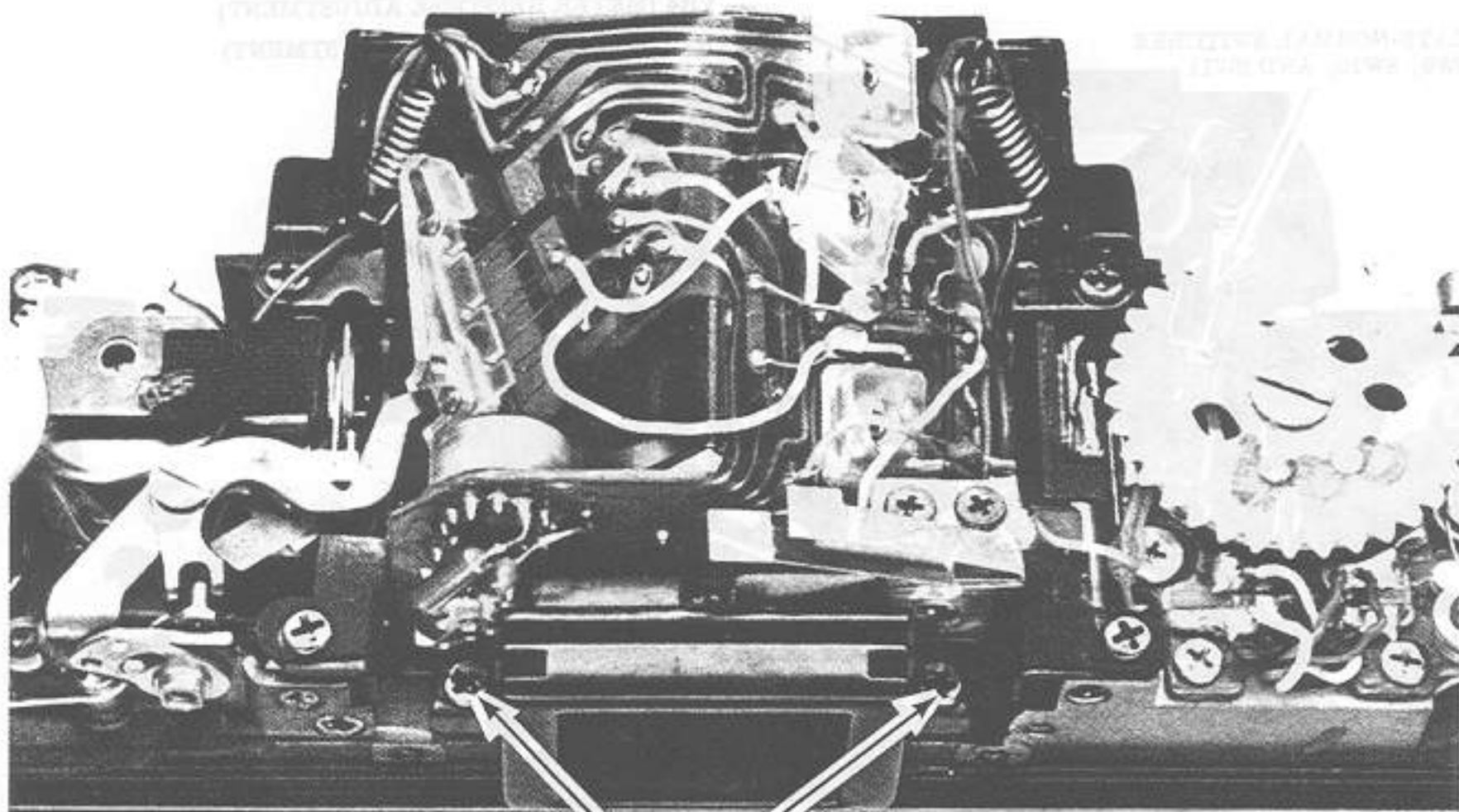

REMOVE TWO SCREWS AND LIFT OUT EYELENS

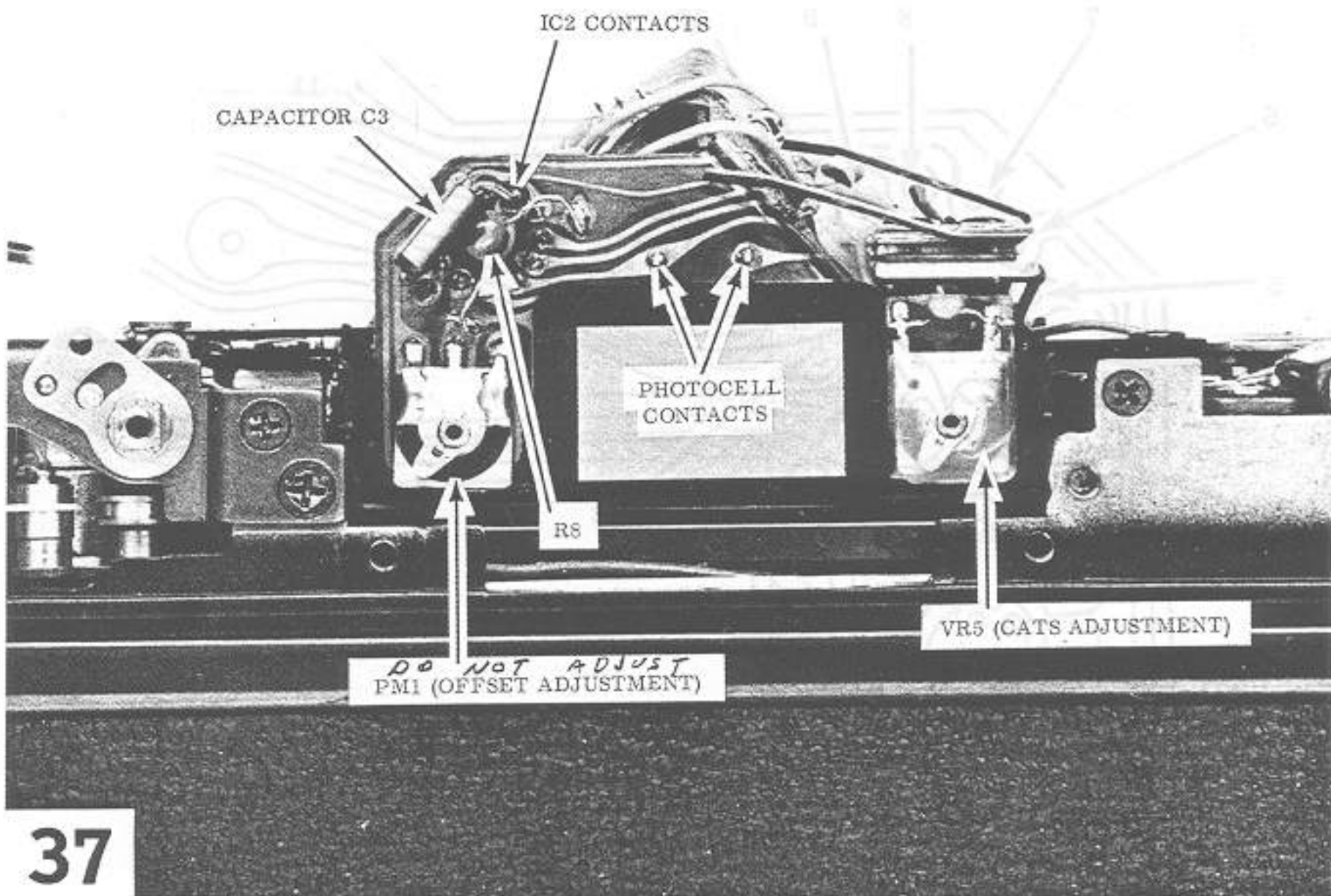

*Photo cells*



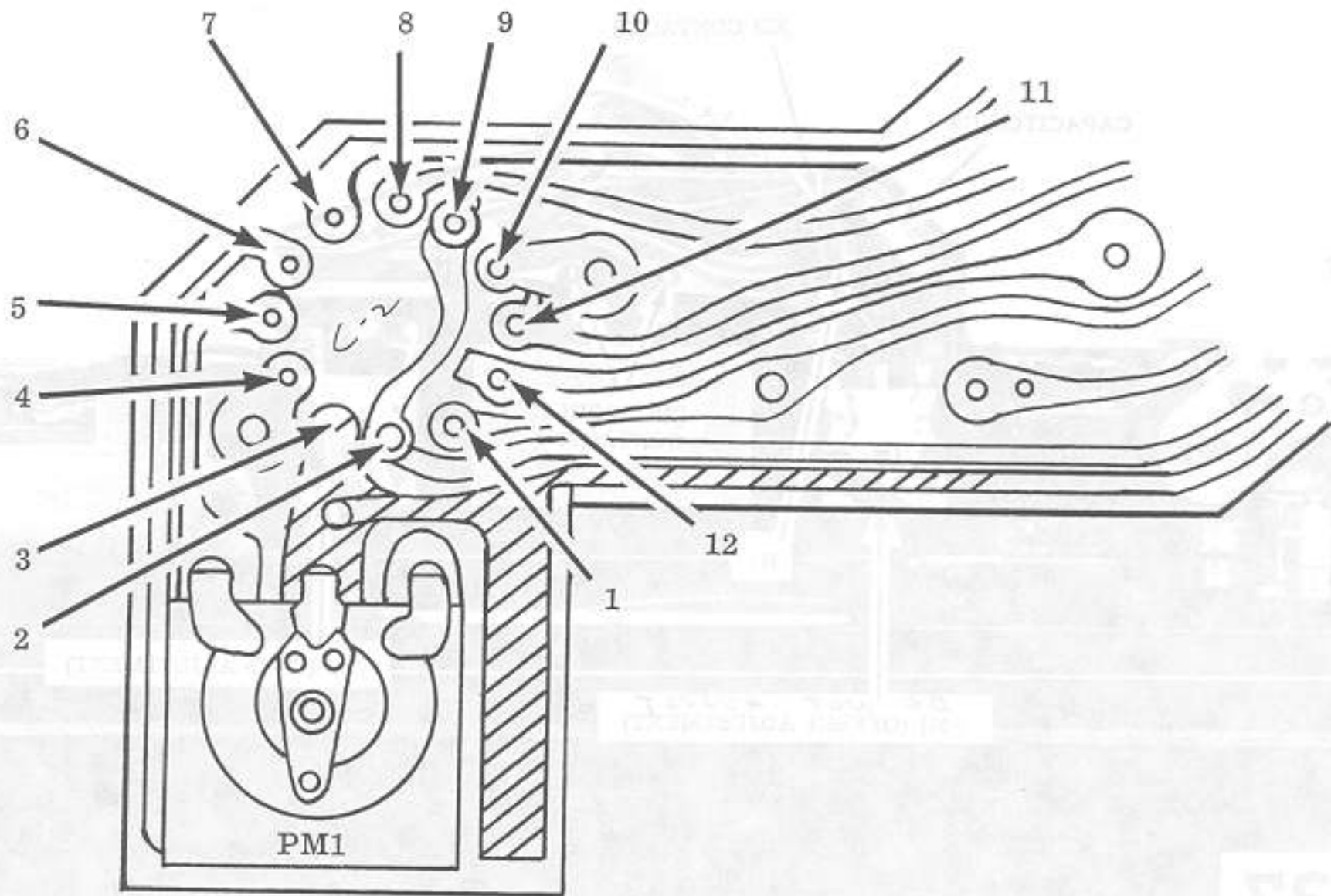

**38**

CATS-NORMAL SWITCHING SLIDE

CATS-NORMAL SELECTOR LEVER

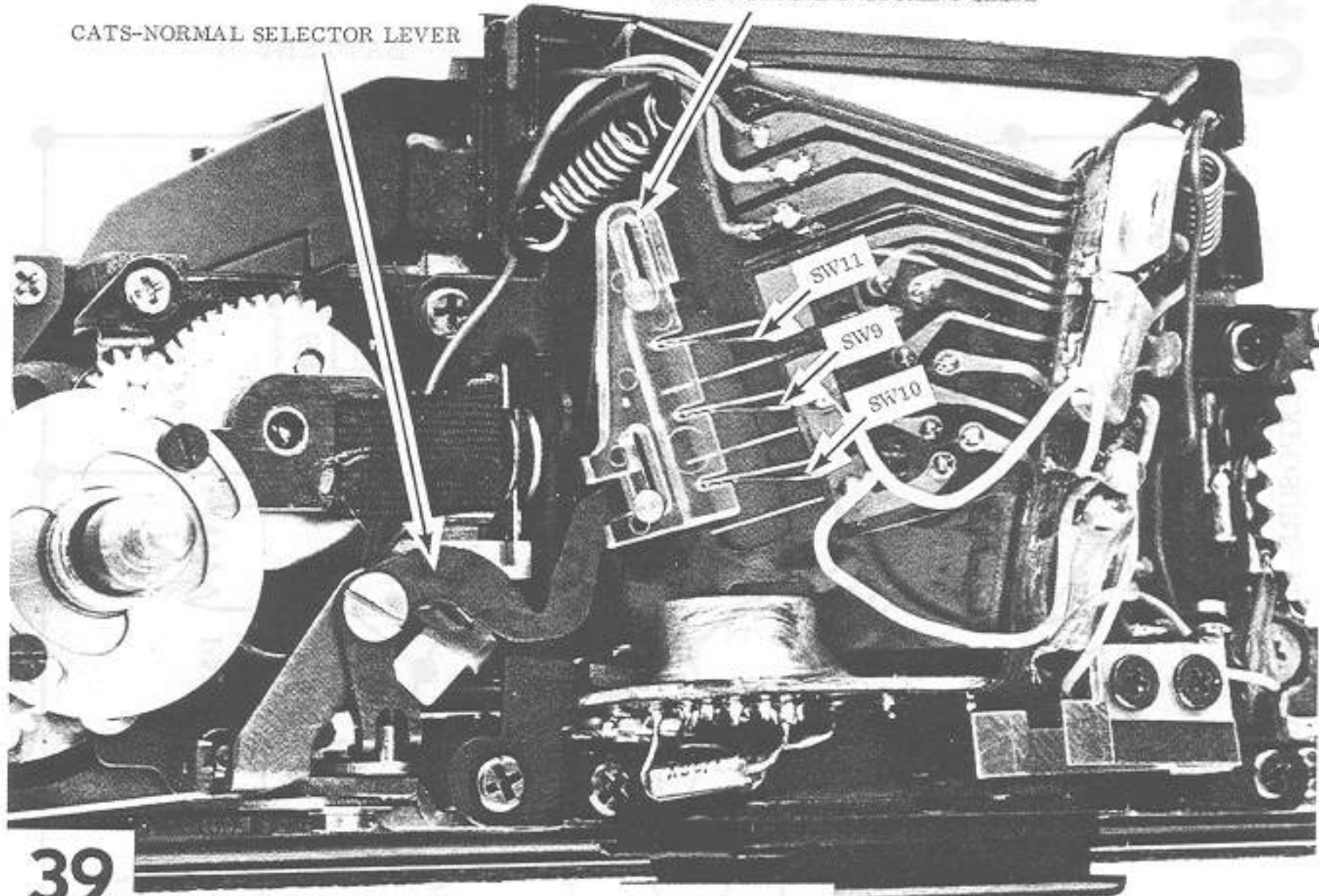

39

"NORMAL" POSITION

BATTERY #1

BATTERY #2

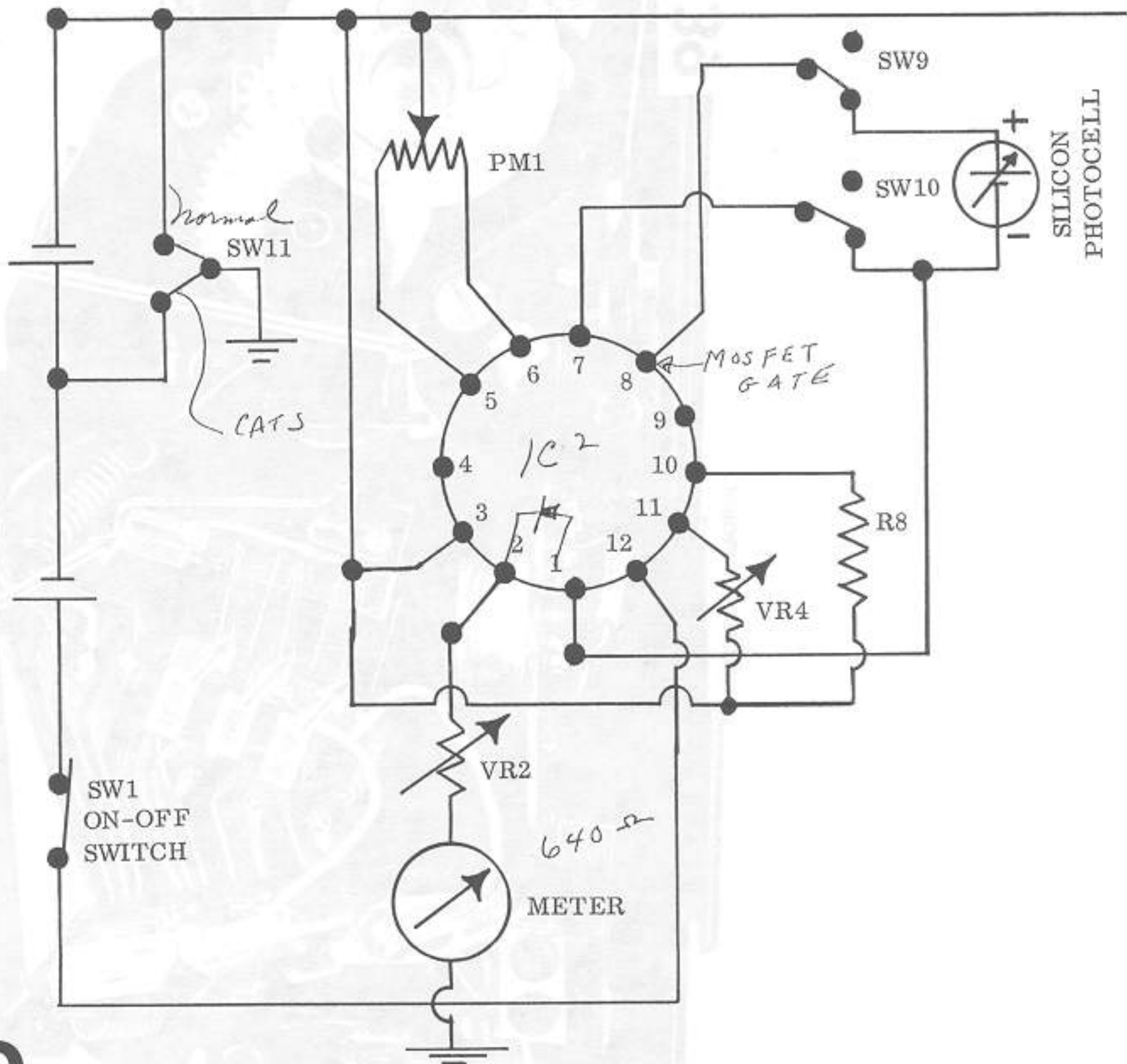

EXPOSURE-METER CIRCUIT

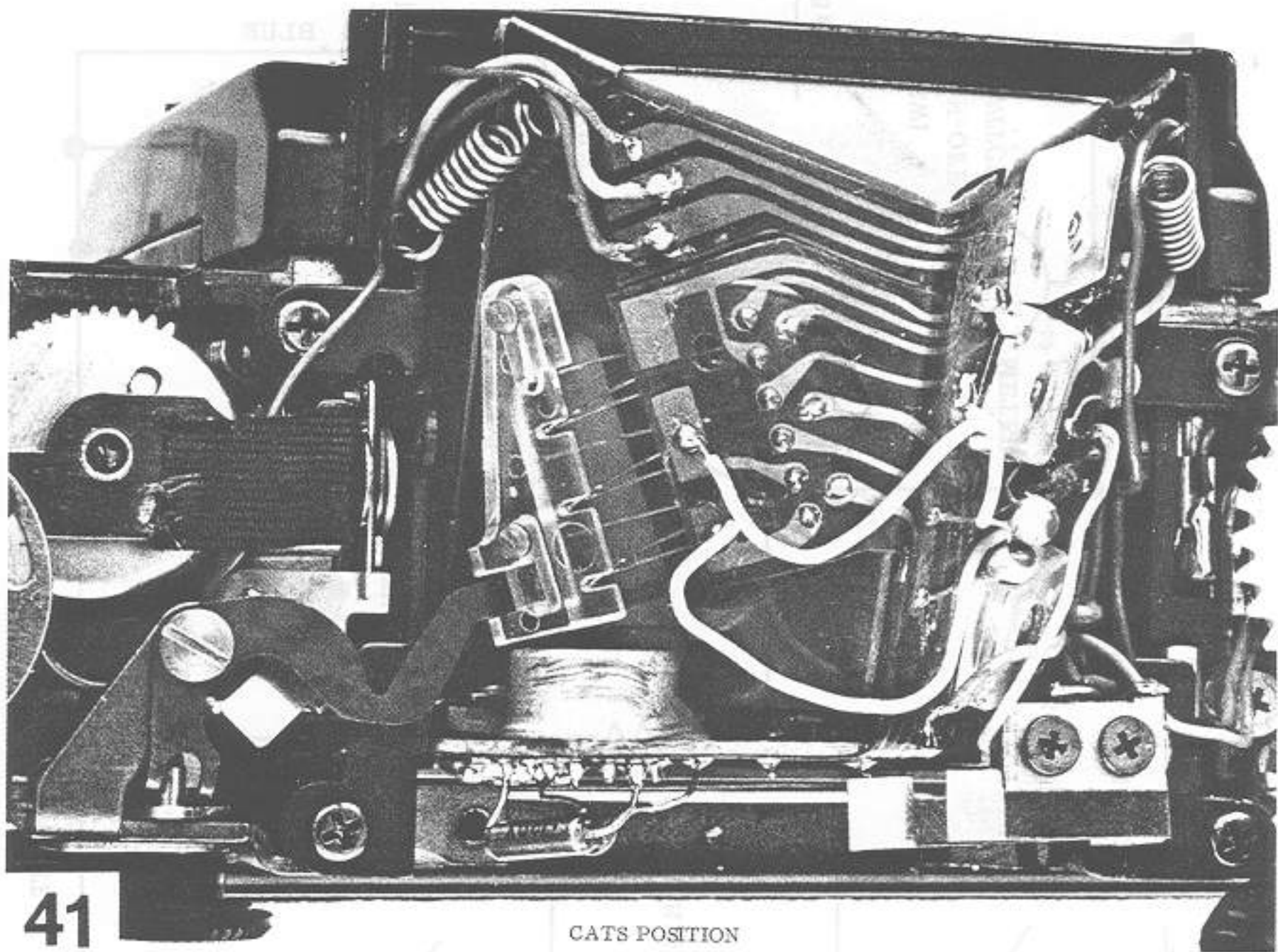

41

CATS POSITION

CATS CIRCUIT

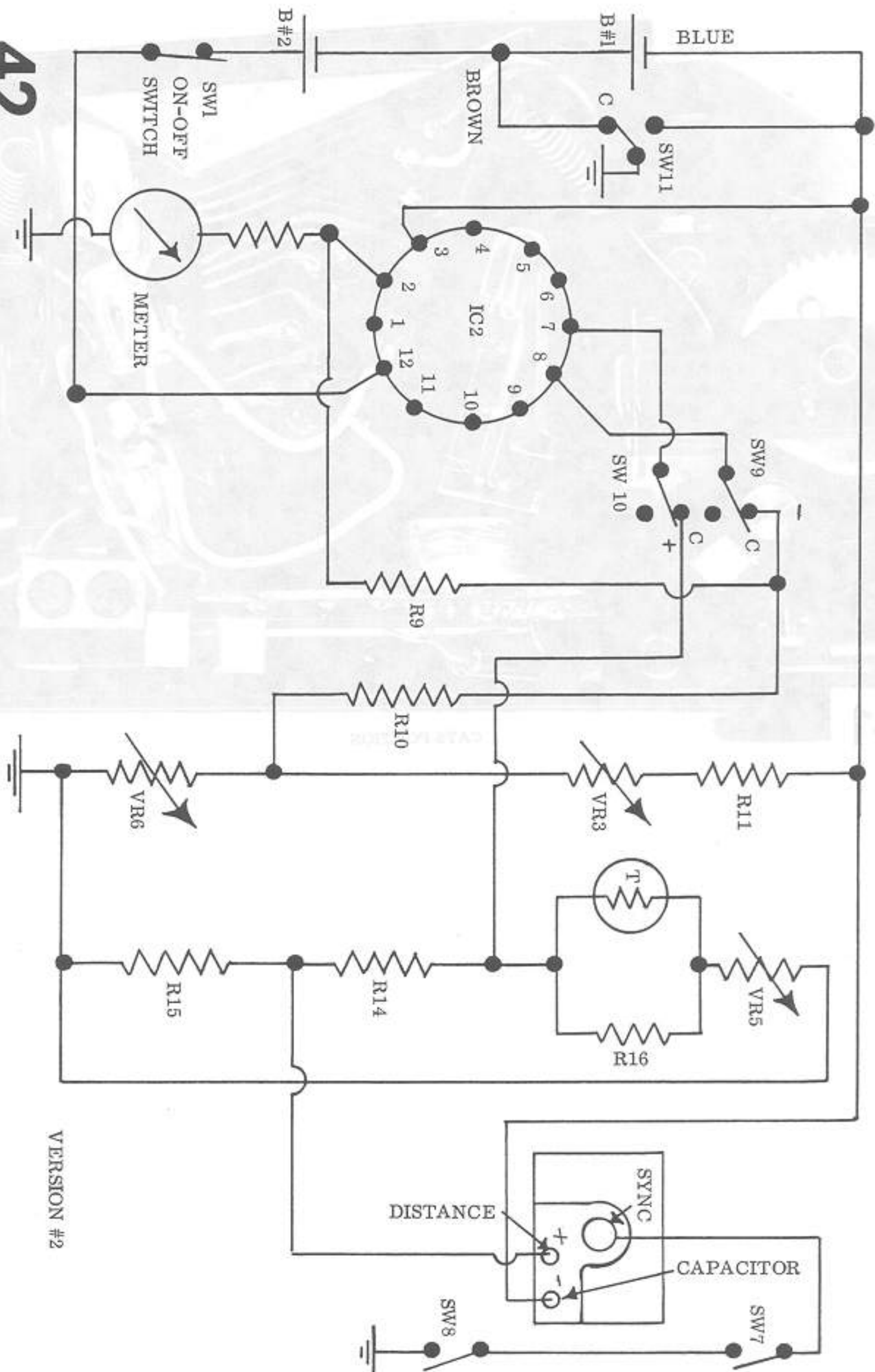

REMOVE SCREW AND LIFT OFF SPEED SELECTOR

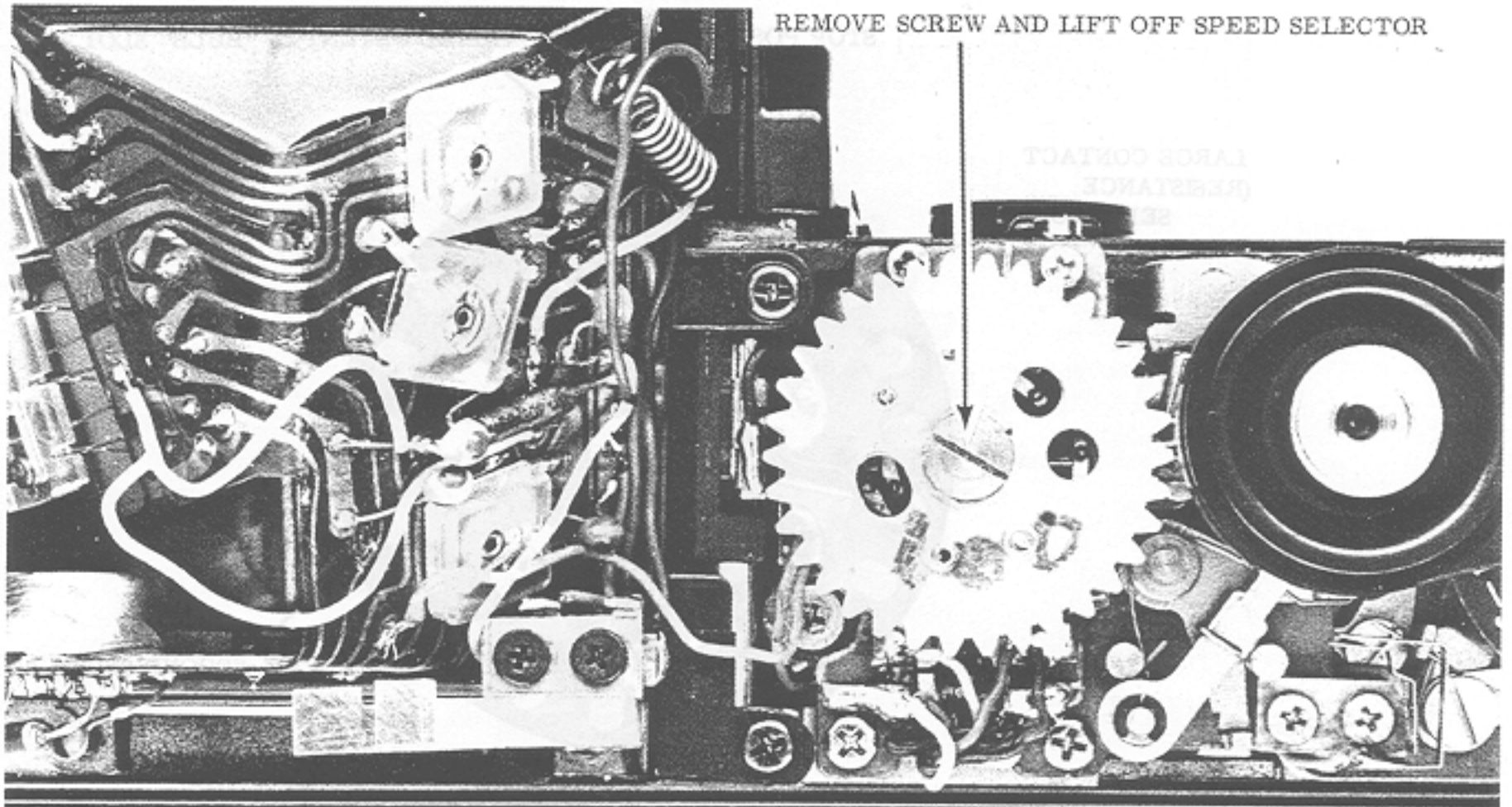

CAUTION: SPEED-SELECTOR BALL DETENT  
WILL BE LOOSE WHEN YOU LIFT OFF SPEED  
SELECTOR

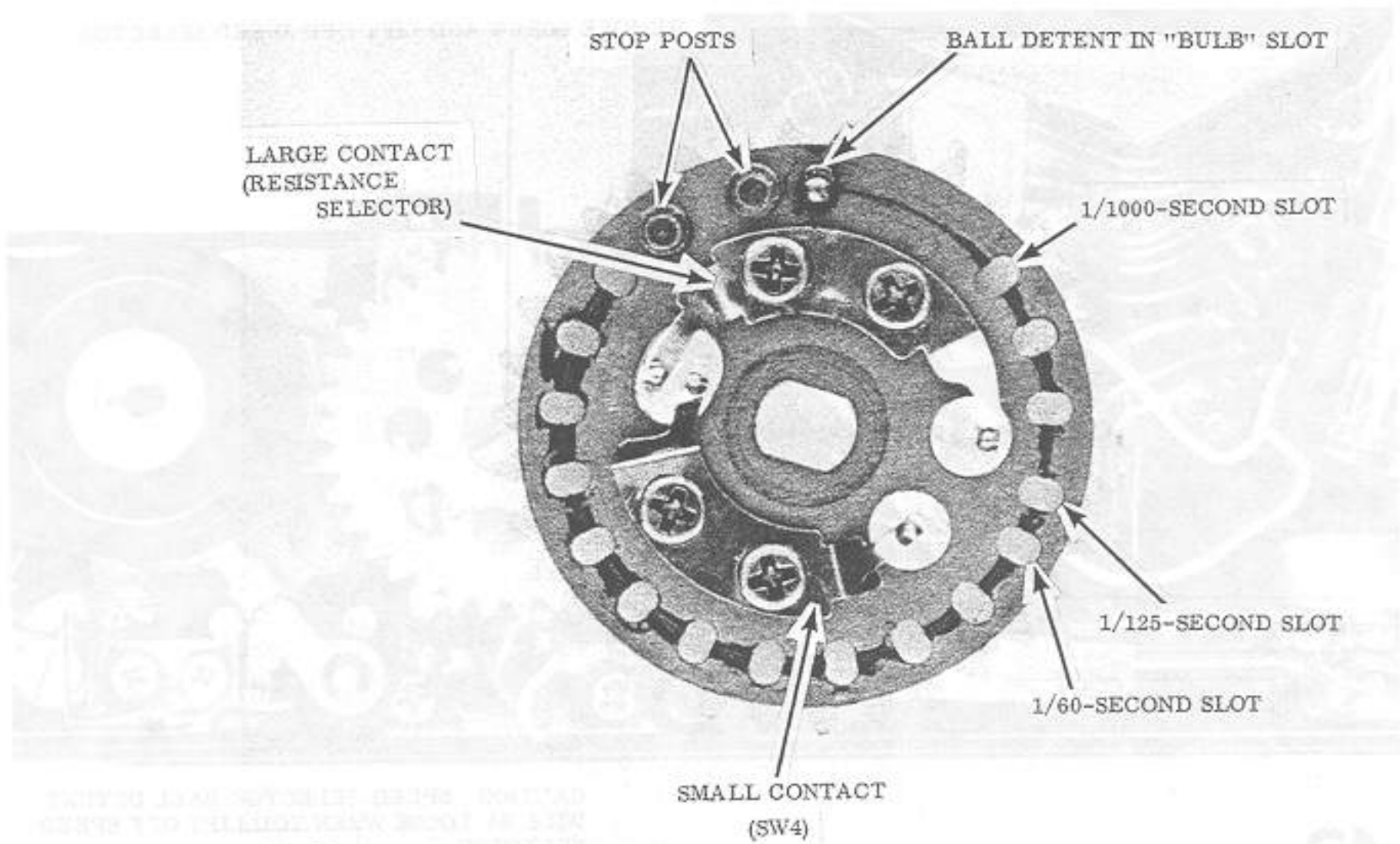

44

UNDERSIDE OF SPEED SELECTOR

SLOW-SPEED RESISTORS

LIFT COMPRESSION  
SPRING OUT OF  
STOP POST

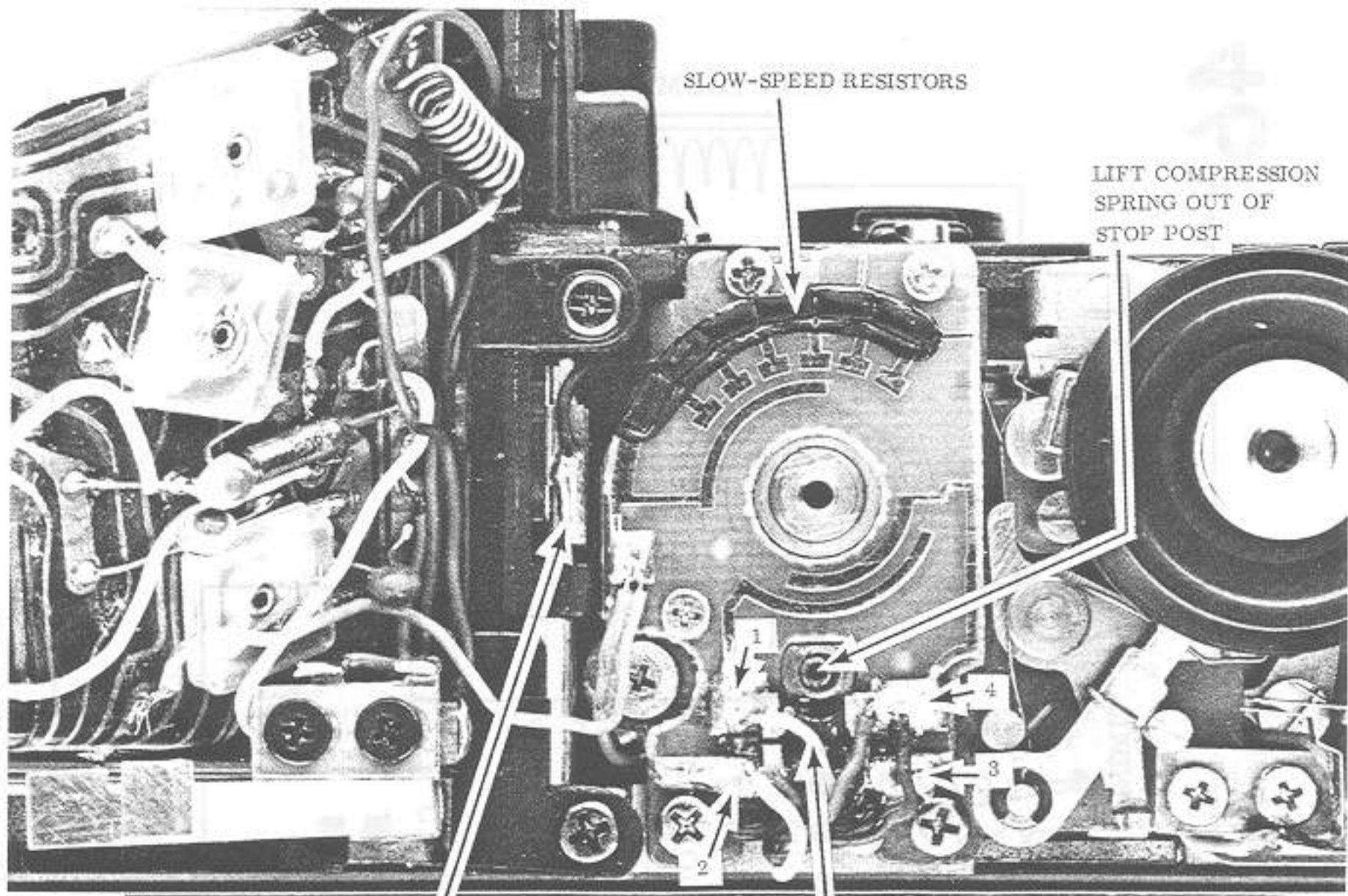

45

HOLDING SWITCH SW2

IC1



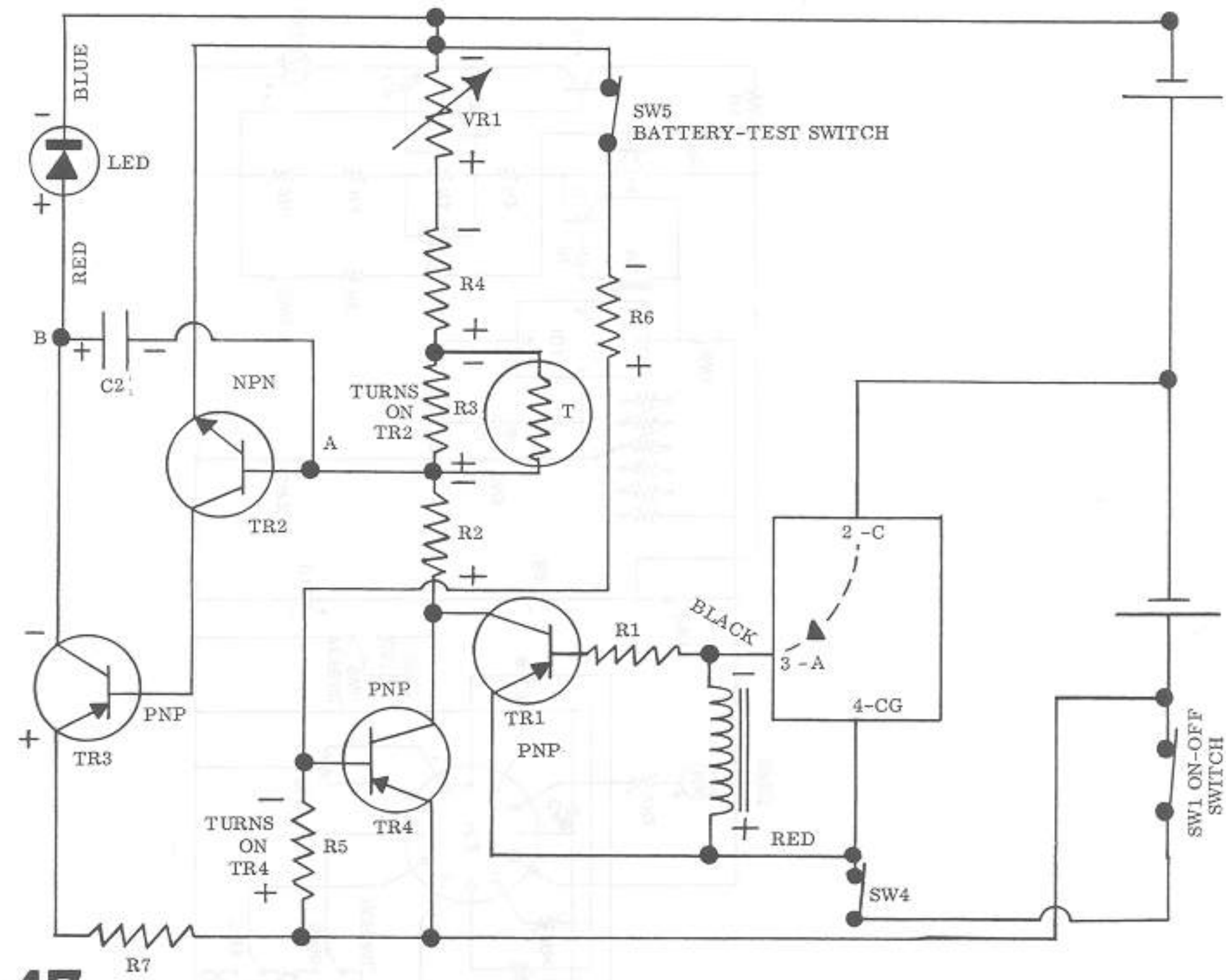

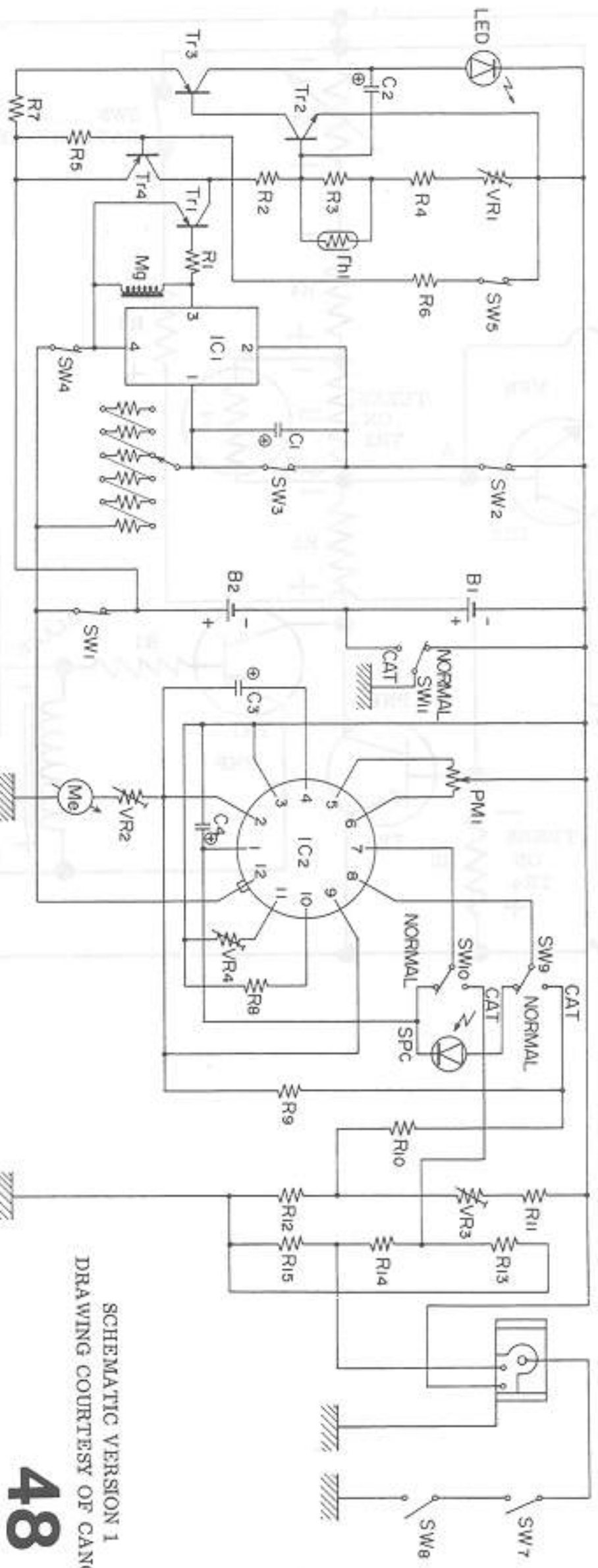

SCHEMATIC VERSION 1  
DRAWING COURTESY OF CANON

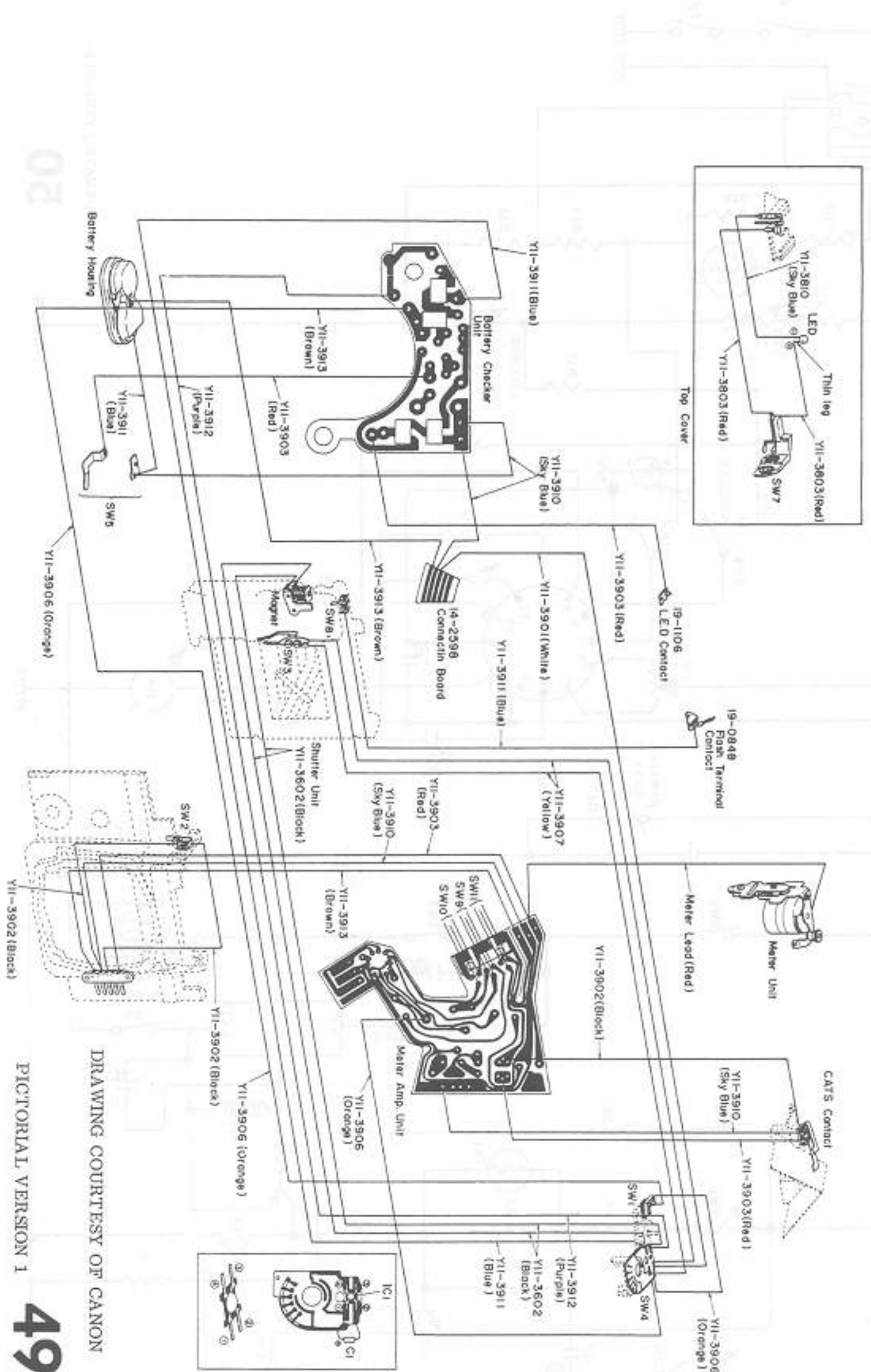

DRAWING COURTESY OF CANON  
 PICTORIAL VERSION 1 **49**

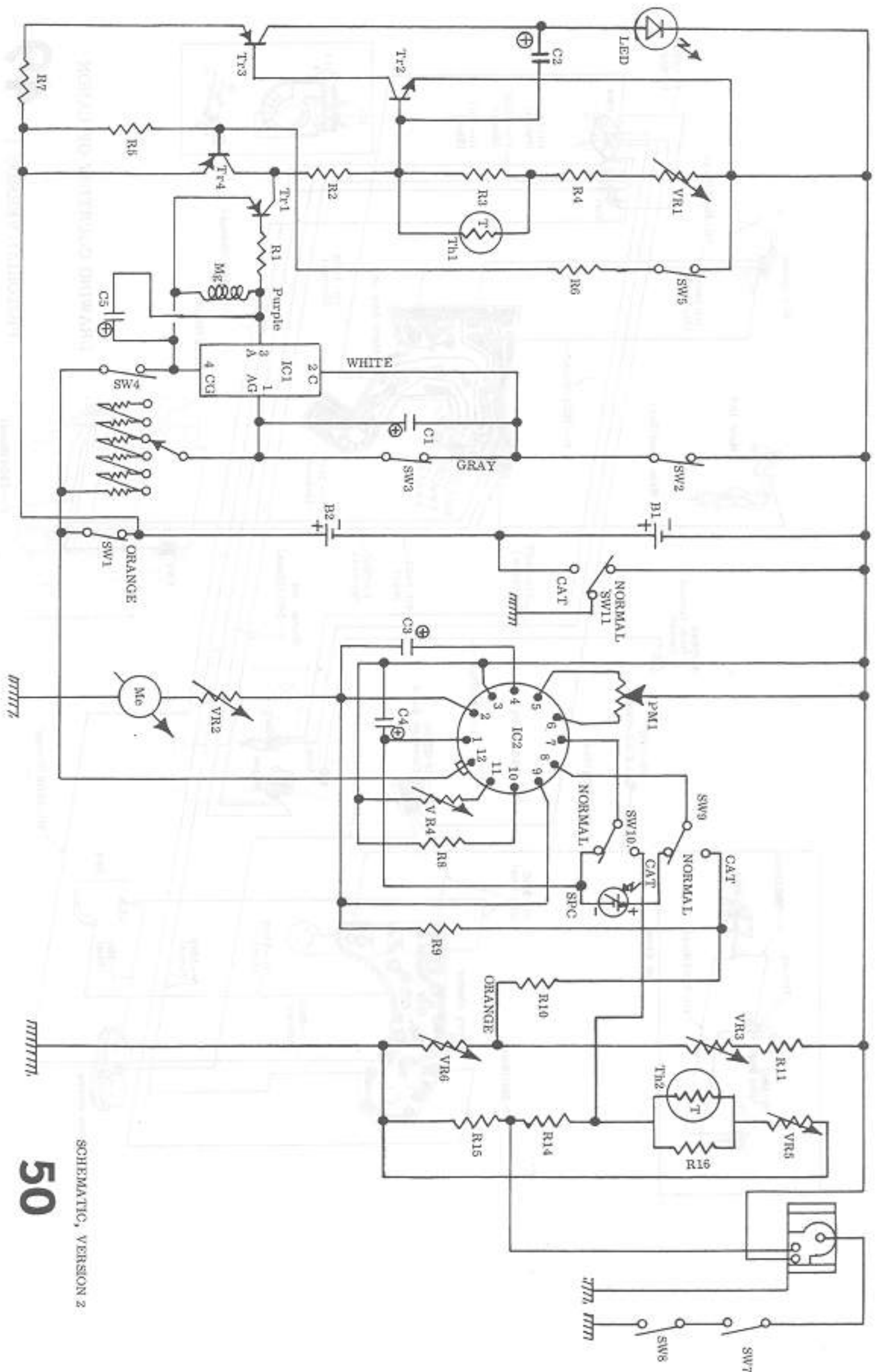

SCHEMATIC, VERSION 2

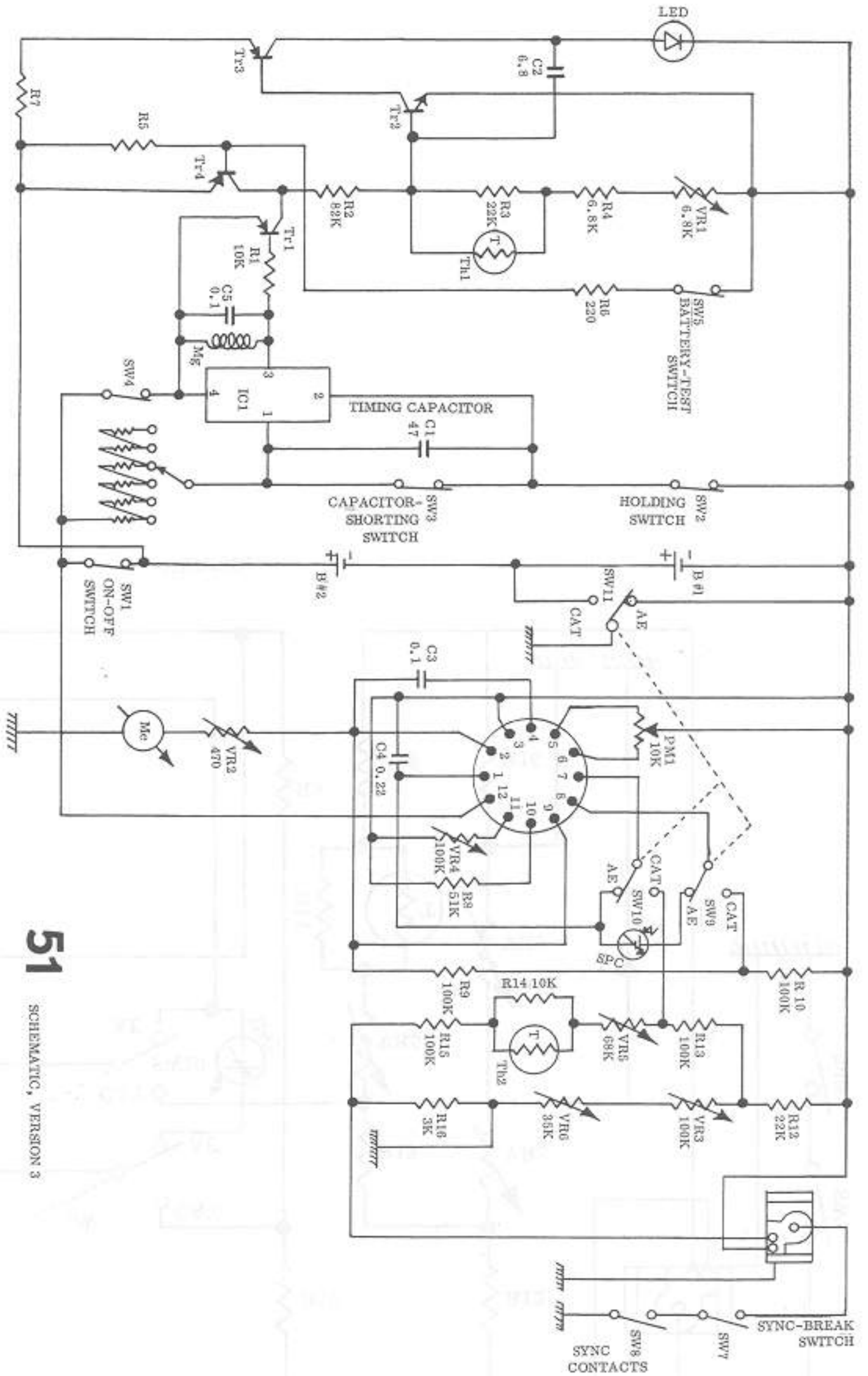

**51** SCHEMATIC, VERSION 3

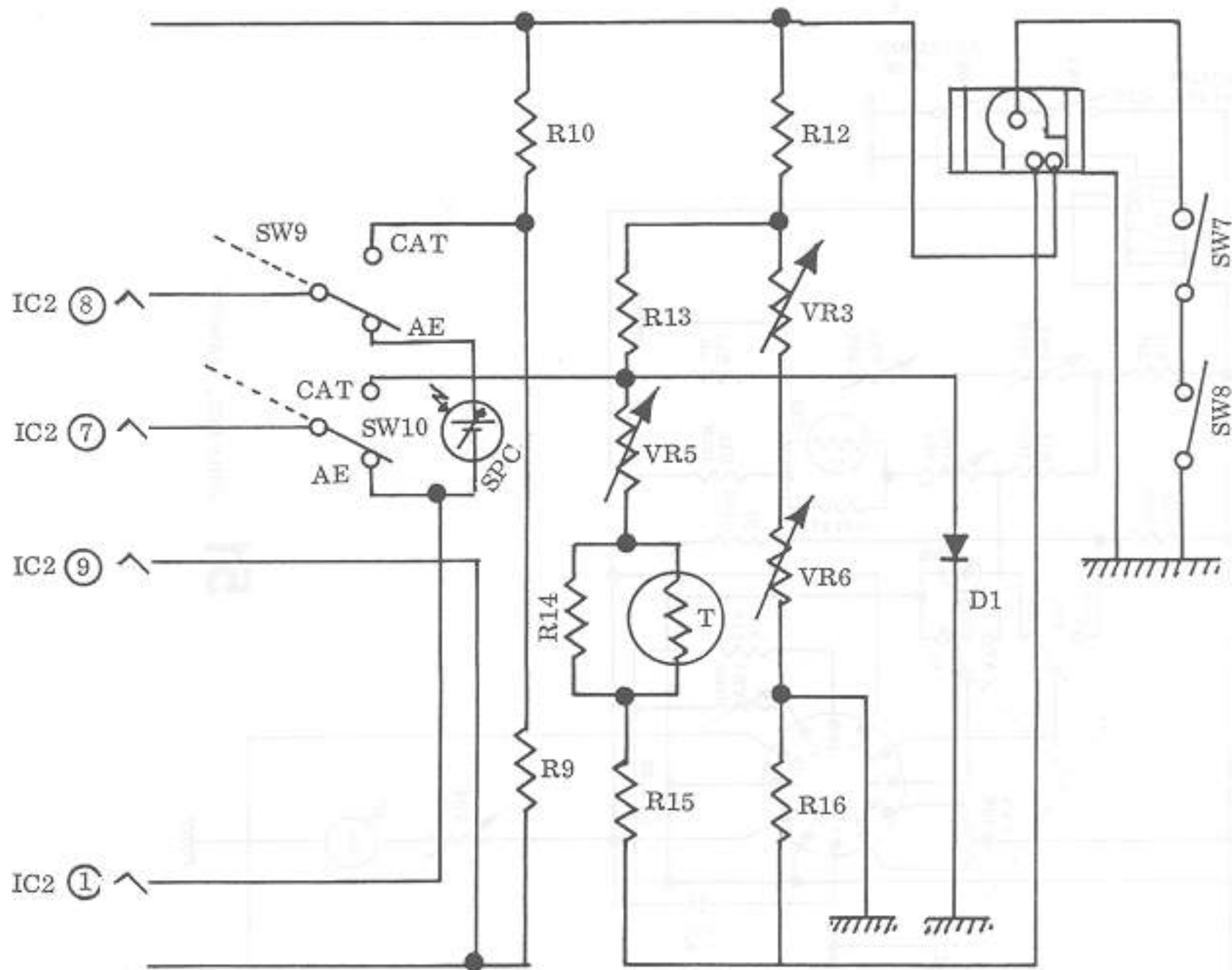

52

VERSION 4

VERSION #2 MODIFIED TO VERSION #4

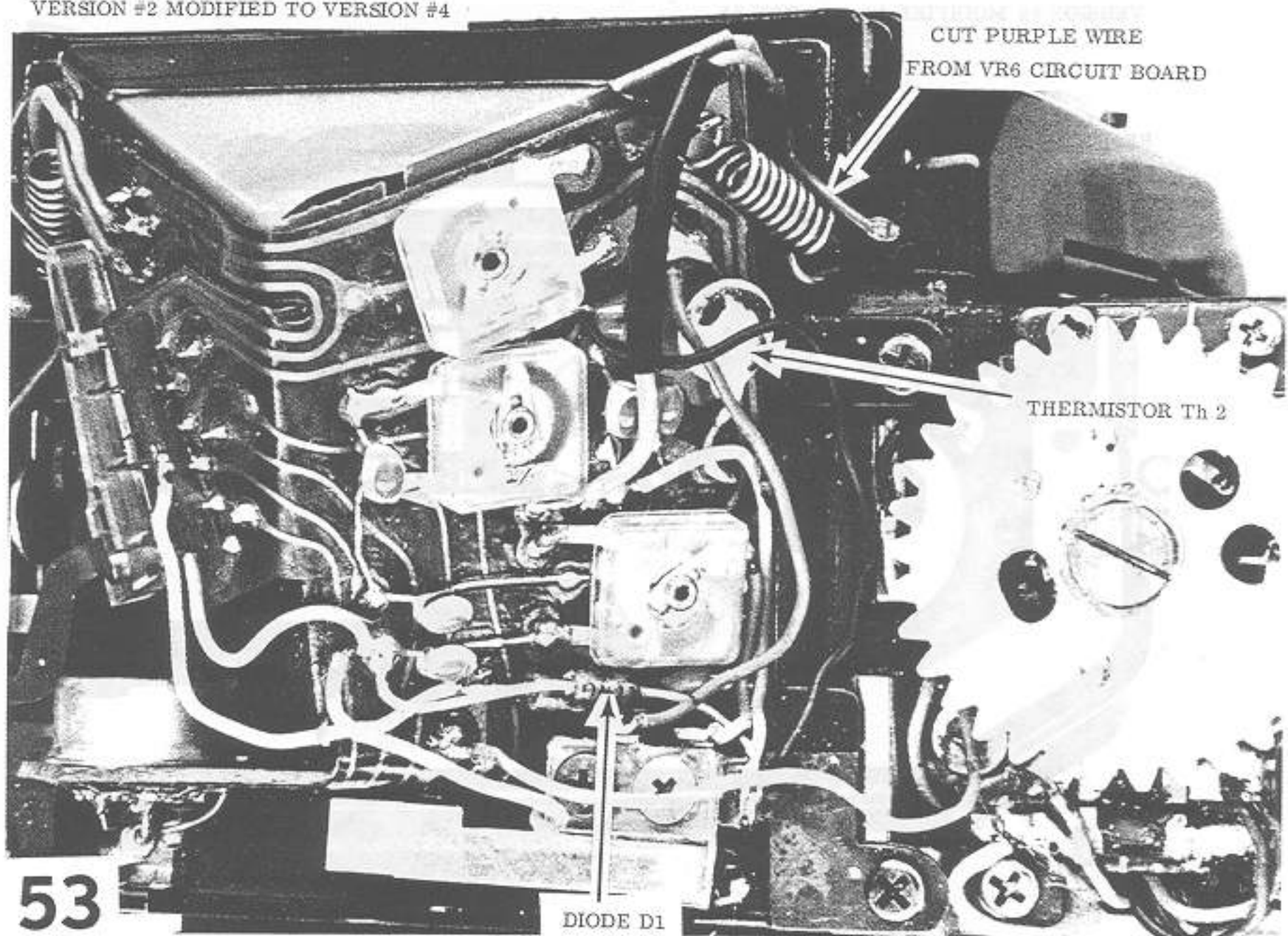

CUT PURPLE WIRE  
FROM VR6 CIRCUIT BOARD

THERMISTOR Th 2

DIODE D1

53

*↑*  
*Difference*

VERSION #2 MODIFIED TO VERSION #4

REMOVE FIXED RESISTOR AND THERMISTOR FROM VR6  
CIRCUIT BOARD

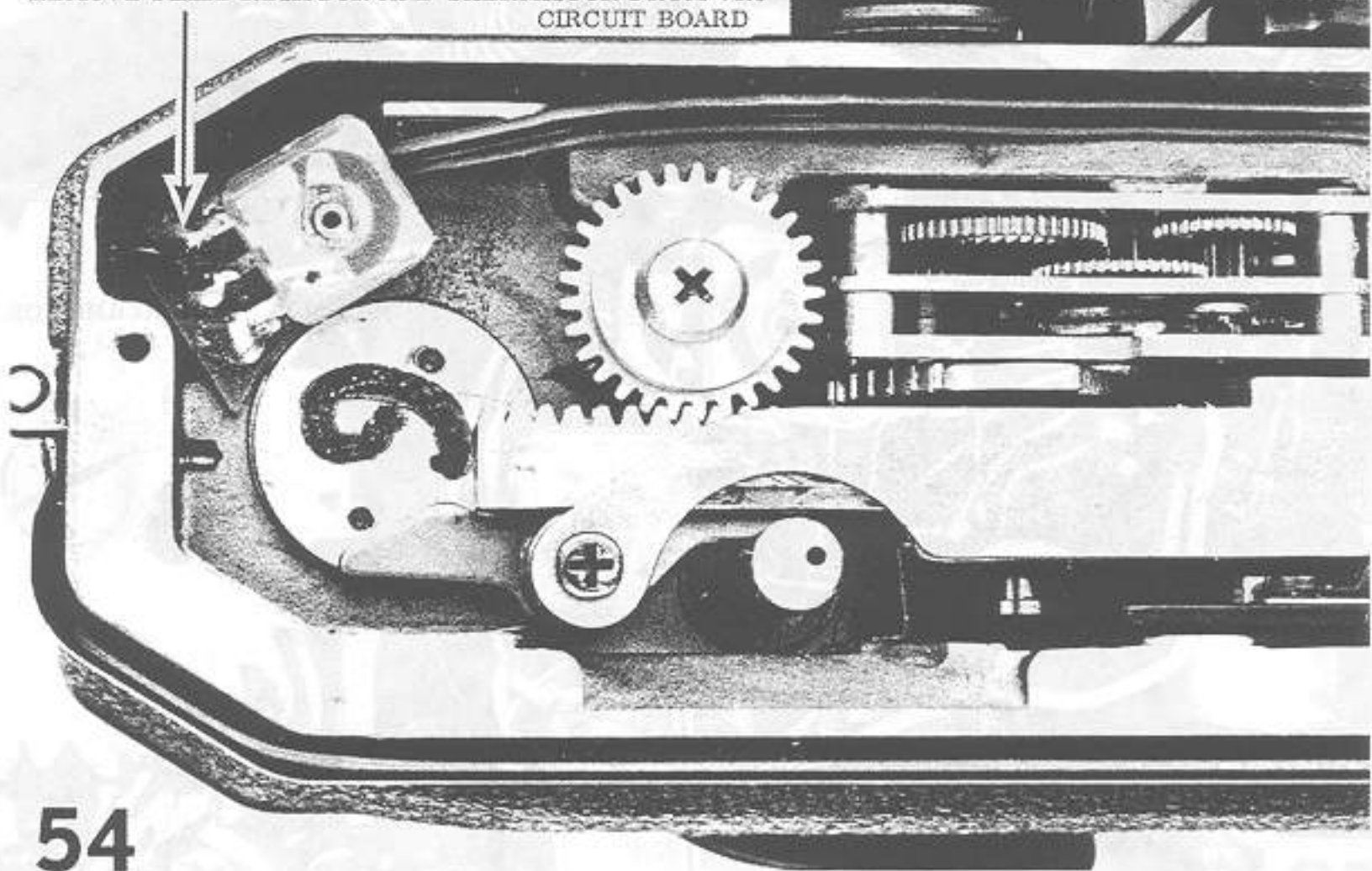

54

1. WEDGE CATS-NORMAL SWITCHING SLIDE TO KEEP CATS-NORMAL SWITCHES CLOSED

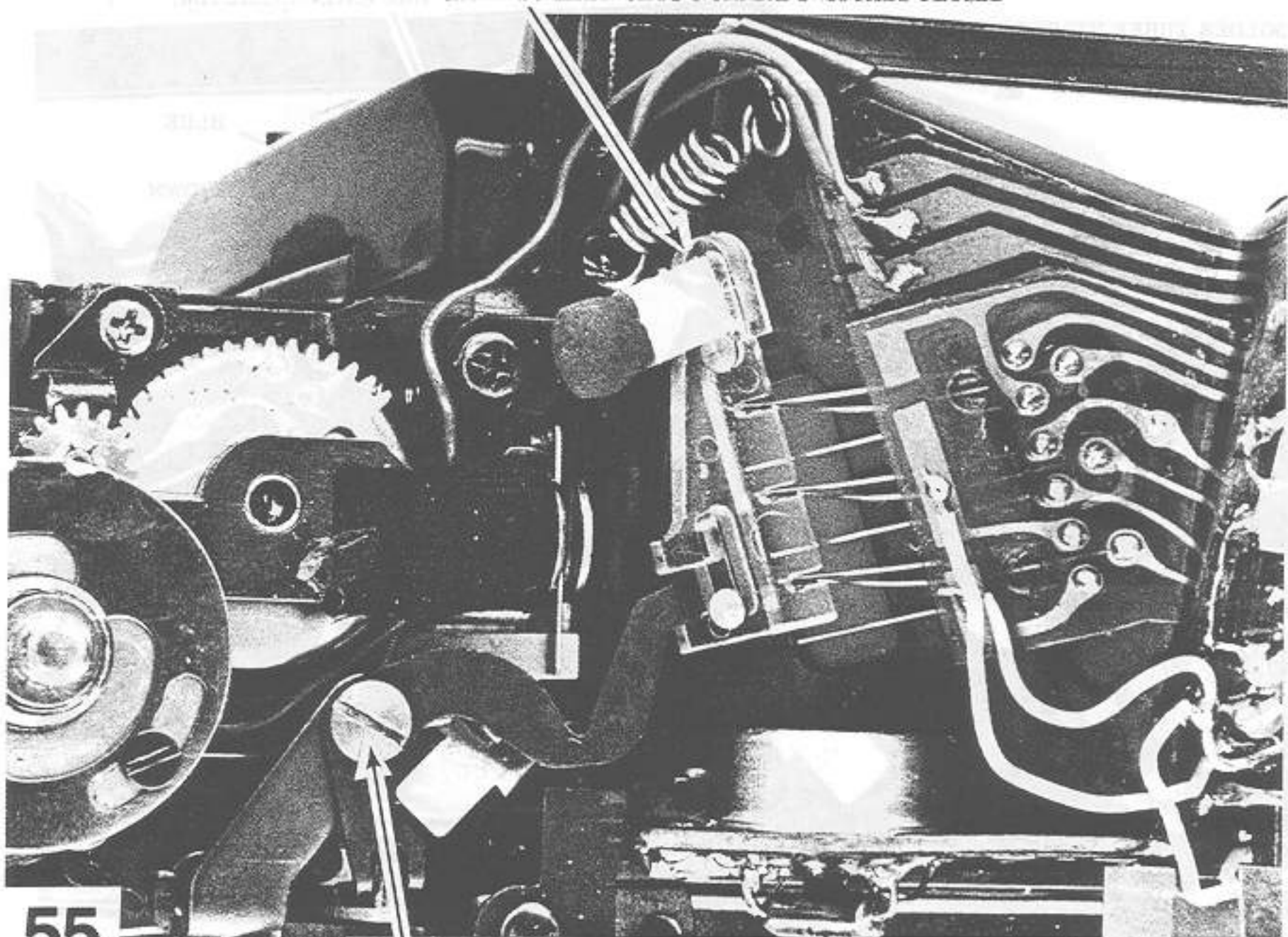

55

2. REMOVE SHOULDER SCREW AND TAKE OUT CATS-NORMAL SELECTOR LEVER

UNSOLDER THREE WIRES FROM  
PENTAPRISM CIRCUIT BOARD

RED (GALVANOMETER)

BLUE

BROWN

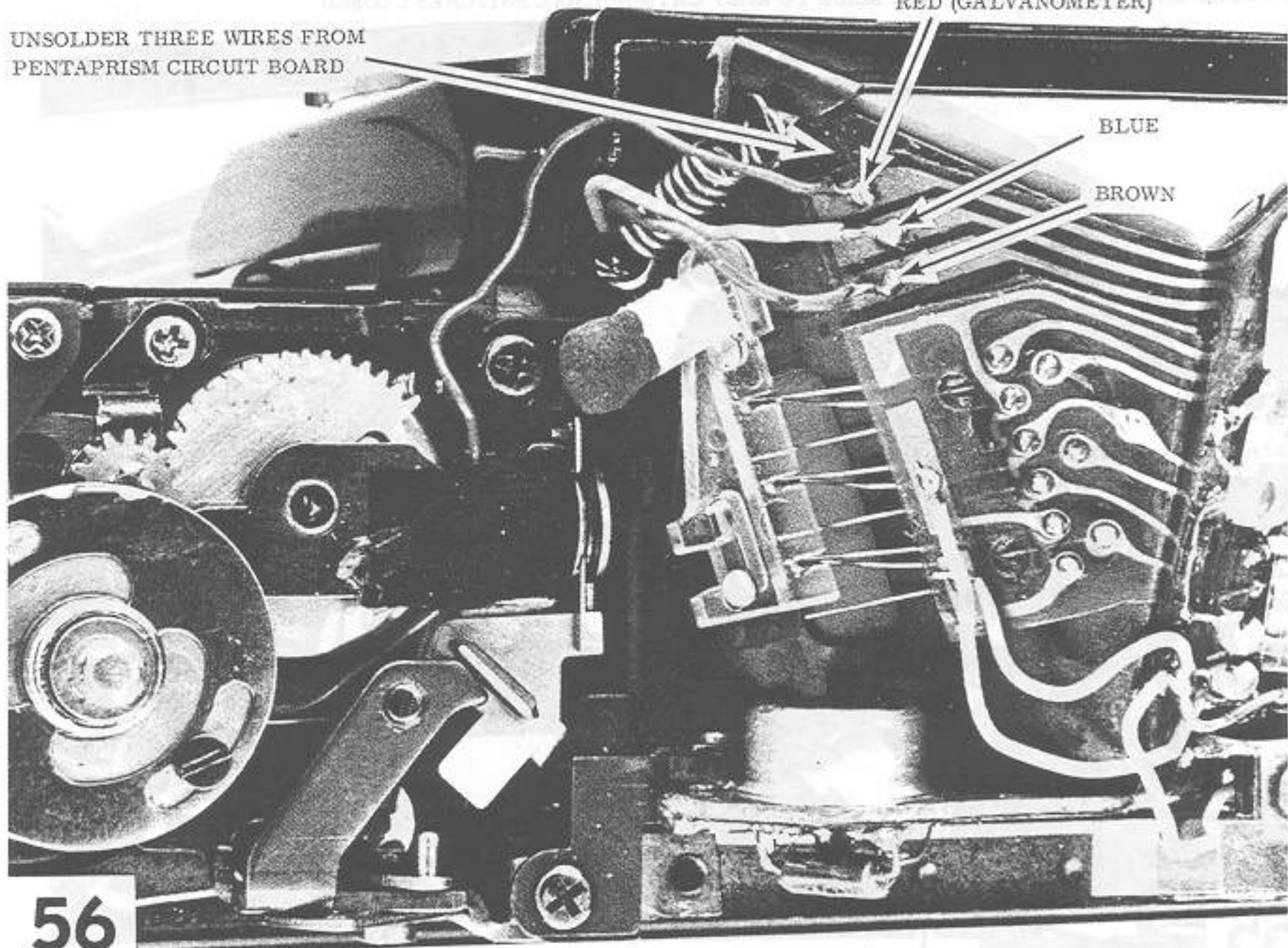

56

UNSOLDER TWO ORANGE WIRES FROM PENTAPRISM CIRCUIT BOARD

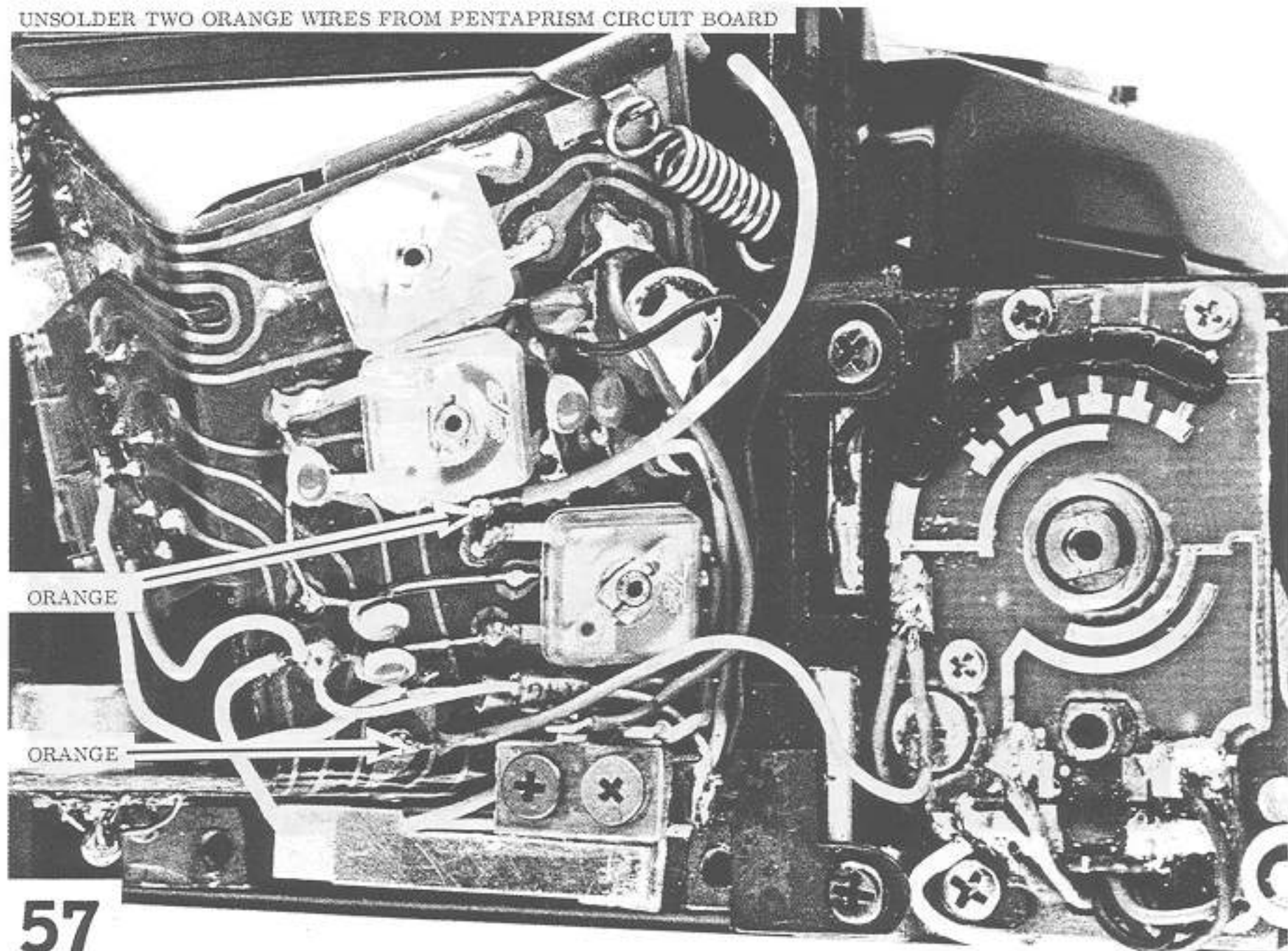

57

IN #2 VERSION, UNSOLDER PURPLE WIRE FROM VR5

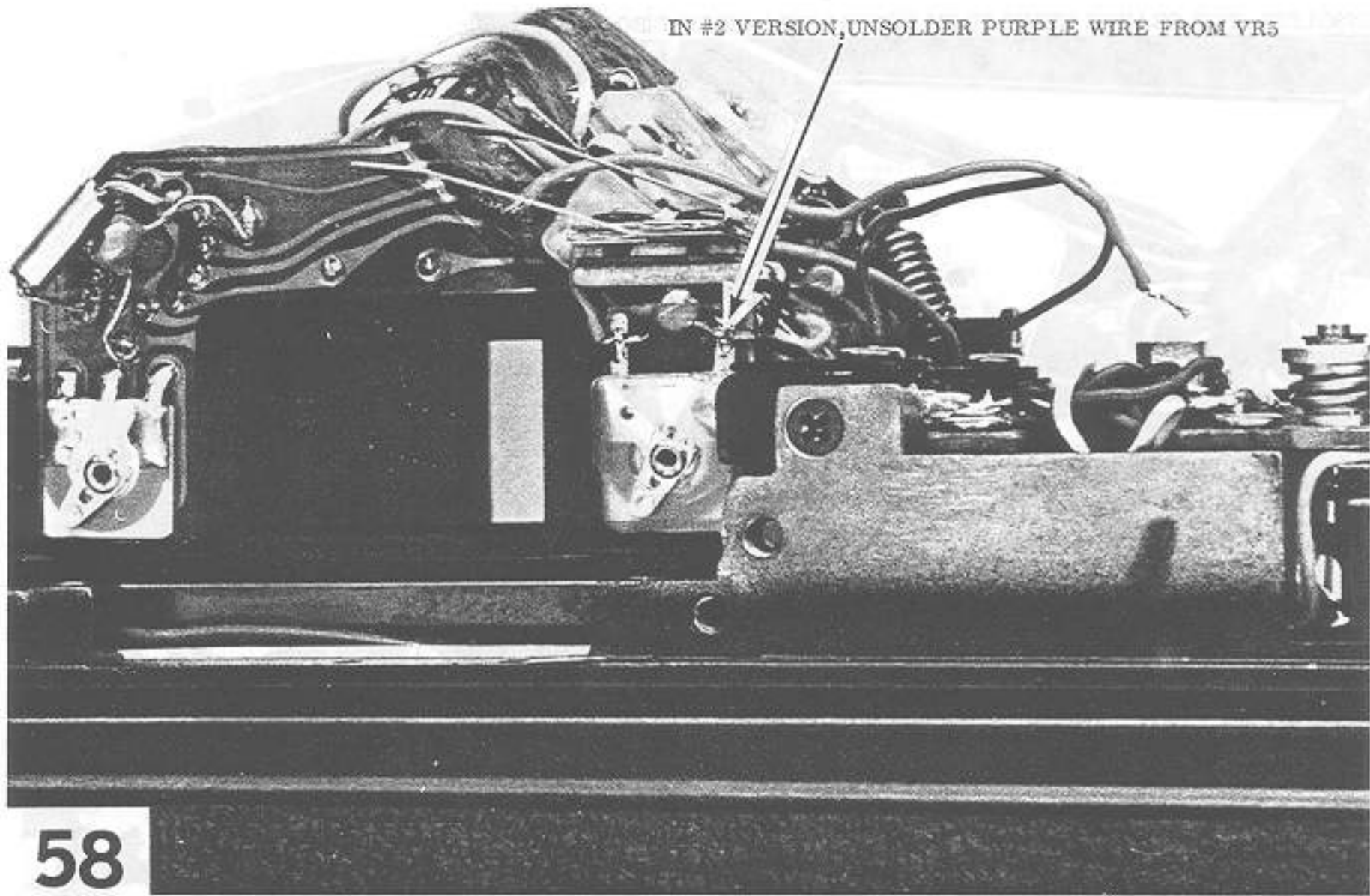

58

TO REMOVE PENTAPRISM CIRCUIT BOARD:

1. DISCONNECT SPRINGS AND LIFT OFF PRISM RETAINER

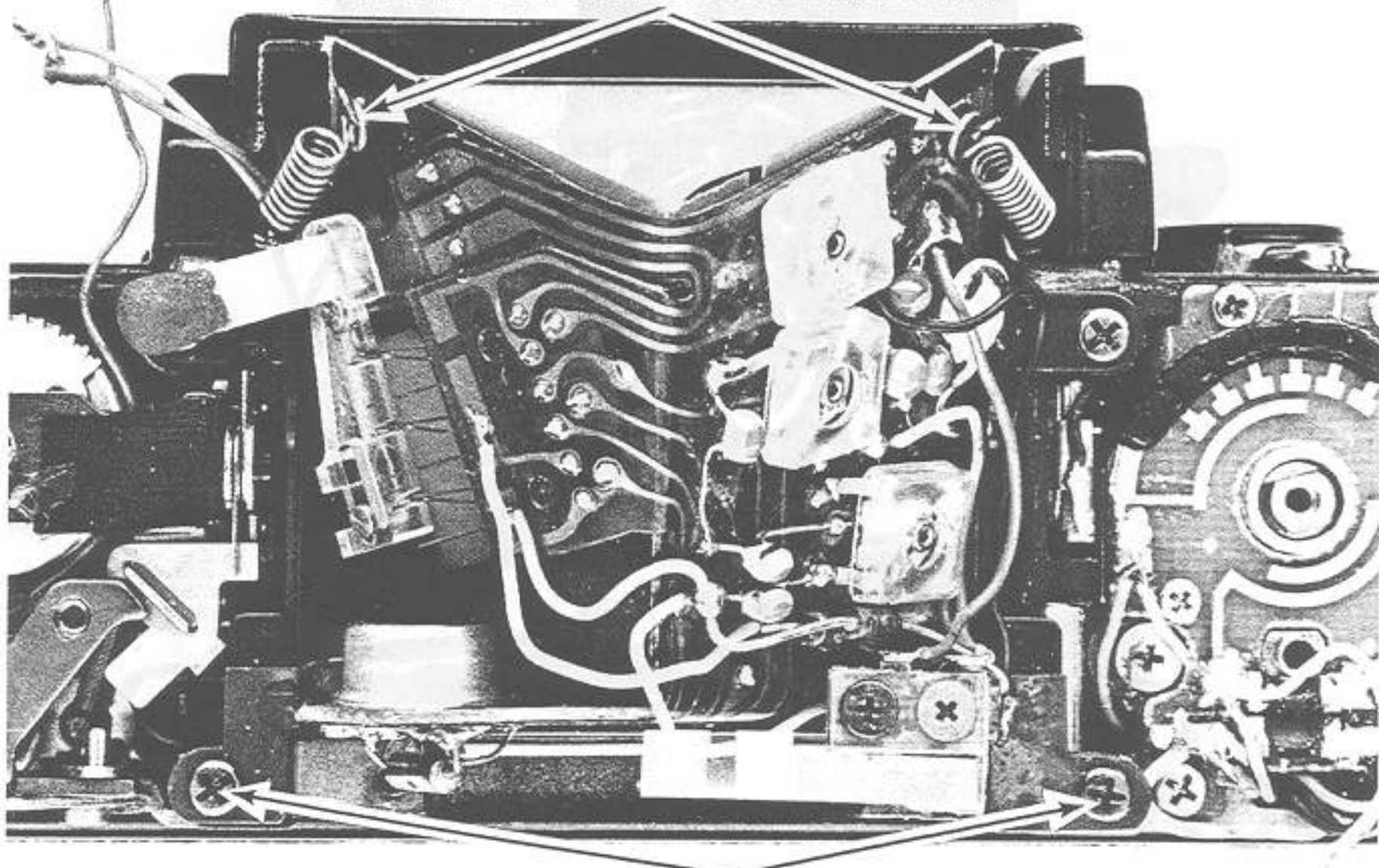

2. REMOVE TWO CIRCUIT-BOARD SCREWS  
3. LIFT OFF PENTAPRISM CIRCUIT BOARD

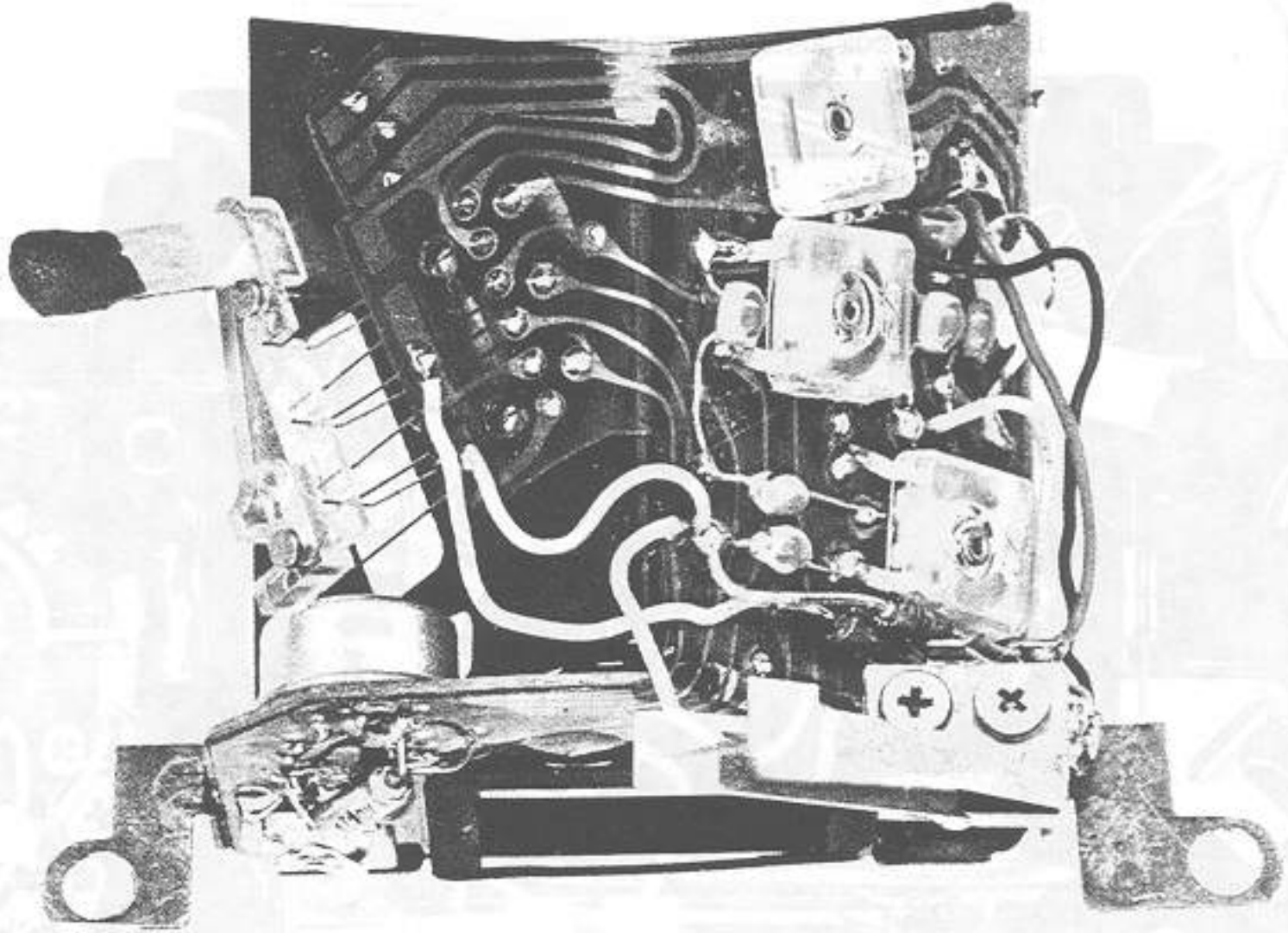

**60A**

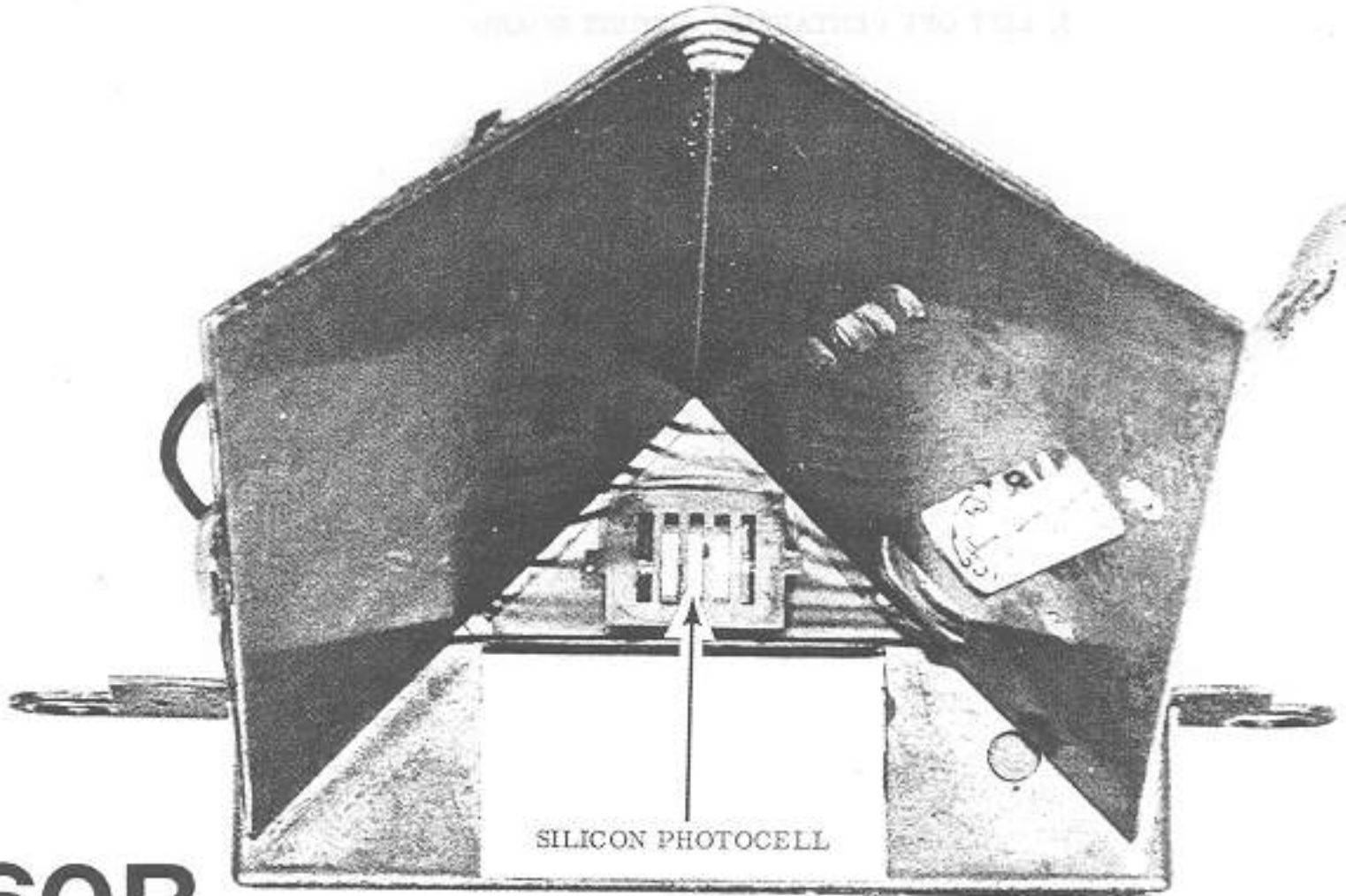

**60B**

TO REMOVE COMPLETE PENTAPRISM UNIT, TAKE OUT FOUR SCREWS

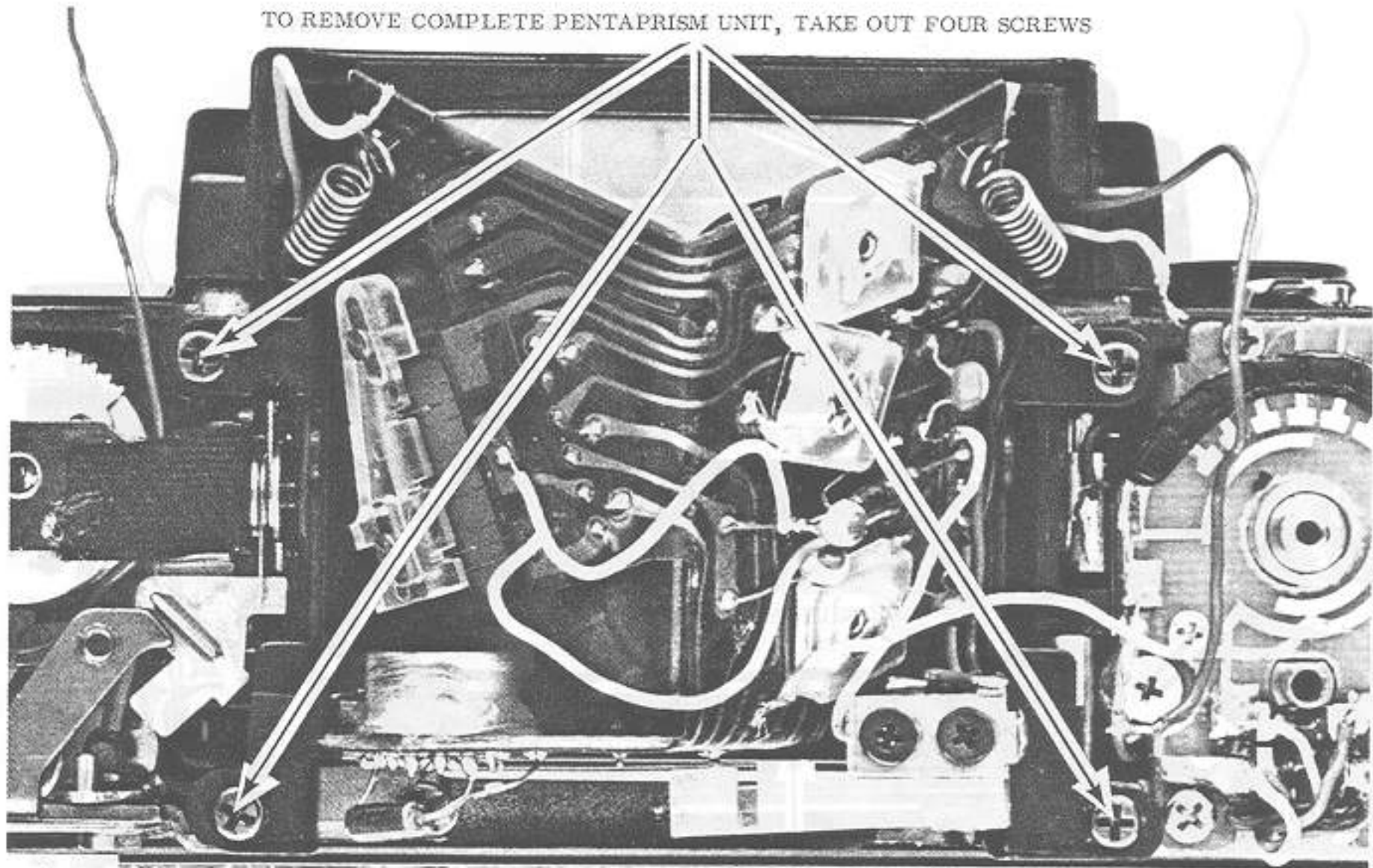

61

Copyright © 1961

28

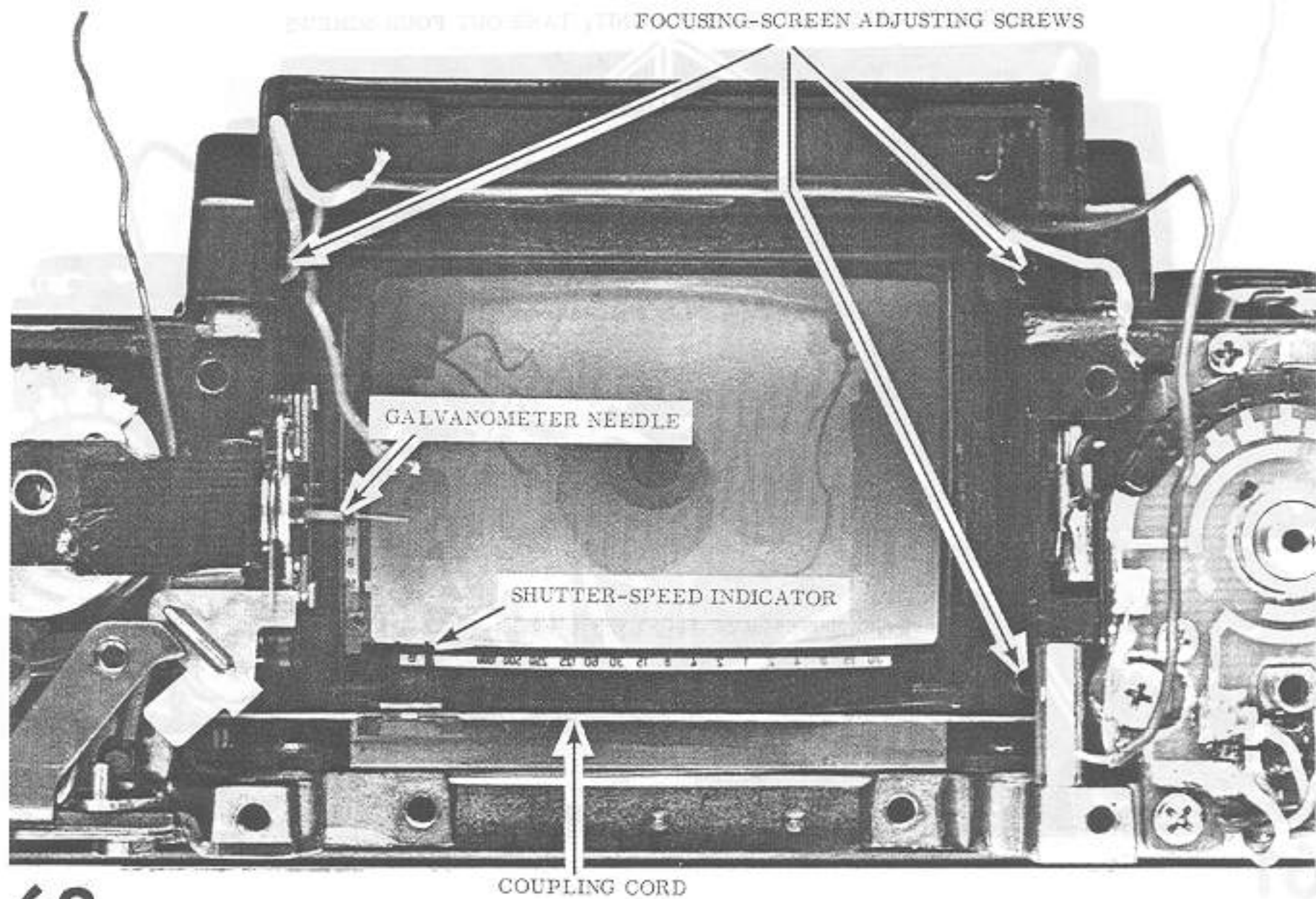

62

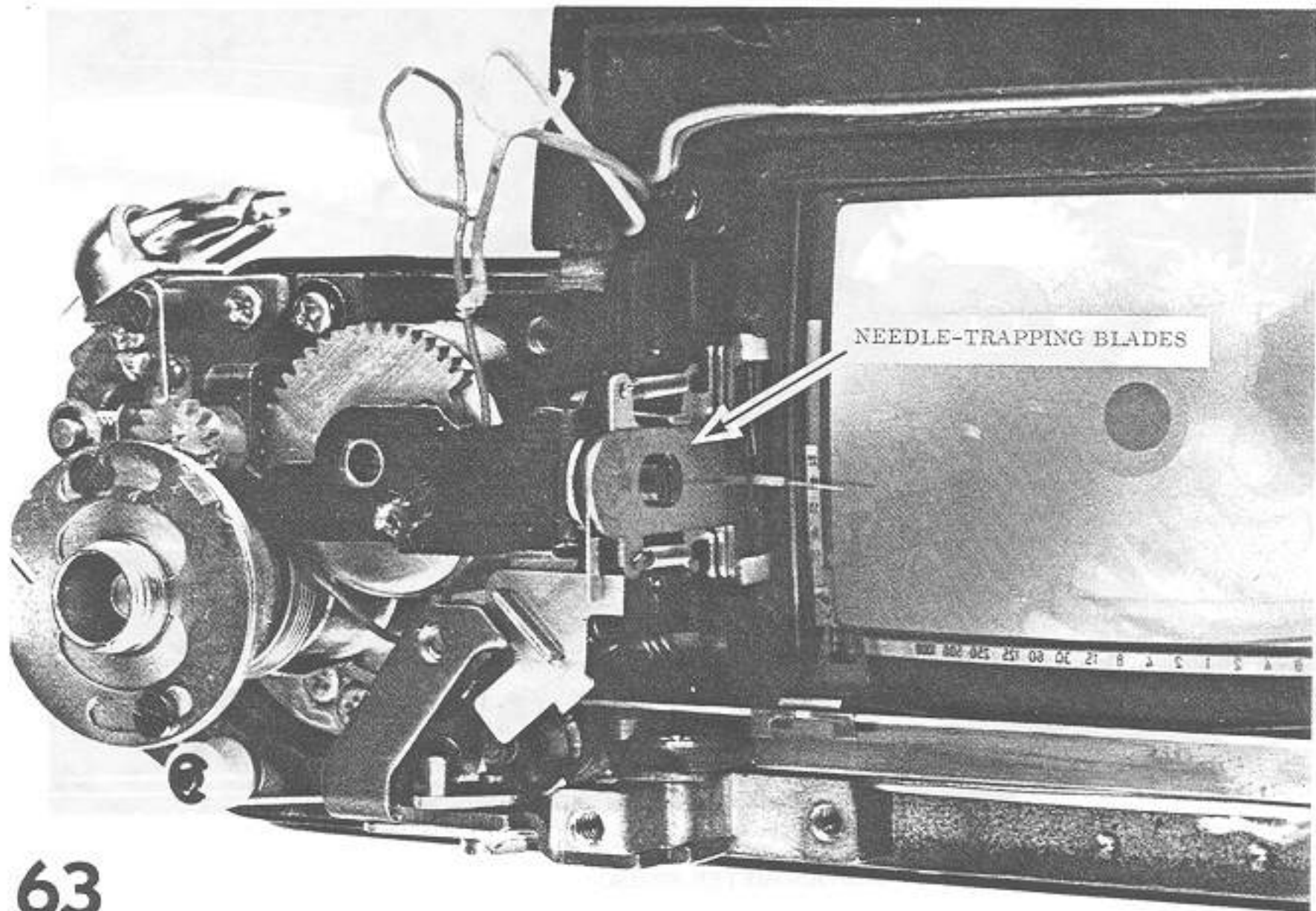

63

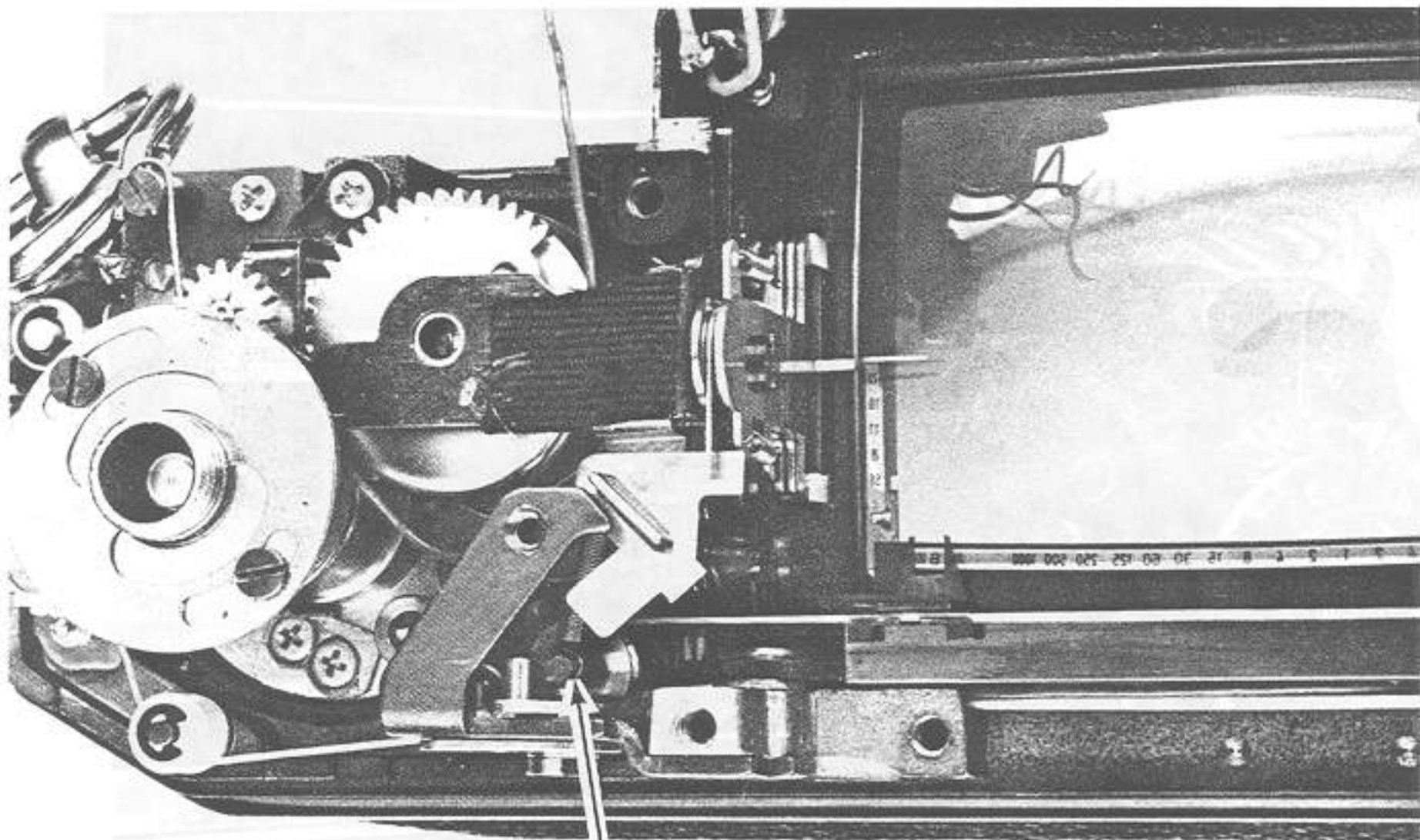

64

DISCONNECT GALVANOMETER SPRING

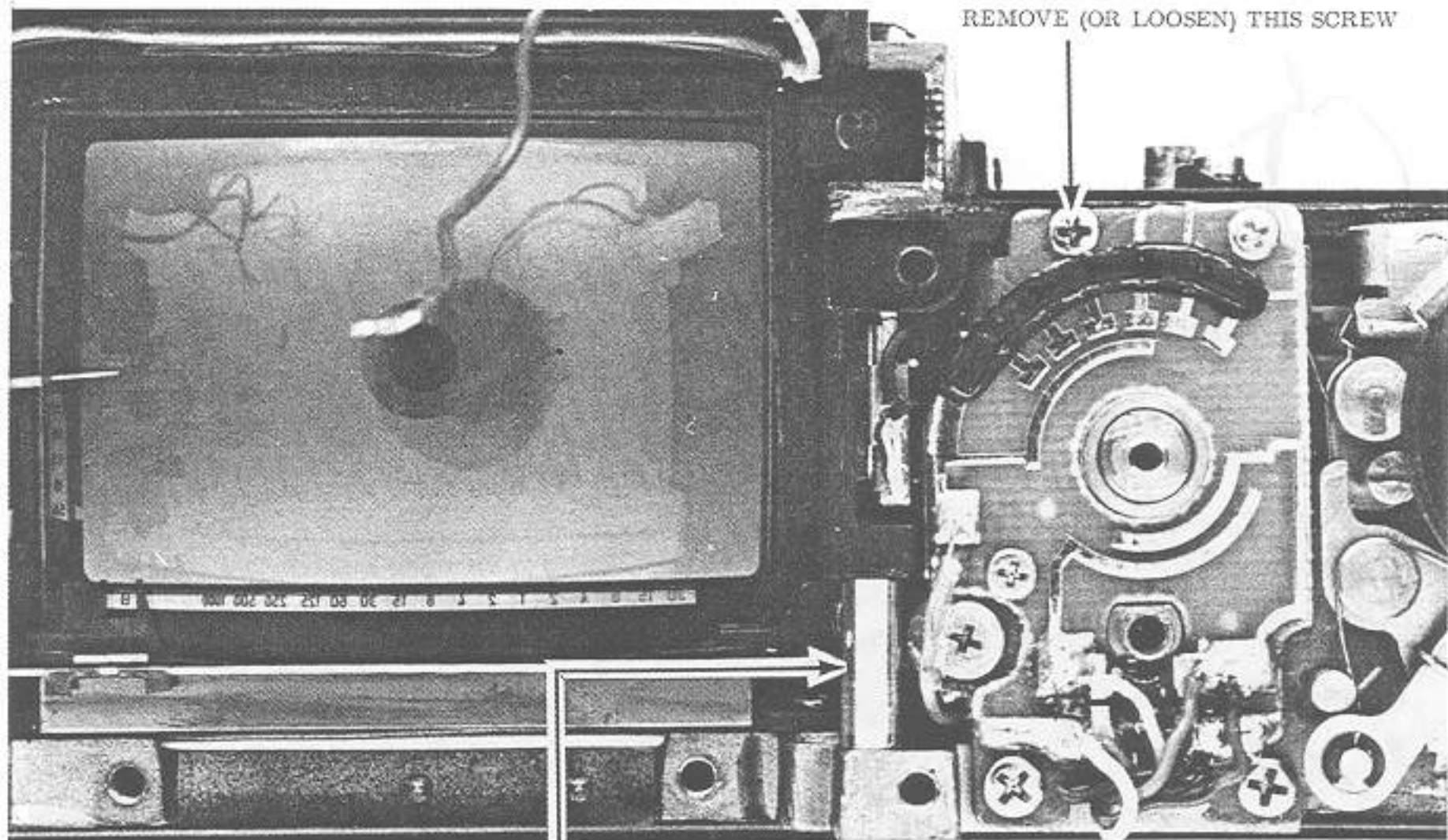

REMOVE (OR LOOSEN) THIS SCREW

65

NOTE SPACER BETWEEN MIRROR CAGE AND CAMERA BODY -- SPACER WILL BE LOOSE WHEN YOU REMOVE THE SCREW SHOWN IN THE NEXT ILLUSTRATION

REMOVE SCREW AND SPACER

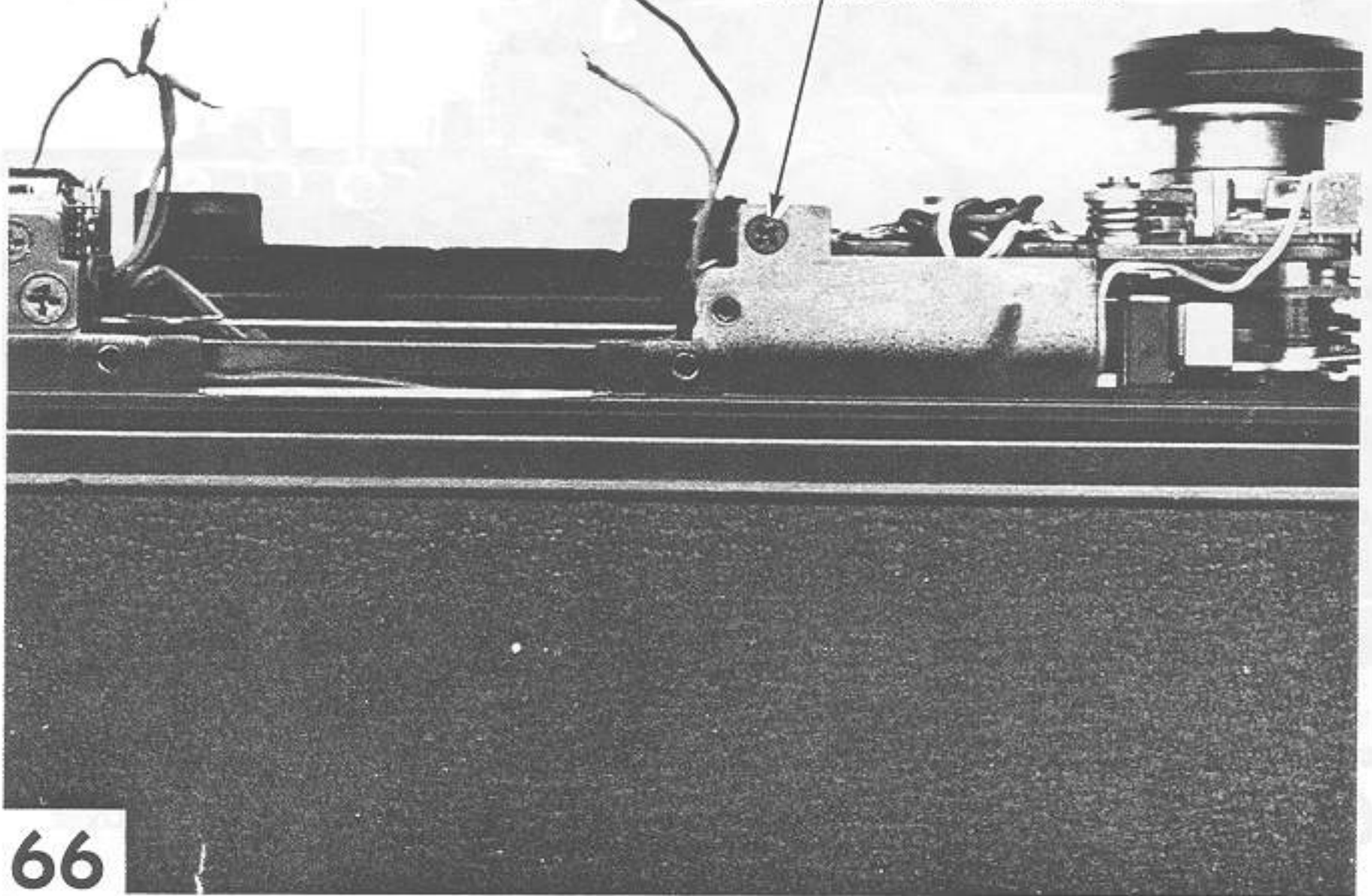

66

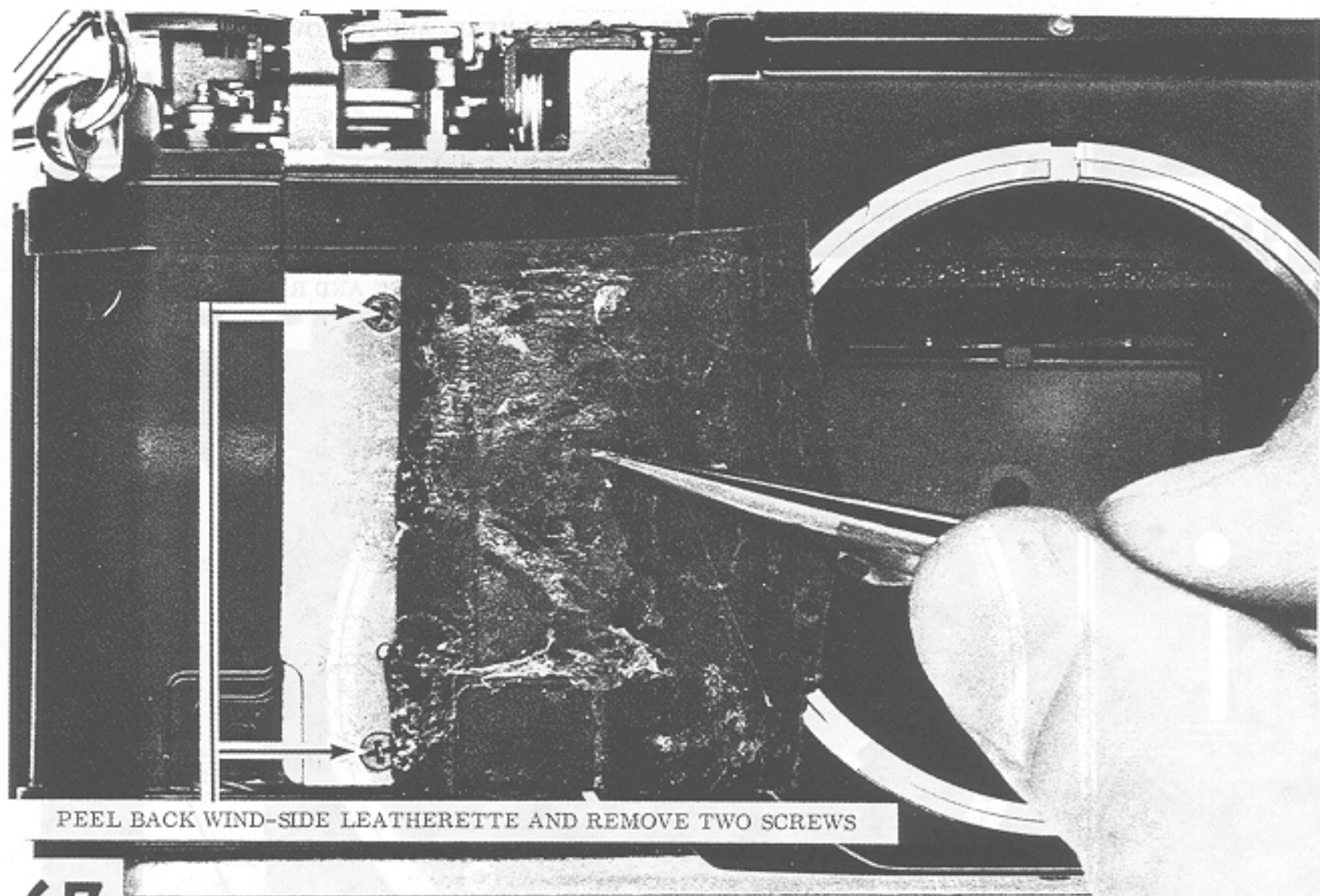

PEEL BACK WIND-SIDE LEATHERETTE AND REMOVE TWO SCREWS

67

88

1. PEEL BACK CORNER OF WIND-SIDE LEATHERETTE (SHOWN CUTAWAY HERE) AND REMOVE SCREW

2. PEEL BACK REWIND-SIDE LEATHERETTE AND REMOVE TWO SCREWS

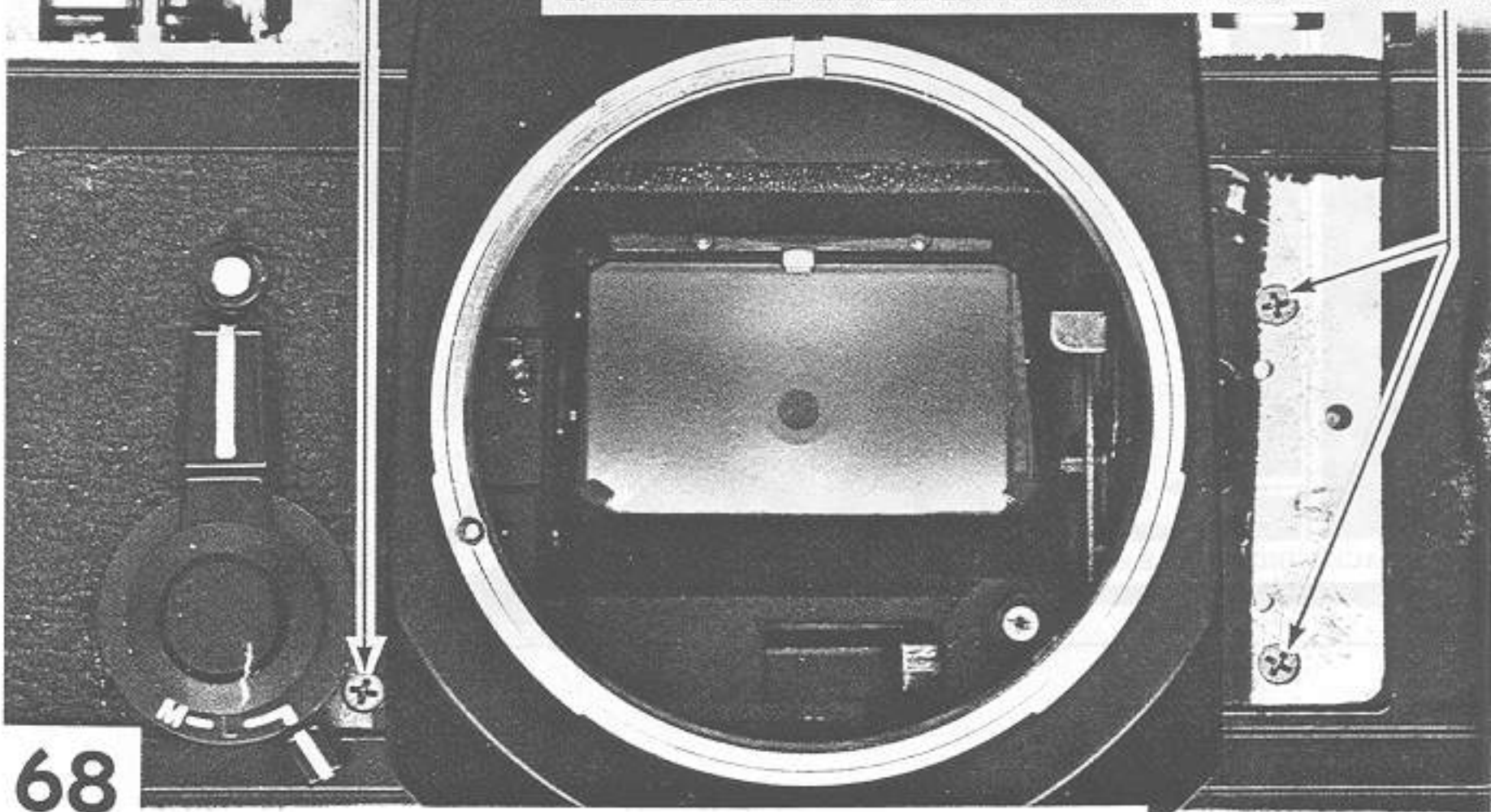

3. LIFT OUT FRONT-PLATE/MIRROR-CAGE ASSEMBLY

*Shutter can be released when replacing front plate*

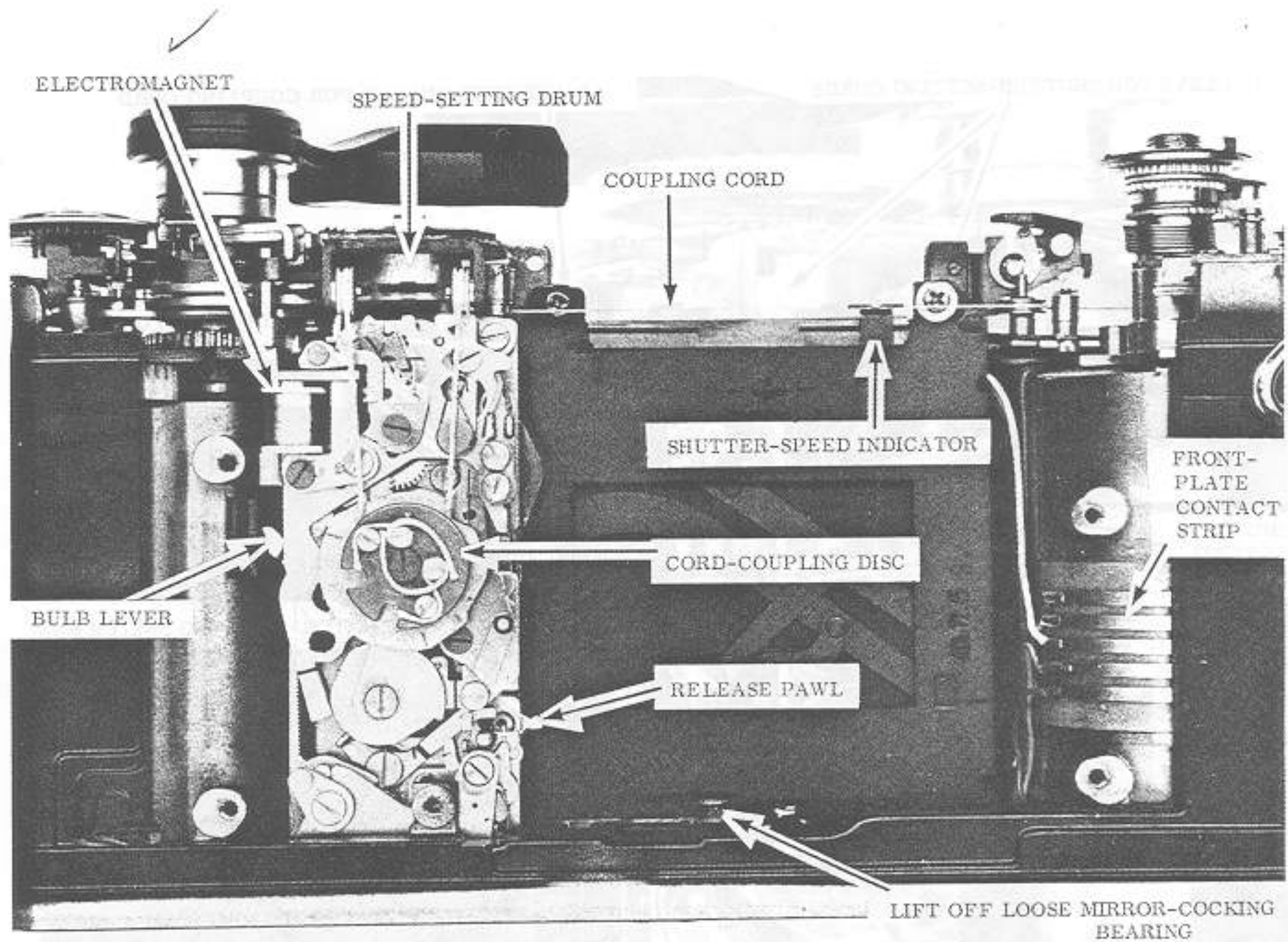

69

SHUTTER SET TO "BULB"

*check for stuck elec magnet if shutter is open*

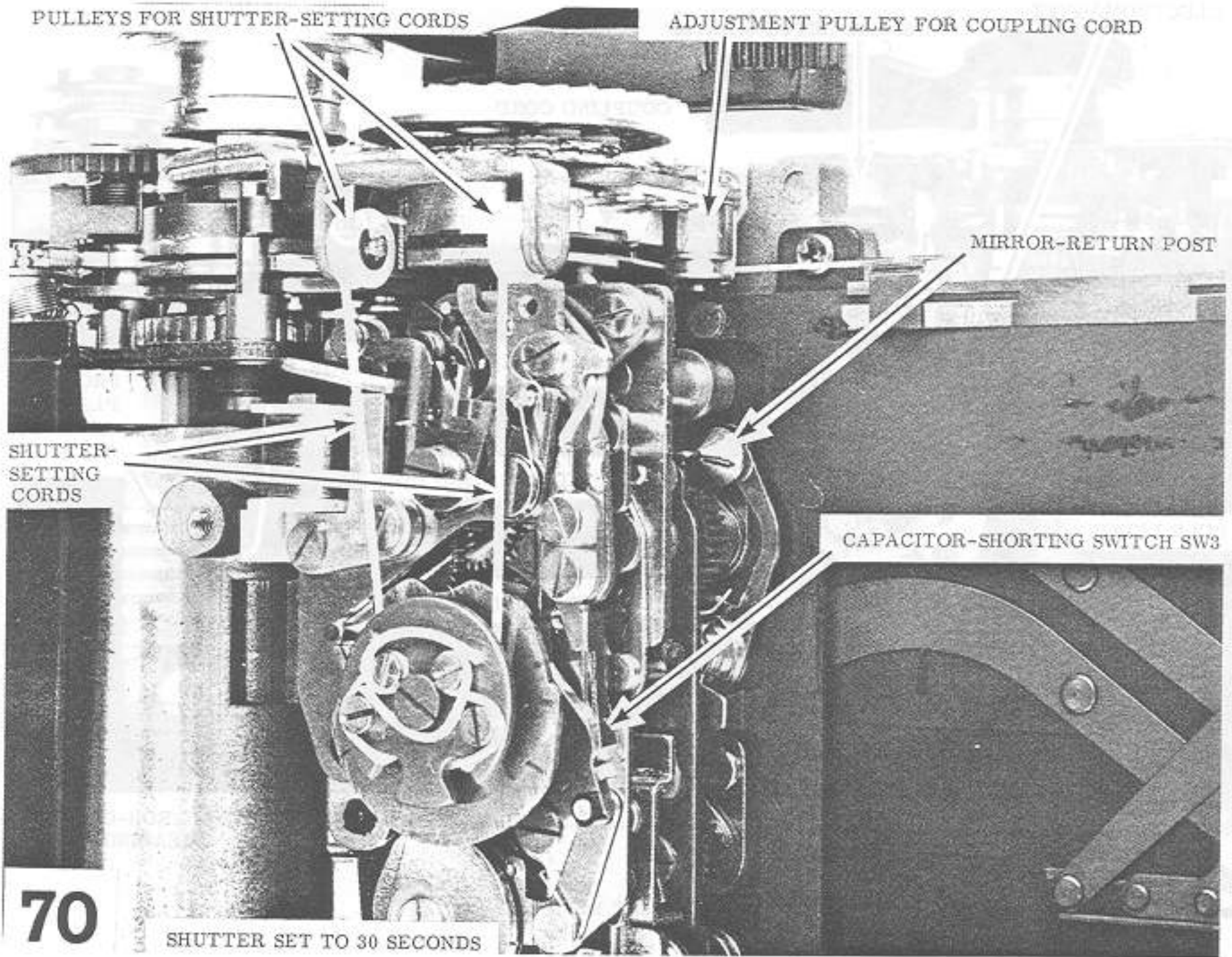

PULLEYS FOR SHUTTER-SETTING CORDS

ADJUSTMENT PULLEY FOR COUPLING CORD

MIRROR-RETURN POST

SHUTTER-SETTING CORDS

CAPACITOR-SHORTING SWITCH SW3

70

SHUTTER SET TO 30 SECONDS

*Handwritten text at the bottom of the page, likely a page number or reference note.*

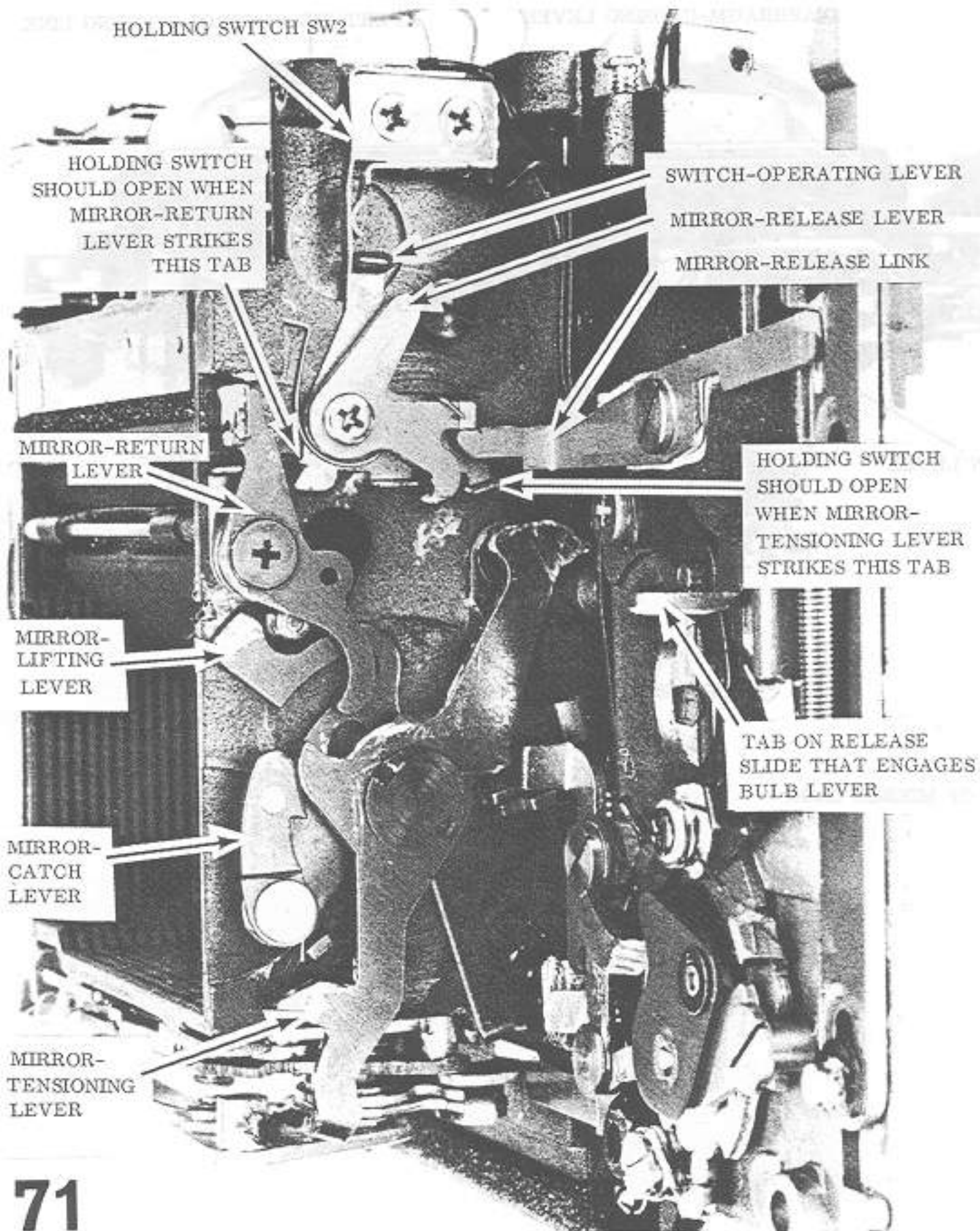

HOLDING SWITCH SW2

HOLDING SWITCH SHOULD OPEN WHEN MIRROR-RETURN LEVER STRIKES THIS TAB

SWITCH-OPERATING LEVER

MIRROR-RELEASE LEVER

MIRROR-RELEASE LINK

MIRROR-RETURN LEVER

HOLDING SWITCH SHOULD OPEN WHEN MIRROR-TENSIONING LEVER STRIKES THIS TAB

MIRROR-LIFTING LEVER

TAB ON RELEASE SLIDE THAT ENGAGES BULB LEVER

MIRROR-CATCH LEVER

MIRROR-TENSIONING LEVER

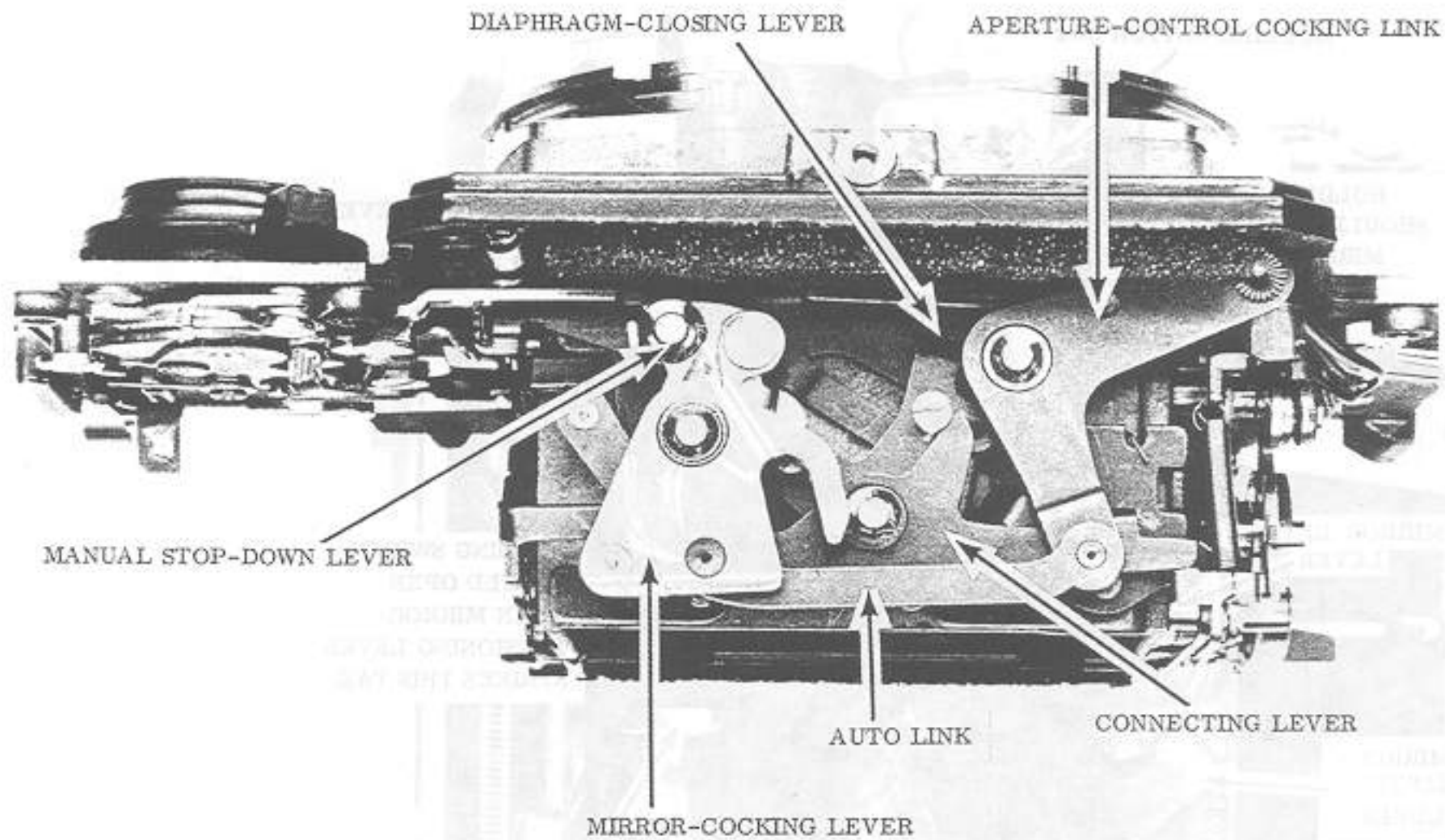

**72**

BOTTOM OF MIRROR CAGE

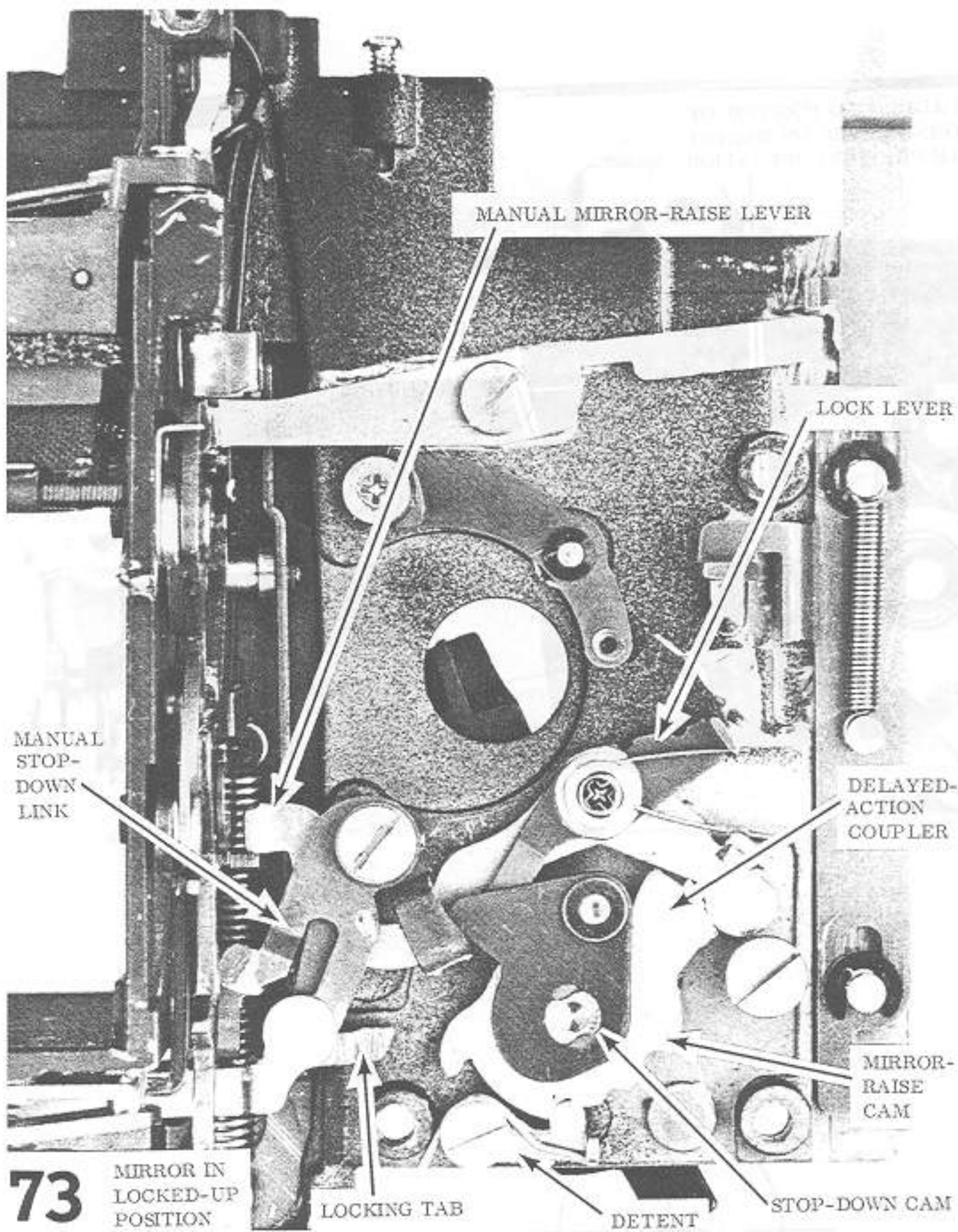

MANUAL MIRROR-RAISE LEVER

LOCK LEVER

MANUAL  
STOP-  
DOWN  
LINK

DELAYED-  
ACTION  
COUPLER

MIRROR-  
RAISE  
CAM

**73**

MIRROR IN  
LOCKED-UP  
POSITION

LOCKING TAB

DETENT

STOP-DOWN CAM

ECCENTRIC FOR ADJUSTING POSITION OF  
DIAPHRAGM-CLOSING LEVER ON MANUAL  
(DEPTH-OF-FIELD PREVIEW) OPERATION

ECCENTRIC FOR ADJUSTING POSITION  
OF DIAPHRAGM-CLOSING LEVER ON  
NORMAL OPERATION

74

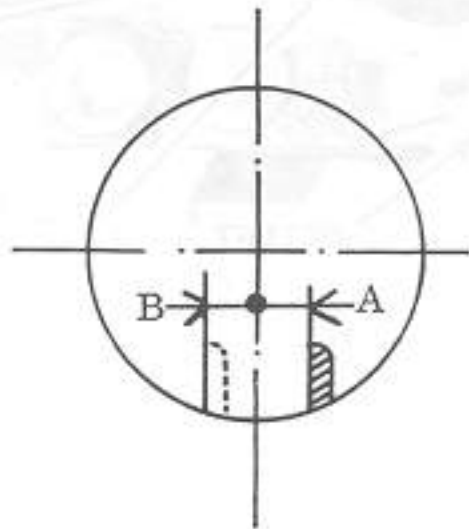

A = more than 5.5 mm

B = 1.8 — 3.2 mm

MAXIMUM-APERTURE  
CORRECTION LEVER

RELEASE  
PAWL

GOVERNOR  
DRUM

APERTURE-  
COCKING  
LEVER

MAXIMUM-  
APERTURE  
SET LEVER

75

AUTO-RELEASE LEVER

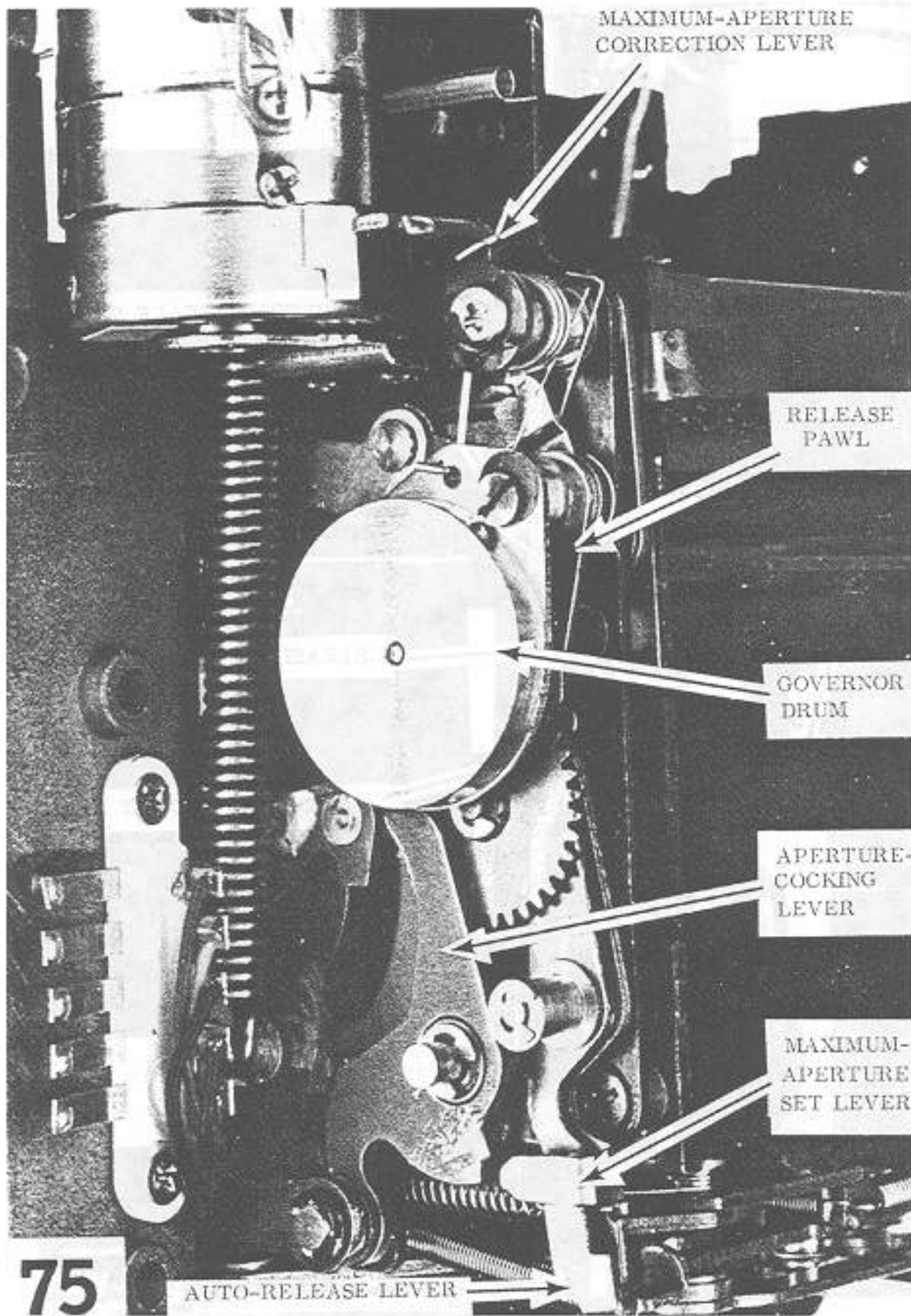

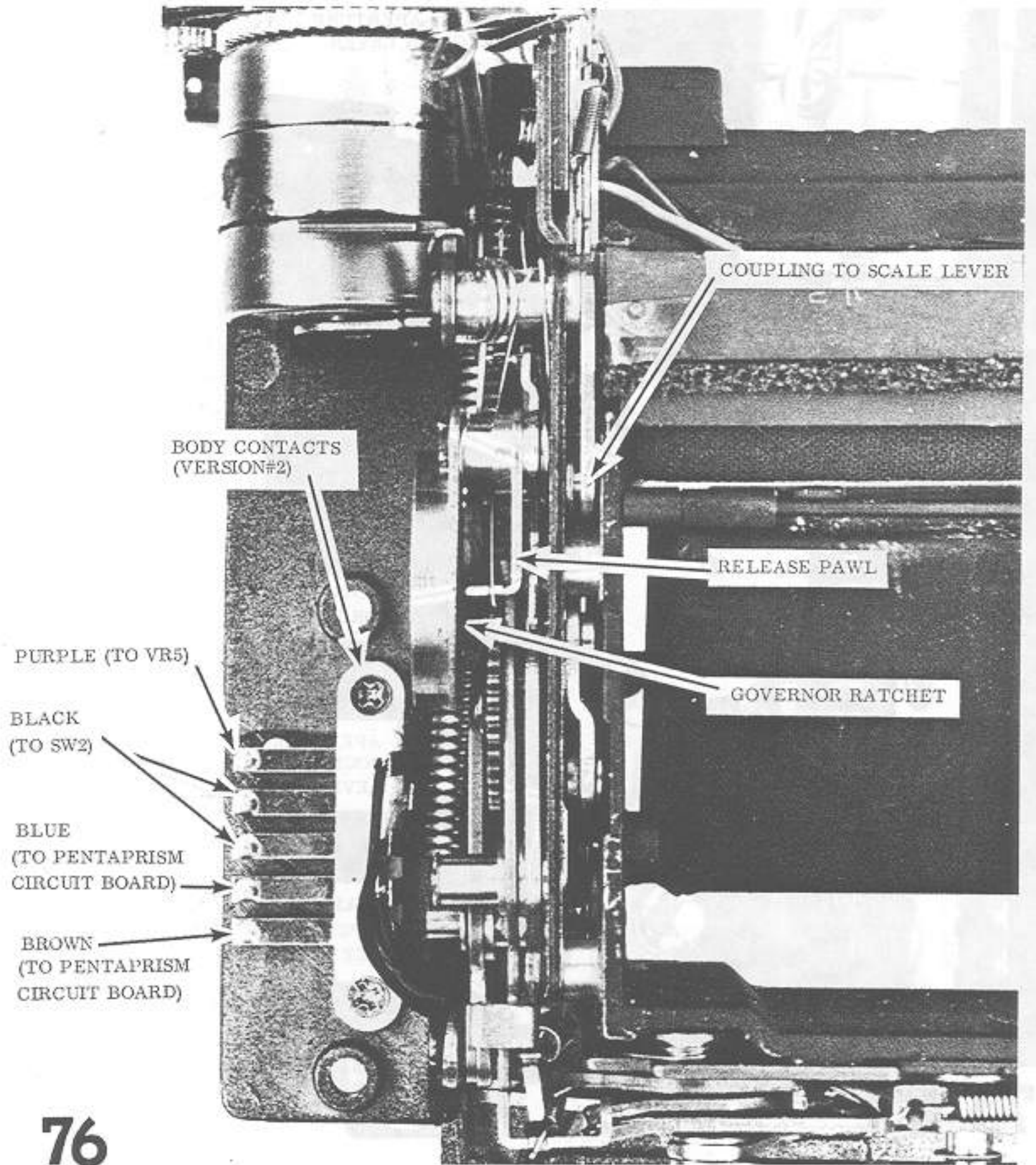

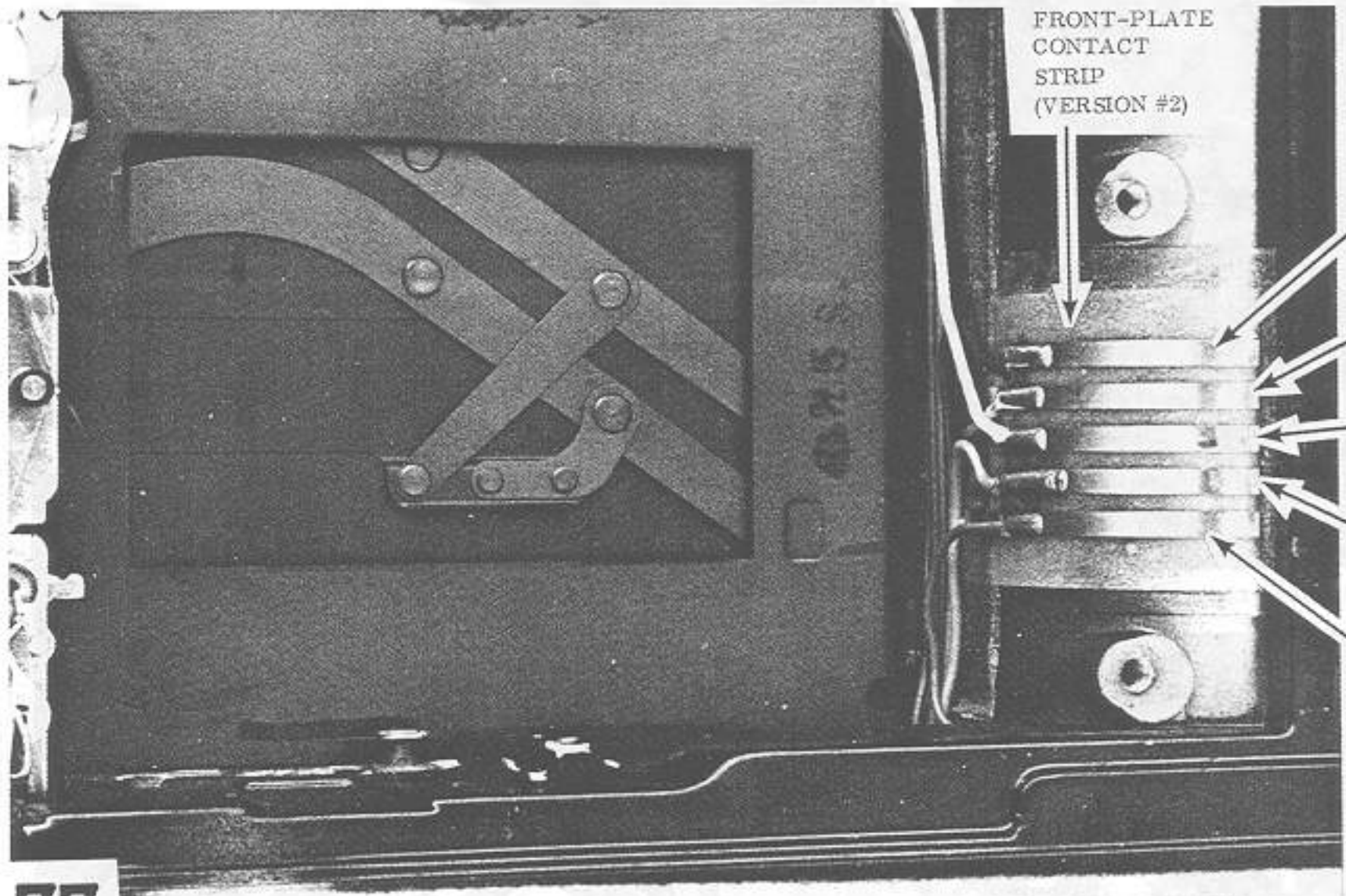

FRONT-PLATE  
CONTACT  
STRIP  
(VERSION #2)

PURPLE  
(TO Th2)

ORANGE  
(TO VR6)

WHITE  
(TO IC1)

LIGHT  
BLUE  
(TO VR1)

BROWN  
(TO CENTER  
BATTERY)

77

87

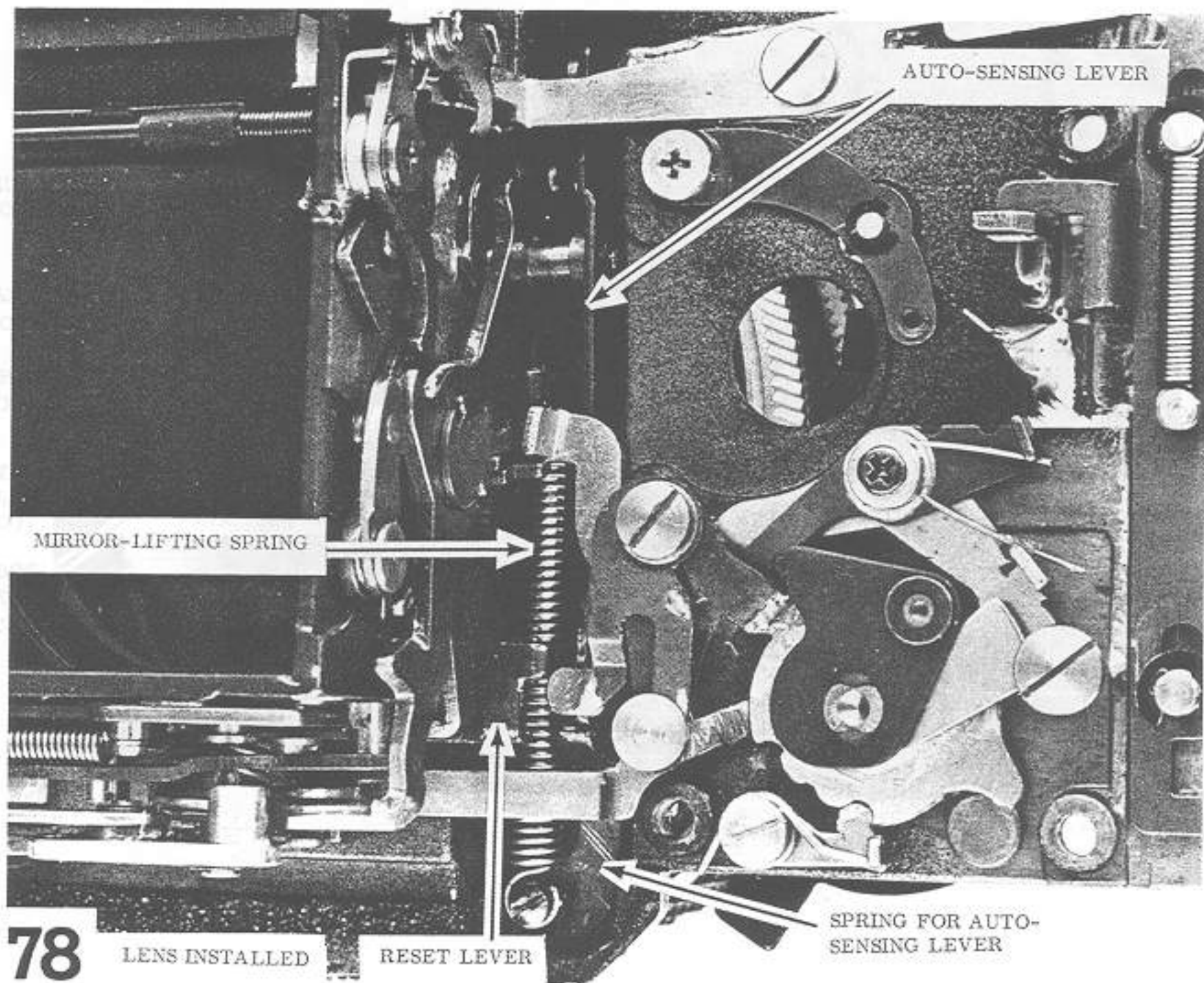

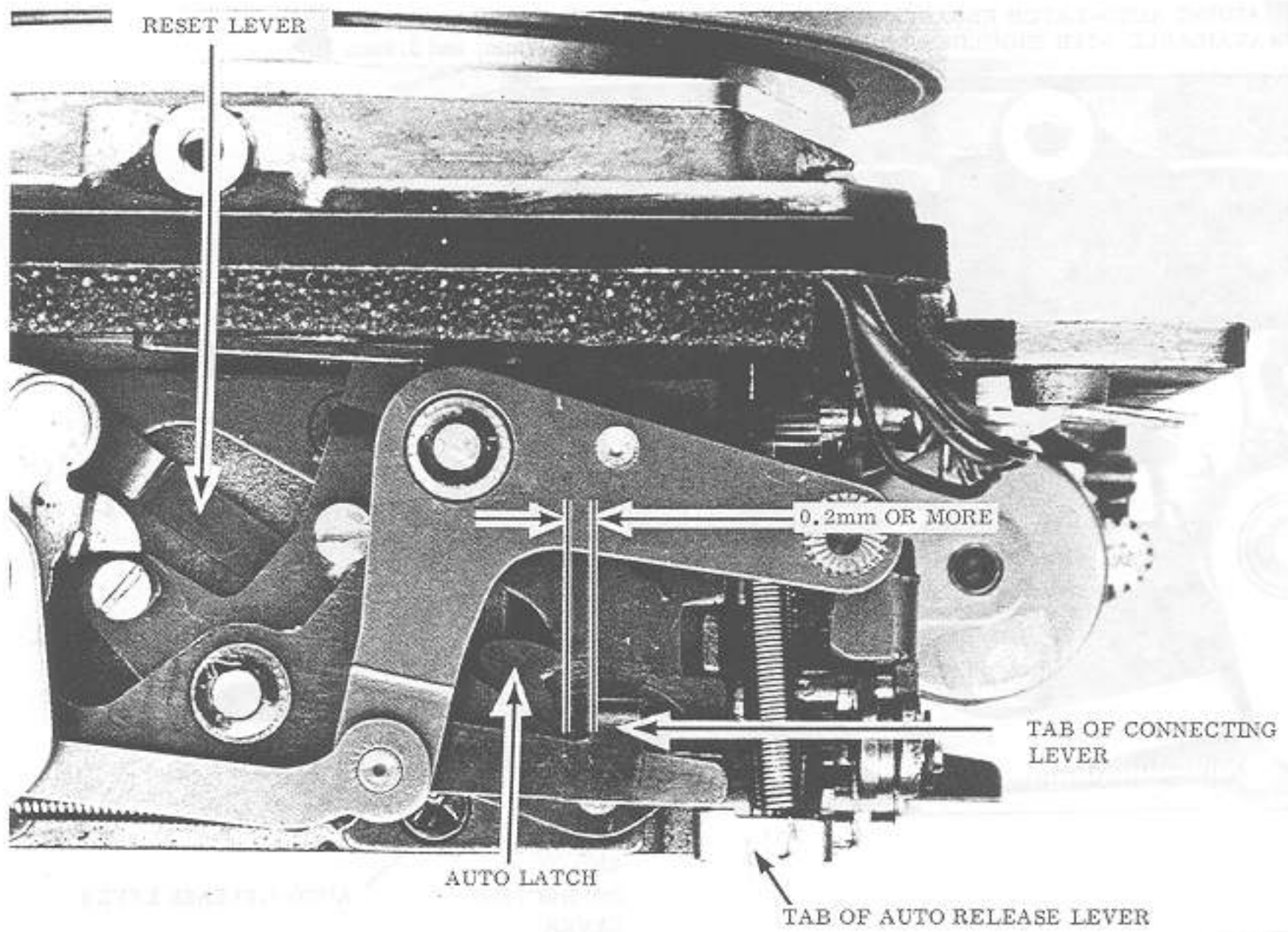

**79**

DIAPHRAGM-SETTING RING AT MANUAL SETTING

08

ADJUST AUTO-LATCH ENGAGEMENT WITH E-M CHANGE PIN (PART #19-0807) ---  
AVAILABLE WITH SHOULDER LENGTHS OF 3.3mm, 3.5mm, 3.7mm, and 3.9mm

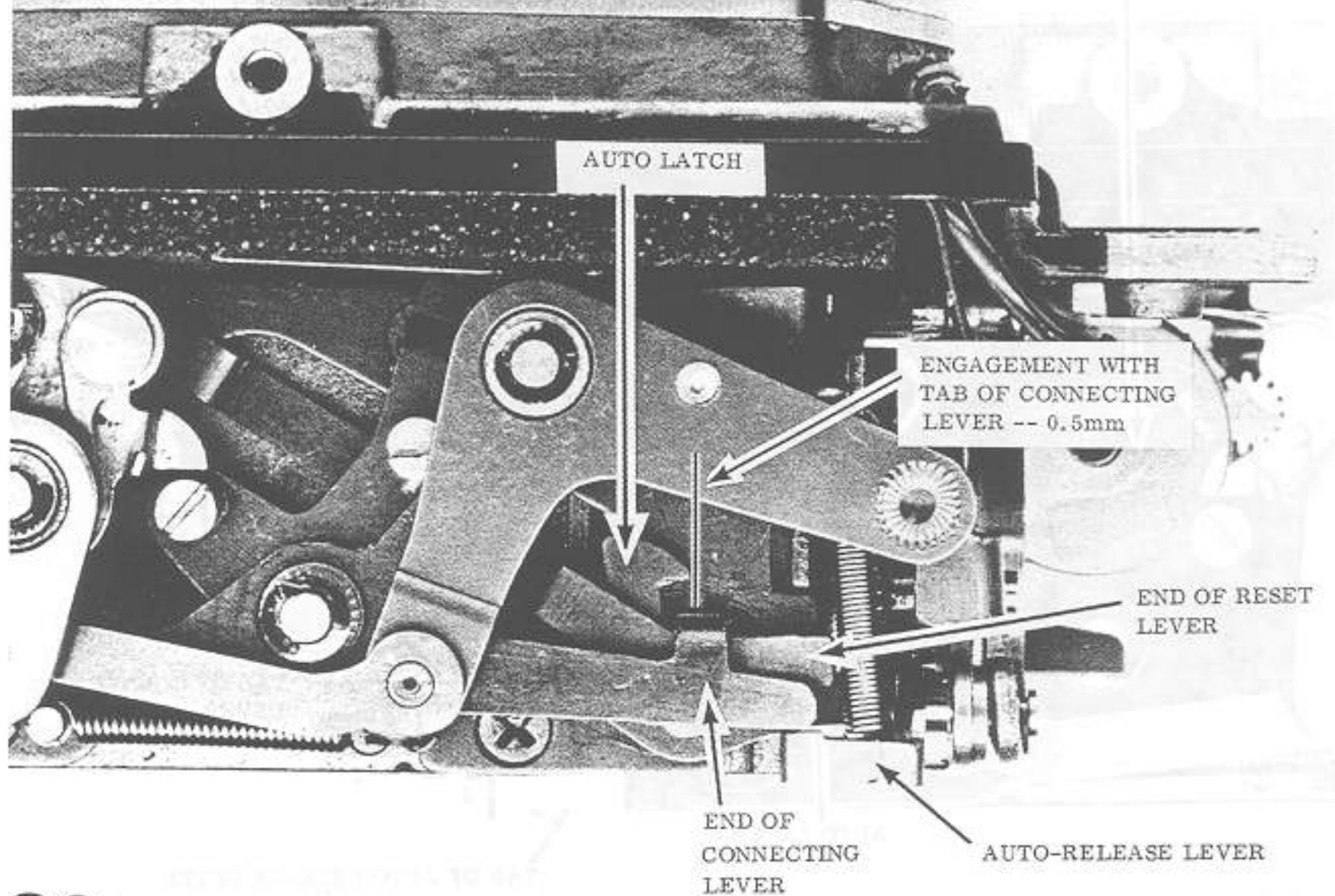

80

DIAPHRAGM-SETTING RING AT AUTOMATIC SETTING

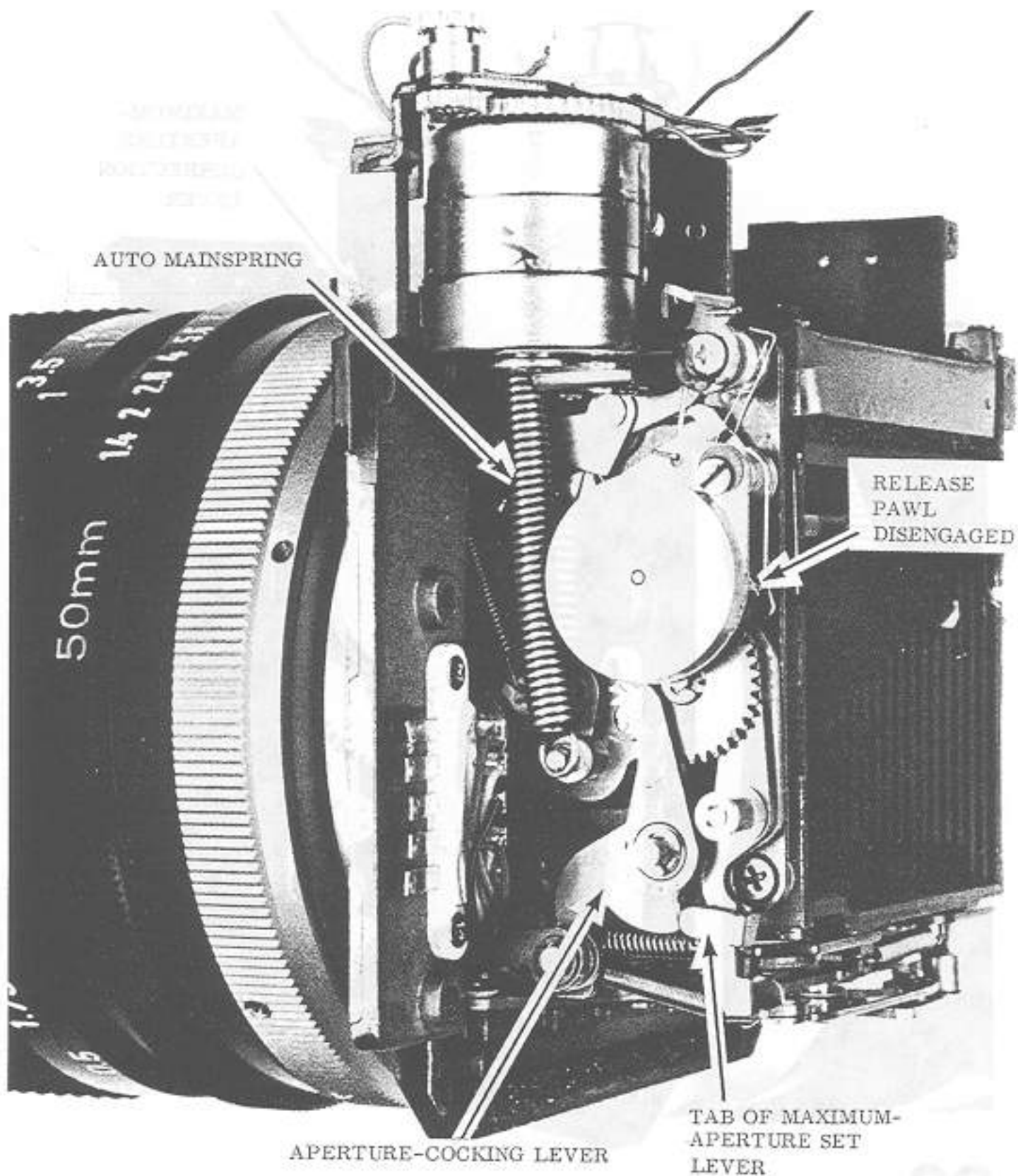

81

AUTO DIAPHRAGM-CONTROL UNIT RELEASED

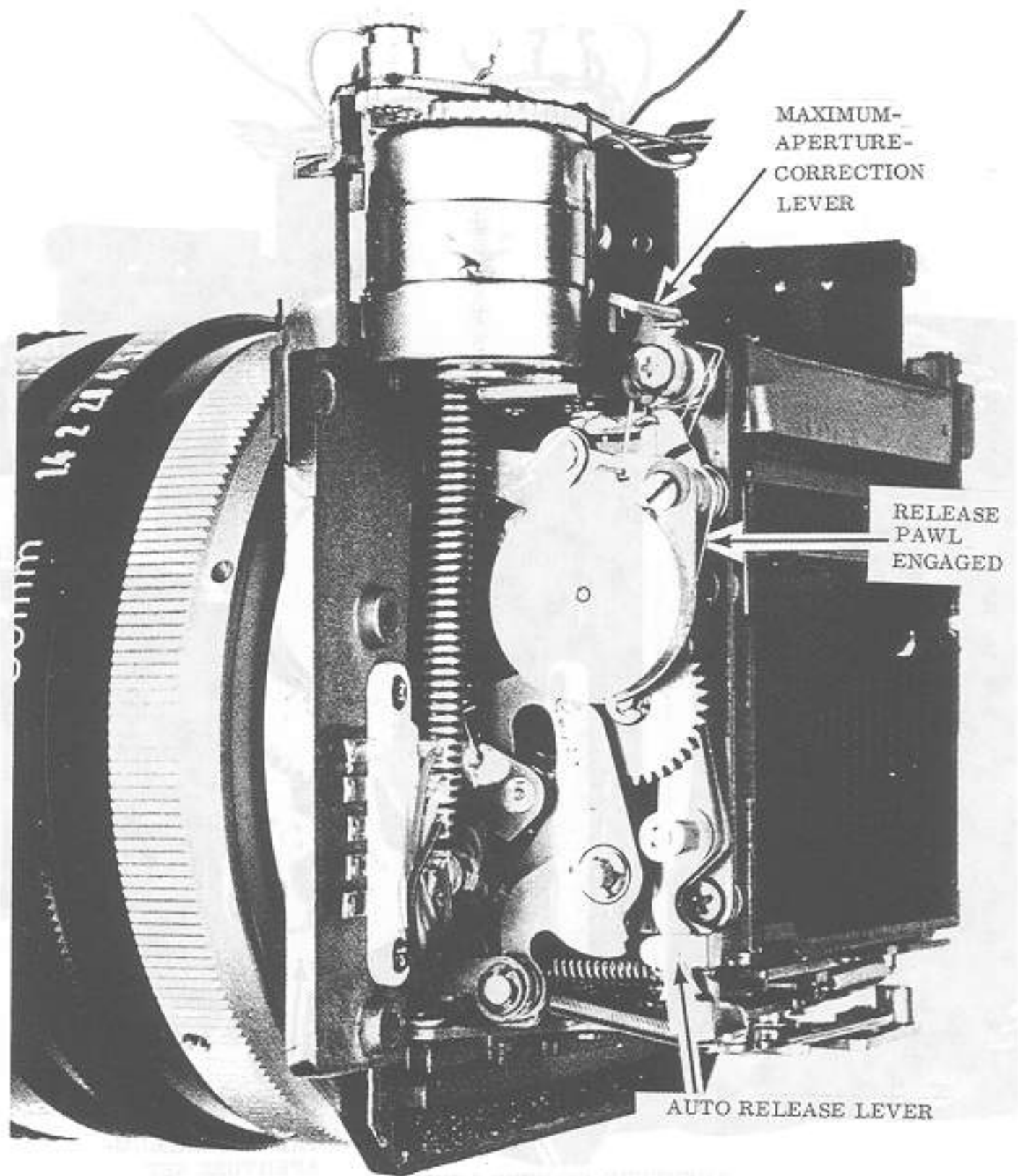

82

AUTO DIAPHRAGM-CONTROL UNIT TENSIONED

18

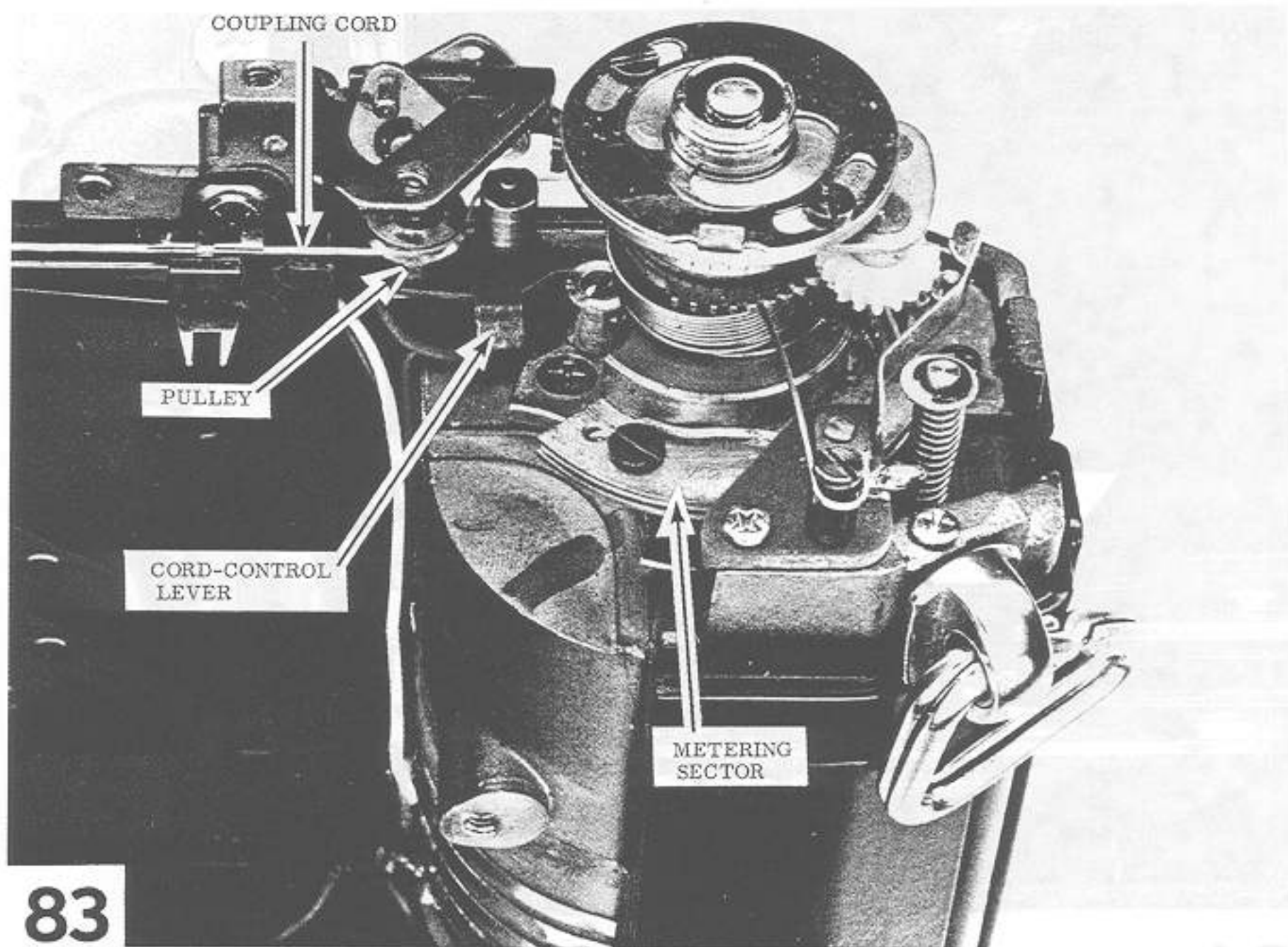

83

84

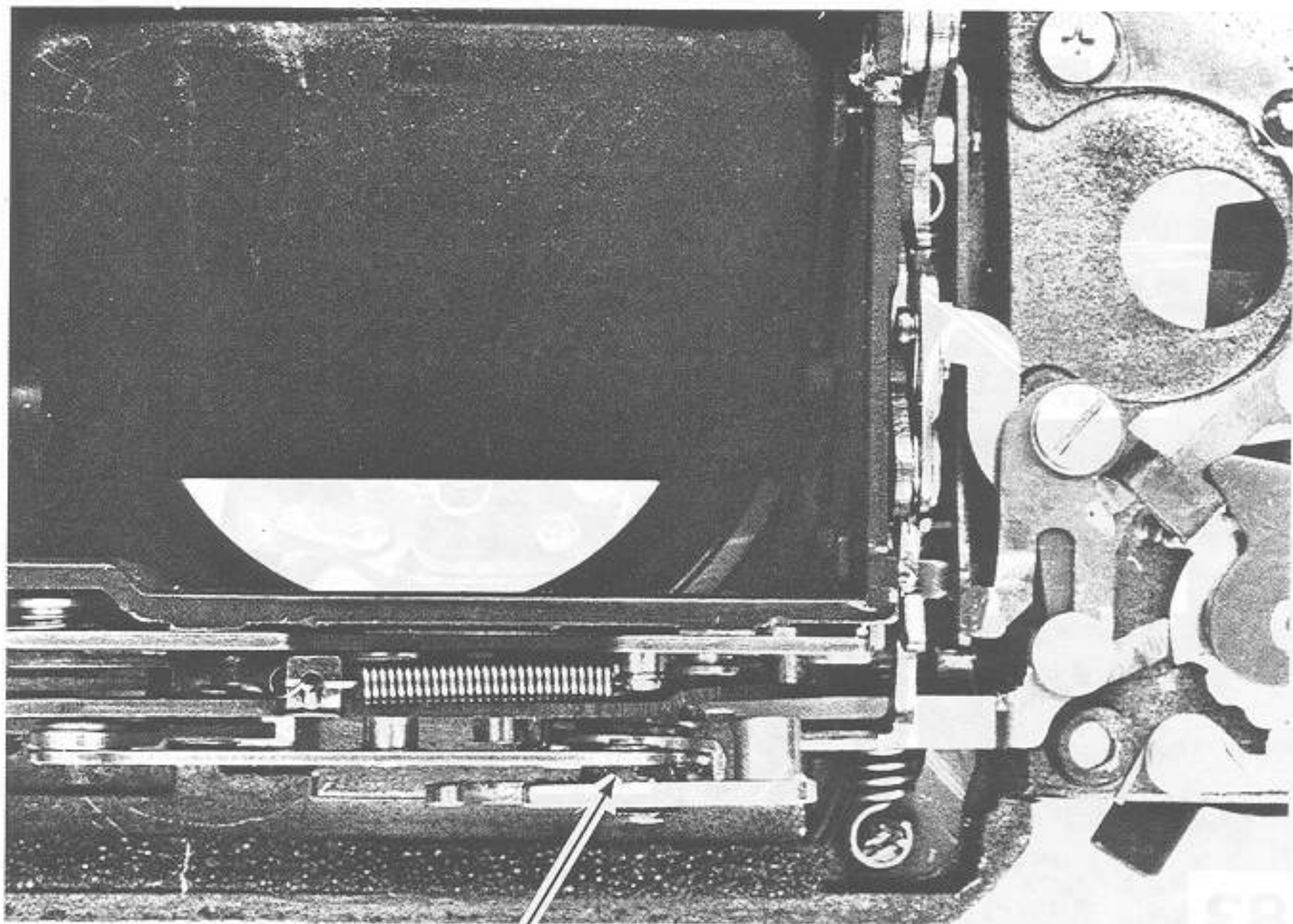

84

ECCENTRIC BETWEEN MIRROR-COCKING LEVER AND AUTO LINK -- ADJUST UNTIL THE RELEASE PAWL AND THE MIRROR-RELEASE LEVER ENGAGE SIMULTANEOUSLY

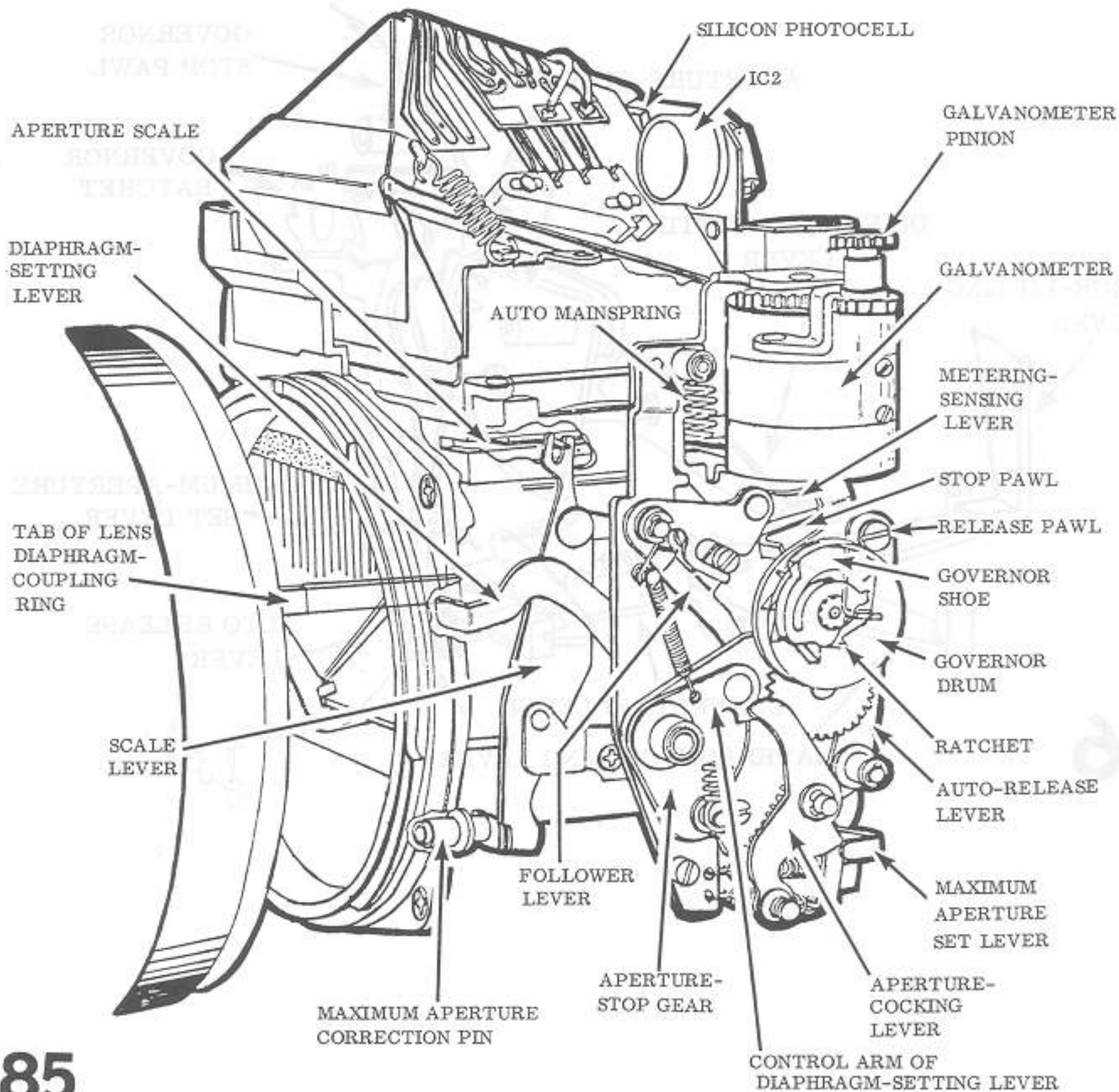

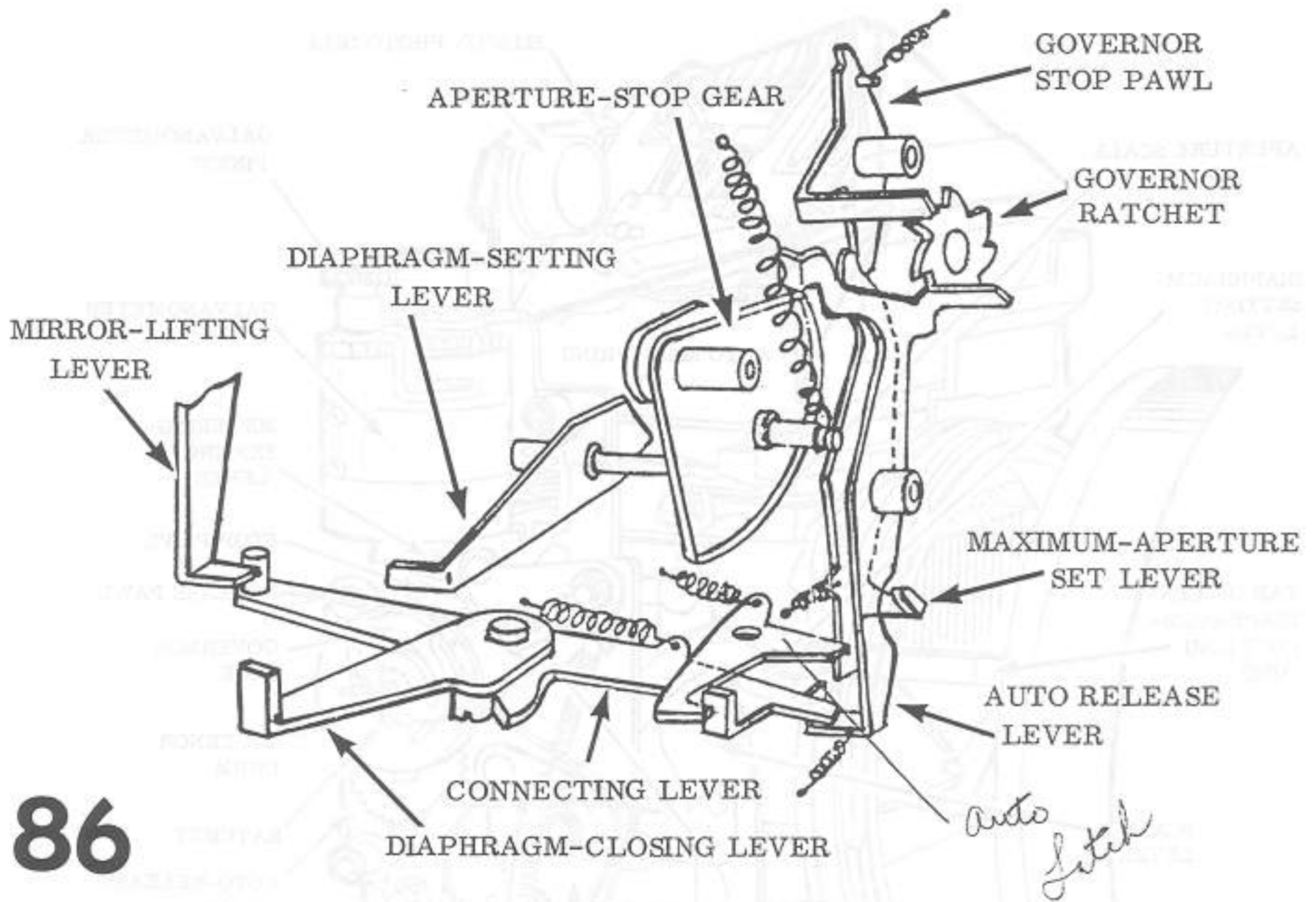

86

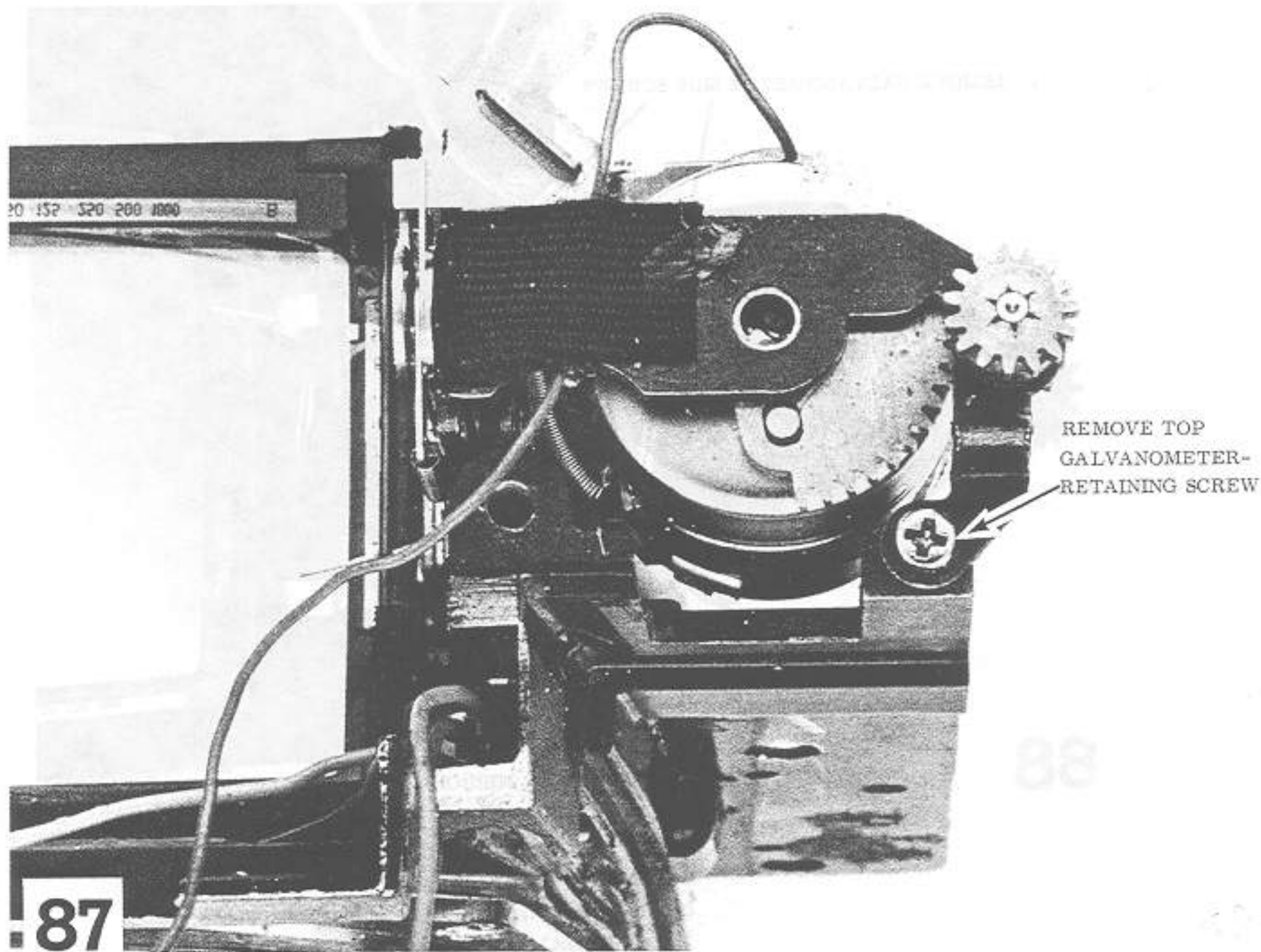

20 152 320 200 1000 B

REMOVE TOP  
GALVANOMETER-  
RETAINING SCREW

88

87

1. REMOVE GALVANOMETER SIDE SCREWS

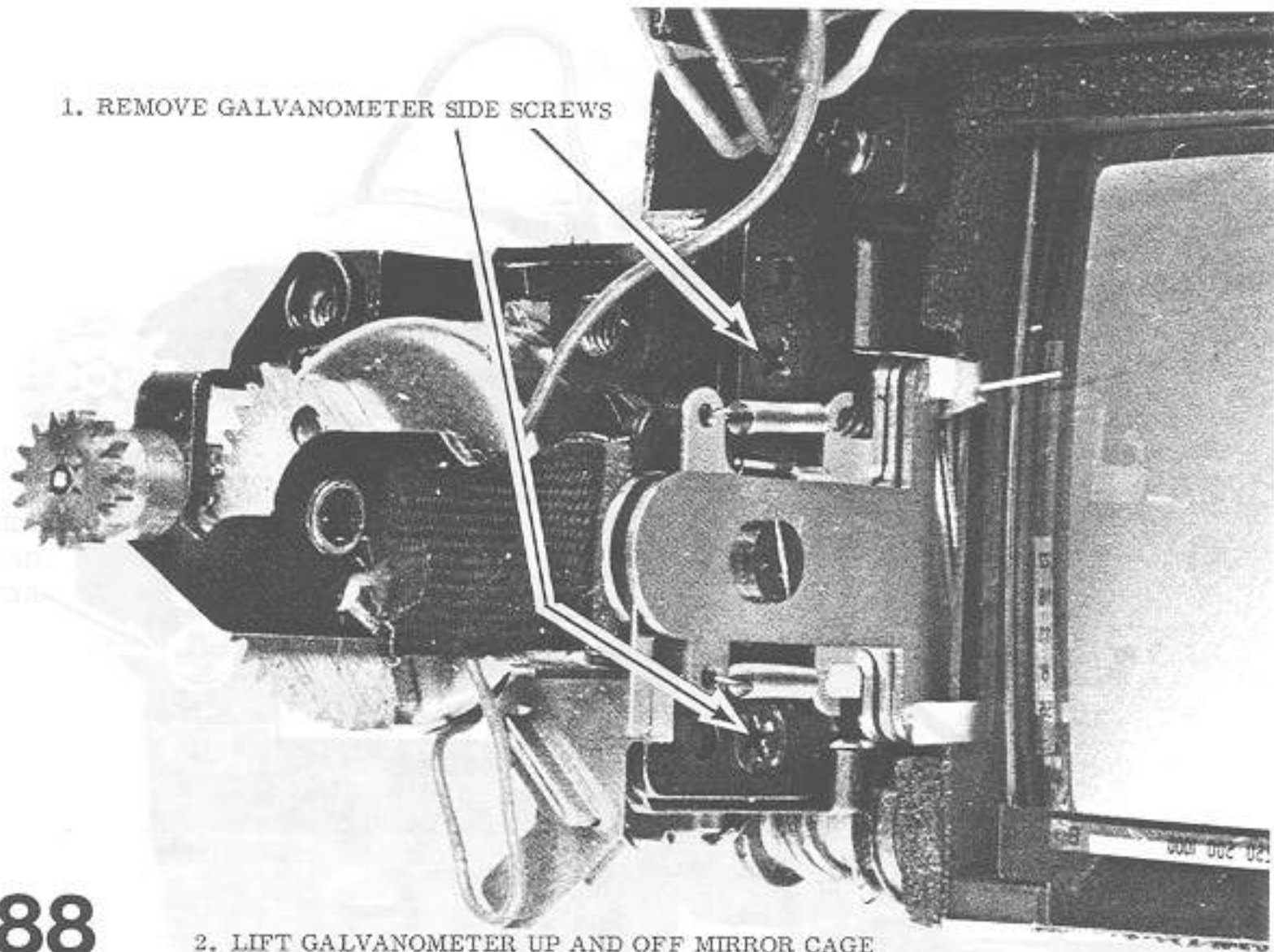

2. LIFT GALVANOMETER UP AND OFF MIRROR CAGE

88

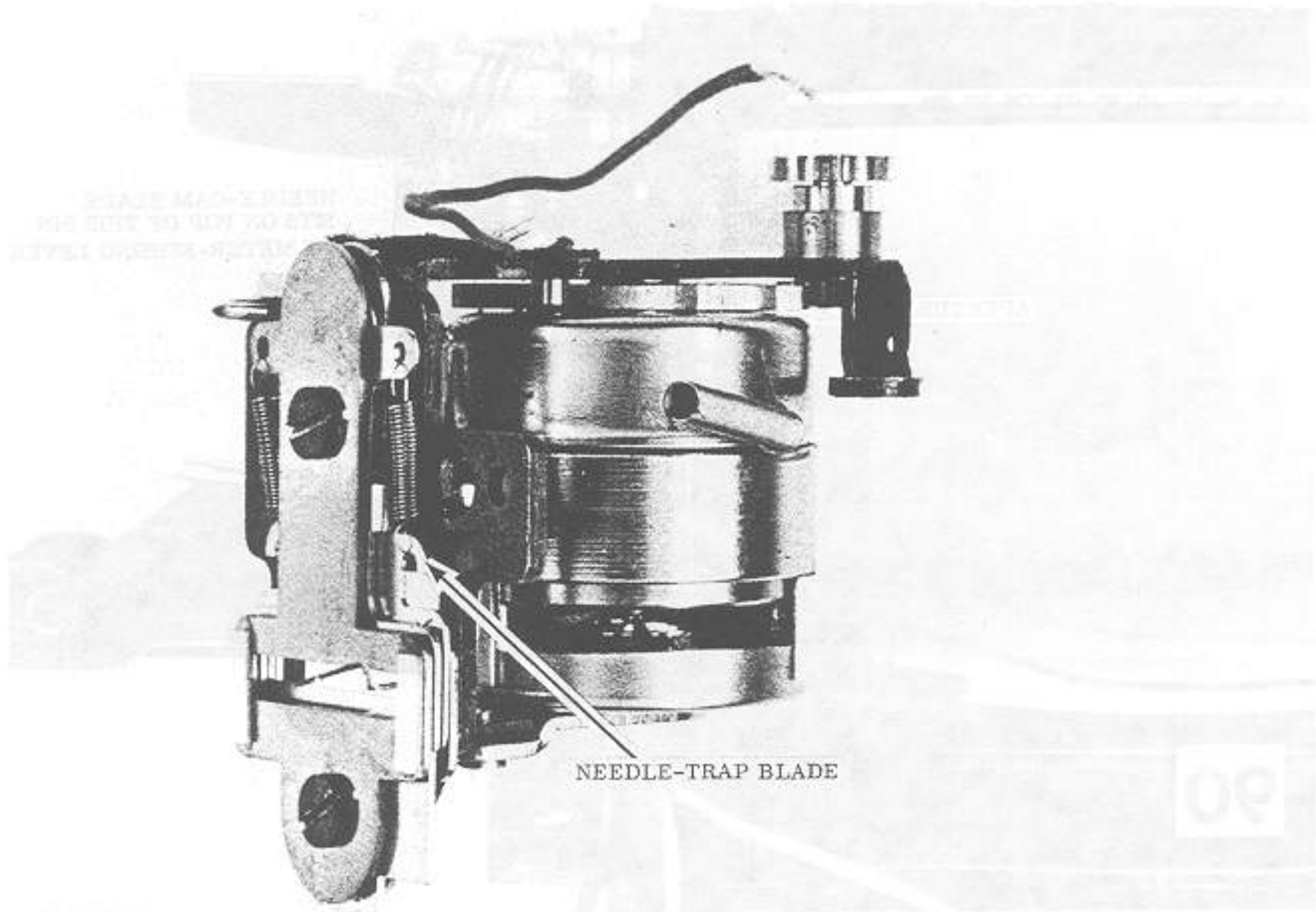

NEEDLE-TRAP BLADE

NEEDLE-CAM BLADE

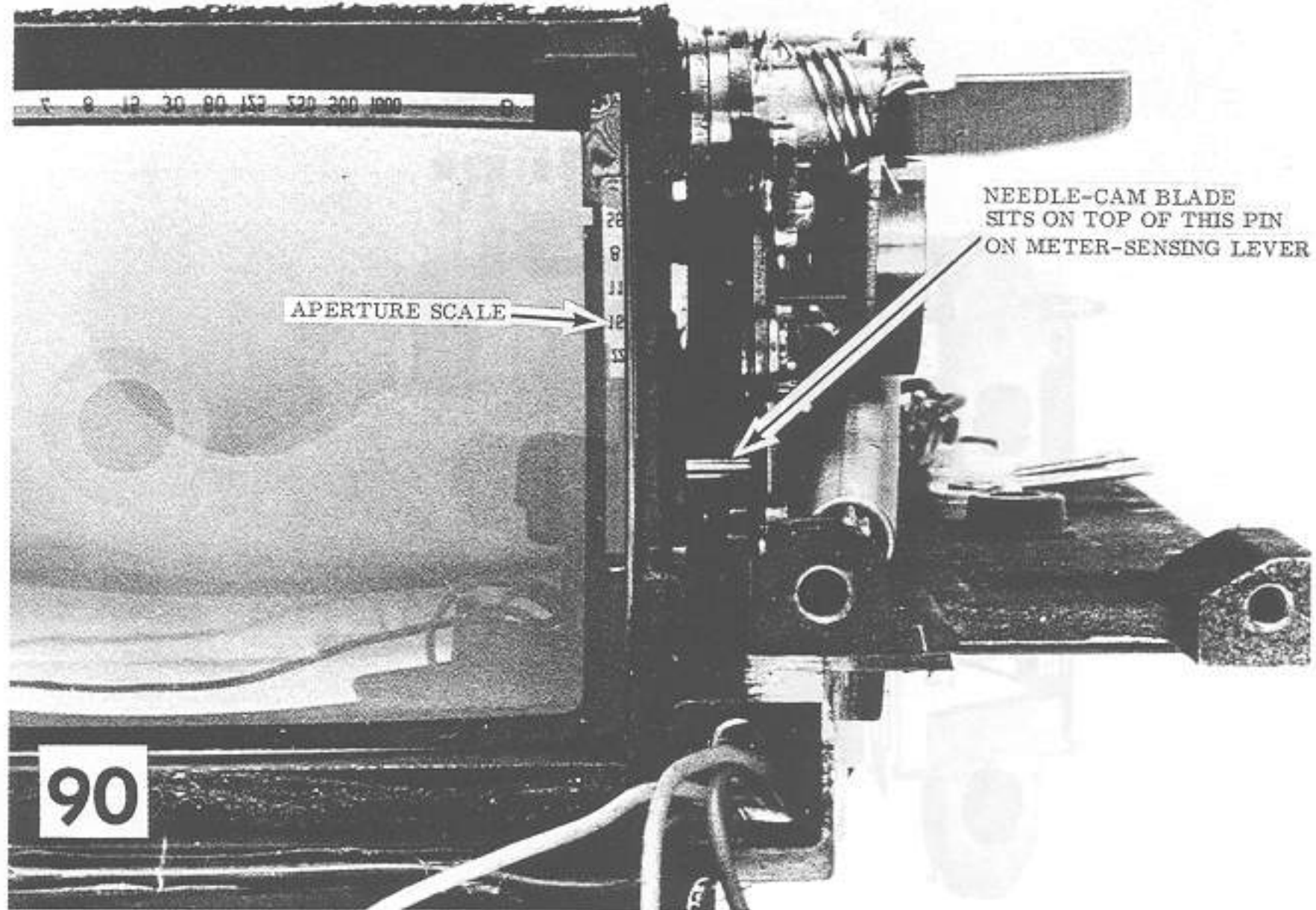

APERTURE SCALE

NEEDLE-CAM BLADE  
SITS ON TOP OF THIS PIN  
ON METER-SENSING LEVER

90

98

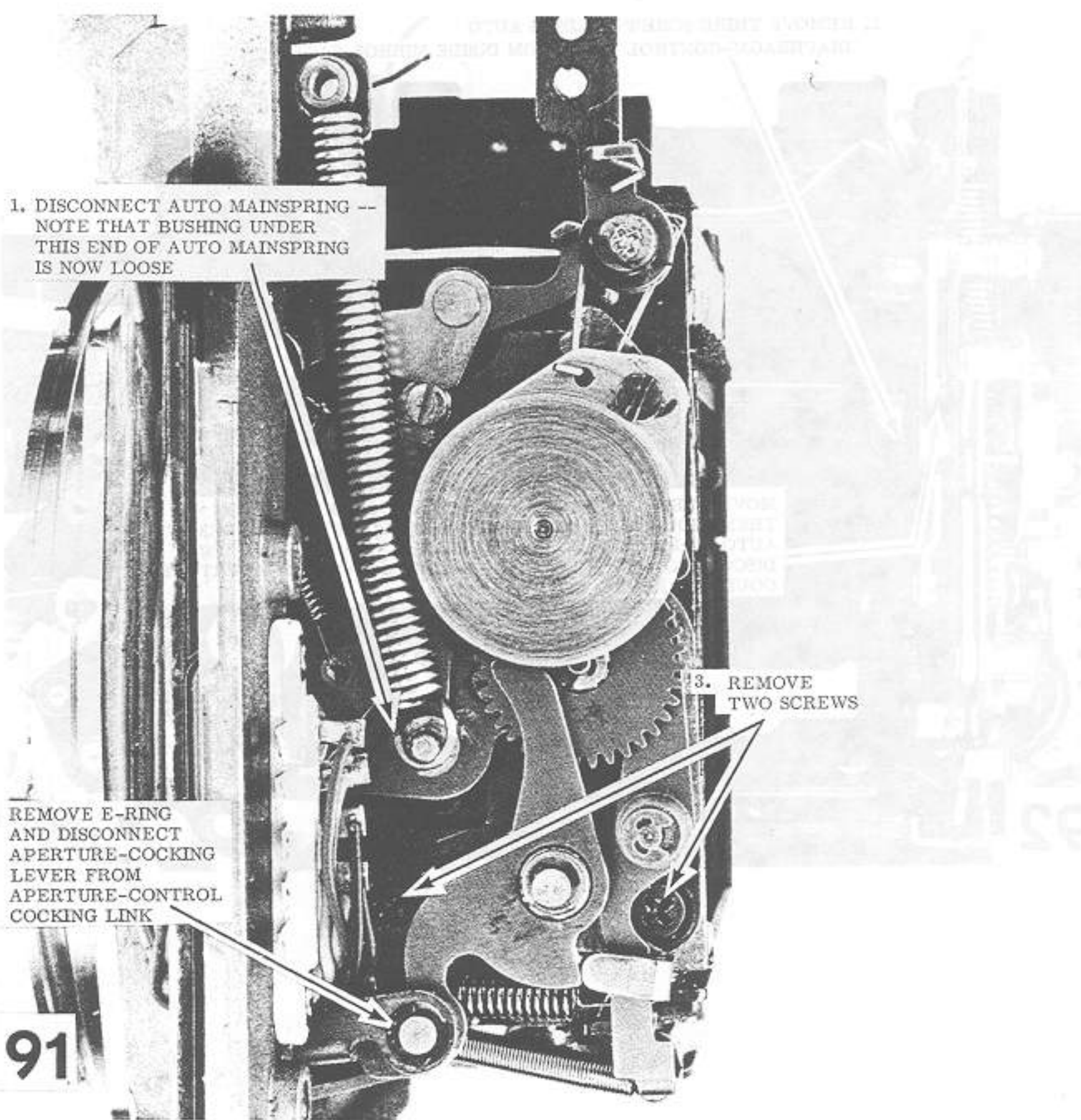

1. DISCONNECT AUTO MAINSPRING --  
NOTE THAT BUSHING UNDER  
THIS END OF AUTO MAINSPRING  
IS NOW LOOSE

2. REMOVE E-RING  
AND DISCONNECT  
APERTURE-COCKING  
LEVER FROM  
APERTURE-CONTROL  
COCKING LINK

3. REMOVE  
TWO SCREWS

1. REMOVE THIRD SCREW HOLDING AUTO  
DIAPHRAGM-CONTROL UNIT FROM INSIDE MIRROR CAGE

MOVE APERTURE-STOP GEAR TO THE COCKED POSITION --  
THEN, HOLD DOWN DIAPHRAGM-SETTING LEVER AND REMOVE  
AUTO DIAPHRAGM-CONTROL UNIT -- AS YOU REMOVE UNIT,  
DISCONNECT SCALE-LEVER LINK FROM MAXIMUM-APERTURE  
COUPLING LEVER

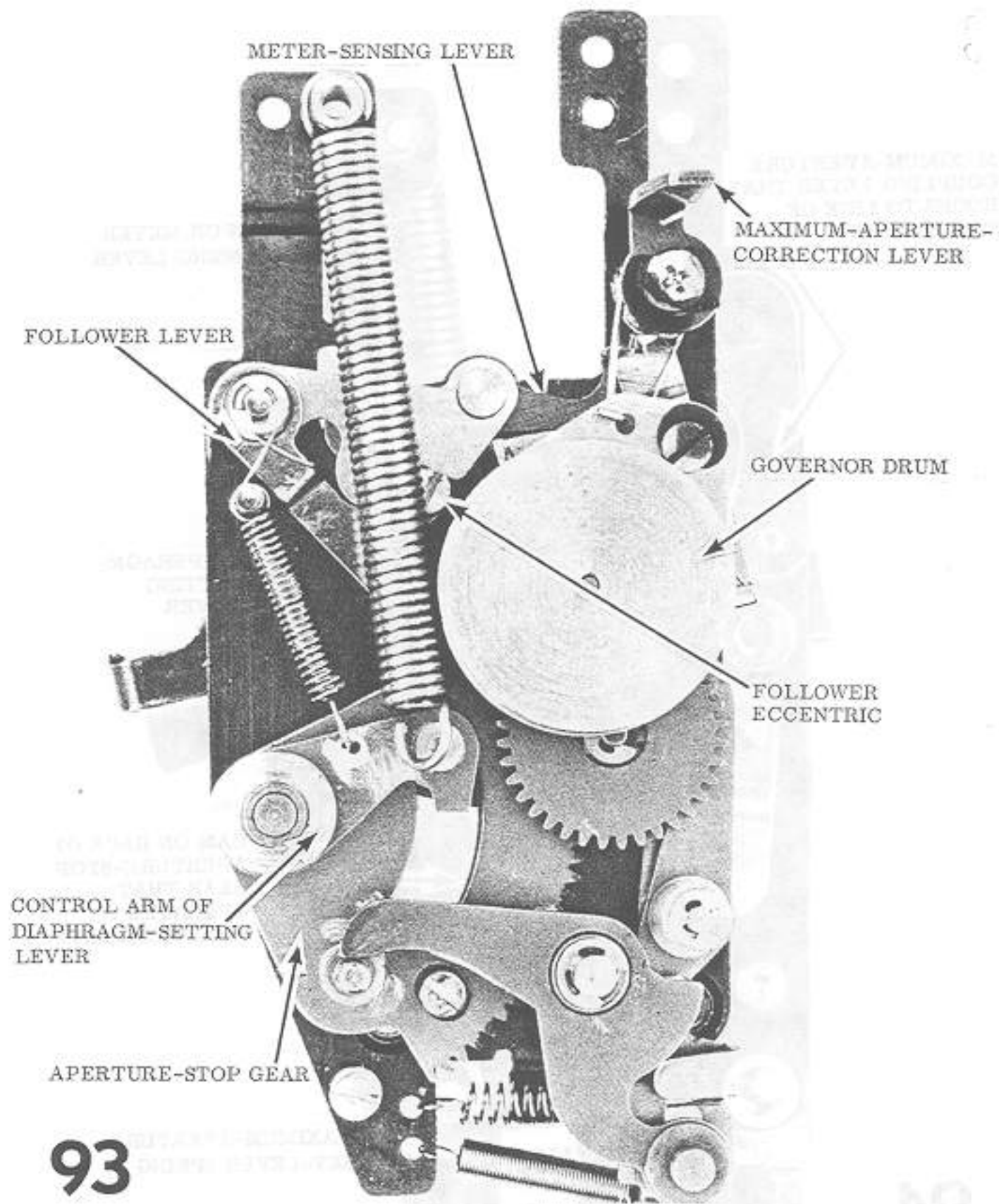

*Clear the Assembly*

MAXIMUM-APERTURE  
COUPLING LEVER THAT  
HOOKS TO LINK OF  
SCALE LEVER

PIN ON METER-  
SENSING LEVER

DIAPHRAGM-  
SETTING  
LEVER

CAM ON BACK OF  
APERTURE-STOP  
GEAR THAT  
OPERATES  
FOLLOWER LEVER

MAXIMUM-APERTURE-  
SET-LEVER SPRING

AUTO-RELEASE-LEVER SPRING

94

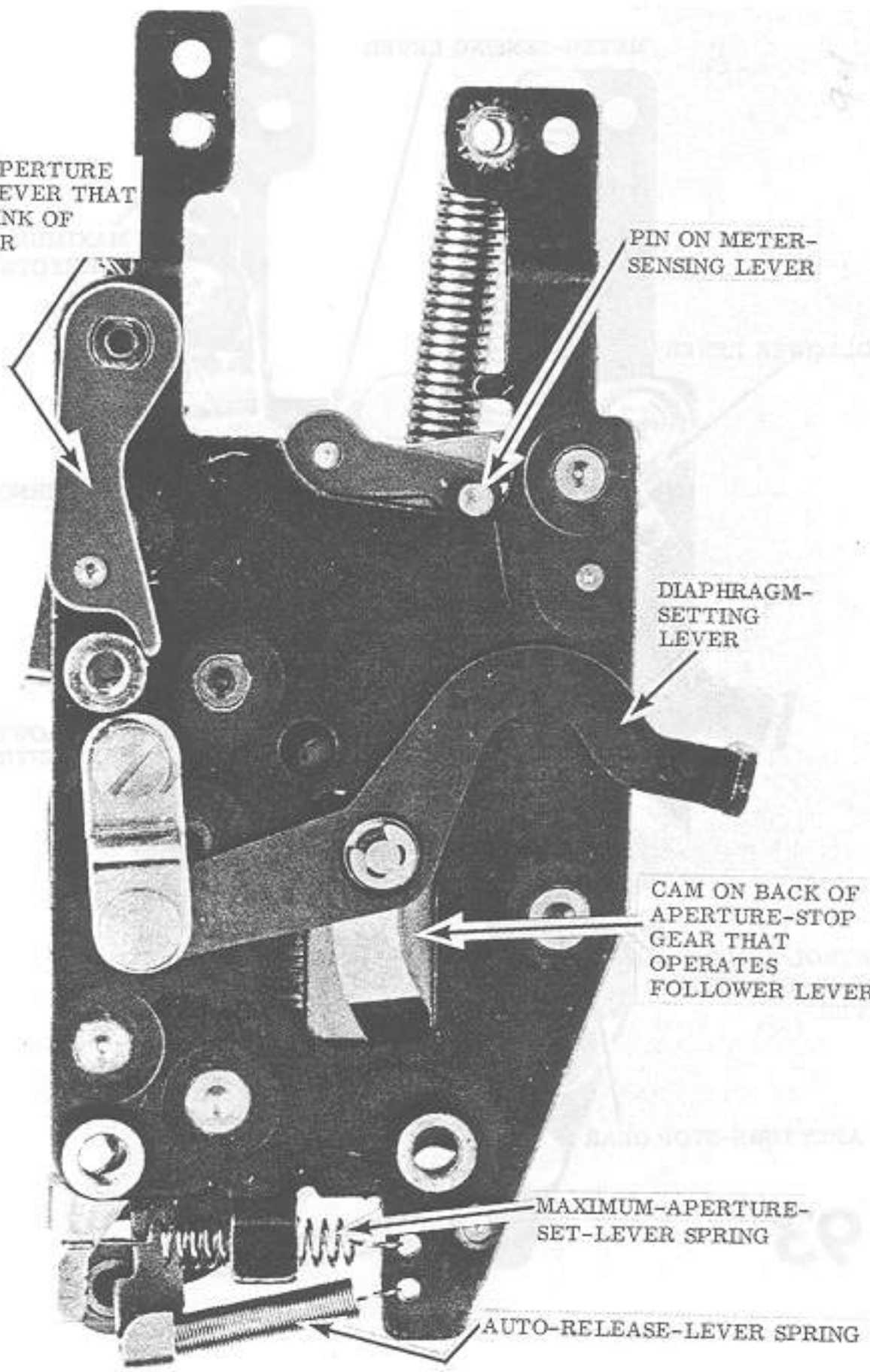

SCALE LEVER COUPLES TO  
APERTURE SCALE HERE

SCALE-LEVER LINK

SCALE LEVER

→ Scribe  
bracket before  
removing

1. REMOVE TWO SCREWS AND FILM-SPEED COUPLER

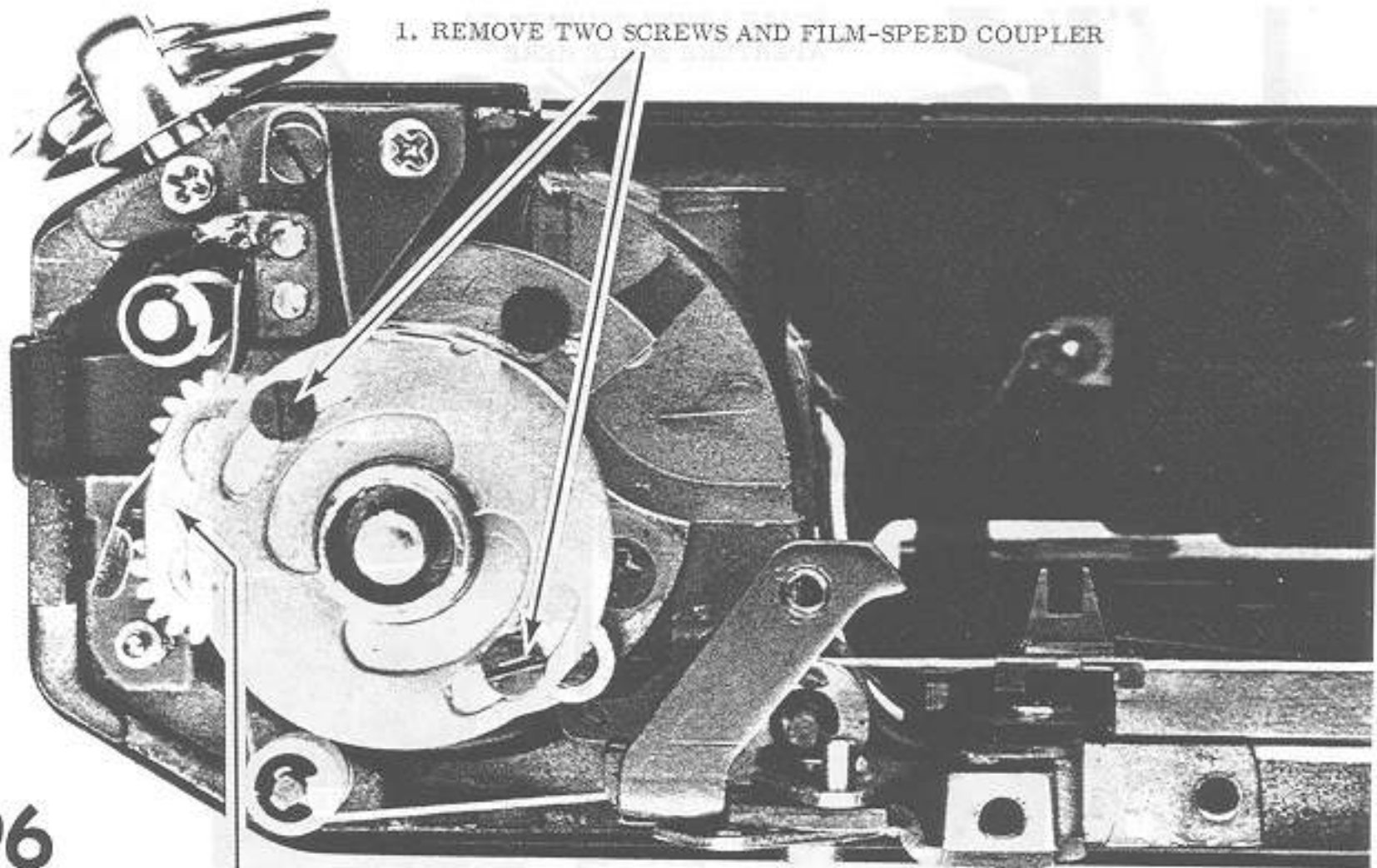

96

2. LIFT OFF FILM-SPEED GEAR UNIT  
(SPACER UNDERNEATH)

1. DISCONNECT SPRING OF METERING SECTOR

METERING  
SECTOR

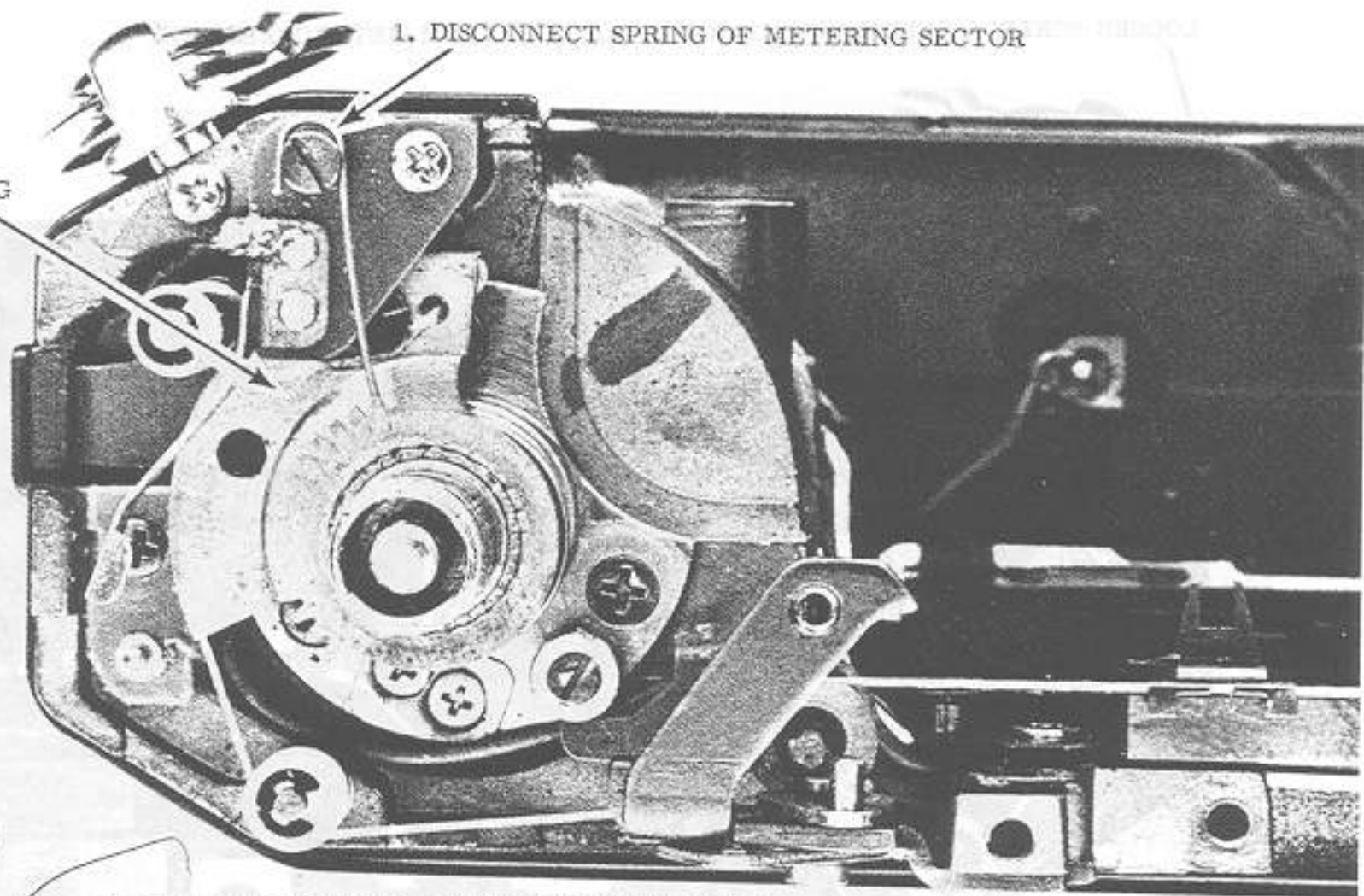

97

NOTE: ON REASSEMBLY, APPLY ONE FULL TURN  
OF TENSION TO THE METERING-SECTOR SPRING

89

LOOSEN SCREW AND DISCONNECT COUPLING CORD FROM METERING SECTOR

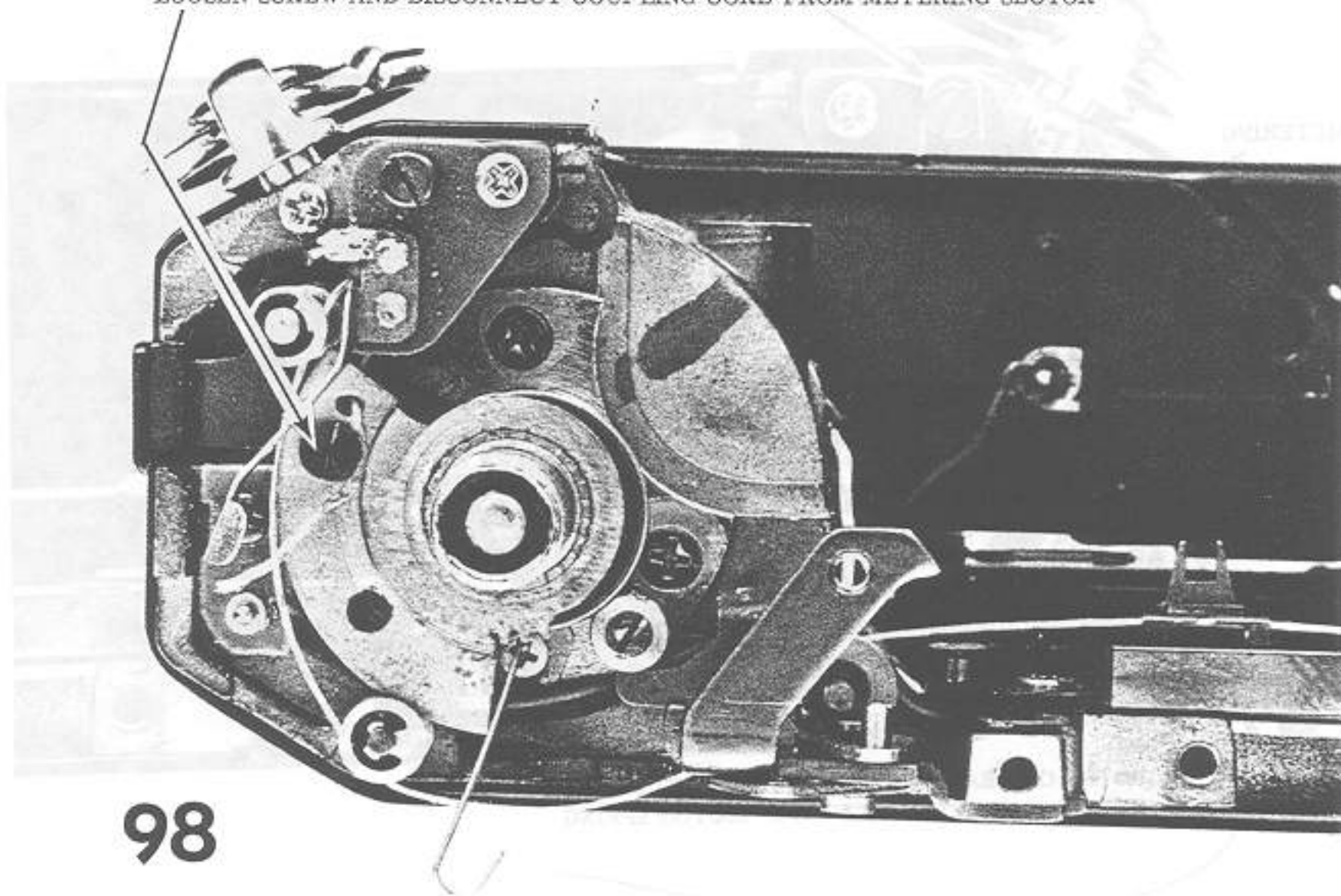

98